

# PRO 2 PB

## COMPACT PIPE BEVELLER

### Overview

PRO 2 PB is a compact, handy pipe beveler that mills pipes made of carbon and stainless steel, aluminum alloys, and copper-nickels. The machine can face and bevel pipes from inner diameters (ID) of 22 mm to outer diameters (OD) of 48 mm.

Small pipes from ID 15.5 mm up to OD 30 mm can be beveled with optional small mandrel set. PRO 2 PB is able to mill also larger pipes from ID 42 mm up to OD 60.3 mm by means of an optional extension set.

Its exceptionally narrow housing (only 48 mm wide) makes it perfectly suited to space restricted areas such as boiler water walls.

PRO-2 PB incorporates overload systems incl. wet multi-disk friction clutch to prevent gear damage if the tool gets stuck.



### 3 different sources of power to choose from:



Max wall thickness up to 8mm.

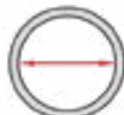

ID 22mm - 42mm  
ID 15.5mm - 22mm (optional)  
ID 42mm - 58mm (optional)



Facing off



OD beveling up to 48mm  
OD beveling up to 60.3mm (optional)

TECHNICAL SPECIFICATIONS	PRO 2 PB with air motor	PRO 2 PB with electric motor	PRO 2 PB with battery motor
Motor	Pneumatic Motor Air Requirement: 0.6 MPa (87 psi) Air Consumption: 1400 l/min (50 CFM) Power: 800 W Part# WAP-B05/100	Electric Motor Voltage: 1~ 220 - 240 V, 50 - 60 Hz Power: 1100 W Part# WAP-B02/105	Battery Powered Motor Voltage: 18 V DC, 5.2 Ah Part# WAP-B02/108
Connection	CEJN 410 DN 10.4 R 1/2" BSPT fitting for quick-coupling	Electrical plug	Battery connection
Rotational speed without load	210 rpm	10 - 134 rpm (gear 1) 30 - 377 rpm (gear 2)	10 - 60 rpm (gear 1) 30 - 205 rpm (gear 2)
Rotational speed (nominal)	105 rpm	10 - 134 rpm (gear 1) 30 - 377 rpm (gear 2)	10 - 60 rpm (gear 1) 30 - 205 rpm (gear 2)
Pipe diameter	22mm ID - 48mm OD 15.5mm ID - 30mm OD* 42mm ID - 60.3mm OD**	22mm ID - 48mm OD 15.5mm ID - 30mm OD* 42mm ID - 60.3mm OD**	22mm ID - 48mm OD 15.5mm ID - 30mm OD* 42mm ID - 60.3mm OD**
Maximum pipe wall thickness	8mm 3.5mm	8mm 3.5mm	8mm 3.5mm
Weight with motor	7.6kg	7.4kg	6.5kg including battery

\* With an optional small mandrel set (WAP-B02/150)

\*\* With an optional extension set (WAP-B02/130)

## Package Includes

- PRO 2 PB Beveling Machine (Not Including Motor Or Cutting Inserts)
- Standard Self-Centering Expandable Mandrel For Pipe Id  $\varnothing$  18 – 42 Mm (0.70 – 1.65")
- 2 Sets Of Jaws (No. 4, 5),
- 3 Sets Of Jaw Blocks (No. 6, 7, 8)
- 5 Sets Of Springs (No. 4, 5, 6, 7, 8) For Standard Mandrel
- Tool Bit Holder
- Spring Gauge
- Handle
- Coolant Container With Nozzle
- Set Of Tools
- Operator'S Manual
- In Metal Carry Case

## Dimensions

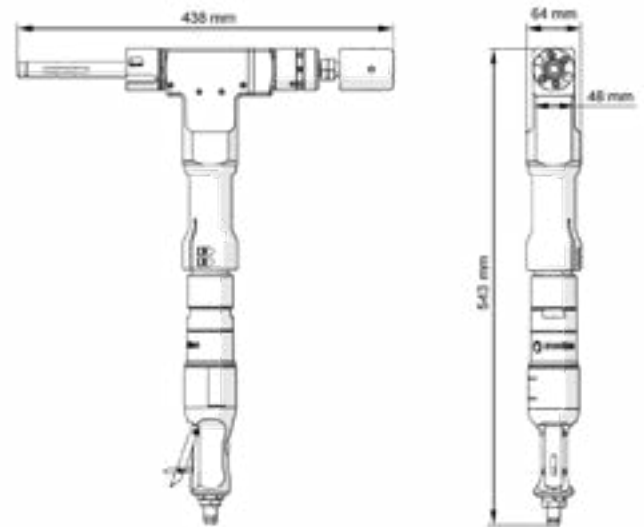

PRO 2 PB with pneumatic motor

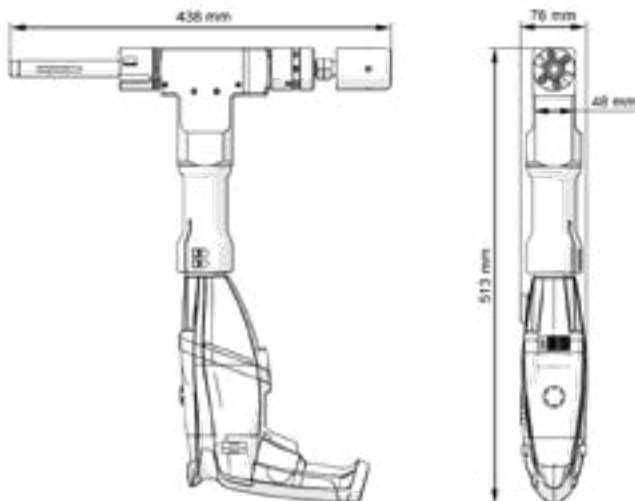

PRO 2 PB with electric motor



PRO 2 PB with battery motor

## Optional Accessories

Pneumatic motor  
Part# WAP-B05/100



Adapter and driver  
for pneumatic motor  
Part# WAP-B02/110



Electric Motor  
Part# WAP-B05/105



Driver for electric motor  
Part# WAP-B02/112



Battery motor  
& two 5.2 Ah batteries  
Part# WAP-B02/108



Driver for battery motor  
Part# WAP-B02/114



5.2 Ah battery  
Part# AKM-000088



Battery charger  
Part# LDV-000011



## Tool bits:

<b>WAP-B02/F040</b> for steel	0 degree facing tool bit short	
<b>WAP-B02/F040T</b> for stainless steel	0 degree facing tool bit short*	
<b>WAP-B02/F052</b> for steel	0 degree facing tool bit long	
<b>WAP-B02/F052T</b> for stainless steel	0 degree facing tool bit long*	
<b>WAP-B02/B3050</b> for steel	30 degree bevelling tool bit	
<b>WAP-B02/B3050T</b> for stainless steel	30 degree bevelling tool bit*	
<b>WAP-B02/B37553</b> for steel	37.5 degree bevelling tool bit	
<b>WAP-B02/B37553T</b> for stainless steel	37.5 degree bevelling tool bit*	
<b>WAP-B02/B4556</b> for steel	45 degree bevelling tool bit	
<b>WAP-B02/B4556T</b> for stainless steel	45 degree bevelling tool bit*	

Small mandrel set for pipes  
from ID 15.5mm to OD 30mm  
Part# **WAP-B02/150**



Extension set for pipes  
from ID 42mm to OD 60.3mm  
Part# **WAP-B02/130**

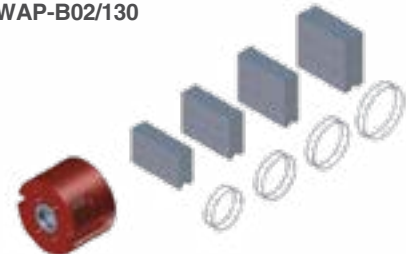

\* Tool bits for stainless steel feature TiAIN coating

