



BROBO GROUP®

A.C.N. 098 264 316
A.B.N. 42 098 264 316

BROBO WALDOWN (AUST) PTY. LTD.

65-67 Williams Rd, Dandenong, 3175
PO BOX 4274 Dandenong Sth, 3164
Victoria, AUSTRALIA.

Tel: 61 3 9794 8751
Fax: 61 3 9794 8792

Email: info@brobo.com.au
Website: www.brobo.com.au



Quality
ISO 9001

PRODUCT AND MAINTENANCE MANUAL

AUTOMATIC CUTTING SAW

Model No. TNF-125

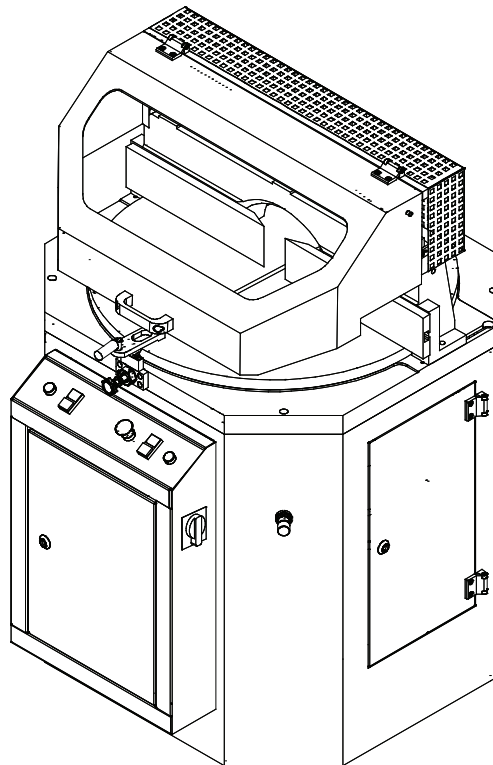

YOUR BROBO WALDOWN DISTRIBUTOR IS:

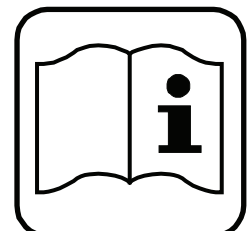

INDEX

1.	INTRODUCTION	2
2.	SAFETY APPLICATIONS.....	3
2.1	DESCRIPTION OF THE SYMBOLS USED IN THE INSTRUCTION	3
2.2	SAFETY INSTRUCTIONS	4
3.	PRODUCT DESCRIPTION	6
3.1	GENERAL VIEW	6
3.2	TECHNICAL DESCRIPTION	7
3.3	TECHNICAL FEATURES	7
3.4	CUTTING DIAGRAMM.....	7
4.	INSTALLATION	8
4.1	TRANSPORTATION INSTRUCTIONS.....	8
4.2	REQUIRED WORKING AREA.....	8
4.3	INSTALLATION SETTINGS.....	9
4.4	FIRST CONNECTION	10
5.	PRINCIPLES OF WORK.....	11
5.1	MAIN SETTINGS	11
5.1.1	MEASURE CALIBRATION	11
5.2	CONTROL ELEMENTS	11
5.3	OPERATION OF MACHINE	12
6.	MAINTENANCE AND THE LUBRICATION OF THE MACHINE	13
6.1	MAINTENANCE TABLE	13
6.2	MAGNETIC SENSOR	14
6.3	CHANGING THE BLADE	14
7.	PNEUMATIC ELEMENTS.....	15
7.1	VALVE AND CYLINDER CONTROL.....	15
7.2	CYLINDER SPEED ADJUSTMENT.....	16
7.3	HYDRAULIC SPEED CONTROL CYLINDER.....	17
7.4	COOLING SYSTEM.....	18
7.5	FILTER-REGULATOR	19
7.5.1	RECOMMENDED FILTER-REGULATOR OILS	20
8.	TROUBLESHOOTING	21
8.1	ACTIONS TO BE TAKEN DURING FAILURE.....	21
8.2	FAILURE – REASON – SOLUTION TABLE.....	21
9.	CIRCUIT DIAGRAMS	22
9.1	PNEUMATIC CIRCUIT DIAGRAM	22
9.2	ELECTRIC CIRCUIT DIAGRAM	23
10.	WARRANTY	25

1. INTRODUCTION

We congratulate you on acquisition of the high-quality equipment. Undoubtedly, you have made a correct and well-founded choice, production of our company is the highly reliable product corresponding to the European quality standards. The equipment is simple in usage, has high consumer properties and will serve you long.

User instruction contains the manufacturer states principles of work and machine use. Each operator, beginning to work on the machine should familiarise attentively with the instruction and understand it.

At correct operation and observance requests of the present instruction the manufacturer guarantees working capacity of the machine during a warranty period.

MANUFACTURER:



BROBO GROUP

BROBO WALDOWN (AUST) PTY. LTD.

65-67 Williams Rd, Dandenong, 3175
PO BOX 4274 Dandenong Sth, 3164
Victoria, AUSTRALIA.

Tel: 61 3 9794 8751

Fax: 61 3 9794 8792

A.C.N. 098 264 316

A.B.N. 42 098 264 316



Email: info@brobo.com.au

Website: www.brobo.com.au



Probably that some functional features of the machine are not reflected in the given document.



Conformity of the information containing in the given document is checked by us. Nevertheless some divergences are possible and complete conformity of the validity is not guaranteed.















The manufacturer reserves the right on production and instruction change.

2. SAFETY APPLICATIONS





















1. It is forbidden to use machine to any person, except the operator.
2. Start operation only at complete reliance that you have familiarized and have understood with designations and the definitions, concerning safety.
3. It is forbidden to work and execute operations on the machine for operator who has not familiarized with the given instruction,
4. Acquaintance and understanding of the given instruction has importance for prevention of aggrieving to the operator, third persons, animal, to environment and the machine.







DO NOT MAINTAIN THE MACHINE WITHOUT OBSERVANCE OF THE ABOVE-STATED ITEMS AS SUCH OPERATION OF THE MACHINE IS UNEQUIVOCALLY DANGEROUS!

2.1 DESCRIPTION OF THE SYMBOLS USED IN THE INSTRUCTION

	Instructions on the data given for the purpose of acquaintance with the machine.
	Instructions on necessity of familiarity with a management before machine tool operation.
	Instructions on safety conditions which are obligatory for observance by the user for the purpose of the prevention of drawing of a possible damage to the machine.
	Warning of high voltage presence.
	Warning of possible harm to health of the person and of any kinds of time damage.
	Warning of possibility of occurrence of failures with a deadly or traumatic outcome.
	Instructions for work in protective clothes.
	Instructions on necessity of use of ear-phones at work on the machine.
	Instructions on necessity of use of goggles at work on the machine.
	Instructions on necessity of use of gloves at work on the machine tool.
	Warning about possible trauma receptions at hands clamping.
	Prohibiting sign. It is forbidden to touch. Dangerous.
	Warning of performance of necessary measures before the beginning of service of the equipment.
	Warning of heat presence.
	Attention! Danger of a clamp!

2.2 SAFETY INSTRUCTIONS

	ATTENTION! Read the instruction and familiarize with all rules and positions.
	Keep the instruction in a reliable place. The instruction should be near at hand, for consultations in an operating time on care of the equipment.
	The expert performing works on installation of the machine tool, is obliged to study the given instruction attentively.
	It is forbidden to carry out repair at occurrence of failure of the machine for operator, failure should be eliminated by the expert of service department.
	The machine and its details are necessary for protecting from every possible external influences. Carry out the regular control of filter-regulator and fill up oil level at its insufficiency.
	It is forbidden to be under the machine during loading and unloading.
	It is necessary to provide machine grounding. It is forbidden to maintain the machine tool without grounding!
	At work on the machine it is necessary to use goggles.
	Not to be treated to action of natural noise of the machine it is necessary to use ear-phones.
	At replacement of disks it is necessary to use gloves.
	It is necessary to use only original spare parts.
	Make thrifty use of the control panel, do not suppose any mechanical damages.
	Equipment start is carried out by the expert of service department. It is forbidden to suppose any other person to start.
	Equipment repair should be carried out only by experts of the service centre and only with use of the original spare details and parts.
	Use the equipment for other purposes which distinct from are the provided scope can lead to dangerous situations.
	Be always attentive and watch that you do, do not start thoughtlessly work with the machine. Machine operation is forbidden if you have got tired or be under the influence of narcotic substances, alcohol or medicines. The minute carelessness at equipment operation can lead to serious traumas or mutilations.
	Operation of the machine with the damaged network cable is forbidden. It is necessary to immediately replace the damaged cable with the new.
	Use special working clothes. Don't wear spacious subjects of clothes or an ornament. Preserve hair, clothes and gloves from mobile knots and details. Free clothes, ornaments or long hair can be tightened by moving parts of machine.
	Before the repair or service beginning it is necessary to disconnect a supply of electricity and compressed air from the machine.
	It is forbidden to remove the protective details which are on the machine. It is necessary to remember that protective details of the equipment are established for the purpose of safety at work on the machine.

	Avoid clamping hands between the cylinders intended for fixing of a cross-section and moving parts of the equipment.
	Do not open safety covers to a machine blackout.
	Only one operator should work on the machine.
	The machine should pass regular service and adjustment. Do not use the machine tool in faulty condition.
	Do not use the machine tool in wet and damp premises.
	It is forbidden to touch a heating plate of the working machine.
	Attention! Do not stay between moving cutting heads.

3. PRODUCT DESCRIPTION

3.1 GENERAL VIEW

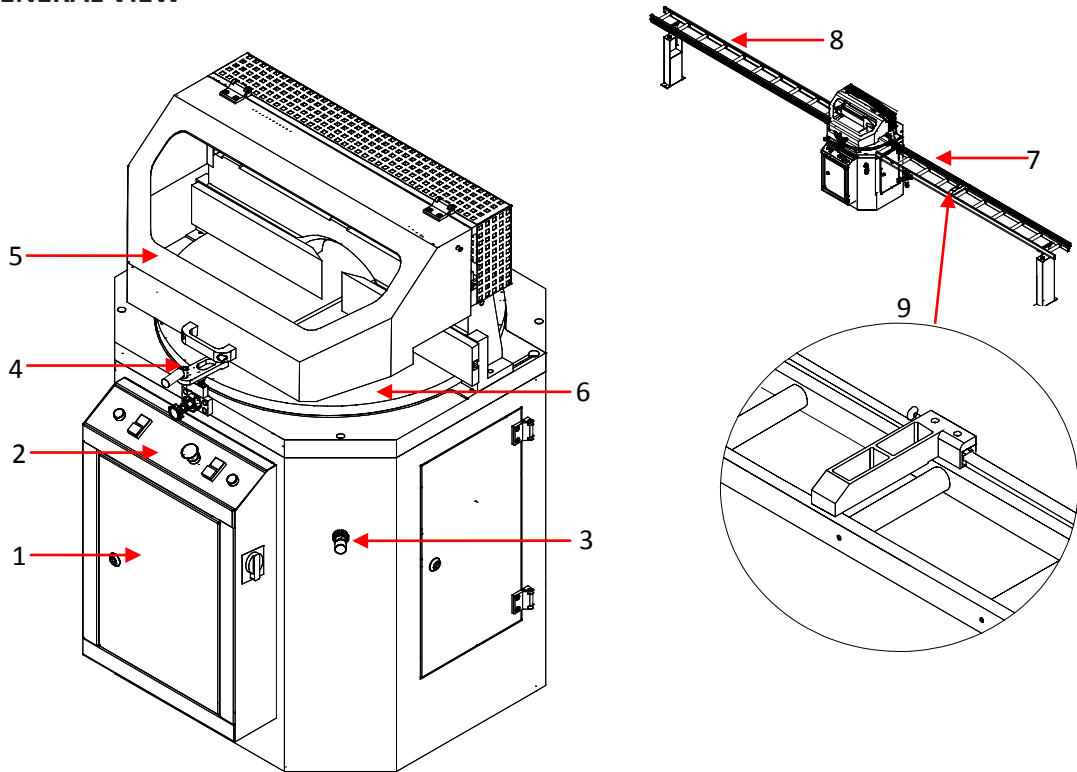

Picture 3.1-1 General view

1. Electrical panel
2. Control panel
3. Output speed regulator
4. Angle degree adjustment handle
5. Safety cover
6. Cutting plate
7. Right conveyor
8. Left conveyor
9. Size adjustment stop

3.2 TECHNICAL DESCRIPTION

- Designed for the cutting of profiles made of aluminium and PVC
- Automatic head position for 0° and 180 °degrees, easy adjustment for intermediate angles
- Vertical pneumatic clamping kit
- Adjustable cutting speed
- The power supply protects system from overvoltage
- Particular care has been taken over the safety measures, both mechanical and electrical
- Bearing and measuring conveyors (3 meters long each)

3.3 TECHNICAL FEATURES

Voltage	: 380 V
Frequency	: 50/60 Hz
Motor power	: 1,5 kW
RPM	: 2810
Total power	: 1,5 kW
Air pressure	: 6–8 Bar
Air consumption	: 41 lt./min.
Sawblade external \varnothing diameter	: 450 mm
Sawblade internal \varnothing diameter	: 30 mm
Sawblade thickness	: 4 mm
Sawblade Z	: 120
Sawblade RPM	: 3200
Minimum cutting length	: 440 mm
Maximum cutting length	: 3300 mm
Cutting angle range	: 45° - 90°
Minimum cutting width	: 148 mm
Width	: 900 mm
Length	: 850 (6900) mm
Height	: 1250 mm
Weight	: 150 kg

3.4 CUTTING DIAGRAMM

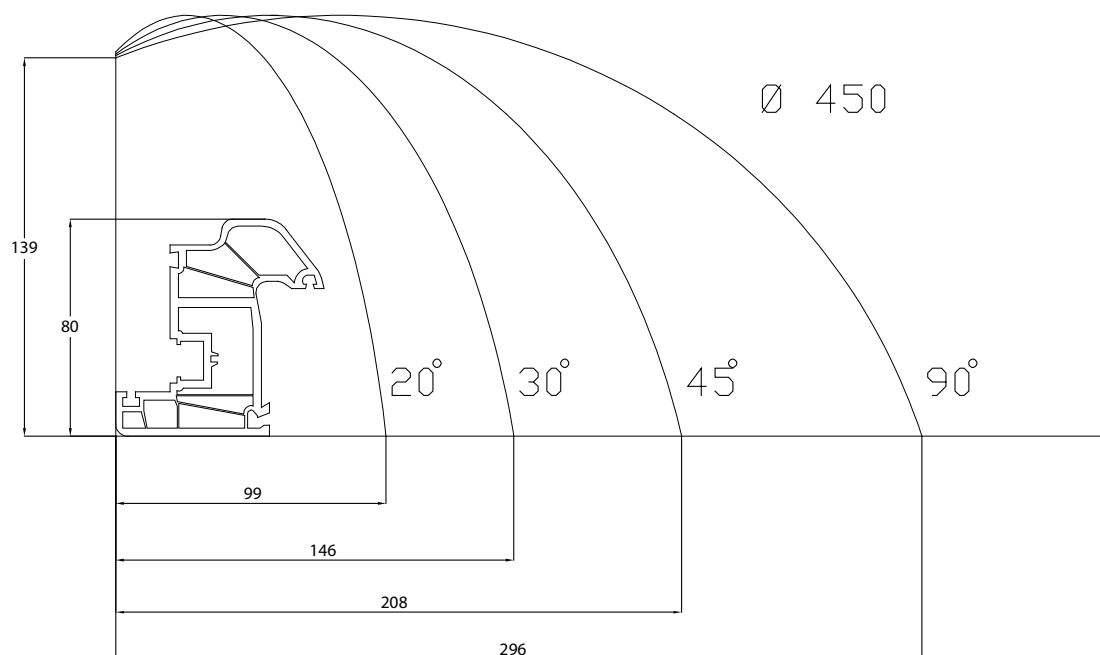

4. INSTALLATION

- ▶ The equipment has passed working tests of all mechanic, electric and pneumatic units at factory. All materials and the spare parts have passed the complete careful control before delivery in a transport company.
- ▶ At equipment acceptance make the control on availability/absence of any transport damages.

4.1 TRANSPORTATION INSTRUCTIONS

- ▶ The machine should be standing upright and positioned centrally on top of a wooden pallet. While the machine is situated on the pallet, position the forklift arms under the pallet between the runners, keeping in mind that the machine is head heavy. Move the entire unit to an accessible area as close as possible to the final location.
- ▶ Carefully remove the packing frame surrounding the saw unit. Once completed, proceed by elevating the machine away from the pallet base using a sling harness wrapped around the cutting head of the saw. Ensure that the floor is as level as possible before finally positioning the machine to the desired location.



It is forbidden to be under the machine during loading and unloading.

1. At loading to forklift it is necessary to avoid damage of cables, cylinders, hoses, filter-regulator and control panels.
2. Means for moving should have dimensions corresponding for the machine.
3. Avoid blows of the machine tool in the course of moving.
4. Machine moving should be performed by a forklift.





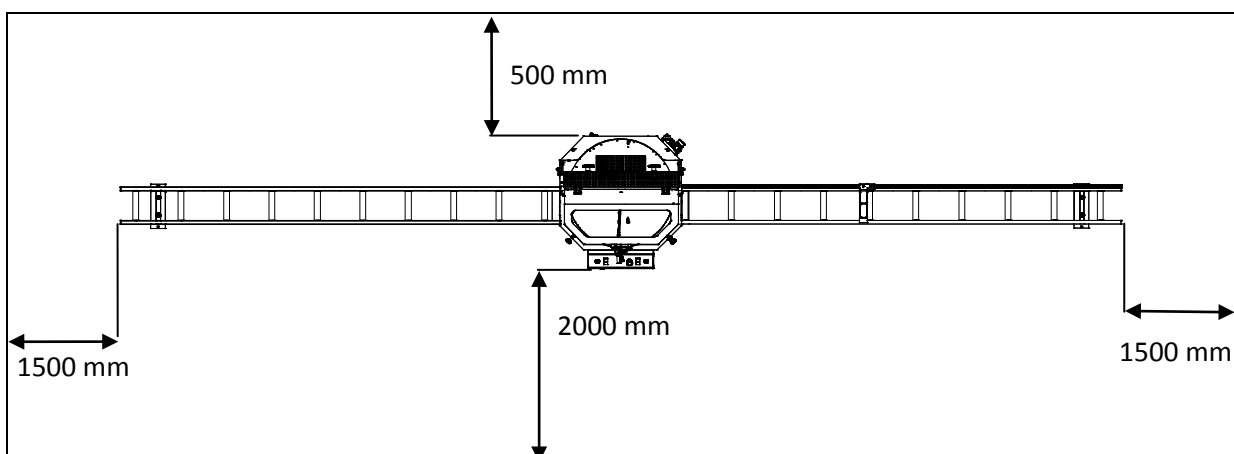

4.2 REQUIRED WORKING AREA

- ▶ For high-efficiency work of the machine it is recommended to place the machine in workshop with maintenance of indicators of the distances indicated by the manufacturer. A – B the placings shown on the plan, it is necessary to keep plots the free. The minimum recommended distance from the uppermost point of the machine tool to a ceiling constitutes 2 mt.



Picture 4.2-1 Required Working Area

4.3 INSTALLATION SETTINGS

	<ul style="list-style-type: none"> ▶ Care should be taken for the floor to be straight and sound the machine will be positioned. Note that there will be sufficient distance around the machine in order to work safely, for easy servicing and maneuvers.
	<ul style="list-style-type: none"> ▶ The machine should be scaled. The machine that is well scaled will reduce the vibration, working will be easier and the production and the quality will also increase.
	<ul style="list-style-type: none"> ▶ Pressure of air should constitute 6-8 Bar. Usage of a thick hose interferes with air pressure decrease on all length of a line. Besides, it is necessary to avoid hit of moisture for the prevention of breakage of valves and pneumocylinders. ▶ Warning: if there is no air dryer in the pneumatic system connection of machine, parts of the pneumatic group are not subject to warranty service!
	<ul style="list-style-type: none"> ▶ The electrical connections of the machine should be done by the service staff or qualified electrician.
	<ul style="list-style-type: none"> ▶ The used electric switchboard should correspond to norms of safety and electric standards. The voltage stabilizer should be connected to a line of a supply of electricity.
	<ul style="list-style-type: none"> ▶ The grounding contour prevents aggrieving to the user by wandering currents, for this reason the correct system and reliability of a contour of grounding has special importance. ▶ Grounding line should be connected to the machine body.
	<ul style="list-style-type: none"> ▶ Voltage changes, its increase and decrease is harmful and dangerous to the equipment. To prevent these events use a voltage stabilizer. Otherwise the manufacturer does not bear any responsibility for possible malfunctions. ▶ Warning: if there is no voltage stabilizer in electric system connection of the machine, parts of electric and pneumatic are not subject to warranty service!
	<ul style="list-style-type: none"> ▶ In the machine used a cable with 5 pins (3 phases + 1 neutral + 1 grounding), corresponding to IP 44 standards and the power of machine. It is necessary to ensure that similar standards for plug sockets.

4.4 FIRST CONNECTION

1. Remove the package.
2. Locate machine on an even horizontal place.
3. Connect electricity (380 V).
4. Checks the sequence of phases (3 phases + 1 neutral + 1 grounding).
5. Connect air pressure (6-8 bar).
6. Check oil level in filter-regulator.

- The first connection should be made by service team. The manufacturer does not bear responsibility for damages incurred by connection the machine by not service team.

First connection by service team:

- Eliminate failures occurred during transportation.
- Check the uniformity of machine installation.
- Check the electrical and air connections.
- Switch on the machine
- Instruct the operator of the machine
- Give instruction on the safety and maintenance of machine



Note: If in new connection machine does not work, then the cause could be the inconsistency of phases in the electrical network, so that motors does not rotate in the opposite direction, the machine is protected by a special control-phase relay. Changes of phases in the connection socket should be performed by service or qualified electrician.

- When phase sequence incorrect or the inclusion of an emergency stop, the emergency stop message displays on the screen. To return to the main menu, first you must disconnect the emergency stop or reverse phases and then push the "Reset".

5. PRINCIPLES OF WORK

5.1 MAIN SETTINGS

- ▶ All necessary factory options are performed on the equipment. At wear of mechanical units or details, at change of profile system it is necessary to change some options. Necessary options are given below.

5.1.1 MEASURE CALIBRATION

- ▶ Measure the profile after cutting. Set the dimension you get on the ruler (1) by the pointer (2), weakening its attachment.

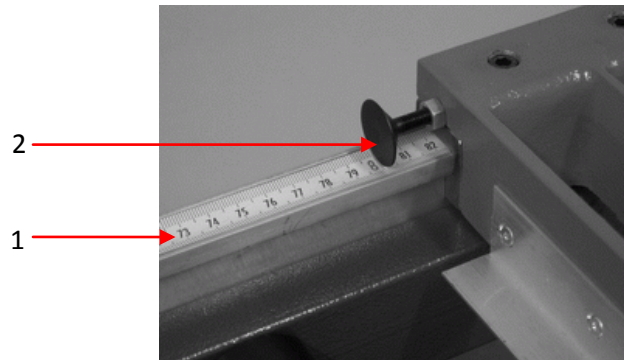

Picture 5.1-1 Measure calibration

5.2 CONTROL ELEMENTS

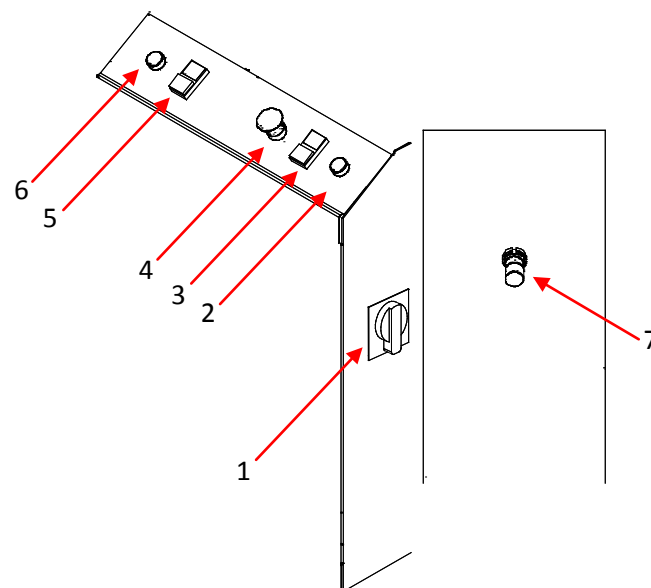

Picture 5.2-1 Control Panel

1. Power Switch
2. Button "START" cutting
3. Button "CLAMP – PULL OUT" for clamping kit
4. Emergency Stop
5. Button "START - STOP" turns motor ON/OFF
6. Button "START" cutting
7. Sawblade output speed regulator

5.3 OPERATION OF MACHINE

The below prerequisites should be ready in order for the machine to be ready to operate:

- ✓ Power switch ON.
- ✓ Phase control lamp ON.
- ✓ Front protection cover up.
- ✓ Profile clamping pistons back

Note: During the initial operation, the phase control lamp checking the rotation of the saw should be ON.



Before the operation starts it is necessary to be convinced of absence people (service staff, etc.) near to the machine which can receive damages at movement of units of the machine; the operator should be attentive for the purpose of protection of health of persons which can be near to it, also it is necessary to warn surround persons about machine operation.

When the machine is ready to operate, the below actions are taken:

1. Set the size on right measurement conveyor.
2. The motor is operated by pressing the Start button
3. The profile is placed to the table horizontally.
4. Push clamp button to clamp the profile.
5. Close the protection cover
6. Push and hold buttons for cutting start (2) & (6).
7. The saw carries out the profile cutting process by moving up.
8. The saw goes back by releasing the cutting button on the control panel, the clamping pistons release the profile.
9. The process is completed.
10. In case of an unexpected error the machine is stopped by pressing the emergency stop.

6. MAINTENANCE AND THE LUBRICATION OF THE MACHINE

1. All air and electrical energy should be disconnected before maintenance.
2. In order to disconnect the electric energy, set the power switch "OFF" position.
3. In order to disconnect the air completely, separate the air input hose from the machine.
4. Perform the cleaning of the machine every day. Clean the daily sawdust. The cleaning can be performed with an air gun.
5. Use only the lubrication products recommended by our factory.
6. Add oil by checking the filter-regulator for its oil level.
7. Electrical and pneumatic panels should be cleaned once a month with air against the dust and sawdust.
8. The dismantling and assembling process of the motor cutter ends should be performed by an expert.
9. If the clamping cylinders do not press the profile, the pressure should be checked from the air lubricator.
10. The machine needs at least 6 bar air pressure. Pressure should be followed.

Daily maintenance

- ▶ Clean machine and surround area with compressed area.
- ▶ Clean with duster oil, shaves, dust etc.
- ▶ Check bladesaw. Must be changed if blunt or saw damage occurs. See page 14 CHANGING THE BLADE
- ▶ Check condensate level in filter-regulator. See page 19 FILTER-REGULATOR

Weekly maintenance

- ▶ Check oil level in filter-regulator. See page 19 FILTER-REGULATOR
- ▶ Check oil feeding. See page 19 FILTER-REGULATOR

Monthly maintenance

- ▶ Check weekly maintenance

6.1 MAINTENANCE TABLE

	Daily	Weekly	Monthly
Clean machine and area from dust, oil etc.	X		
Check the sawblade	X		
Check the oil level in filter-regulator		X	
Check the oil feeding in filter-regulator		X	
Check the condensate level in filter-regulator	X		

6.2 MAGNETIC SENSOR

- ▶ There is a magnet inside the pneumatic cylinder and this magnet moves with the piston.
- ▶ The magnetic sensor connected to the surface of the piston open its contacts when it is effects by this magnet. If the position of the magnetic sensor changes that is to say it will not contact with the magnet so the signal will not go the PLC and therefore there will not be any action performed.

In this case the sensor is placed by moving forward or backward slightly in the arrow direction. (the light on the sensor turns on when the magnet contacts with the sensor and the sensor is fixed in that position so the problem will be solved).

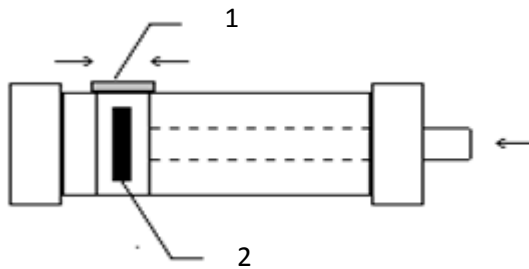

Picture 6.1-1 Sensor adjustment

1. Sensor
2. Piston and magnet

6.3 CHANGING THE BLADE

1. All air and electrical connections should be disconnected.
2. Protective covers must be removed.
3. The nuts on the motor spindle where the saw is installed are must be removed from the saw place by opening in the opposite direction to each others.
4. After the saw is replaced with the new one, the same procedure is reversed.
5. After the saw is replaced the covers are replaced too.



Wear gloves during the saw replacement.

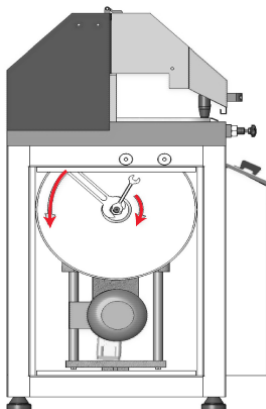

Picture 6.2-1 Blade changing

7. PNEUMATIC ELEMENTS

7.1 VALVE AND CYLINDER CONTROL

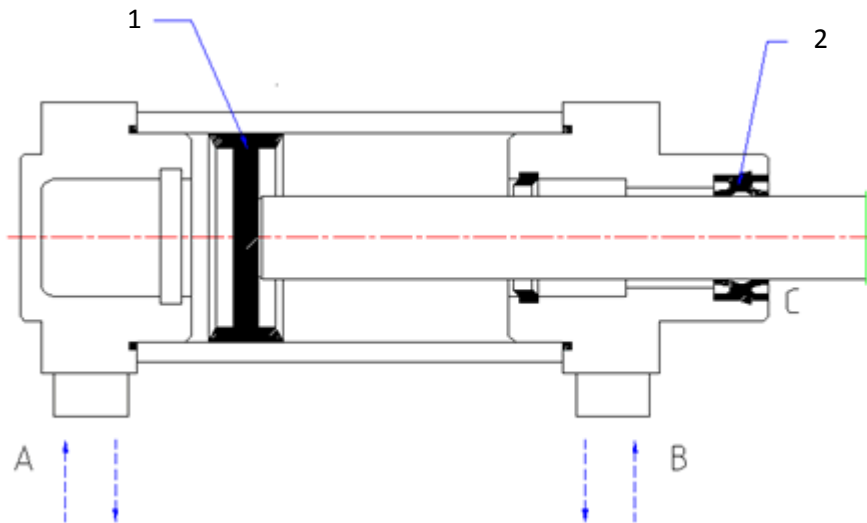

Picture 7.1-1 Valve and cylinder control

1. Piston cuff
2. Ring gasket

- ▶ If some operations on machine does not start to process or an air leakage occurs continuously in the valves, you should perform following:
 1. Look the pneumatic drawing to understand which cylinder works with which valve. If you don't have the pneumatic drawing, follow the input- output pipes of the cylinder to understand.
 2. Take off the air pipes connected to the A and B cable glands. Give air from A and check from B. If air comes from B, the cylinder seal must be malfunctioning.
 3. When air is given from B, the cylinder rod must still be giving out air, the neck seal C must be malfunctioning. If after checking them, A, B and C give out no air but there still is a leakage through the valves exhaust, check the valve.
 4. After you have checked them, if A, B and C give out no air but there still is a leakage through the valves exhaust, then check the valve.
 5. If the coil does not move by pressing the manual button, the coil may have broken down and it must be replaced. (A very low voice coming from coils when electric applied to them must be heard.) If the voice cannot be heard, check the electricity feed for coils.

7.2 CYLINDER SPEED ADJUSTMENT

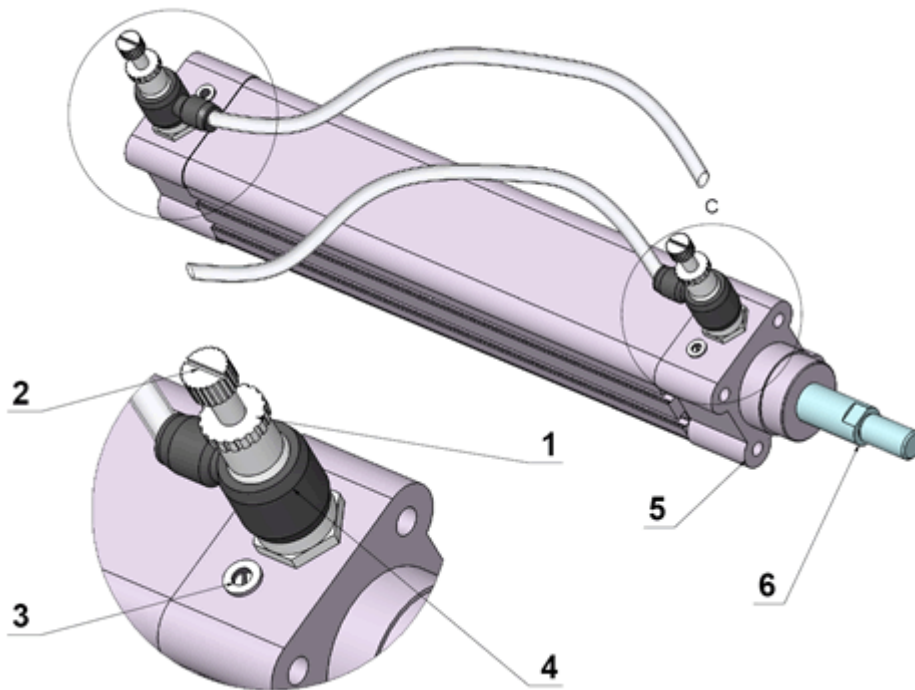

Picture 7.2-1 Cylinder speed adjustment

- ▶ The part adjustment nut numbered (1) is loosened. The adjustment bolt numbered (2) is fastened or loosened.
- ▶ Therefore the piston motor movement enabling speed is detected by adjusting the pressure affecting the piston (6) inside the cylinder (5). Also by loosening and opening the screw numbered (3) we can make the adjustment of padding.

NOTE: This process is applied in the same way for every cylinder with air reducer.

NOTE: It is used to prevent the shaking or the bumping in the last point of the direction in the opening or closing of the piston spindle.

7.3 HYDRAULIC SPEED CONTROL CYLINDER

(option for aluminium profiles cutting)

- ▶ The hydraulic speed control check normally couples with a pneumatic cylinder to provide uniform speed control.

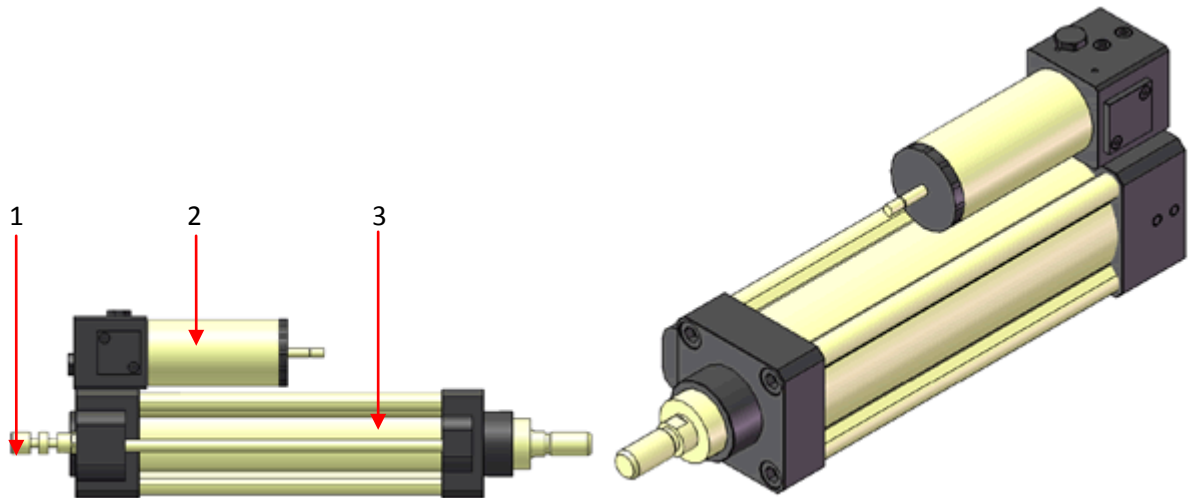

Picture 7.3-1 Hydraulic speed control cylinder

1. Speed control regulator
2. Reserve tank
3. Cylinder

- ▶ Speed control is adjustable by (1) regulator.

MAINTENANCE

- ▶ The speed control check is a closed system and there are no external factors that can adversely affect its function. Care however, has to be exercised not to allow the hydraulic fluid level to drop below the minimum indicated on the auxiliary tank. Should this occur, cavitation, or worse, an air pocket would result causing erratic control. Additional fluid should be put in exclusively through a unidirectional valve by means of an appropriate syringe (such as code number 1400.99.01). Excess fluid will be expelled through a vent into an appropriate container. It is necessary to completely disassemble the regulator and be sure to bleed the system to eliminate air pockets. We suggest that you create a vacuum before beginning to refill. This can be done with a small unidirectional valve turned up and repeatedly loaded with a syringe. The rod must be manually actuated successively releasing air through the valve using a small and pointed instrument.
- ▶ Oil for hydraulic and pneumatic circuits: Brobolube (Part Number: 9601480)

7.4 COOLING SYSTEM

(option for aluminium profiles cutting)

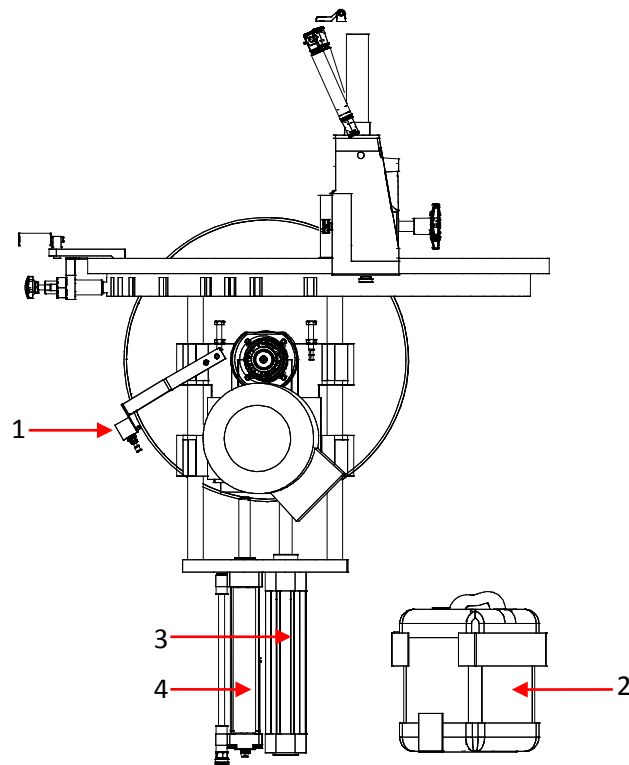

Picture 7.4-1 Cooling system

1. Coolant Spray speed regulator
2. Coolant tank
3. Pneumatic cylinder
4. Hydraulic speed control cylinder

- ▶ Cutting fluids are various fluids that are used in machining to cool and lubricate the cutting tool.



Before PVC profiles cutting operation started switch OFF the cooling system. Open the protective covers of cutting heads and clean the inside area from coolant.

- ▶ **Cutting fluid recommended to use:**

«Brobolube

7.5 FILTER-REGULATOR



The first condition for a pneumatic system to function properly is to supply enough and quality pressured air.

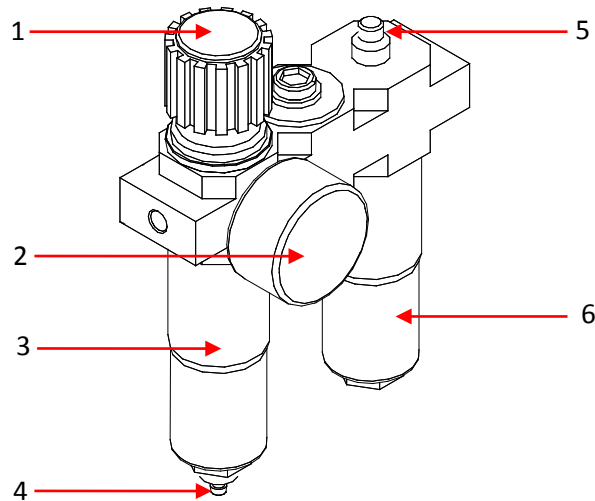

Picture 7.5-1 Filter-regulator

1. Pressure regulator
2. Air pressure manometer
3. Condensate unit
4. Nipple for condensate discharging
5. Regulating screw for oil feeding
6. Oil unit

► Filter cleans the compressed air of impurities, rust, pipe deposits and condensation.

SETTING INSTRUCTIONS

Pressure Adjustment: Regulator head shown with 1 is pulled up. If it is turned on in the clockwise direction lubricators' outlet air pressure will increase. If turned in counter clockwise direction, the pressure will decrease.

Condensate discharging: The emptying screw shown with number 4 is opened and the condensate liquid will discharge.

Oil filling: Oil unit shown with number 6 is pulled off by turning it on clockwise direction. Then pneumatic oil is added to the container.

Oil speed adjustment: If the adjustment screw shown by number 5 is turned in the clockwise direction, the oil speed will decrease if screw is turned in the opposite direction, it starts giving oil faster to the system. Oil output should be as **one drop / minute** at air feeding.

7.5.1 RECOMMENDED FILTER-REGULATOR OILS



1. ESSO NUTO H32
2. MOBIL DTE24SHELL TELLUS C10
3. SHELL TELLUS C10
4. FESTO SPECIAL OIL
5. PETROL OFISI SPINDURA 10
6. ARAL VITAM GF32
7. MOBIL DHE LIGHT

8. TROUBLESHOOTING

8.1 ACTIONS TO BE TAKEN DURING FAILURE

1. Check the machine feeding voltage working with 3 phase of get it checked.
2. There should be 6 atmospheric pressured air. You can read this value over the regulator-filter manometer of the machine.
3. Open the valve board cover of the machine. Check whether there is air leakage or not in air hoses, air connection elements or valves. Try to correct it if there is an air leakage.
4. Close the main power switch on the machine and open the cover of the electrical board. Check whether the two fuses in the board have blown or not. Correct if there is a break in the cables on the contactors and if there is looseness in the connector screws.

8.2 FAILURE – REASON – SOLUTION TABLE

FAILURE	REASON	SOLUTION TABLE
There is no movement	Electrical failure	Check the safety power switch. Check the fuses. Check the input phases.
	Air connection failure	Check the air connections. Check the air pressure on the filter-regulator.
Motor does not turning	Electrical failure. Thermic blown Motor failure.	Check the thermal relay. Change the motor.
Clamping cylinders do not clamp	Valve or cylinder failure Button contact failure	See page 15 VALVE AND CYLINDER CONTROL Check the button contact
Cutting head don't tilt to 45° degree	Valve and piston failure	See page 15 VALVE AND CYLINDER CONTROL
The system is leaking air	Air connection, joint places and union failure	Check the connection and joint places
Emergency stop buttons not working	Button contact failure	Check the contact
Sawblade is not moving forward	Valve and piston failure	See page 15 VALVE AND CYLINDER CONTROL
	Insufficient air pressure	See page 16 CYLINDER SPEED ADJUSTMENT
Going forward in vibration or going backward in vibration	Speed union settings unadjusted	See page 16 CYLINDER SPEED ADJUSTMENT
	Insufficient lubrication in pneumatic cylinder	See page 19 FILTER-REGULATOR
The sawdust going out the saw is yellow and there is an odor like the pvc burnt.	Saws are blunt or the teeth are broken	Sharpen the saw or replace with the new one. See page 14 CHANGING THE BLADE
	Saw proceeding is fast	See page 16 CYLINDER SPEED ADJUSTMENT

9. CIRCUIT DIAGRAMS

9.1 PNEUMATIC CIRCUIT DIAGRAM

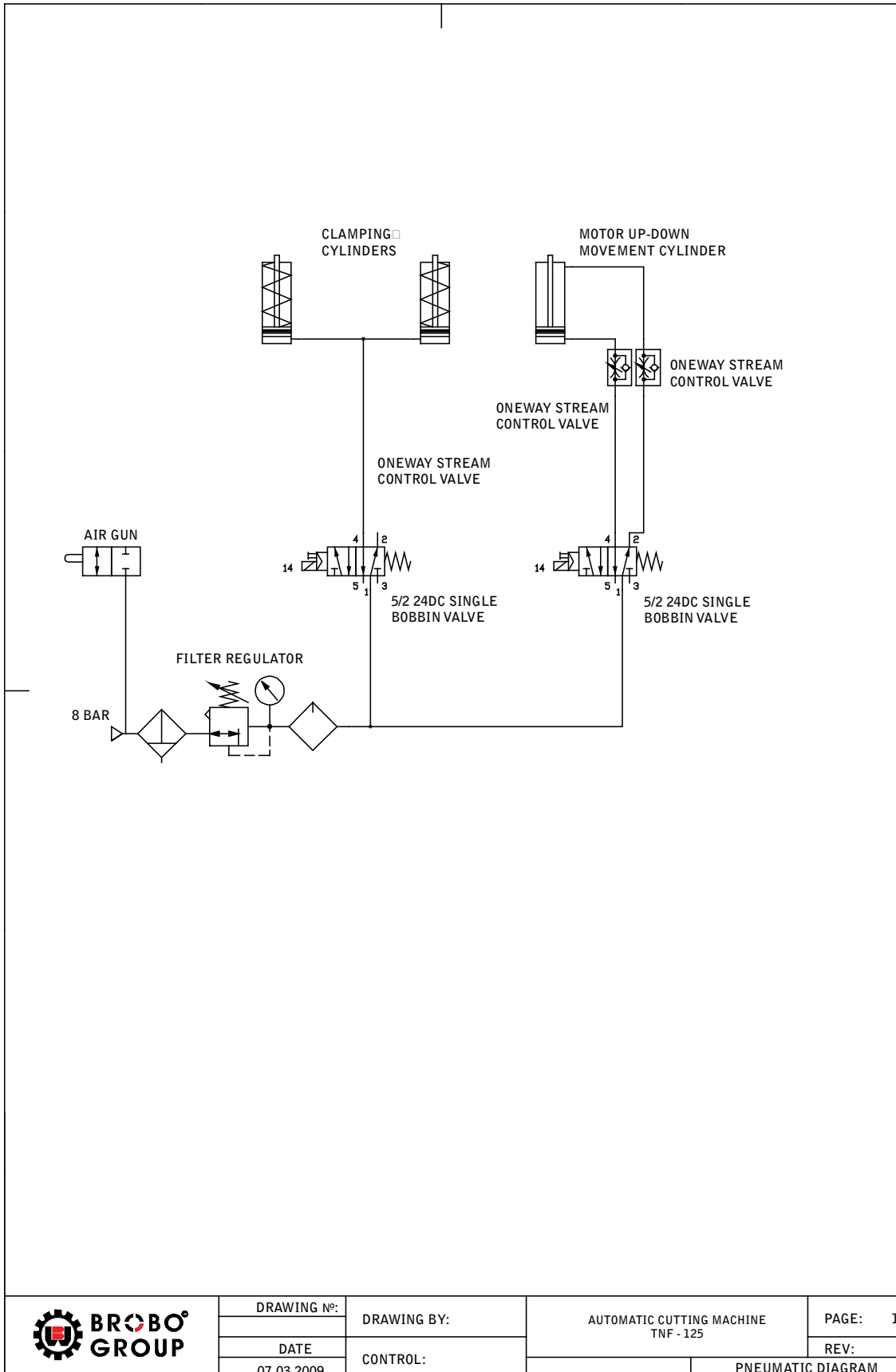

9.2 ELECTRIC CIRCUIT DIAGRAM

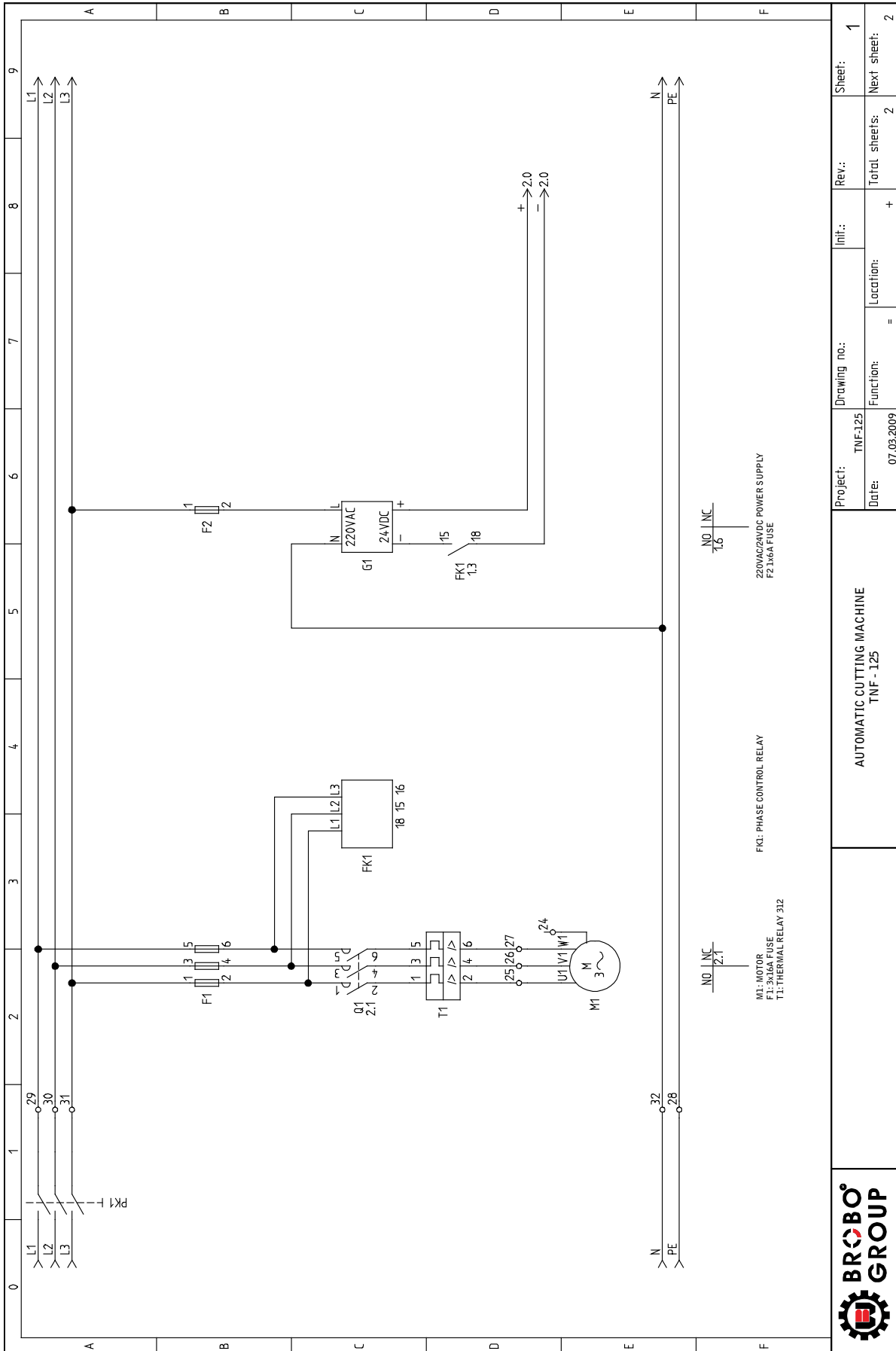

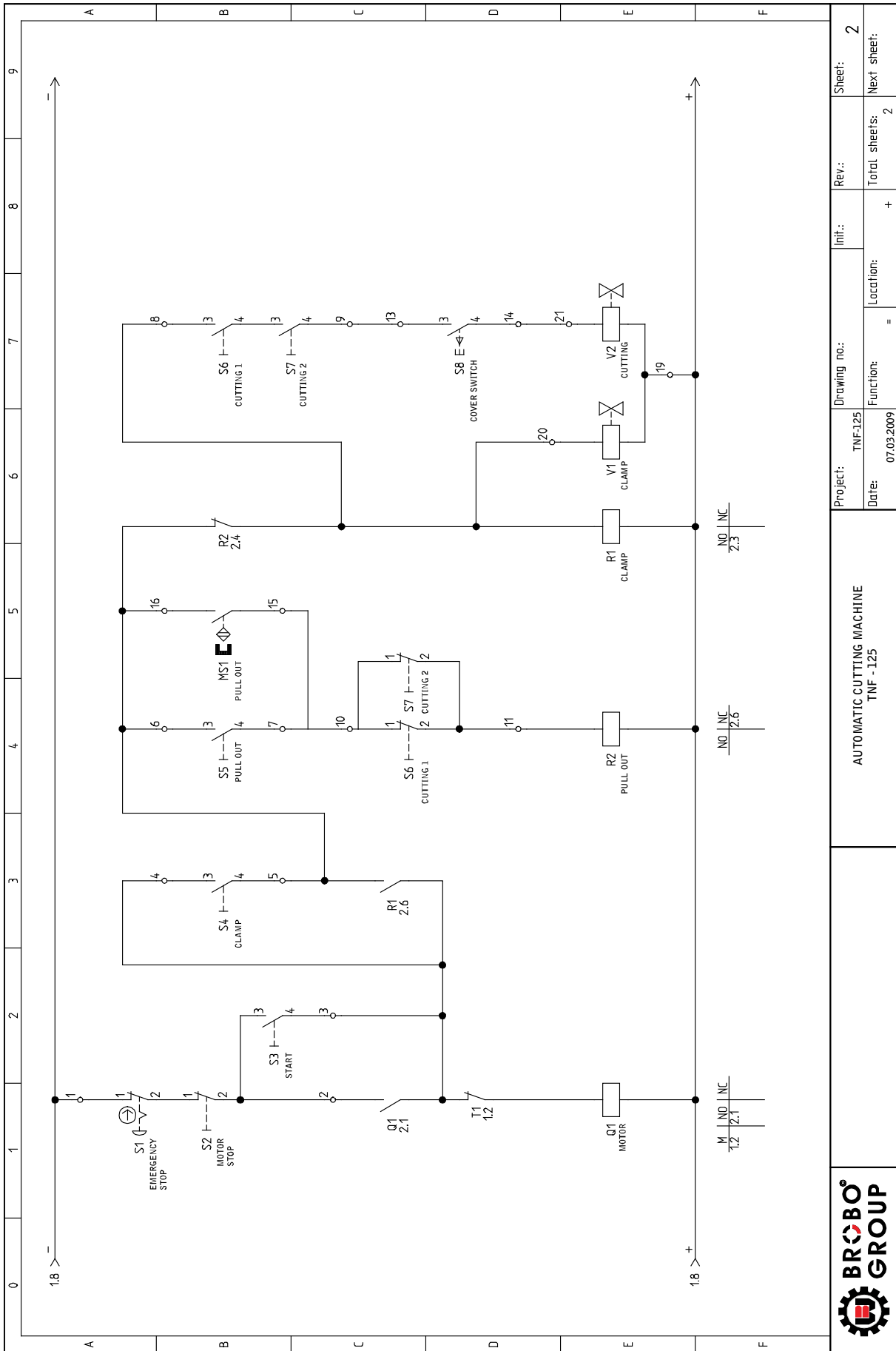

AUTOMATIC CUTTING MACHINE
TNF - 125

Project:	Project:	Init.:	Rev.:	Sheet:
TNF-125	TNF-125			2
Date:	Function:	Location:	Total sheets:	Next sheet:
07.03.2009	=		2	2

10. WARRANTY

1.1 The supplier warrants that all goods supplied by it, shall be free from defects in materials and workmanship for a period of twenty four (24) months from the date of delivery to the Customer. ("the Warranty Period"), on the following terms and conditions.

1.2 The Customer shall promptly provide written particulars to the supplier on becoming aware of any defect in the goods during the Warranty Period, and shall provide the Supplier with all necessary access, facilities and information to enable the Supplier to ascertain or verify the nature and the cause of the defect and to carry out its obligations under this warranty.

1.3 The Supplier's obligation under this warranty is limited to repairs of the defect goods and the Supplier is under no obligation to replace the goods or refund the value of the goods to the Customer.

1.4 If the goods are, in the opinion of the Supplier, not defective or if any defect is attributable to any one or more of the following circumstances then the Supplier is under no obligation whatsoever to the Customer:

1.4.1 The use of the goods for a purpose other than that for which they were intended to be used;

1.4.2 The repair, modification or alteration of the goods by any person other than the Supplier;

1.4.3 Where the defect has arisen due to misuse, neglect or accident, howsoever arising;

1.4.4 Where the defect has arisen due to installation of the goods which were, in the reasonable opinion of the Supplier, incorrectly carried out

1.4.5 Where the goods have not been correctly stored or maintained

1.4.6 Where the defect has arisen due to normal wear and tear on the goods

1.5 The Supplier is under no obligation under this warranty where the Customer has failed to observe the terms of payment for the goods or any other obligation imposed by the terms and conditions of this warranty.

1.6 In the event that the Supplier is supplying goods, which have been manufactured by third parties, the Customer shall be entitled to the benefit of any Manufacturer's Warranty in respect of such goods. The Customer acknowledges that the Supplier accepts no responsibility whatsoever for any Manufacturer's Warranty or any claim howsoever arising from the use of the goods, whether singularly or in combination with other products.

1.7 The Supplier shall not be liable for any indirect or consequential losses or expenses suffered by the Customer, howsoever caused.

1.8 Except as specifically set out herein, or in writing by way of catalogue or pamphlet or otherwise provided by the Supplier to the Customer any term, representation, condition or warranty in respect of the quality, condition or description of the goods, whether implied by statute, common law, trade usage, custom or otherwise, is hereby expressly excluded.

This warranty is given by Brobo Group Pty Ltd, ABN: 42 098 264 316

Address: 65-67 Williams Rd, Dandenong, VIC 3175

Ph: 03 9794 8751 Fax: 03 9794 8792

Email: info@brobo.com.au

This warranty is provided in addition to other rights and remedies you have under law: Our goods come with guarantees which cannot be excluded under the Australian Consumer Law. You are entitled to replacement or refund for a major failure and to compensation for other reasonably foreseeable loss or damage. You are also entitled to have the goods repaired or replaced if the goods fail to be of acceptable quality and the failure does not amount to a major failure.



The manufacturer reserves the right on production and instruction change.



BROBO GROUP®

A.C.N. 098 264 316
A.B.N. 42 098 264 316

BROBO WALDOWN (AUST) PTY. LTD.

65-67 Williams Rd, Dandenong, 3175
PO BOX 4274 Dandenong Sth, 3164
Victoria, AUSTRALIA.

Tel: 61 3 9794 8751
Fax: 61 3 9794 8792

Email: info@brobo.com.au
Website: www.brobo.com.au

