

## Union Tees

### Union Tees

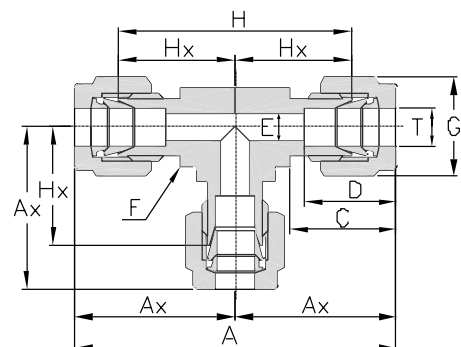

### ENGLISH UNITS

Model Number	T Tube O.D. in.	A in.	Ax in.	C in.	D in.	E in.	F Hex Flat in.	G Hex Flat in.	H in.	Hx in.
SS-UT-TF2	1/8	1.76	0.88	0.60	0.50	0.09	3/8	7/16	1.24	0.62
SS-UT-TF3	3/16*	1.92	0.96	0.63	0.54	0.12	7/16	1/2	1.40	0.70
SS-UT-TF4	1/4	2.12	1.06	0.70	0.60	0.19	1/2	9/16	1.54	0.77
SS-UT-TF5	5/16*	2.34	1.17	0.73	0.64	0.25	5/8	5/8	1.76	0.88
SS-UT-TF6	3/8	2.40	1.20	0.76	0.66	0.28	5/8	11/16	1.82	0.91
SS-UT-TF8	1/2	2.84	1.42	0.86	0.90	0.41	13/16	7/8	2.04	1.02
SS-UT-TF10	5/8*	3.06	1.53	0.86	0.96	0.50	1	1	2.26	1.13
SS-UT-TF12	3/4	3.14	1.57	0.86	0.96	0.62	1-1/16	1-1/8	2.34	1.17
SS-UT-TF16	1	3.86	1.93	1.04	1.23	0.88	1-3/8	1-1/2	2.90	1.45

### METRIC UNITS

Model Number	T Tube O.D. mm	A mm	Ax mm	C mm	D mm	E mm	F Hex Flat mm	G Hex Flat mm	H mm	Hx mm
SS-UT-TF3M	3	44.7	22.3	15.3	12.9	2.4	9.50	12	31.5	15.7
SS-UT-TF6M	6	53.9	27.0	17.7	15.3	4.8	12.7	14	39.1	19.6
SS-UT-TF8M	8	59.7	29.9	18.6	16.2	6.4	16.0	16	44.7	22.4
SS-UT-TF10M	10	63.0	31.5	19.5	17.2	7.9	20.5	19	47.8	23.9
SS-UT-TF12M	12	72.0	36.0	22.0	22.8	9.5	20.5	22	51.8	25.9
SS-UT-TF14M	14	77.6	38.8	22.0	24.4	11.1	25.4	25	57.4	28.7
SS-UT-TF16M	16*	77.6	38.8	22.0	24.4	12.7	25.4	25	57.4	28.7
SS-UT-TF18M	18*	79.5	38.8	22.0	24.4	15.1	27	30	59.4	29.7
SS-UT-TF22M	22*	89.3	44.6	22.0	26.0	18.3	35	32	69.1	34.5
SS-UT-TF25M	25*	98.3	49.1	26.5	31.3	21.8	35	38	73.7	36.8

\*: Consult factory