



BROBO GROUP®

A.C.N. 098 264 316
A.B.N. 42 098 264 316

BROBO WALDOWN (AUST) PTY. LTD.

65-67 Williams Rd, Dandenong, 3175
PO BOX 4274 Dandenong Sth, 3164
Victoria, AUSTRALIA.

Tel: 61 3 9794 8751

Fax: 61 3 9794 8792

Email: info@brobo.com.au

Website: www.brobo.com.au



Quality
ISO 9001

PRODUCT AND MAINTENANCE MANUAL

OHS SERIES METAL SAWS

MODEL No. S315A, S350D, S400B & SCV350 – 400 / Serial No's. C 29680~



YOUR BROBO DISTRIBUTOR IS:



- Precision Drilling Machines ● Tapping Machines ● Multi Head Drills ● Tool Grinders ●
- Tool Post Grinders ● Machine Vices ● Special Production Equipment ●
- Accessories ● Riveting Machines ● Pedestal Grinders ● Metal Cutting Saws ● Linishers ●

OPERATING MANUAL FOR BROBO GROUP MANUAL METAL CUTTING SAWS

TECHNICAL SPECIFICATION	3
CHAPTER 1: <u>Installation of the Machine</u>	
1.1 Unpacking and Handling the Machine	6
1.2 Parts Checklist	7
1.3 Minimum Requirements	7
1.4 Anchoring the Saw	8
1.5 Connection to Power Source	9
CHAPTER 2: <u>Safety and Accident Prevention</u>	
2.1 Operation of the Machine	10
2.1.1 Noise Level	11
2.1.2 Power Supply	11
2.2 General Requirements	11
2.3 Advice for the Operator	12
2.4 Machine Safety Devices	14
2.4.1 Reference Standards	14
CHAPTER 3: <u>Main Functions and Operation of the Machine</u>	
3.1.1 Cutting Head	15
3.1.2 Saw Safety Guard	15
3.1.3 Saw Handle (with 'Dead Man' Trigger Switch)	16
3.1.4 Main power standby & Speed selector switch	16
3.1.5 Manual Vice Clamp	16
3.2 Preparation for Operation	17
3.3 Operation Recommendations	18
CHAPTER 4: <u>Drawings, Layouts, Assembly and Spare Parts</u>	
4.1.1 Assembly Drawing (1 of 3)	19
4.1.2 Assembly Drawing (2 of 3)	20
4.1.3 Assembly Drawing (3 of 3)	22
4.2.1 Electrical Circuit 1PH/ 3PH & 3PH Dual Speed Circuit Diagram	23
4.2.2 Electrical Circuit 3PH with Dead Man Trigger (DMT)	24
4.3 Component Layout & Electrical Schematic Drawings (3PH)	25
4.4 Standard Saw Gearbox Assembly	26
4.5 Standard Manual Vice Assembly	27
4.6 Dual Manual Vice Assembly	28
CHAPTER 5: <u>Adjustments for the Saw Unit</u>	
5.1 Changing the Blade	29
5.2 Adjusting the Cutting Angle	30
5.3 Cutting and Feeding Speeds	30
5.4 Refilling the Lubricator	30
5.5 Adjusting the Brobolube Unit	31
5.5.1 Lubricating Oil Precautions – Health Hazard Information	31
CHAPTER 6: <u>Maintenance and Selection of Consumables</u>	
6.1 Role of the Operator	32
6.2 Maintenance Requirements	32
6.3 General Maintenance of Functioning Components	32
CHAPTER 7: <u>Troubleshoot</u>	
7.1 Troubleshooting For Blade and Cutting Problems	34
7.2 General Troubleshooting	36
APPENDIX	
i. Hazard/Risk Assessment	37
ii. Warranty	38

TECHNICAL SPECIFICATION

STANDARD BLADE SIZES

Outer Diameter (□ mm)	Thickness (mm)	Bore Size (mm)	Number of Teeth
250	2.0	32	140
300	2.5	40	160
350 *	2.5	40	180
400	3.0	40	200

TABLE 1. Standard Blade Sizes

(* - Recommendation)

BLADE SELECTION CHART

	Material Outer Diameter (□ mm)	Wall Thickness (mm)	Blade Diameter (□ mm) and Number of Teeth			
			300	315	350	400
HOLLOW CROSS-SECTION	20	1	300	320	350	400
		2	240	240	280	340
		3	180	180	220	240
	40	1	300	320	250	400
		2	220	220	260	280
		3	160	160	180	200
		4	140	140	160	180
	50	1	300	320	350	400
		2	220	220	280	300
		3	160	180	200	220
		4	140	160	180	200
		5	120	140	160	180
	80	1	280	300	320	360
		2	200	200	220	240
		3	180	200	200	220
		4	160	160	180	180
		5	140	140	160	180
	100	1		300	300	340
		2		220	200	220
		3		200	180	180
4			160	140	160	
5			140	120	140	
120	1			300	340	
	2			200	220	
	3			180	180	
	4			160	160	
	5			120	140	
SOLID SECTIONS	10		280	280	280	300
	20		160	160	200	240
	30		140	140	160	200
	40		120	120	140	140
	50		80	80	100	120
	60				80	100

TABLE 2. Blade Selection Chart



NOTE - CHART GUIDE ONLY

*This chart is issued as a **guide only**. Many other factors would attribute to the cutting performance of both the saw blade and the sawing machine. BROBO GROUP Pty. Ltd. will not accept any responsibility for the blade selection and/or machine breakages or unsatisfactory cutting performance of both the blade and/or the machine as a direct result of the selection.*

Blade Type:

AISI M-Z High Speed Steel (62-64 HRC, Hollow Ground)

Blue-oxide coated for:

- Greater durability,
- Better coolant conveyance to the cutting edge,
- Reduces galling or "pick-up" on sides of the blade,
- Reduces brittleness of the steel.

Tooth Form:Bevelled on alternate sides - up to 180 teeth, or
High-rolling, low-finishing teeth, "triple-chip" - above 180 teeth**Drive Pin Holes (Qty · □ · PCD):**

(S315 & S350 Series)	2 · 8mm · 55mm
(S400 Series)	2 · 10.5mm · 64mm

Worm Gear Drive Ratio (S315/S350/S400): 1:33 Reduction**Sound Level (dBA):** 85 - 90 dB(A) Maximum**MOTOR SPECIFICATIONS**

Motor Type (Hz)	Phase	Voltage (V)	RPM	Kilowatt (kW)
50Hz Power Supply	1	240	1400	1.7
50Hz Power Supply	3	415	1400 / 2800	1.5 / 2.2
50Hz Power Supply	3	415	700 / 1400	1.1 / 1.5
60Hz Power Supply	1	230	1700	1.7
60Hz Power Supply	3	220	850 / 1700	1.1 / 1.5
60Hz Power Supply	3	440	850 / 1700	1.5 / 2.2
60Hz Power Supply	3	220	1700 / 3400	1.1 / 1.5

TABLE 3. Motor Specifications

BLADE SPINDLE RPM

Motor Type			BLADE SPEEDS					
			S315		S350		S400	
Frequency (Hz)	Phase	RPM	RPM	m/min	RPM	m/min	RPM	m/min
50	3	700	21	20	21	23	21	27
	1 / 3	1400	42	40	42	47	42	53
	3	2800	85	80	85	93	85	106
			RPM	ft/min	RPM	ft/min	RPM	ft/min
60 (USA)	3	850	26	84	26	93	26	106
	1 / 3	1700	52	168	52	186	52	212
	3	3400	103	334	103	370	103	424

TABLE 4. Blade Spindle RPM

VICE CLAMPS

Manual Vice	
Clamping Range (mm)	0 - 135 (145mm w/o wear plates)
Air Requirements:	
Air Consumption (L):	
Clamp Working Pressure (kPa):	
Maximum Pressure (kPa):	
Pneumatic Stroke (mm):	
Clamping Force (N):	

TABLE 5. Vice Clamps

CUTTING RANGE





Cross Sectional Profile	Angle	Cutting Range (mm)								
		S315		S350		S400				
	90°	90	3 1/2"		115	4 1/2"		130	5 1/8"	
	45°	85	3 3/8"		110	4 5/16"		120	4 11/16"	
	90°	80 · 80	3 1/8" · 3 1/8"		100 · 100	4" · 4"		110 · 110	4 5/16" · 4 5/16"	
	45°	75 · 75	3" · 3"		85 · 85	3 3/8" · 3 3/8"		95 · 95	3 3/4" · 3 3/4"	
	90°	75 · 100	3" · 4"		85 · 135	3 3/8" · 5 5/16"		100 · 135	4" · 5 5/16"	
	45°	80 · 65	3 1/8" · 2 1/2"		75 · 95	3" · 3 3/4"		100 · 95	4" · 3 3/4"	
	90°	50	STD 2"	AUTO 3"	60	STD 2 3/4"	AUTO 3 1/2"	60	STD 2 3/4"	AUTO 3 1/2"

TABLE 6. Cutting Range

Note: The above values are based on a full size blade. The capacities will reduce accordingly when a worn blade is resharpened.

DIMENSIONAL SPECIFICATIONS

Base Dimensions (L · W · H): 560 · 530 · 1800 mm

Table Working Height: 968 mm

SAW WEIGHT

	Un-Packed Weight (kg)		Packed Weight (kg)	
S315/S350/S400 Saw Unit	136kg	(300lb.)	150kg	(330lb.)
Coolant Tank Complete	17kg	(42lb.)	17kg	(42lb.)
Sheet Metal Stand S315/S350/S400	28kg	(62lb.)	28kg	(62lb.)
Manual Vice Unit	25kg	(55lb.)	25kg	(55lb.)

TABLE 7. Saw Weight

CHAPTER 1 - Installation of the Machine

1.1 Unpacking and Handling the Machine



WARNING – HEAD HEAVY MACHINES

The metal sawing machines are heaviest where the saw heads are fitted and as such, care must be taken while relocating or moving the machines.

Upon receiving the **Brobo Group S315/S350/S400 Series Metal Cutting Saw**, the machine should be standing upright and positioned centrally on top of a wooden pallet. While the machine is situated on the pallet, position the forklift arms under the pallet between the runners, keeping in mind that the machine is **head heavy**. Move the entire unit to an accessible area as close as possible to the final location.

Carefully remove the wooden frame surrounding the saw unit (Figure 1). Once completed, proceed by elevating the machine away from the pallet base using a sling harness wrapped around the cutting head of the saw. Ensure that the floor is as level as possible before finally positioning the machine to the desired location.

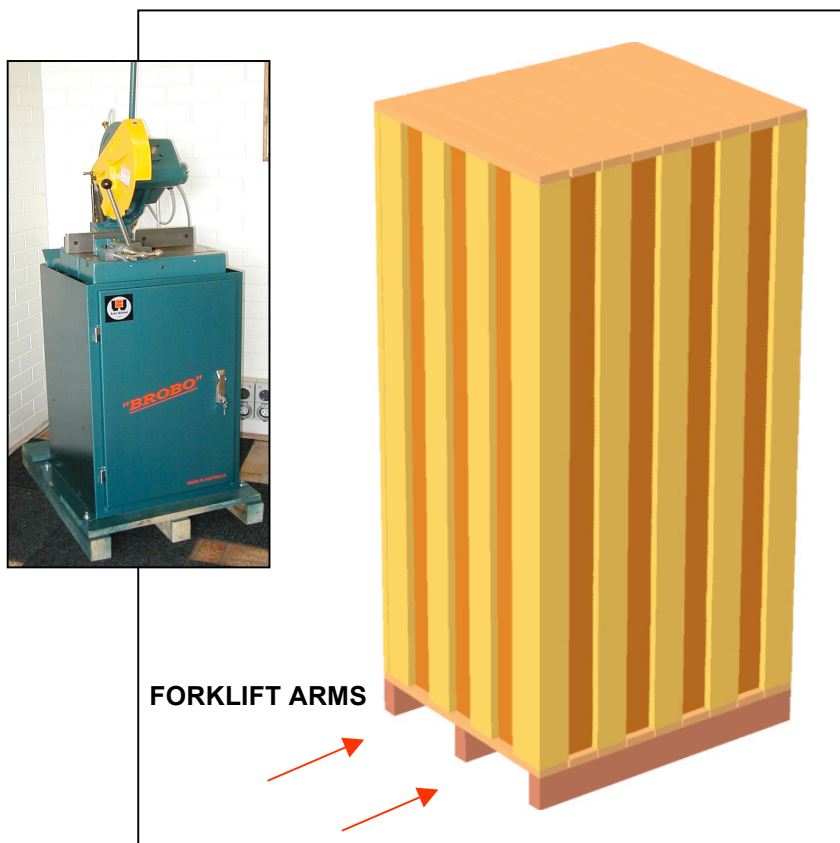

FIGURE 1. Handling of Metal Cutting Saw Unit

PLEASE OBSERVE AND FOLLOW THE INSTALLATION INSTRUCTIONS ON PAGE 7

1.2 Parts Checklist

Along with the saw unit, check that the following accessories, packed "loose", are included as follows:

A. STANDARD ACCESSORIES

- i. 1 · Saw Blade
- ii. 1 · Operating Handle
- iii. 1 · Service Kit (Hexagon wrenches 5", 10" & 14")
- iv. 1 · Operating Manual

B. OPTIONAL ACCESSORIES

Part Number	Description
9311060	Standard Adjustable Length Stop (600mm)
9501540	'Brobo-Rule' Series Manual Micro-Adjustment Length Stop <ul style="list-style-type: none">▪ Available in 1.5m, 3.0m, 4.5m or 6.0m lengths▪ Field Kit includes rail, tape, micro-stop and extension arm.
9501120 9501180	Roller Conveyor <ul style="list-style-type: none">▪ Available in 1.5m or 3.0m lengths▪ Available with Plastic or Steel Rollers▪ 75mm or 150mm Pitch
9311060	Mechanical Manual Vice Clamp
9301300	Fabricated Sheet Metal Stand
9301450	Angle Iron Stand
9301400	Trigger 'Deadman' Switch
93018800	Brobolube Lubricants
-	Additional Blade(s) - <i>Custom to Client Requirements</i>

1.3 Minimum Requirements

For the machine to function correctly, the room in which the saw unit is to be installed must be in the vicinity of, and satisfy the following conditions:

- *415/240V Power Supply*
- *Ambient Temperature* - From -10°C to +50°C.
- *Relative Humidity*: Not more than 90%.
- *Lighting*: More than 500 LUX.



WARNING – OPERATING VOLTAGE VARIATION

Each saw model has an inbuilt safety system to protect it against voltage variations. However, for the machine to perform efficiently, ensure that the saw unit operates within ±10% limits of the recommended voltage of the motor.

1.4 Anchoring the Saw

Prior to anchoring the saw unit, take into considerations the requirements mentioned in *Section 1.3* and *Section 2.2*, and other aspects regarding the usage of the machine such as accessibility to cut parts and safe access for the operator.

The base of fabricated stand (if applicable), in which the saw head rests on, is anchored to the floor by 4 · M12 bolts provided. For added stability, it is strongly recommended that the machine stand be fastened to the floor by using loxins (not provided). When positioning and fastening the unit, please refer to the hole locations shown in *Figure 2*.

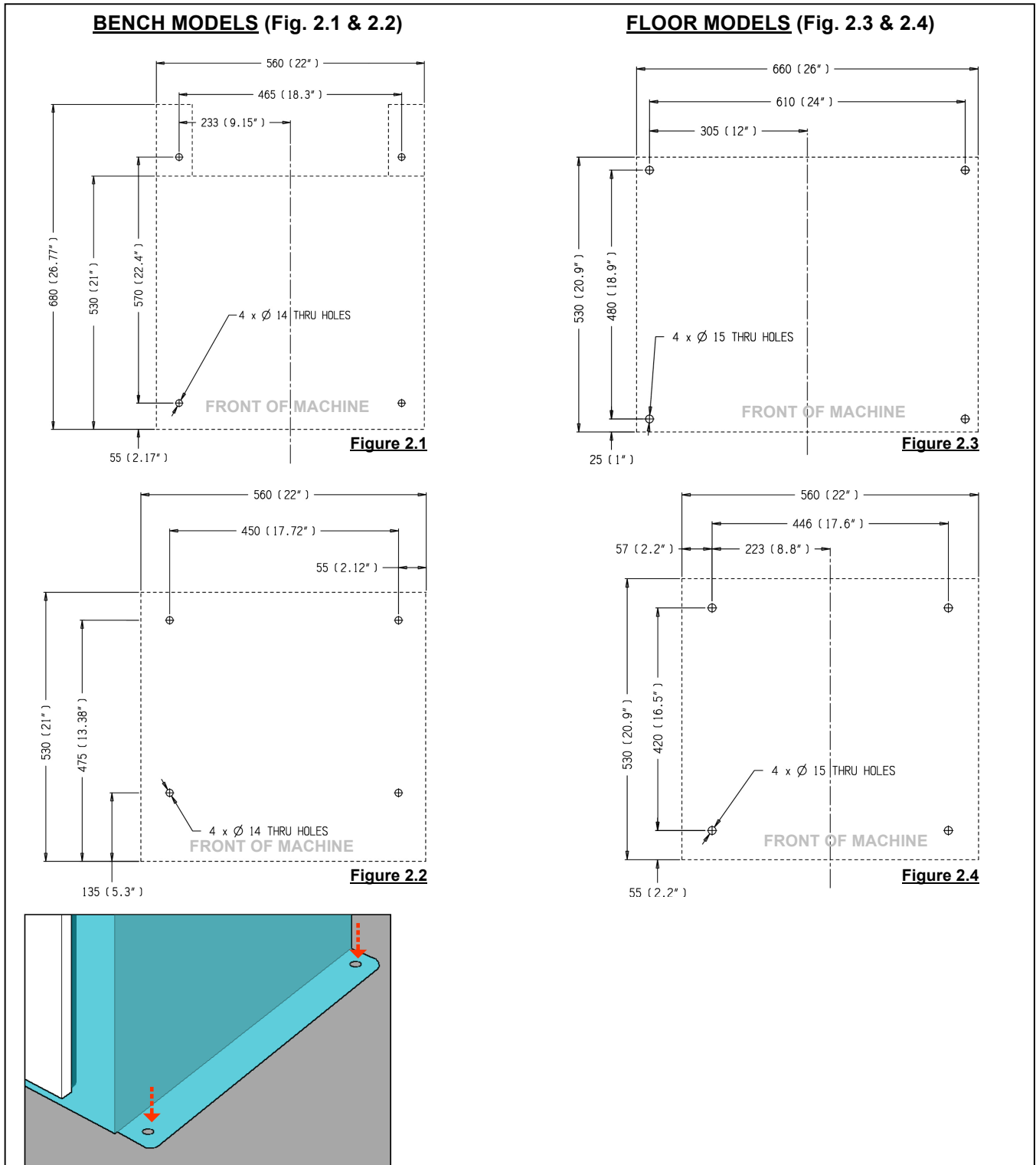

1.5 Connection to Power Source

Before connecting the machine to the power supply, check that the socket is not connected in series with other machines. This condition is critical for the ideal operation of the saw unit.

(Refer to Figure 4 for wiring of “4-CORE” power supply cable from the machine to a power plug. Note that single-phase machines are supplied in Australia with **15-amp** plug).

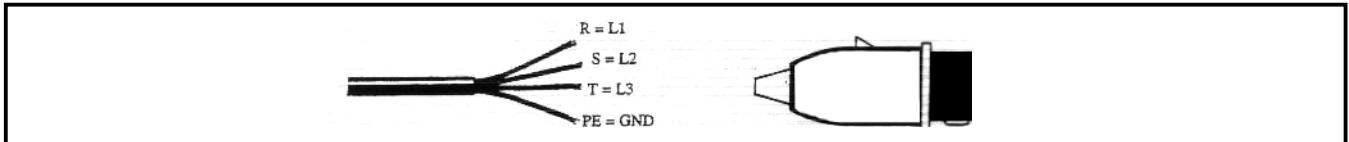

Figure 4. Connection for “4-CORE” Wire System with Neutral

Single and Three Phase

- i. Single phase machines are provided with three pins, 15 amps rated plugs and leads for connection to 240V, 50Hz power supply in Australia.
- ii. Three phase machines should be fitted with a suitable, approved four pin plugs (ie. three phase and earthing - **not provided**)
- iii. Check the power supplied and motor specifications before plugging in the machine. Check terminal connection on dual voltage motor terminal box and connect it accordingly to the corresponding voltage supply.
- iv. If dual motor is requested, the motor is **always** connected to the higher voltage, unless otherwise specified prior to order being placed.

To connect the machine to the power supply, proceed as follows:

- 1) Insert the power plug into the socket, while ensuring that the mains voltage is compatible for which the saw unit is operating at.
- 2) Switch the saw on by rotating the control switch located on the saw head assembly as shown in *Figure 5* below.

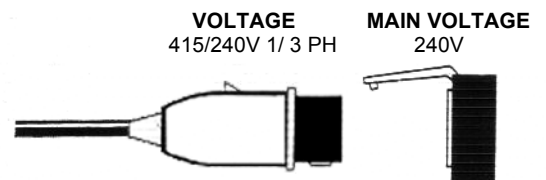

Figure 5. Main Control Switch

- 3) Check that the motor is operating in the *correct* direction, that is the blade is rotating downwards and into the direction of the vice clamps.
- 4) Ensure that all electrical leads and cables (including supply leads) are maintained in a good condition and away from sharp objects. All leads should be replaced if cut, sliced or damaged in any way.

Brobo Group S315/S350/S400 Series Metal Cutting Saw is now ready for use. *Chapter 3* provides a detailed description of the various features of the saw and its operating cycles.

CHAPTER 2 - Safety and Accident Prevention

The **Brobo Group S315/S350/S400 Series Metal Cutting Saw** has been designed and manufactured in accordance to Australian Standards. It is **HIGHLY RECOMMENDED** that the instructions and warnings contained in this chapter be carefully followed for correct usage of the machine.

2.1 Operation of the Machine

The **BW S315/S350/S400 Series Metal Cutting Saw** is specifically design to cut ferrous and non-ferrous metal cross sections with solid or thin-walled profiles. Other types of material and machining are not compatible for use with the specifications of the saw. ***This machine involves a high-speed blade rotation; therefore extreme caution is required when operating the device.***

The employer is responsible for instructing the personnel who, in turn, are obliged to inform the operator of any accident risks, safety devices, noise emission and accident prevention regulations provided for by national and international laws governing the use of the machine. ***The operator must be fully aware of the position and functions of all the machine's controls.***

All those concerned must strictly adhere to ALL instructions, warnings and accident prevention standards in this manual.

The following definitions are those provided for by the **EEC DIRECTIVE ON MACHINERY No. 98/37/CE**:

- **Danger Zone** - any zone in and/or around a machine in which the presence of a person constitutes a risk for the safety and health of that person.
- **Person Exposed** - any person finding him or herself, either completely or partly in a danger zone.
- **Operator** - the person or persons given the responsibility of installing, operating, adjusting, maintaining, cleaning, repairing, and transporting the machine.



WARNING – UNAUTHORISED MODIFICATIONS/REPLACEMENTS/USE

The manufacturer declines any responsibility whatsoever, either civil or criminal, in the case of unauthorised interference or replacement of one or more parts or assemblies on the machine, or if accessories, tools and consumable materials used are different from those recommended by the manufacturer, or if the machine is inserted in a plant system and its proper function is altered.

2.1.1 Noise Level

The noise level of an idling metal saw, fitted with a **180-tooth blade** (supplied as standard by Brobo Group) has been measured to be **below 85 dBA**. This complies with the **Australian Occupational Health and Safety (Noise) Regulations 1992**.

Please note that peak impulse noise levels will be experienced due to variables including blade characteristics, type, and condition. This will also vary accordingly depending on the size and type of sample being cut. Under these circumstances, management should make available to the operator(s) the appropriate hearing protection equipment as prescribed under the above stated act.

2.1.2 Power Supply

The 415/240V power supply requirements for this machine are of a high level and unauthorised interference and or inadequate maintenance could result in a situation that could put the operator at risk. A **qualified** electrical engineer should always be assigned to maintain and repair the system.

2.1.3 Compressed Air Supply

Various functions of the saw are carried out via the use of 6kPa compressed air. During these operations, situations would arise where machine parts and materials are clamped together and would potentially pose a serious safety issue to an inexperienced operator. Operators should be thoroughly instructed about these hazards. **Only a qualified electrician should carry out regular maintenance of this system.**

2.2 General Requirements

Lighting

Insufficient lighting during the operation of the saw unit would constitute a safety hazard for the people concerned. For this reason, the user of the machine must provide adequate lighting in the working area to eliminate areas in shadow, whilst also preventing dazzling illumination sources (reference standard **ISO 8995 - 2002 'Lighting of Indoor Workplaces'**).

Connection

Check that the power supply cables, compressed air supply (if applicable) and coolant system complies with, and are operating within the acceptable range of the saw capabilities. **Faulty, damaged or worn components must be replaced immediately.**

Earthing Systems

The installation of the earthing system must comply with the requirements stated in the **IEC Standards Part 195: Earthing and Protection Against Electric Shocks 1998**.

Position of the Operator

The user controlling the machine saw operations must be positioned as shown in the diagram below.

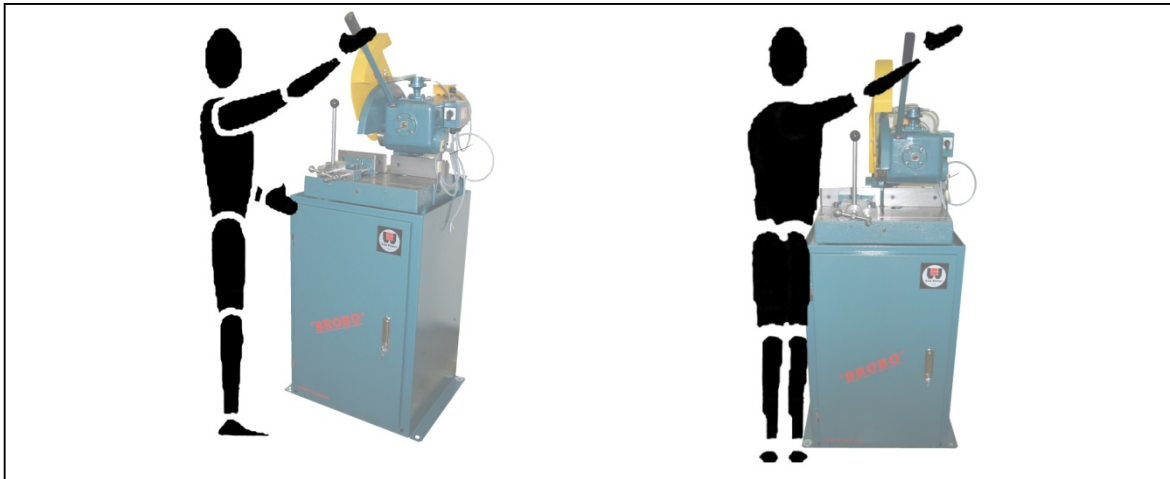

Figure 6. Correct Position for Operating Saw Unit

2.3 Advice for the Operator



Protective eyewear or goggles must be worn at all times while attending and operating the metal saw.



Do not attempt to operate the machine unless all safety guards are in operation. The guard must fully cover the blade when the head is in the uppermost position.



Ensure that hands and arms are kept clear of the cutting zone when the machine is operating.



Do not wear oversize clothing with long sleeves and oversize gloves, bracelets, necklaces or any other loose object that may become entangled in the machine's blade during cutting. Long hair must be tied back or placed in a hair net.



Always disconnect the power supply to the machine before carrying out any maintenance work or adjustments. This includes cases of abnormal operations of the machine.



Any maintenance work performed on the hydraulic, pneumatic or coolant systems must be carried out only after the pressure in the system has been released.



The operator **MUST NOT** conduct any risky operations or those not required for the cutting in course (eg. remove swarf shavings from the machine while cutting). **Never move the saw while the machine is operating.**



Always keep the workplace as clean as possible. Remove equipment, tools or any other objects from the cutting zone.



Support the work piece on both sides of the machine to prevent it falling or jamming during the cutting cycle.

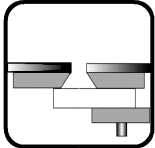

Ensure that the specimen being cut is secured firmly in the vice clamps and the machine has been correctly set. Figure 7 show some examples on how to correctly clamp different specimen profiles. Before commencing the cut, be sure the vice(s) is securely clamped and the machine set-up is correct.

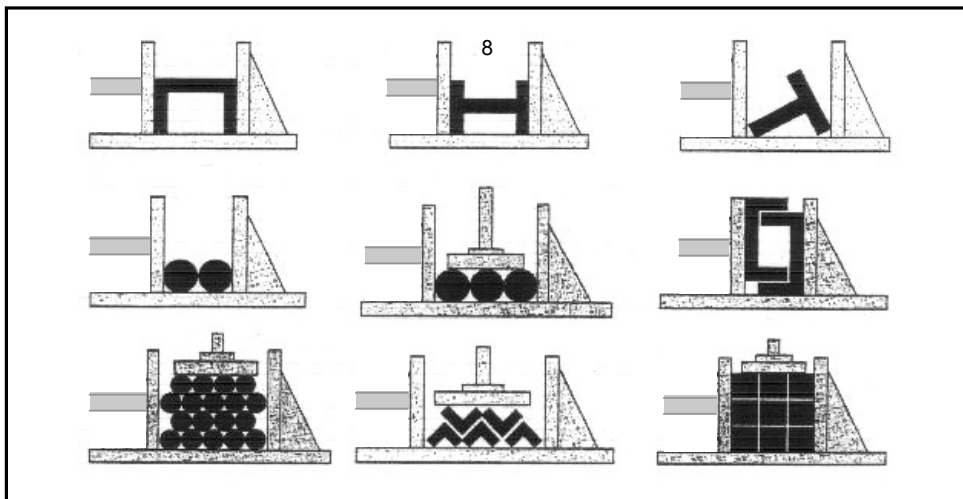
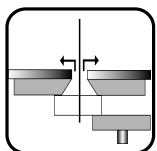

Figure 7. Correct Clamping of Cutting Specimens



Do not use cutting blades of different sizes to those recommended to the machine's specifications. Always follow safe practices and inspection procedures when installing blades (Please refer to section 5.1 *Changing the Blade*).



When cutting very small specimens, **ensure that the workpiece is not dragged behind the back fence support**, where it could get lodged behind the blade.

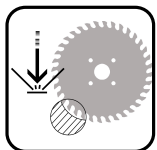

If the blade jams during a cut, activate the emergency stop function immediately. Do not continue forcing the blade through. This could damage the blade, the specimen or be a cause for potential injury to the operator.

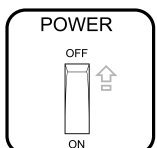

Always turn off the machine before carrying out any repair work. Consult the Brobo Group Engineering Department in the country in which the machine was initially purchased.

2.4 Machine Safety Devices

This product and maintenance manual is not purely intended as a guide for the usage, operation and maintenance of the saw unit in a strictly production environment; it is instead an instrument to providing information on how to use the machine correctly and safely. The following standards listed in section 2.4.1, which are applicable to the **BW S315/S350/S400 Series Metal Cutting Saw**, are those specified by the EEC Committee that governs safety of machinery, health and safety at work, personal protection and safeguarding of the work environment. In addition, the saw also complies with the Australian Standards regarding the safeguarding and general requirements for electrical equipment.

2.4.1 Reference Standards

MACHINE SAFETY

- *EEC Directive No. 98/37/CE* - Machines Directive
- *EEC Directive No. 91/368 - 94/68* - Amends sections of EEC Directive No. 98/37/CE relating to machine safety
- *EEC Directive No. 73/23* - Low Voltage Directive
- *AS4024.1 - 1996* - Safeguarding of Machinery

HEALTH AND SAFETY AT WORK

- *AS3100 - 2002* - General Requirements for Electrical Equipment
- *OH. & S. 1995.81/1995* - Compliance References
- *EEC Directive No. 80/1107; 83/477; 86/188; 88/188; 88/642* - Protection of workers against risks caused by exposure to physical, chemical and biological agents in workplace
- *EEC Directive No. 73/23 and Special EEC Directives No. 89/654; 89/655* - Improvements in health and safety at work

CHAPTER 3 - Main Functions and Operation of the Machine

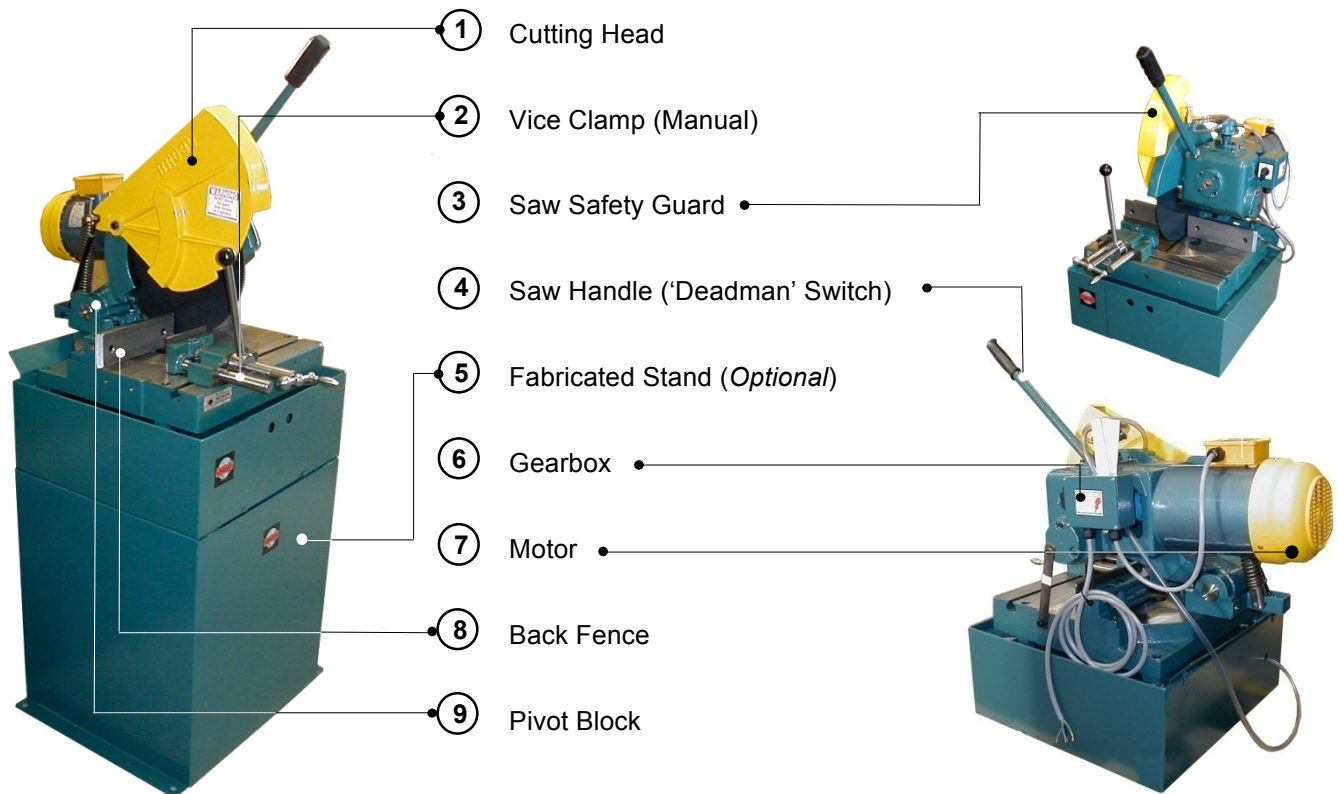

3.1.1 Cutting Head

As the name suggests, the cutting head is the focal area where most of the specimen cutting takes place. Thus, correct saw blade selection such as size, number of teeth and tooth pitch are all critical factors that determines the overall performance and quality of the final cuts. In addition, the use of correct saw blade provides minimum burr to the work piece while maximising the safety to the operator during each cutting procedure.

3.1.2 Saw Safety Guard

The primary purpose of the saw safety guard is to protect the user from the spinning blade. It also functions as a safety device to protect the operator from any broken tooth, swarf or high-velocity particles that might be dislodged by the cutting process.



3.1.3 Saw Handle (with 'Dead Man' Trigger Switch)

Although comes as a standard, the saw handle can be installed with a 'Dead Man' type trigger switch enabled instant switching at the operators control. This particular configuration allows for increased efficiency and safety.



Figure 9. Saw Handle

3.1.4 Main Power Standby & Speed Selector Switch

The rotary Main power switch also serves as the speed selector switch. When the speed is selected the saw is set to "STANDBY" mode. The "STANDBY" lamp illuminates to provide a warning to personnel the saw is at the ready. AT any time the "Dead Man" trigger is activated the saw will run.



STANDBY LAMP

3.1.5 Manual Vice Clamp

The manual vice clamp lever allows speedy clamping of material with ergonomically designed clamp lock.

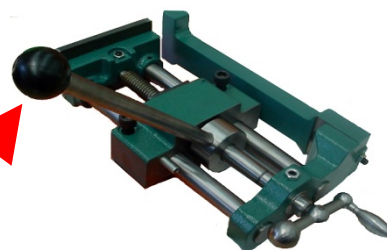

MANUAL VICE CLAMP LEVER

3.2 Preparation for Operation

The following procedure is recommended for the correct cutting using the **BW S315/S350/S400 Series Metal Cutting Saw**.



WARNING – SAFETY GEAR

Protective clothing, safety glasses and gloves should always be worn while loading parts, operating the machine, or undertaking any maintenance work on the saw.

PROCEDURE

- i) Using a non-flammable and toxic free solvent, clean the machine to remove any corrosion protective coating prior to use.
- ii) Ensure that both the air and electric power systems are turned on, where applicable. The electrical power source must be available before any pneumatic functions will operate.
- iii) To adjust the angle of the cutting surface, if necessary, loosen the 4 bolts, as shown in *Figure 10*. Fine-tune the angle required, then replace and re-tighten the 4 bolts.
- iv) Place the cutting specimen you wish to cut into the vice clamps. Manually adjust the clamps so that the jaws are clamped firmly to the workpiece. With a pneumatic vice, manually adjust the clamps to a clearance of **3 - 7mm**. (For correct clamping of material, please refer to *section 2.3 Advice for the Operator*). **NOTE** -The vice clamps advance with an approximate **10mm pneumatic stroke** to apply a clamping pressure of 6 bar (87 psi).
- v) Position the vice clamps and component as close to the blade as possible without interfering with the travel of the blade or guard. Vice relocation is required whenever the head angle is altered.
- vi) For pneumatic vices, set the vice clamping pressure from the pressure regulators located on the main control unit door. *If for any reason this pressure is not available on a continuous basis, the regulator on the air service unit must be set slightly below the available line pressure, and the safety low-pressure indicator valve needs to be reset to correspond with the new available pressure. The need to change the pressure is necessary to allow for lighter materials with hollow cross sections to be cut without deforming the walls thicknesses.*
- vii) To initiate the cutting process, either turn the switch to **1** or **2** settings, or press the **START** buttons.
 - Vice jaws automatically close and applies clamping pressure.
 - Position blade to commence cutting through component and maintaining a constant forward feed cutting rate until the end of the stroke.
 - Return saw cutting head to the initial rest position.
 - Vice clamps release workpiece.
- viii) Machine is ready for the next cutting cycle.

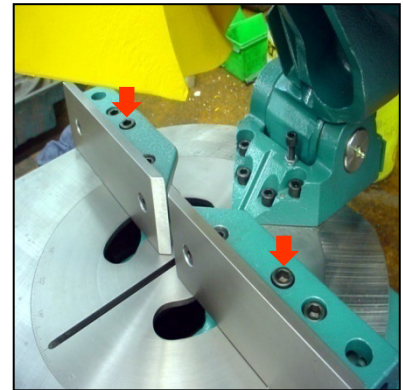

Figure 10. Angular Adjustment Bolts



WARNING - BLADE JAMMING

If the saw blade jams during a cut, engage the **EMERGENCY STOP** immediately. Remove the part, check that the blade is not damage and if need be, replace the blade.

3.3 Operation Recommendations

- Select the correct saw blade with the correct tooth pitch and form to suit the material to be cut to provide minimum burr and maximum blade lifespan.
- Use the smallest diameter blade and coarsest pitch that is practical within the required speed and material limitations.
- Generally use a tooth pitch to give 2 - 4 teeth engagement with the material during cutting.
- Ensure that sufficient coolant is flowing over the cutting teeth.
- Do not allow the machine's gearbox to run idle in the upright position for more than **3 minutes** otherwise, damage can occur to the drive system.
- The rate of feed affects the quality of the final cut and blade life. This varies also by the material and cross-sectional dimensions. When cutting stainless steel or high carbon steel (**Brinell Hardness above 200**), the slowest speed machine should be used together with a cobalt type high speed steel blade.
- When manually feeding the saw head, keep in mind to maintain a steady, continuous pressure, thus **avoiding work hardening** on the cutting piece. Avoid 'forcing' the blade through the material as this might damage or break the blade.
- As a rule of thumb **the softer the component, the faster the rate of speed**. Thus, it is recommended that slower speeds be used for hard and tough materials and higher speeds for soft, ductile materials. Note that for non-ferrous materials such as brass, copper, aluminium etc. require much faster speeds than provided on this machine. If these are the majority of materials cut, a *Brobo NF Series* machine should be considered.

4.2.2 Electrical Circuit 3PH with Dead Man Trigger (DMT)

QTY	DESCRIPTION	UNIT	REMARKS
26	8715310	1	CHEESE HEAD SLOTTED SCREW M5 X 20
25	8725650	3	LOCKWASHER Ø 5
24	8725210	1	EYELET Ø 5 MIN INSULATED
23	8705700	2	HEX NUT M5
22	9105040	1	DP. HANDLE SWITCH WITH ENCLOSURE
21	9305140	1	HEX LOCK NUT M20 X 1.5
20	9104010	1	DP. HANDLE BAR Ø21.3 X 355 LG
19	9304400	1	DP. SWITCH LEAD 2 CORE 32/0.20
18	9304850	1	MOTOR LEAD - 3 PHASE
17	8725720	2	FLAT HEAD SLOTTED SCREW M4 X 16
16	9615480	1	PLUG TIEZ. 480
15	9615500	1	SOCKET TIEZ. 550
14	8745180	12	CABLE TIE 142 MM LONG
13	8745440	8	BOOTLACE PINS BLP150
12	8745590	1	SINGLE SOLIDCORE INS. WIRE Ø 1.4 X 1 METRE
11	8705760	2	FLAT WASHER Ø 4
10	8705680	2	HEX NUT M4
9	8705900	2	LOCKWASHER Ø 5/32
8	8735410	4	CHEESE HEAD SLOTTED SCREW M4 X 10
7	915220	1	CONTACTOR 24V AC
6	9315190	1	TRANSFORMER 220-440/24V 50/60 Hz
5	9304810	1	ENCLOSURE - LARGE
4	9305180	1	SWITCH ROTARY CAM - 3 PH
3	9305200	1	LABEL - ELECTRICAL WARNING
2	9305900	3	CORROCLAMP R20
1	9304870	1	SUPPLY LEAD - 3 PHASE

NOTES:

- ITEM 1 CONSISTS OF 4 CORE 30/0.25 FLEX WITH 1 OFF H3115 EYELET FOR EARTH, AND 7 OFF BLP150 BOOT LACE PINS.
- ITEM 18 CONSISTS OF 7 CORE 30/0.25 FLEX WITH 2 OFF H3115 EYELETS FOR EARTH, AND 12 OFF BLP150 BOOT LACE PINS.
- ITEM 19 CONSISTS OF 2 CORE 32/0.20 FLEX, ONE END STRIP 13mm, OTHER END CRIMP WITH 2X SPADE LUG (FIGICI 25.6.4.06) OR SOLDER.
- ALL OTHER WIRES CONNECTING BETWEEN SWITCHGEAR AND COMPONENTS TO HAVE BLP150 BOOT LACE PINS.

REV	DESCRIPTION	DATE	BY	CHKD
E	PAN 8725210 WAS 8735400. 8735380 DELETED	15-08-02	M.G.	15-08-02
D	PAN'S 9615480, 9615500 WERE 9305480, 9305500.	9-04-98	M.G.	9-04-98
C	REDRAWN ON COMPUTER, REVISED AND SCHEMATIC ADDED	11-10-95	M.G.	11-10-95
B	ITEM 12 WAS 8705900 FLEX CABLE	7-03-94	G.F.	7-03-94
A	ITEMS 15 & 16 WERE 930517/F & 930517/M	3-12-93	G.F.	3-12-93

DRG/PART No.	9301400
TITL	ELECTRICAL ASSY FOR 3 PHASE SWS WITH DMT HANDLE
REV	N/A
DATE	11 Oct 95
BY	M.G.
CHKD	M.G.
MATERIALS	BRBDD WALDOW
DRAWN	BRBDD WALDOW
SCALE	1:1
SHEET	1 OF 1
REVISED	9301400
CUST. NO.	
PROJ. NO.	
JOB NO.	
CITY	
STATE	
COUNTRY	

4.3 Component Layout & Electrical Schematic Drawings (3PH)

13	9105040	1	TRIGGER SWITCH (N/D Contact)
12	9104010	1	OPERATING HANDLE BAR
11	8745100	1	2-CORE CABLE (1.0mm)
10	9615490	1	PLUG
9	9315220	1	24V CONTACTOR (MOELLER, DILEH-10)
8	9315190	1	TRANSFORMER (415V/240V/24V)
7	9615500	4	FEMALE SOCKET
6	8715310	3	EARTH STUD (M5 x 20)
5	8745140	9	4-CORE CABLE POWER SUPPLY (1.5mm)
4	8745150	6	7-CORE CABLE MOTOR SUPPLY (1.5mm)
3	9305600	3	CABLE GLAND
2	9354810	3	ENCLOSURE
1	9305180	1	2-SPEED SWITCH (MOELLER, TO-48441)

DET. PART NO.		DATE		NAME & MATERIAL		SHEET		REMARK	
Drawn	J.L.	Date	10/03/07	Scale	1:?	Sub Assembly		BROBO WALDOWN	
Project No.	-	Manufacture Qty.	-	Per Unit	-	AS SHOWN		AUSTRALIA PTY LTD	
Ref/Spec.	N/A	Title				ELECTRICAL SCHEMATIC DRAWINGS		Org No.	Def. No.
								Revision	

COMPONENT LAYOUT & ELECTRICAL SCHEMATIC DRAWINGS (3PH with DMT)

<p>DRG/PART No.</p> <p>DO NOT SCALE COMMERCIAL STOCK SIZES EXCEPTED AND UNLESS OTHERWISE NOTED TOLERANCES ON DIMENSIONS ARE: METRIC Size To Mech. Cost* 6 mm ± 0.1 ± 0.5 30 mm ± 0.2 ± 1.0 100 mm ± 0.3 ± 1.5 300 mm ± 0.5 ± 2.0 1000 mm ± 0.6 ± 3.0 2000 mm ± 1.2 ± 5.0 * INCLUDES STRUCTURAL STEEL WORK. REMOVE ALL BURRS AND SHARP EDGES BY 0.3 x 45° UNLESS OTHERWISE STATED SURFACE FINISH</p> <table border="1" style="width: 100%; border-collapse: collapse;"> <tr> <th colspan="2">Roughness Value</th> </tr> <tr> <th>Net Um</th> <th>Grade No.</th> </tr> <tr> <td>50</td> <td>N12</td> </tr> <tr> <td>25</td> <td>N11</td> </tr> <tr> <td>12.5</td> <td>N10</td> </tr> <tr> <td>6.3</td> <td>N9</td> </tr> <tr> <td>3.2</td> <td>N8</td> </tr> <tr> <td>1.6</td> <td>N7</td> </tr> <tr> <td>0.8</td> <td>N6</td> </tr> <tr> <td>0.4</td> <td>N5</td> </tr> <tr> <td>0.2</td> <td>N4</td> </tr> <tr> <td>0.1</td> <td>N3</td> </tr> <tr> <td>0.05</td> <td>N2</td> </tr> <tr> <td>0.025</td> <td>N1</td> </tr> </table> <p>DRAWING PRACTICE TO AS TLO PROJECTION SYSTEM (UNLESS NOTED)</p> <p>3RD ANGLE</p> <p>ANGULARITY TOLERANCE < 0° 7'</p> <p>CONCENTRICITY 0.1 mm</p> <p>THIS DESIGN OR DRAWING IS NOT SOLD BUT LEFT AND IS SUBJECT TO RECALL REPRODUCTIONS OF THIS DRAWING IN ANY MATERIAL FORM ARE RESERVED TO BROBO WALDOWN (AUST) Pty. Ltd. UNDER COPYRIGHT LAW.</p>	Roughness Value		Net Um	Grade No.	50	N12	25	N11	12.5	N10	6.3	N9	3.2	N8	1.6	N7	0.8	N6	0.4	N5	0.2	N4	0.1	N3	0.05	N2	0.025	N1	<p style="text-align: right;">CADDY A3</p>
Roughness Value																													
Net Um	Grade No.																												
50	N12																												
25	N11																												
12.5	N10																												
6.3	N9																												
3.2	N8																												
1.6	N7																												
0.8	N6																												
0.4	N5																												
0.2	N4																												
0.1	N3																												
0.05	N2																												
0.025	N1																												

4.4 Standard Saw Gearbox Assembly

DRG/PART No.

DO NOT SCALE

COMMERCIAL STOCK SIZES EXCEPTED AND UNLESS OTHERWISE NOTED TOLERANCES ON DIMENSIONS ARE:

Size To	Mach.	Cast**
6 mm	± 0.1	± 0.5
30 mm	± 0.2	± 1.0
100 mm	± 0.3	± 1.5
300 mm	± 0.5	± 2.0
1000 mm	± 0.6	± 3.0
2000 mm	± 1.2	± 5.0

* INCLUDES STRUCTURAL STEEL WORK.

REMOVE ALL BURRS AND SHARP EDGES BY 0.3 x 45° UNLESS OTHERWISE STATED

SURFACE FINISH

Roughness Value	Grade No.
Met Umm	

50	N12
25	N11
12.5	N10
6.3	N9
3.2	N8
1.6	N7
0.8	N6
0.4	N5
0.2	N4
0.1	N3
0.05	N2
0.025	N1

DRAWING PRACTICE TO AS 1100 - PROJECTION SYSTEM (UNLESS NOTED)



ANGULARITY TOLERANCE < 0° 7'

CONCENTRICITY 0.1 mm

THIS DESIGN OR DRAWING IS NOT SOLD, BUT LENT AND IS SUBJECT TO RECALL. REPRODUCTIONS OF THIS DRAWING IN ANY MATERIAL FORM ARE RESERVED TO BROBO WALDOWN (AUST) Pty. Ltd. UNDER COPYRIGHT LAW.

ITEM/PART No.	DESCRIPTION	QTY
1	8705070 SOC HD CAPSCREW M6 x 20	4
2	8705840 SPRING WASHER Ø 6	14
3	9312100 RETAINING RING	1
4	9315040 SEAL PR B135 Ø 52 x Ø 30 x 7	1
5	9305030 TAPER ROLLER BEARING 30306	1
6	9304430 KEY - WORKSHAFT	1
7	9314000 WORKSHAFT	1
8	9305020 TAPER ROLLER BEARING 30206	1
9	9512000 GEARBOX (SAW HEAD)	1
10	9305350 SHIM - Ø 35 x Ø 25	2
11	8705420 FLAT HD SOC SCREW M10 x 25	1
12	9302110 RETAINING RING	1
13	8705090 SOC HD CAPSCREW M6 x 25	3
14	9304130 RETAINER WASHER	1
15	9324070 TOP COVER PLATE	1
16	9304017 PIN - COOLANT PUMP	1
17	8705120 SOC HD CAPSCREW M6 x 20	2
18	8405450 COOLANT PUMP & GASKET	1
19	8705050 SPRING WASHER Ø 8	2
20	8705060 SOC HD CAPSCREW M6 x 16	10
21	9305250 HANDLE GRIP	1
22	9304110 OPERATING HANDLE	1
23	8405010 OIL WINDOW AND GASKET	1
24	9302120 COVER PLATE - FRONT	1
25	9305350 SHIM - Ø 50 x Ø 62 x 0.1	*
26	9305140 LOCKOUT H20 x 1.5	1
27	9314050 WORMWHEEL	1
28	9305010 SEAL PR 1277 Ø 70 x Ø 90 x 10	1
29	9314420 KEY - MAIN SPINDLE	1
30	9304080 MAIN SPINDLE	1
31	9304030 SPRING UPPER BRACKET	1
32	8705490 SOC SETSCREW M6 x 16	1
33	9315090 SUMP PLUG 1/2" NPT - NOT SHOWN	1

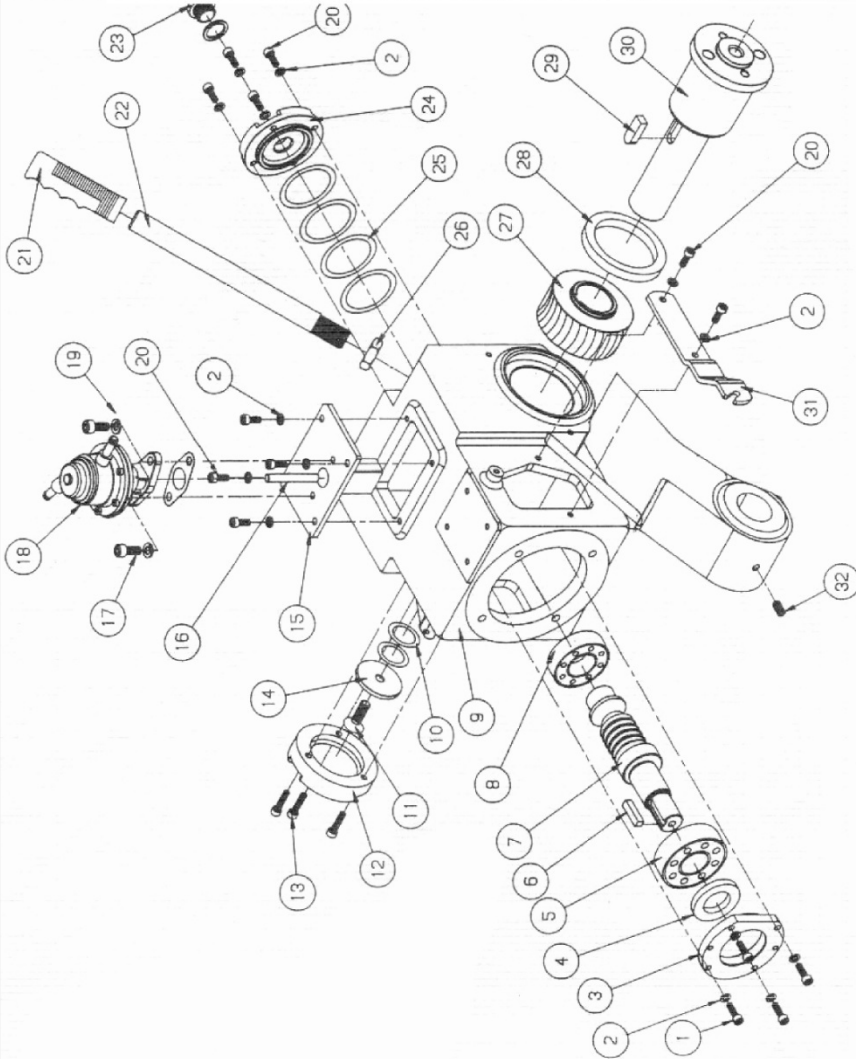

* THE NUMBER OF SHIMS - AS REQUIRED

Det. Part No.	Qty.	Name & Material	Sheet	Remark
Raw Mat. #.	Drawn	Checked	Scale	1:??
AS LISTED	JL	-	Sub Assy	
Mass in kg.	Date	Date	Layout No.	
N/A	28/02/06			
Mat./Spec	Titled	STANDARD SAW GEARBOX ASSEMBLY		
AS LISTED		Drg No.	Revision	



CADKEY A4

4.5 Standard Manual Vice Assembly

DRG/PART No. 9311060

DO NOT SCALE
 COMMERCIAL STOCK SIZES
 UNLESS OTHERWISE NOTED
 DIMENSIONS ON
 DIMENSIONS ON
 (METHOD)
 Size To Inch Casts
 6 mm 4 0.1 4 0.5
 100 mm 4 0.3 4 1.5
 100 mm 4 0.5 4 2.0
 2000 mm 4 1.2 4 5.0
 * INCLUDES STRUCTURAL
 STEEL WORK.
 REMOVE ALL BURS AND
 SHARP EDGES BY 0.3 X .45°
 UNLESS OTHERWISE STATED

Surface Finish	Symbol	Designation	Grade	Material
ROUGH	12.5	N12		
MED	6.3	N6.3		
FINE	3.2	N3.2		
POLISH	0.8	N0.8		
LAP	0.1	N0.1		

DRAWING PRACTICE TO BE FOLLOWED UNLESS NOTED OTHERWISE
 AND HANDLE
 AMBIGUITY TOLERANCE
 < 0° 7'
 DIMENSIONS
 0.1 mm
 THIS DESIGN OR DRAWING IS
 NOT SUBJECT TO RECALL
 REPRODUCTIONS OF THIS
 DRAWING ARE HEREBY FORBIDDEN
 FROM BEING ISSUED TO
 ANY OTHER PARTY WITHOUT
 THE WRITTEN PERMISSION OF
 UNDER COPYRIGHT LAW.

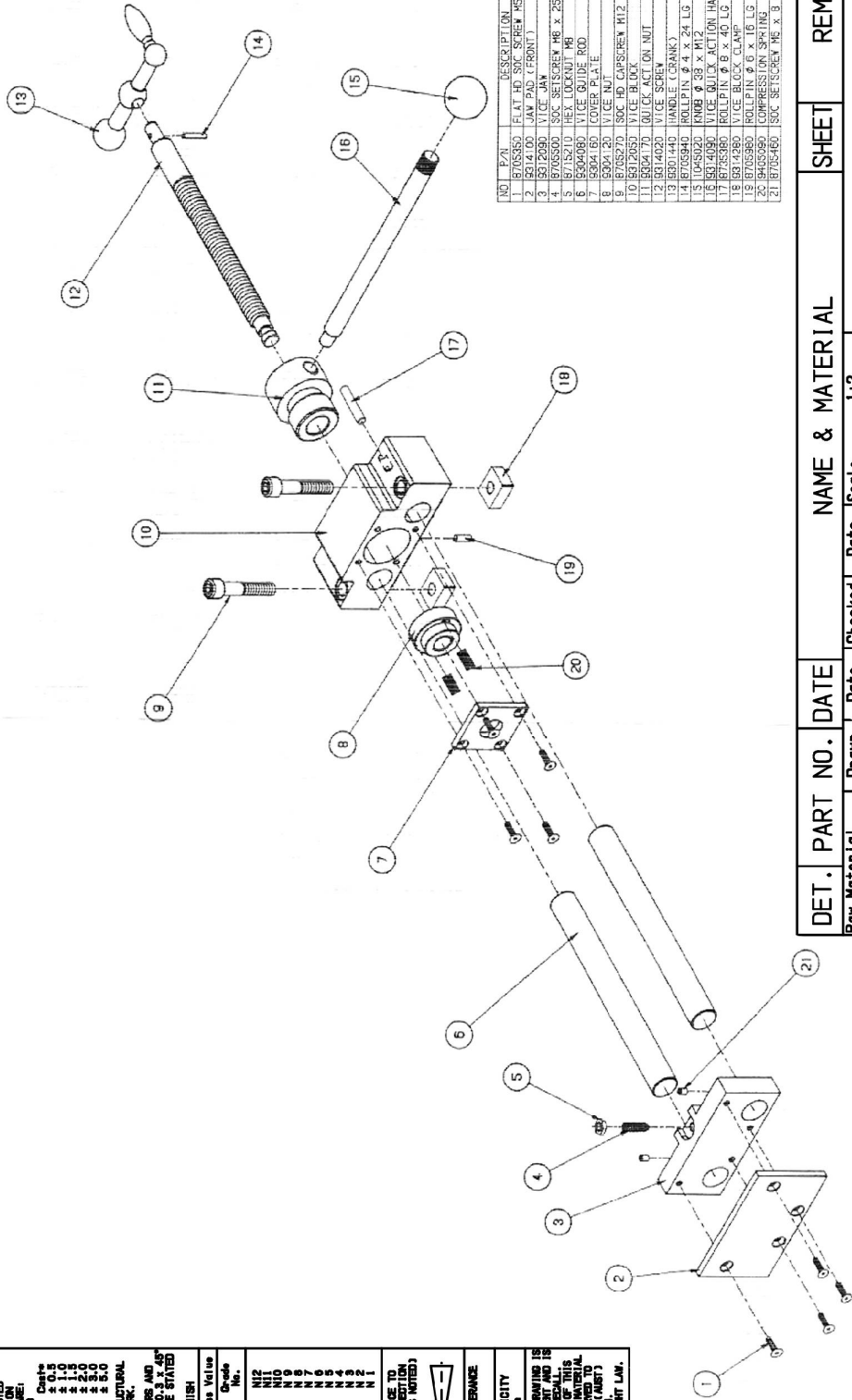

NO.	PART NO.	DESCRIPTION	QTY.
1	8705580	FLAT W. SCREW MS x 16 LG	6
2	5314100	JAW PAD (FRONT)	1
3	5312000	VICE JAW	1
4	8705500	SOC SETSCREW M8 x 25 HALFPOG	1
5	8715210	HEX LOCKNUT M8	1
6	5304080	VICE GUIDE ROD	2
7	5304100	COVER PLATE	1
8	8705570	SLIDE W. SCREW M12 x 60 LG	1
9	5312030	VICE LINK	2
10	5304170	BUCK ACTION NUT	1
11	5314400	VICE SCREW	1
12	5314420	HANDLE (CRANK)	1
13	8705540	ROLL PIN 4 x 24 LG	1
14	8705520	KNOB 28 x M12	1
15	8714030	VICE BUCK ACTION HANDLE	1
16	8714040	ROLL PIN 4 x 24 LG	1
17	8705580	ROLL PIN 4 x 24 LG	1
18	8705580	ROLL PIN 4 x 24 LG	1
19	8705580	ROLL PIN 4 x 24 LG	1
20	8705580	ROLL PIN 4 x 24 LG	1
21	8705580	ROLL PIN 4 x 24 LG	1

DET. PART NO.	DATE	NAME & MATERIAL	SHEET	REMARK
Raw Material AS LISTED	Drawn J.L	Scale 1:1		
Project No.	Date 22/08/06	Sub Assembly		
Mat/Spec. AS LISTED	Checked	Layout No.		
	Per Unit 1			
Title BROBO STANDARD MANUAL VICE ASSEMBLY		Drg No. 9311060		
		Det. No.		
		Revision		



CADKEY A4

CHAPTER 5 - Adjustments for the Saw Unit

5.1 Changing the Blade

To replace a worn saw blade:

	<p><u>DANGER – ELECTROCUTION</u> <i>Make certain that the power to the manual saw is turned off before proceeding with changing the saw blade.</i></p>
---	---

- i) Disengage the linkage arm that is between the guard linkage system and pivot block (at the pivot block by compressing the spring and moving the bolt through the slot).
- ii) Slide the saw guard up as far as possible (as if it was opening during a cutting cycle) to gain access to the spindle nose.
- iii) Loosen the spindle screws (LH thread), using the 14mm hexagonal wrench provided, and remove the counter plate. To loosen the spindle screw, insert the wrench (short end) into the socket head cap screw and firmly knock the wrench with the palm of your hands until the screw is loosened. If this method fails to free the screw, place a piece of timber under the blade of the machine, and loosen (or tighten) the screw while holding the saw head of the machine down (blade against the timber).
- iv) Remove the worn saw blade away from the spindle hub. Using a soft brush, clean the face of the spindle, counter plate and mounting faces of the blade of any dirt or swarf that was trapped by the previous cutting cycles.
- v) Place the old saw blade into the new blade packaging and disposed of it safely. Carefully mount the new blade onto the spindle hub, ensuring that the blade is rotating into and towards the back fence, and replace the counter plate utilising the drive pins as guides as it passes through the pinholes on the blade.
- vi) Rotate blade back against the drive pins in a **counter-clockwise** and finger tighten the spindle screw.
- vii) Firmly retighten the spindle screws, ensuring that the saw blade spins uniformly and aligned parallel with the safety guard.
- viii) Lower the outer guards and make certain the pin of the linkage arm is re-engaged with the track on the inner guard and reconnect the guard linkage.
- ix) The new blade is ready for use. To check that the blade is performing correctly, carry out a sample cut on a piece of off-cut.
- x) If optional devices are supplied, mount the stock support and rollers on either side of the clamping table. Normally stock should feed from **left to right**, but it can be feed from the **right to left**, if required.

5.2 Adjusting the Cutting Angle

The back jaw wear plates on the **BW S315/S350/S400 Series Metal Cutting Saw** are typically fitted in the following manner. For angular cutting, the wear plates should be repositioned to provide the maximum support on one side and clearance on the other (*Figure 11*).

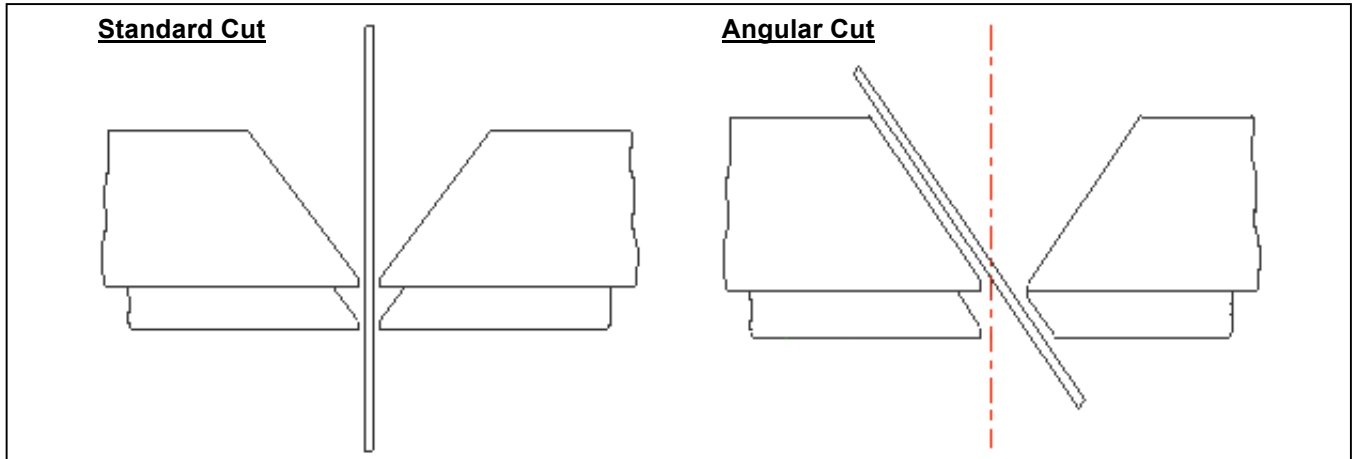

Figure 11. Angular Cut Positions

- i) To adjust the angle of the cutting surface, loosen the socket head screws shown in *Figure 10*, **located on the back jaw face that clamps the table**, using the hexagonal wrench provided.
- ii) Fine-tune the angle required. The shot-pins have positive locations at 90° and 45° right and left. Adjust the angle on the back fence to suit.
- iii) Re-tighten all the previously loosen socket head screws. The saw is now ready for use.

5.3 Cutting and Feeding Speeds

As previously highlights, the rate of feed largely affects the quality of the final cut. As such, the blade life is also dependent on the feed at which it is cutting the sample material - in particular, the type of material and also the cross sectional dimensions. Thus, to extend the life of the blade, maintain a firm and steady pressure whilst allowing the blade teeth to cut at an optimum rate. **Do not force the blade through the material!** This could cause numerous problems including breaking the blade teeth, jamming the blade with the cutting part or fracturing the blade spindle.

The cutting action also generates a large amount of heat within the cutting sample due to frictional contact. Should this heat affect the material you are cutting in any way, the heat should be dissipated using the coolant system.

5.4 Refilling the Lubricator

To refill the lubricator bowl, twist the bowl anti-clockwise and slide it down to detach it from the lubricator unit (There is no need to disconnect the air supply to the unit). The unit can now be refilled to the line positioned near the top of the bowl, which is approximately 10 millimetres from the top edge of the bowl. **Do not fill the bowl above this line**, as the lubricator unit will not function properly.

Replace the lubricator bowl in the reverse manner by sliding the bowl upwards, ensuring that the feed tube is located inside the bowl, and twist it clockwise to lock it into position.

5.5 Adjusting the Brobolube Unit

When assembled, the Brobolube unit is a precise instrument that supplies an accurate quantity of lubricant directly to the saw blade before it contacts the work piece. There are 2 control variables available for the operator:

1) Air Flow (Volume) Delivery

Regulated with the tap (needle valve), this can be adjusted from initial, completely closed to fully open states. It is highly recommended that the upper end of the flow range be utilised to allow an adequate airflow to deposit and evenly distributed the lubricant onto the blade, while maintaining a fine lubricant mix. If the needle valve is not open sufficiently, the air to lubricant ratio may vary, and may result in a substandard distribution of lubricant to reach the blade teeth.

NOTE

- i) Although the lubricator is capable of delivering a much higher flow rate of lubricant, it is suggested that you do not increase the flow rate excessively because:
- No significant increase in blade life or lubricating efficiency will be achieved (confirmed by test results).
 - Excessive application of Brobolube will only result in a waste of fluid.
 - Excessive application will produce swarf that will be wet (oily) and harder to clean up than dry swarf produced from the correct supply of Brobolube.
- ii) The amount of Lubricant (when set correctly) delivered by the lubricator is not easily visible by the naked eye. If in doubt that lubricant is being delivered, first check to see if lubricator itself is delivering droplets at its sight glass. If still unsure whether lubricant is being delivered, disconnect the supply tubing to the tap (needle valve) and hold the tube against some blotting paper for a few seconds while the lubricator is operating.

5.5.1 Lubricating Oil Precautions - Health Hazard Information

The Brobolube lubricating fluid has no known adverse health effects. "Brobolube" is non-toxic, odourless, non-flammable below approximately 350°C, and non-corrosive, although it may affect some types of rubber. There are no traces of sulphur, chlorine, phenol or nitrates found in Brobolube. When comes into contact with skin, the oil may be removed by wiping away the excess, then washing the contaminated area with detergent and water. If the oil is utilised at high temperatures, appropriate protective apparel should be worn as the oil could cause burns to skin or eyes. ***If splashed by hot oil, immediately run cold water over the burn area and apply first aid burn treatment.***

If the Brobolube delivery line breaks or becomes disconnected during operation, ensure that the air supply to the system is disconnected before repairing the problem.

It is recommended that footwear with anti-slip soles be worn at all times. Any spills will result in potentially hazardous slippery surfaces and should be dealt with promptly to prevent physical injury resulting from falls. Do not use coarsely, combustible material like sawdust to soak up oil due to the potential risk of spontaneous combustion. Spilled oil should be transferred into non-porous containers of suitable strength. Any remaining oil should be cleaned up with sand or other non-combustible, absorbent material. Place the sand and oil mixture into containers and disposed of by an EPA approved landfill or alternatively, by a suitable non-polluting method.

In addition, ***rags soaked in oil should not be burned. Do not pour oil down the drain***, which would ultimately contaminate the water supply and pollute the environment.

For fire fighting purposes, either use CO², dry chemical or foam retardant to extinguish the flames.

CHAPTER 6 – Maintenance and Selection of Consumables

6.1 Role of the Operator

The person operating and maintaining the **BW S315/S350/S400 Series Metal Cutting Saw** must familiarise themselves with these instructions for their own safety and that of the others, in addition to safeguarding the production of the machine. Responsibility must be taken by the user on the general maintenance and up keeping of the unit as specified in this chapter, with particular emphasis on:

- Check to ensure that other operators of the machine always aware of and comply with the relevant safety instructions and standards as specified in *Chapter 2 - Safety and Accident Prevention*. Therefore, check that the safety devices are operational and work perfectly and that personal safety requirements are complied with.
- Ensure that the working cycle is efficient and guarantees maximum productivity, inspect the:
 - Functions of the main components of the machine
 - Sharpness of the blade and coolant flow
 - Correct working parameters for the type of material being cut
- Verify that the quality of the cut meets the requirements and that the final product is free from any machining defects.

6.2 Maintenance Requirements

- All maintenance must be carried out with the power switched off and the machine in emergency stop condition.
- To guarantee for optimum operation, all spare parts must be **Brobo Group** originals.
- On completion of maintenance works, ensure that the replaced parts or any tools used have been removed from the machines before starting it up.
- Any behaviour not in accordance with the instructions for using the machine specified in this manual may create hazards and/or safety risks for the operator.
- Therefore, read and follow all the instructions for use and maintenance of the machine and those on the product itself.

6.3 General Maintenance of Functioning Components



The general maintenance operations that should be carried out regularly are as follows:

- i) Keep the vice clamps, overall machine and path of the cutting blade free of any offcuts, accumulated swarf and coolant using compressed air or preferably thread-free cloth.
- ii) Observe the oil level on the gearbox. The first oil change should be performed after the initial **25 hours of operation** and **300 hours of operation** thereafter. Use extreme pressure industrial gear oil - ISO VG 220 viscosity, conforming to AGMA 5EP, US Steel 224 or API GL-2 specifications to which 3% colloidal molybdenum disulphide has been added. Refilling point is situated in the handle bar mounting threaded hole. The required quantity to refill is approximately 1 litre for the S315/S350/400 gearboxes. Gearbox oil is available from BROBO GROUP Pty. Ltd. in 2 Litre packs (Part No. **9501090**).

- iii) Change coolant as required, or whenever the **coolant starts to get dirty or emits a stale odour**. The coolant compensation tank should be checked regularly. Coolant level would expect to naturally decrease over time due to natural evaporation. Use premium quality coolants such as *CoolTech 500* or *SlideTech 68*. Coolant is available from BROBO GROUP Pty. Ltd. in 2 litre packs (Part No. **9301570**).
- iv) Lubricate the saw head pivot shaft and rotary table regularly (**after every 40 hours of operation, or weekly**) with an *NLGI 2 extreme pressure grease, Shell Alvania No.1 grease* or equivalent.
- v) Clean the vice and lubricate any moving joints or sliding surfaces with good quality oil.
- vi) Clean the machine regularly and keep any unpainted surfaces lightly oiled to protect from rust and corrosion.
- vii) The air supply for the pneumatic air vices should be checked regularly such that it is free of any condensed water molecules and the filter should be drained frequently.
- viii) Ensure that the machine performs cuts perpendicular to the work surface. If not, contact Brobo Group engineering department.
- ix) Test that the blade is at right angles to the workpiece back fence. If not, contact Brobo Group engineering department.
- x) Check that the 0° notch on the fixed worktable is aligned with the gradation on the turntable. If not, adjust as described in *Section 5.2*.
- xi) Examine that the precision of the 15°, 30°, 45° left and right stops are correct and accurate. If they are not adjusted properly, proceed as described in *Section 5.2*.

CHAPTER 7 - Troubleshoot

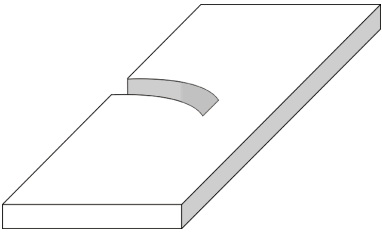
7.1 Troubleshooting For Blade and Cutting Problems

PROBLEM IDENTIFIED	DIAGNOSIS	SOLUTIONS
<p>Cuts produced are not at 90° and/or are not perpendicular</p> 	Head speed too low or too high	Reduce or increase head speed respectively.
	Blade with worn teeth	Replace with new blade, with reference to <i>Section 5.1 Changing the Blade</i> .
	Angularity of blade to workpiece back fence and vice clamps	Adjust the position of the blade so that it is at right angles to the workpiece back fence using the 0° notch as reference; set the stops at 45° left and right using the method described in <i>Section 5.2 Adjusting the Cutting Angle</i> .
	Blade not perpendicular to work surface	Adjust the blade using the appropriate screws such that it is perpendicular to the work surface.
<p>Frequent and/or excessive teeth breaking</p> 	Broken teeth	Check the hardness of the material being cut corresponds within the capabilities of the blade.
	Incorrect lubricant/coolant fluid	Check the water and oil mixture; check that the holes and/or hose are not blocked; direct the nozzles correctly; check that the lubricant/coolant fluid conforms to those specified in <i>Section 6.3 General Maintenance of Function Components</i> .
	Material too hard	Check the cutting speed, feed speed, blade type and parameters are correct for the particular application.
	Blade not worn in correctly	With a new blade, it is necessary to start cutting at <i>half feeding speed</i> . After a normalising period (cutting surface about 300cm ² for hard materials and 1000cm ² for softer materials), both cutting and feed speeds can be brought up to normal

Blade with incorrect and/or excessive fine tooth pitch

values.

As excessive pressure is exerted of the incorrect teeth profile, replace the blade with correct tooth pitch dimensions and profile.

Workpiece not clamped firmly in place

Any movement of the workpiece during the cutting process can cause broken teeth; check the vice clamps, clamping jaws and clamping pressure is satisfactory.

Excessive vibrations

Specimen vibrates in the vice; check that the vice clamps are position correctly and the clamping pressure are adequate.

Rapid teeth wear



Head speed too slow or too high

The blade/slide runs over the material without cutting it; increase or decrease head speed respectively.

Cutting pressure too high

Reduce cutting pressure

Insufficient coolant

Check the coolant level and clean piping and nozzles

Non-homogenous material being cut

The material present may not be homogenous either on the surface, such as oxides or sand present, or in sections, such as under-cooled inclusions. The variances in grain development cause the premature wearing of teeth and consequently, break as the result. Homogenise or clean these materials.

Broken blade



Head speed too high

Reduce head speed

Teeth in contact with material before commencing the cut

Always check the position of the blade before starting a initiating a new cut or job

Insufficient coolant

Check the coolant level and clean piping and nozzles

Excessive vibrations

Specimen vibrates in the vice; check that the vice clamps are position correctly and the clamping pressures

are adequate

7.2 General Troubleshooting

Below lists of some of the most commonly identified problems associated with the **BW S315/S350/S400 Series Metal Cutting Saw** and the recommended troubleshooting procedures to undertake to rectify the situations. If the solutions provided do not resolve the problem, or the problem identified differs from those listed, **immediately** contact Brobo Group engineering department.

PROBLEM IDENTIFIED	DIAGNOSIS	SOLUTIONS
Spindle motor will not rotate	Electrical power supply not connected	Ensure that the main power cable is plugged in and switched on. Check the phases, cables, plugs and sockets for loose connection. Also check that the motor connections are in place.
	Loose contactors	Verify that the contactors are not loose. If contacts are short-circuited, contact Brobo Group engineering department immediately
	Motor burnt out	Check that it has not burnt out, that it turns freely and there is no moisture in the main electrical unit. The winding can be rewound or replaced
	Blown fuses	Examine that the fuses are intact and fitted correctly, otherwise replace or tighten the fuse holders
Machine open slowly or not at all	Hydraulic oil level and pressure system	Check for any leaks present within the catchment unit. Top up the with coolant as recommended in <i>Section 6.3 General Maintenance of Functioning Components</i>
Coolant system not operational	Blocked coolant tubing	Check that it is not kinked, severed or blocked. Flush out any blockages



BROBO GROUP

A.C.N. 098 264 316
A.B.N. 342 098 264 316

BROBO WALDOWN (AUST) PTY. LTD.

65-67 Williams Rd, Dandenong, 3175
PO BOX 4274 Dandenong Sth, 3164
Victoria, AUSTRALIA.
Tel: 61 3 9794 8751
Fax: 61 3 9794 8792

Email: info@brobo.com.au
Website: www.brobo.com.au



APPENDIX - RISK/HAZARD ASSESSMENT

Hazard Type	Hazard Identification	Hazard Assessment	Hazard Management Strategies (Recommended for the Purchasing / Buyer / User)
Mechanical	Cutting/Severing	Low/Med	<ul style="list-style-type: none"> Keep machine correctly guarded and operational at all times. Keep hands clear of rotating blade when cutting.
	Entanglement	Low	<ul style="list-style-type: none"> Do not wear loose jewellery, clothing or items that might get caught in the saw. Always keep the work area free of unnecessary objects or tools.
	Puncturing	Low	<ul style="list-style-type: none"> Wear protective gloves when handling and /or changing the blades. Power source is to be isolated prior to opening electrical enclosures.
Electrical	Electrocution	Low	<ul style="list-style-type: none"> Remove the power supply when any maintenance and/or repairs are to be undertaken. Power source is to be isolated prior to opening electrical enclosures.
Thermal	Burn	Low	<ul style="list-style-type: none"> Under normal working conditions the gearbox can become hot thus, do not touch. Be careful when handling workpiece after cutting, as it might be very hot.
Noise	-	Low	<ul style="list-style-type: none"> Under no load testing, the noise level measured is below 85 db (A). If the noise level becomes too high during a cutting cycle, stop the process and inspect for problem, if any are present.
Substance	-	Low	<ul style="list-style-type: none"> Care must be taken as some coolants may be harmful or cause allergic reactions. Please read the labels carefully. Keep the work area clean and regularly remove excess coolant, oils and other impurities.
Hazardous Events	Unexpected Start Up	Low	<ul style="list-style-type: none"> During a power failure, turn the machine off. If problem persists, please contact Brobo Group engineering department.
	Failure of Control System	Low	<ul style="list-style-type: none"> If the ON/OFF switch fails, isolate the machine at the power source. Ensure that no fuses are blown and that all electrical circuitry are operating within normal parameters.
Additional Hazards	Operator Error	Low	<ul style="list-style-type: none"> Ensure blades, clamps and materials are correctly secured.
	Impact	Low	<ul style="list-style-type: none"> Wear safety glasses at all times during cutting cycle.

MACHINE TYPE: _____

SERIAL NO.: _____

RECEIVING COMPANY: _____ (SAFETY OFFICER)

Brobo Group Warranty

1.1 The supplier warrants that all goods supplied by it, shall be free from defects in materials and workmanship for a period of twenty four (24) months from the date of delivery to the Customer. ("the Warranty Period"), on the following terms and conditions.

1.2 The Customer shall promptly provide written particulars to the supplier on becoming aware of any defect in the goods during the Warranty Period, and shall provide the Supplier with all necessary access, facilities and information to enable the Supplier to ascertain or verify the nature and the cause of the defect and to carry out its obligations under this warranty.

1.3 The Supplier's obligation under this warranty is limited to repairs of the defect goods and the Supplier is under no obligation to replace the goods or refund the value of the goods to the Customer.

1.4 If the goods are, in the opinion of the Supplier, not defective or if any defect is attributable to any one or more of the following circumstances then the Supplier is under no obligation whatsoever to the Customer:

1.4.1 The use of the goods for a purpose other than that for which they were intended to be used;

1.4.2 The repair, modification or alteration of the goods by any person other than the Supplier;

1.4.3 Where the defect has arisen due to misuse, neglect or accident, howsoever arising;

1.4.4 Where the defect has arisen due to installation of the goods which were, in the reasonable opinion of the Supplier, incorrectly carried out

1.4.5 Where the goods have not been correctly stored or maintained

1.4.6 Where the defect has arisen due to normal wear and tear on the goods

1.5 The Supplier is under no obligation under this warranty where the Customer has failed to observe the terms of payment for the goods or any other obligation imposed by the terms and conditions of this warranty.

1.6 In the event that the Supplier is supplying goods, which have been manufactured by third parties, the Customer shall be entitled to the benefit of any Manufacturer's Warranty in respect of such goods. The Customer acknowledges that the Supplier accepts no responsibility whatsoever for any Manufacturer's Warranty or any claim howsoever arising from the use of the goods, whether singularly or in combination with other products.

1.7 The Supplier shall not be liable for any indirect or consequential losses or expenses suffered by the Customer, howsoever caused.

1.8 Except as specifically set out herein, or in writing by way of catalogue or pamphlet or otherwise provided by the Supplier to the Customer any term, representation, condition or warranty in respect of the quality, condition or description of the goods, whether implied by statute, common law, trade usage, custom or otherwise, is hereby expressly excluded.

This warranty is given by Brobo Group Pty Ltd, ABN: 42 098 264 316

Address: 65-67 Williams Rd, Dandenong, VIC 3175

Ph: 03 9794 8751 Fax: 03 9794 8792

Email: info@brobo.com.au

This warranty is provided in addition to other rights and remedies you have under law: Our goods come with guarantees which cannot be excluded under the Australian Consumer Law. You are entitled to replacement or refund for a major failure and to compensation for other reasonably foreseeable loss or damage. You are also entitled to have the goods repaired or replaced if the goods fail to be of acceptable quality and the failure does not amount to a major failure.