

AUTOMATIC

QA-6500

TOP LEVEL EFFICIENCY

FEATURES

- Fully automatic feed
- Superior 50mm \varnothing deep hole drilling - automatically cuts holes from 14mm \varnothing - 65mm \varnothing
- Boosts productivity
- Powerful two speed drill motor 400/750 RPM

SELF FEEDING & LOAD DETECTION

The feeding is controlled by an onboard microcomputer. The feed rate begins slowly and then increases to the appropriate speed for the cutter size and load conditions. The load detector clearly shows the amount of resistance on the cutter at anytime.

LIMIT SWITCH

When the drill has reached the top of its stroke, a limit switch stops the drill motor. There is also a limit switch at the bottom of drill stroke.



KEY FEATURES



Load Detector

- Feed rate controlled by onboard microcomputer. Load detector shows resistance on cutter at anytime.



DIMENSIONS

QA-6500
Unit : mm

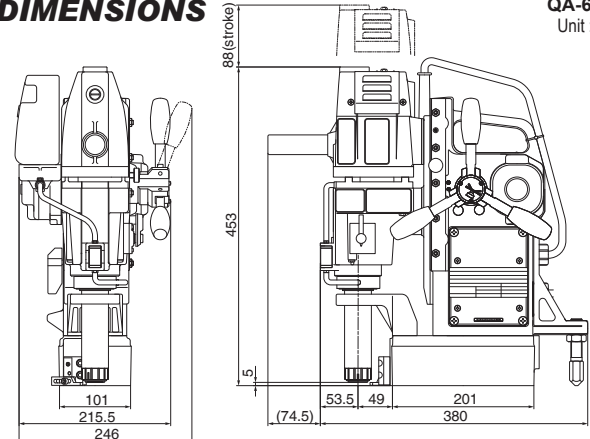

Two Speed Selection

- Speed can be changed to suit the type and size of cutter.

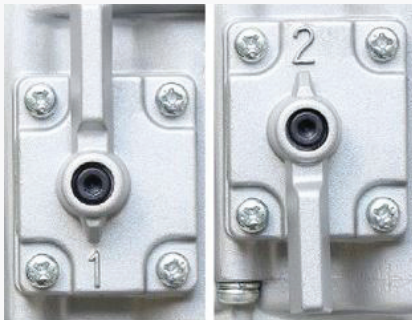

Improve Bearing Bracket

- Our precision bearing bracket aligns cutters precisely, which increases cutter life.



Other Optional Items

- **OZBROACH**
(High Speed Steel One-Touch Type 25mm, 50mm and 75mm depth of cut)
- **OZBROACH**
(Countersink - Product No. OT10-30CS)
* Only in Manual Feed Mode
- **JETBROACH**
(TCT Carbide Tipped Cutters 25mm, 35mm, 50 & 75mm depth of cut)



Always use Genuine Nitto Kohki Cutters

Model No.	Power Source	Rated Power Consumption	No Load Speed	Hole Diameter	Plate Thickness	Magnet Holding Power	Weight
QA-6500	220~240V AC 50/60HZ	1,010W	400/750rpm	14 - 65mm	9 - 75mm	1,000 kg/f	26kg

MACHINE TOOLS