

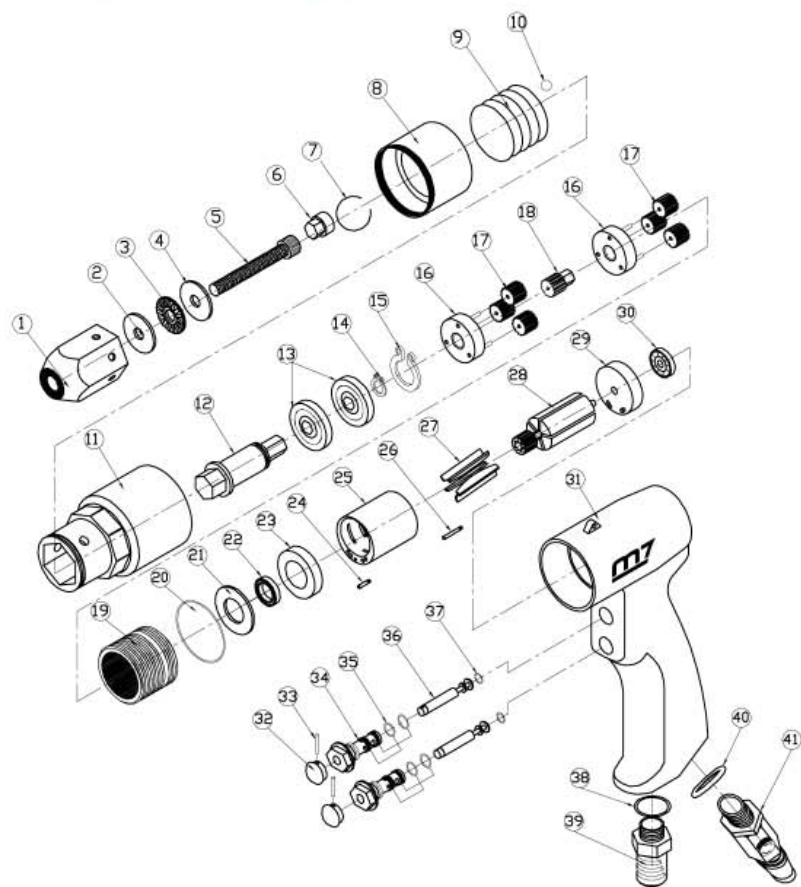

Air Rivet Nut Tool

Item No : PB-1308

● The consumable parts ▲ The replacement parts ★ The non-replacement parts



Part List

Item No : PB-1308



	NO.	PART NO.	DESCRIPTION	Q'TY
▲	1	---	Nose Piece	1
★	2	---	Washer	1
▲	3	---	Ball Bearing	1
★	4	---	Washer	1
●	5	---	Screw	1
●	6	---	Ole Driver Hexagon	1
★	7	PB-1308P07	C-Shape Ring	1
★	8	PB-1308P08	Bit Sleeve	1
★	9	PB-1308P09	Sleeve Spring	1
★	10	PB-1308T10	Bit Lock Ball (3 pcs)	1 SET
★	11	PB-1308P11	Nose Housing	1
▲	12	PB-1308P12	Bole Driver For Bearing	1
▲	13	PB-1308T13	Ball Bearing (2 pcs)	1 SET
★	14	PB-1308P14	C-Shape Ring	1
★	15	PB-1308P15	C-Shape Ring	1
▲	16	PB-1308T16	Gear Cage with Pin (2 pcs)	1 SET
▲	17	PB-1308T17	Planet Gear (6 pcs)	1 SET
▲	18	PB-1308P18	Transmission Planet Gear	1
▲	19	PB-1308P19	Internal Gear	1
●	20	PB-1308P20	O-Ring	1
★	21	PB-1308P21	Washer	1
▲	22	PB-1308P22	Ball Bearing	1

	NO.	PART NO.	DESCRIPTION	Q'TY
★	23	PB-1308P23	Front End Plate	1
★	24	PB-1308P24	Pin	1
★	25	PB-1308P25	Cylinder	1
★	26	PB-1308P26	Pin	1
●	27	PB-1308T27	Rotor Blade (5 pcs)	1 SET
▲	28	PB-1308P28	Rotor	1
★	29	PB-1308P29	Rear End Plate	1
▲	30	PB-1308P30	Ball Bearing	1
★	31	PB-1308P31	Motor Housing	1
★	32	PB-1308T32	Switch Lever (2 pcs)	1 SET
★	33	PB-1308T33	Pin (2 pcs)	1 SET
★	34	PB-1308T34	Air Inlet Switch (2 pcs)	1 SET
●	35	PB-1308T35	O-Ring (4 pcs)	1 SET
★	36	PB-1308T36	Air Valve (2 pcs)	1 SET
●	37	PB-1308T37	O-Ring (2 pcs)	1 SET
●	38	PB-1308P38	O-Ring	1
★	39	PB-1308P39	Silencer Case	1
●	40	PB-1308P40	O-Ring	1
★	41	PB-1308P41	Air Regulator	1
●		PB-1308T01	Nose Piece for M6 (1.2.3.4.5.6)	1 SET
●		PB-1308T02	Nose Piece for M8 (1.2.3.4.5.6)	1 SET
●		PB-1308T03	Trigger Ass'y (32.33.34.35.36.37)	1 SET