



KINCROME

PROFESSIONAL QUALITY TOOLS

WET & DRY WORKSHOP VAC

TWIN
MOTOR
SUCTION

2.5MT
SUCTION
HOSE

TROLLEY
WITH
ACCESSORY
STORAGE

TANK
DRAIN
HOSE

2X
1000W
MOTORS



KP705

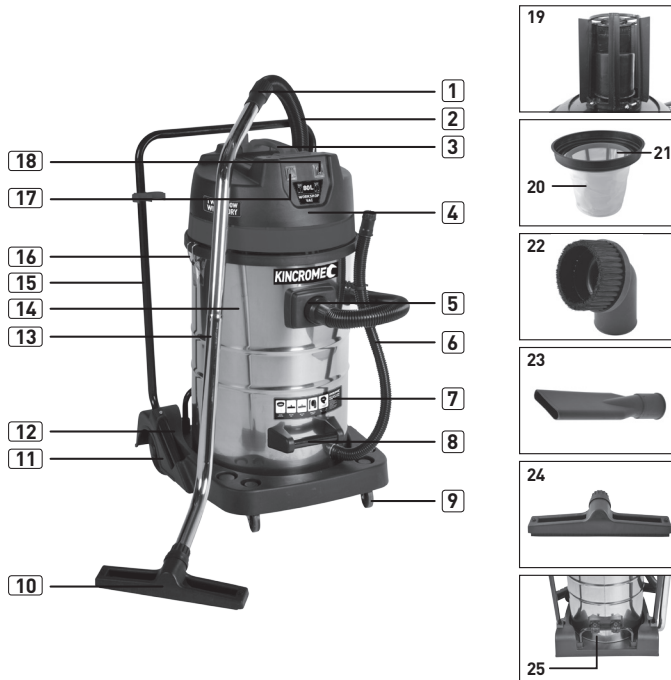

Table of Contents

Know Your Product 1
 Vacuum Safety Instructions 2
 Vacuum Assembly 4
 Vacuum Operation 5
 Trouble Shooting..... 8
 Warranty..... 9

Know your product

1. Wand Connection Coupling
2. Vacuum Hose
3. Carry Handle
4. Motor
5. Vacuum Hose Inlet Connector
6. Tank Drain Hose
7. Included Accessory Panel
8. Tank Tilt Handle
9. Swivel Castor Wheels
10. Dry Floor Tool
11. Rear Fixed Wheel
12. Trolley
13. 2Pce Extension Wand
14. Vacuum Tank
15. Trolley Handle
16. Tank Retention Clips
17. 2nd Motor On/Off Switch
18. 1st Motor On/Off Switch
19. Float Safety Valve
20. Cloth Filter
21. Cloth Filter Cage
22. Brush
23. Crevice Tool
24. Wet Floor Tool
25. Vacuum Tank Removal Clips



| | |
|------------------------------------|-------------------|
| Model No: | KP705 |
| Power: | 2 x 1000W |
| Input: | 220 - 240V ~ 50Hz |
| Hose Diameter: | 38mm |
| Hose Length: | 2.5mt |
| Tank Capacity Dry: | 80lt |
| Tank Capacity Liquid: | 43lt |
| Filter Type (Dry): | Cloth Filter |
| Filter Type (Wet): | Cloth Filter |
| Flow Rate: | 120L/S |
| Water Protection: | IPX4 |
| Net Weight: | 23.5 Kgs |

General Power Tools Safety Warnings



Save all warnings and instructions for future reference.

WARNING! Read all safety warnings and all instructions. Failure to follow the warnings and instructions may result in electric shock, fire and/or serious injury.

1) Electrical Safety

a) Power lead plugs must match the outlet.

Never modify the plug in any way. Do not use any adapter plugs with earthed (grounded) power tools. Unmodified plugs and matching outlets will reduce risk of electric shock.

b) Avoid body contact with earthed or grounded surfaces, such as pipes, radiators, ranges and refrigerators.

There is an increased risk of electric shock if your body is earthed or grounded.

c) Do not expose power tools to rain or wet conditions.

Water entering a power tool will increase the risk of electric shock.

d) Do not abuse the cord. Never use the cord for carrying, pulling or unplugging the power tool.

Keep cord away from heat, oil, sharp edges or moving parts. Damaged or entangled cords increase the risk of electric shock.

e) If operating a power tool in a damp location is unavoidable, use a residual current device (RCD) protected supply.

Use of an RCD reduces the risk of electric shock.

f) Do not operate powered products in explosive atmospheres, such as in the presence of flammable liquids, gases or dust.

Powered products create sparks which may ignite the dust or fumes.

g) Keep children and bystanders away while operating any powered products.

Distractions can cause you to lose control.

2) Service

Have your power tool serviced by a qualified repair person using only identical replacement parts.

This will ensure that the safety of the power tool is maintained.

3) Vacuum Safety Instructions

- The appliance may only be connected to alternating current. The voltage must correspond with the type plate on the appliance.
- This device is not intended for use by persons (including children) with reduced physical, sensory or mental abilities or lacking experience and/or knowledge, unless they are supervised by a person responsible for their safety or are instructed by these persons on the use of the device.
- The appliance may only be connected to alternating current. The voltage must correspond with the type plate on the appliance.
- This device is not intended for use by persons (including children) with reduced physical, sensory or mental abilities or lacking experience and/or knowledge, unless they are supervised by a person responsible for their safety or are instructed by these persons on the use of the device.
- Children should be supervised, to ensure that they do not play with the device.
- Keep packaging film away from children- risk of suffocation!
- Switch the appliance off after every use and prior to every cleaning/maintenance procedure.
- Risk of fire. Do not vacuum up any burning or glowing objects.
- The appliance may not be used in areas where a risk of explosion is present.
- Only use the appliance for its designated purpose. Any other types of use are at your own risk and are possibly dangerous.
- Never use the appliance when you are under the influence of medication, alcohol or drugs, if you are currently under medical care, or if you are tired.



4) Risk of Electric Shock

- Never touch the mains plug and the socket with wet hands.
- Do not pull the plug from the socket by pulling on the connecting cable.
- Check the power cord with mains plug for damage before every use. - If the power cord is damaged, please arrange immediately for the exchange by an authorized customer service or a skilled electrician.
- To avoid accidents due to electrical faults we recommend the use of sockets with a line-side current-limiting circuit breaker (max. 30 mA nominal tripping current).
- Check the appliance and the power cord regularly for any possible damage. Don't use damaged appliances.
- If the supply cord is damaged, it must be replaced by the manufacturer, its service agent or similarly qualified persons in order to avoid a hazard.

Caution

- Certain materials may produce explosive vapours or mixtures when agitated by the suction air!
- Never vacuum up the following materials:
 - a) Explosive or combustible gases, liquids and dust particles (reactive dust particles).
 - b) Reactive metal dust particles (such as aluminium, magnesium, zinc) in combination with highly alkaline or acidic detergents.
 - c) Undiluted, strong acids and alkalis.
 - d) Organic solvents (such as petrol, paint thinners, acetone, heating oil).

Note: In addition, these substances may cause the appliance materials to corrode.
- Make sure that the correct dust bag has been inserted securely in its holder before using the appliance. The wrong dust bag or incorrectly installed dust bags can cause damage to the appliance and cause the guarantee to become void.
- Do not vacuum up ashes, hot coals and the like, large fragments of glass and sharp objects.
- Don't vacuum up any toner dust, which is used in printers and copiers for example, because it is electrically conductive. In addition, it is possible that it will not be completely filtered out by the filter system of the wet/dry vacuum cleaner and can be released into the air via the exhaust fan.

5) Labels on Tool

The following symbols are shown on the tool:

 Your Vacuum Cleaner is double insulated; therefore no earth wire is required. Always check that the mains voltage corresponds to the voltage on the rating plate.

 The Cordless Screwdriver charger is intended for indoor use only.

 Read the instruction manual before use.

 Warning



Wet & Dry Workshop Vac User Instructions

KP705 - 80Lt Stainless Steel Tank .

1) Assembly

Remove all of the vacuum components from the box and dispose of all the packaging materials thoughtfully and as per your local council guidelines.

1. Connect the 2pce metal extension wand pieces (2) together by locating the lower handle locating rib into the upper handle rib receptor to create the vacuum wand. (fig 1)
2. Insert the lower vacuum hose connector (XX) into the vacuum hose inlet connector (10) and secure by pressing the lower vacuum hose connector (2) into the vacuum hose inlet connector (5) until the connection clicks.
3. Insert the upper vacuum hose connector onto the top end of the 2pce metal wand (2).
4. Locate either the wet or dry floor tool (10) or (24) onto the lower section of the 2pce metal wand (2).

2) Floor Tools (10) or (24)

The KP705 80lt Wet & Dry workshop Vacuum is supplied with two floor tools.

1. **Wet Floor Tool:** The wet floor tool (24) has a rubber squeegee on both the front and back edge of the floor tool to assist in vacuuming up liquids (fig 3).
2. **Dry Floor Tool:** The dry floor tool (10) has a soft brush on both the front and back edge of the floor tool to enable you to vacuum both hard surfaces such as concrete and softer surfaces such as lino/vinyl or carpets (fig 4).

3) Vacuum Filter (20)

The KP705 80lt Wet & Dry workshop Vacuum comes with a heavy duty cloth filter (20) that is suitable for both wet & dry vacuuming.



Cloth Filter (20)

- The cloth filter (20) is of heavy duty construction with a filter rating of 3 microns. This cloth filter can be used for all general vacuuming applications in both wet and dry applications. This cloth filter (20) can be continuously used for many years as it is a cleanable & washable accessory.
 - Regular cleaning of the filter is required to maintain optimal suction of the vacuum.
- Failure to clean the filters regularly can lead to damage of the vacuum and or poor performance of the product.
 - Premature failure of the product or poor performance of the vacuum is not covered by the manufacturer warranty and can be considered abuse of the tool.

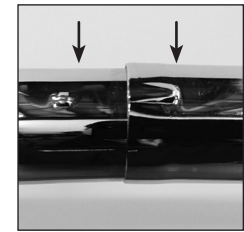

(fig 1)



(fig 2)



(fig 3)

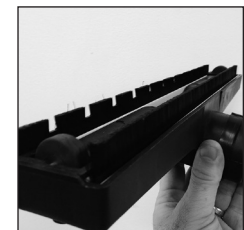

(fig 4)

Wet & Dry Workshop Vac User Instructions (cont.)

3) Installation of the Filters

1. Remove the motor head (4) from the vacuum tank (14) by releasing the tank retention clips (16) on the side of the vacuum.
2. Locate the cloth filter (20) onto the upper top ring of vacuum tank (14) (fig 5a). Once located ensure that the filter is pressed onto the vacuum tank (14) so the motor head (4) can be installed correctly.
3. Once you have installed the cloth filter (20) into your vacuum ensure that you insert the cloth filter cage (21) into the cloth filter (20) (fig 5b). The cloth filter cage (21) is designed to support the cloth filter (20) from collapsing during use due to the excessive suction power of the twin motors.

Once you have installed the cloth filter (20) and cloth filter cage (21) into the vacuum tank (14) replace the motor head (4) back onto of the vacuum tank (14), then locate and secure the tank retention clips (16) onto the motor head (4).

WARNING! This vacuum cleaner is **NOT** designed to be used as a water transferring device. The vacuum is intended to clean up general spills in & around the home or shed. **DO NOT** submerge the vacuum pipes or hoses directly into water when vacuuming.



(fig 5a)



(fig 5b)

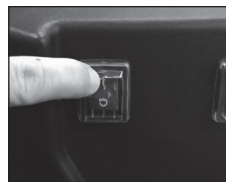

(fig 6a)

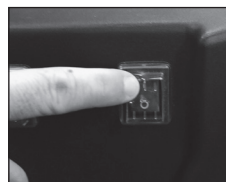

(fig 6b)



(fig 6c)



(fig 6d)

4) Operation

4a) Turning ON the vacuum

The KP705 workshop vacuum has 2 x 1000W motors for additional suction. Each 1000W motor can be switched on individually depending on how much suction is required to suit your application.

1. Plug the vacuum into your wall socket and turn the wall socket ON.
2. To turn ON the first motor of the vacuum press the ON/Off switch (17) to the "ON" "I" position. (fig 6a)
3. To turn ON the second motor of the vacuum press the ON/Off switch (18) to the "ON" "I" position. (fig 6b)

4b) Turning OFF the vacuum

4. To turn OFF the second motor of the vacuum press the ON/Off switch (18) to the "OFF" "O" position. (fig 6c)
5. To turn OFF the first motor of the vacuum press the ON/Off switch (17) to the "OFF" "O" position. (fig 6d)

4) Operation (cont.)

4c) Vacuuming

Note: When vacuuming dry materials it may be required to open the front or rear face of the wet or dry floor tool (10) or (24) to allow the larger debris (wood shavings, large dirt clumps etc.) to be sucked into the vacuum.

This can be achieved by tilting the wet or dry floor tool (10) or (24) up or down approximately 5-10° to create an opening between the wet or dry floor tool (10) or (24) front face and the floor. When pushing the wet or dry floor tool (10) or (24) forward push the extension wand (2) towards the ground slightly to open the front face of the wet or dry floor tool (10) or (24) and allow the debris to enter the vacuum. (fig 7)

When retracting the wet or dry floor tool (10) or (24) backwards lift the extension wand (2) towards the sky slightly to open the rear face of the wet or dry floor tool (10) or (24) and allow the debris to enter the vacuum. (fig 8)

4d) Vacuum Safety Float Valve (19)

Note: Your Wet & Dry vacuum is installed with a safety float valve (19) located within the filter basket. This float safety valve (19) is designed to stop any water from entering the motor head (4) if the vacuum tank (14) becomes full of a liquid. This safety float valve (19) will also activate if the vacuum falls over or overturns. Refer to the images (9) or (10) to identify yourself with the position of the safety float valve (19) in the event it has activated.

- Safety float valve in normal operation position (fig 9)
- Safety float valve in "activated" position. (fig 10)

The vacuum will not operate if the safety float valve (19) is in the activated position until it has been reset. To reset the safety float valve (19) turn off the vacuum & empty the vacuum tank (6) or upright the vacuum and turn off the vacuum and wait for 3-5 seconds. This should reset the safety float valve (19) and the vacuum can now be used again.

4e) Tank Drain Hose (6)

Your vacuum is fitted with a tank drain hose (6) (fig 11).

The tank drain hose (6) enables you to empty liquids from the vacuum tank (14) with ease. To empty the liquids from the vacuum tank (14) remove the end plug from the tank drain hose (6) (fig 12) and lower the hose to ground level to enable the liquid to drain from the tank (fig 14).

Note: Always follow your local council guidelines regarding the disposal of contaminated liquids.

5) Storage of the Wet & Dry Vacuum

WARNING! Ensure the tool is disconnected from the power supply before cleaning or maintaining the appliance.

- Always ensure that the vacuum is emptied of any debris prior to storage.
- Ensure that any liquids have been removed from the vacuum tank (14) and that the tank is completely dry prior to storage.
- Keep the machine out of reach of children, in a stable and safe position.
- Keep children and unauthorised personnel out of the storage room.

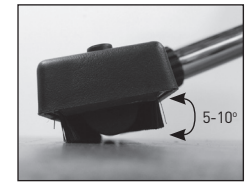

(fig 7)

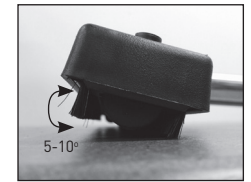

(fig 8)



(fig 9)

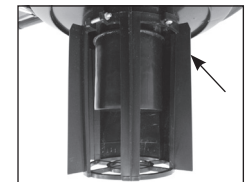

(fig 10)



(fig 11)



(fig 12)

6) Tank Tilt

The KP705 workshop vacuum is fitted with a tank tilt feature.

The tank tilt feature enables you to empty dust and debris from the vacuum tank (14) without needing to lift a full heavy tank.

1. To empty the vacuum tank (14) remove the vacuum motor head (4) and cloth filter (20) & cloth filter cage (21) from the vacuum tank (14) by releasing the tank retention clips (16), then remove the vacuum motor head (4), cloth filter (20) and cloth filter cage (21).
2. Using the tank tilt handle (8) tilt the vacuum tank (14) backwards towards the rear trolley handle (15) (fig 13) & (fig 14).
3. Tip the debris out of the vacuum tank (14) and dispose of it as per your council guidelines.



(fig 13)



(fig 14)

7) Tank Removal

The vacuum tank (14) can be removed from the trolley (12) to enable you to empty the debris collected in the vacuum tank (14) into a rubbish bin.

1. To remove the vacuum tank (14) from the trolley (12) move the two vacuum tank removal clips (25) into the upward position (fig 15).
2. Lift and remove the vacuum tank (14) and empty as required (fig 16).
3. Once emptied return the vacuum tank (14) onto the trolley (12) and move both vacuum tank removal clips (25) to the downward position. With both vacuum tank removal clips in the downward position the vacuum tank (14) is now secured to the trolley (12).

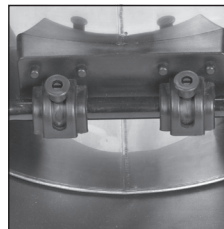

(fig 15)



(fig 16)

8) Maintenance of the Vacuum



WARNING! Ensure the tool is disconnected from the power supply before cleaning or maintaining the appliance.

- Regularly clean the vacuum filters to prolong the life of your product. Cleaning of the vacuum filters can be achieved by tapping/knocking the filter inside your garbage bin to release the dust/debris from the filter material and/or use compressed air to blow the dust debris out of the filter. (always ensure you are wearing the correct personal protection equipment PPE) when cleaning the vacuum filters. Also always consider your surroundings and other persons within your work area when cleaning your vacuum filters.
- Clean any dust or debris from around the vacuum filter basket (14) and on the underside of the motor head (4) on a regular basis to prevent this from being sucked into the vacuum motor.
- Immediately replace any damaged vacuum filters.
- Never attempt to lubricate any motor components of the vacuum.

8) Troubleshooting

| PROBLEM | CAUSES | SOLUTIONS |
|---|--|--|
| The Vacuum cleaner fails to start | Power cord is disconnected | Check the electric power supply line is connected to your wall socket correctly |
| | Vacuum is not switched ON | Check that the vacuum is turned on. To turn on the vacuum press either one or both ON/Off switches (17 & 18) to the "ON" "I" position. |
| | Electrical fault | Contact an authorised service centre. |
| The Vacuum cleaner does not vacuum efficiently | Vacuum tank full | Empty the Vacuum tank (14) |
| | Dirty / Clogged / Full filter | Clean the cloth filter (20) as described in Maintenance of your Vacuum. (Empty or replace filter bags if applicable to your vacuum model) |
| | The Vacuum safety float valve (19) has intervened due to the tank being full of a liquid. | Empty the Vacuum tank (14) |
| | Check that the vacuum hose (2), floor tools (10) or (24), extension wands (13) are not blocked | Ensure that the hose is not blocked by removing the hose assembly and inserting a broom handle through the hose to clear any obstructions. Do not force the broom handle to clear obstructions. |
| | Vacuum motor head (4) not assembled correctly | Reassemble the vacuum motor head (4) checking that it fits well onto the vacuum tank (14) and secure it in place with tank retention clips (16). |
| Substantial increase in motor revolutions and decrease in suction | Vacuum hose (2) blocked | Ensure that the vacuum hose (2) is not blocked by removing the hose assembly and inserting a broom handle through the hose to clear any obstructions. Do not force the broom handle to clear obstructions. |
| | The vacuum safety float valve (19) blocks the vacuum. A. This can happen when the vacuum tank (14) is full of liquid B. The vacuum has overturned. | A. Turn off the vacuum and empty the vacuum tank (14). B. Upright the vacuum and turn it off for approx. 3-5 seconds |



80LT WET & DRY WORKSHOP VAC



80LT WET & DRY WORKSHOP VAC

IMPORTANT!

If the vacuum cleaner still fails to operate correctly after you have carried out the above operations, or in the event of anomalies other than those described above, take the vacuum to an authorised service centre or place of purchase showing proof of purchase for assistance.

Spare Parts

- For a full list of available spare parts for this item visit the Kincrome website kincrome.com.au for reference.
- Type in the part number and then click on the documentation tab for a copy of the parts diagram and listing.

NOTE:

**12
MONTH
WARRANTY**

Warranty given by Kincrome Australia Pty Ltd of 3 Lakeview Drive, Caribbean Park, Scoresby, Victoria (Tel 1300 657 528). The applicable warranty period (12 months) commences on the date that the product is purchased. If this product has materials or workmanship defects (other than defects caused by abnormal or non warranted use) you can, at your cost, send the product to place of purchase, an authorised Kincrome service agent or one of Kincromes addresses for repair or replacement. Your rights under this warranty are in addition to any other rights you have under the Australian Consumer Law or other applicable laws. Our goods come with guarantees that cannot be excluded under the Australian Consumer Law. You are entitled to a replacement or refund for a major failure and compensation for any other reasonably foreseeable loss or damage. You are also entitled to have the goods repaired or replaced if the goods fail to be of acceptable quality and the failure does not amount to a major failure. For further details please visit www.kincrome.com.au or call us. Due to minor changes in design or manufacture, the product you purchase may sometimes differ from the one shown on the packaging.





www.kincrome.com.au

