

**COMPRESSOR PUMP
MODEL: K17-PUMP**

| | |
|--------------------|-----|
| CYLINDERS | 2 |
| STAGE | 1 |
| MAX PRESSURE (BAR) | 10 |
| MOTOR (KW) | 2.2 |
| FLYWHEEL (MM) | 320 |
| BELT SECTION | 1A |

DIMENSIONS

| | |
|------------------------------|-----------------|
| A | 132 mm |
| B | 100 mm |
| C | 180 mm |
| D | 260 mm |
| E | 320 mm |
| F (FROM BOTTOM OF FLY WHEEL) | 390 mm |
| H | 350 mm |
| WEIGHT | 12.5 KGS |

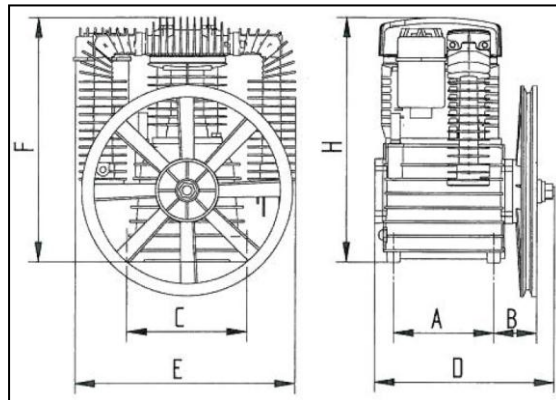

FEATURES

- **MADE IN ITALY**
- **DESIGNED FOR INDUSTRIAL USE**
- **CAST IRON CYLINDER BARRELS & STAINLESS STEEL VALVES**
- **ALLOY HEADS FOR IMPROVED COOLING**
- **BALANCED CRANKSHAFT FOR SMOOTHER, QUIETER OPERATION & LONGER LIFE**
- **LARGER DIAMETER FLYWHEELS DESIGNED TO DRAW COOL AIR OVER COMPRESSOR PUMP**
- **HIGH QUALITY INLET FILTER**

website – www.pilotair.com.au

email – sales@pilotair.com.au