

KINCROME [®]
PROFESSIONAL QUALITY TOOLS

PETROL POST HOLE DIGGER

INCLUDES
150MM
AUGER
BIT

HIGH
TORQUE
POWER
HEAD

ONE
PERSON
OPERATION

ALL
METAL
REDUCTION
DRIVE
GEARBOX



K16035
ED4 July 2019

Table of Contents

Know Your Product 1
 General Safety Instructions 2-3
 Description of symbols 4
 Assembly 5-6
 Operation 6-7
 Maintenance, Trouble Shooting & Warranty 7-10
 Parts Breakdown 10

Know Your Product

1. 51.7cc (1.7HP) 2 Stroke Engine
2. Recoil Starter
3. Fuel Tank
4. Fuel Cap
5. ON/OFF Switch
6. Throttle Lock-ON (start position)
7. Throttle Lock-OFF
8. Throttle
9. Fuel Primer Bulb
10. Drive Shaft
11. Shock Absorbing Safety Spring
12. Tungsten Carbide Tip
13. Cutting Face (High Carbon Steel)
14. Twin Vanes (Carbon Steel)
15. Locking Pin (with safety clasp)
16. Choke Lever
17. Handle
18. Fuel Mixing Bottle
19. Tool Kit

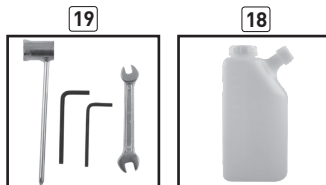
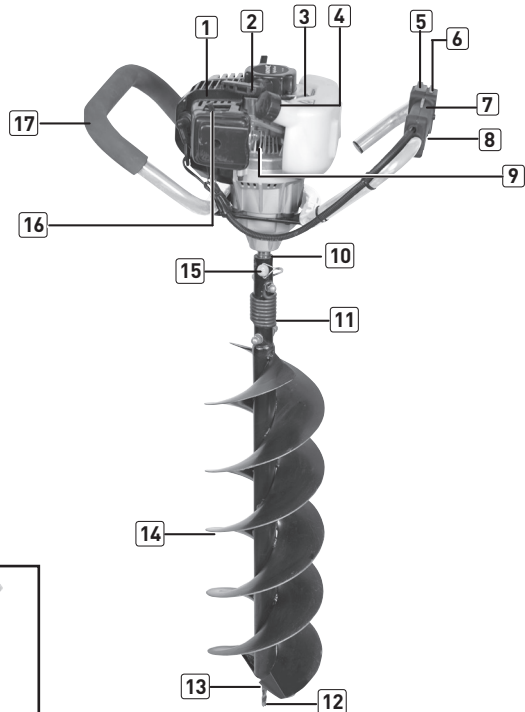

Model No:	K16035
Description:	Petrol Post Hole Digger
Engine Displacement	51.7cc
Rated Output Power:	1.3kw/1.7HP
Fuel tank (3) Capacity :	1.1L
Fuel Mixture:	Unleaded Petrol + 2-Stroke Oil
Fuel/Oil Mix Ratio:	30:1
Engine idle Speed:	3,000 RPM
Engine Max. Speed:	9,200 RPM
Auger Speed:	0-300 RPM
Engine Max Torque:	2.0 Nm
Gearbox Max Torque:	72 Nm
Sound Pressure Level (LPA):	95.7 dB(A)
Sound Pressure Level (LWA):	107.6 dB(A)
Weight:	13.5 kg

General Safety Warnings



Save all warnings and instructions for future reference.

WARNING! Read all safety warnings and all instructions. Failure to follow the warnings and instructions may result in electric shock, fire and/or serious injury.

1) Work Area

- a) Keep work area clean and well lit. Cluttered and dark areas can lead to accidents.
- b) Do not operate in explosive atmospheres, such as in the presence of flammable liquids, gases or dust. Post Hole Diggers create sparks which may ignite the dust or fumes.
- c) Keep children and bystanders away while operating a Post Hole Digger. Distractions can cause you to lose control.
- d) Always maintain a safe and secure position on level ground while operating this product. Beware of the conditions under foot. If working on a slope is unavoidable, always be sure of your footing.

2) Personal Safety

- a) Stay alert, watch what you are doing and use common sense when operating a Post Hole Digger. Do not use a Post Hole Digger while you are tired or under the influence of drugs, alcohol or medication. A moment of inattention while operating may result in serious personal injury.
- b) Use safety equipment. Always wear eye protection. Safety equipment such as dust mask, non-skid safety shoes, hard hat and hearing protection used for appropriate conditions will reduce personal injuries.
- c) Avoid accidental starting. Ensure the switch is in the OFF position.
- d) Remove any adjusting key or wrench before starting the Post Hole Digger. A wrench or a key left attached to a rotating part of the Post Hole Digger may result in personal injury.
- e) Do not overreach. Keep proper footing and balance at all times. This enables better control of the Post Hole Digger in unexpected situations.
- f) Dress properly. Do not wear loose clothing or jewellery. Keep your hair, clothing and gloves away from moving parts. Loose clothes, jewellery or long hair can be caught in moving parts.
- g) This Tool is not intended for the use by person (including children) with reduced physical, sensory or mental capabilities, or lack of experience and knowledge, unless they have been given supervision or instruction concerning use of the appliance by a person responsible for their safety.
- h) Children should be supervised to ensure they do not play with the Tool.

3) Post Hole Digger Safety Warnings

- a) Before using the Post Hole Digger the operator must be informed of the manufacturers safety instructions and instructions for use.
- b) The machine must only be operated by a trained person.
- c) Use the Post Hole Digger only in daylight or in good artificial light.
- d) Always start the Post Hole Digger carefully with your feet well away from the Auger bit.
- e) Do not leave the Post Hole Digger unattended when the engine is running.
- f) Do not use the Post Hole Digger barefoot or in open toed sandals. Always wear suitable clothing, gloves and safety shoes.
- g) Use the Post Hole Digger in soil only, do not use to bore holes in rocky ground.
- h) Do not bore holes in an area where there may be hidden gas and water pipes or electricity and other cables. Dial before you dig by calling 1100 or visting www.1100.com.au
- i) Ensure the Auger bit is attached to the gearbox output shaft securely using the supplied locking pin (15)
- j) Do not use a damaged or worn Auger Bit.
- k) Do not carry the Post Hole Digger with the engine running, the Auger bit should not rotate when the engine is idling.
- l) Keep hands and feet away from the rotating Auger Bit at all times.
- m) Always ensure that the engine is OFF and the spark plug cap is removed before making any adjustments.
- n) Before using your Post Hole Digger always visually inspect it to see if any parts are worn or damaged. Replace damaged parts before using the machine.

- o) Always operate the machine with two hands.
- p) **DO NOT** ever use the Petrol Post Hole Digger for any other purpose than digging post holes. It is designed for this use and any other use may cause an injury. Your Petrol Post Hole Digger is a precision piece of power equipment, not a toy. Exercise extreme caution at all times.

4) Post Hole Digger Use and Care

- a) Do not force the Post Hole Digger into the ground.
- b) Do not use the Post Hole Digger if the switch does not turn it **ON** and **OFF**. Any Post Hole Digger that cannot be controlled with the switch is dangerous and must be repaired.
- c) Disconnect the spark plug before making any adjustments, changing accessories, or storing. Such preventive safety measures reduce the risk of starting the Post Hole Digger accidentally.
- d) Store Post Hole Diggers out of the reach of children and do not allow persons unfamiliar with the Post Hole Digger or these instructions to operate the Post Hole Digger. Post Hole Diggers are dangerous in the hands of untrained users.
- e) Maintain Post Hole Diggers. Check for misalignment or binding of moving parts, breakage of parts and any other condition that may affect the Post Hole Digger's operation. If damaged, have the Post Hole Digger repaired before use. Many accidents are caused by poorly maintained Post Hole Diggers.
- f) Keep cutting tools sharp and clean. Properly maintained cutting tools with sharp cutting edges are less likely to bind and are easier to control.
- g) Always maintain a safe and secure position on level ground while operating this product. Beware of the conditions under foot. If working on a slope is unavoidable, always be sure of your footing.

5) Service











- a) Tool service must be performed only by qualified repair personnel.
- b) When servicing a tool, use only identical replacement parts. Use only authorized parts.
- c) Use only the lubricants specified by the manufacturer.

6) Petrol Engine Safety Warnings

- a) Petrol or diesel powered engines must never be used in unventilated or closed spaces. The exhaust fumes are highly dangerous and can cause "Carbon Monoxide Poisoning" which will cause drowsiness and death.
- b) The engine must not be run at speeds that exceed the maximum set speed. Operating an engine at excessive speeds increases the hazard of personal injury. Do not tamper with components, which may increase or decrease the governed speed.
- c) Never leave the engine running unattended near a building or near a canvas or plastic structure (e.g. Tents etc).
- d) Always use the correct fuel as stated in the user manual and on the rating plate.
- e) To prevent fire, always stop the engine when refuelling and never over fill the fuel tank (3). Always clean up spilt fuel immediately.
- f) Do not run the engine in or near an explosive atmosphere.
- g) Check the fuel system periodically for leaks. Seals and hoses should be checked for signs of deterioration or chafing. Check for loose or missing clamps, damaged fuel tank (3) or fuel cap (4). All defects should be corrected before further use.
- h) Do not allow the engine to run out of fuel while in use. The fuel contains the lubrication that protects the engine.
- i) Before transporting in a vehicle, drain all fuel to prevent leakage.
- j) Store the engine in a well-ventilated area with the fuel tank (3) empty.

7) Description of Symbols

The following symbols could be shown on the tool:

	Read the instruction manual before use.		Risk of Explosion
	Wear Ear Protection		Wear Eye Protection
	Warning		Wear Safety Gloves
	Wear sturdy non slip footwear		Do not smoke or bring any fire near the fuel
	Surface Hot to Touch		Risk of Fire



WARNING: Prior to operating the post hole digger it is recommended that you "DIAL BEFORE YOU DIG" by calling 1100 or visiting www.1100.com.au.

Dialling or visiting the website before you use the post hole digger could save your life or avoid costly repairs to underground services.



Petrol Post Hole Digger User Instructions

8) Preparing Engine For Starting

Fuel & Oil

1) The Petrol Post Hole Digger is powered by a 2 stroke engine which **MUST** be filled with regular unleaded fuel plus 2-stroke oil additive. Failing to add oil or incorrectly mixing the 2-stroke oil can result in poor engine performance, running problems and/or premature motor failure.

Caution: Any Petrol Post Hole Digger returned under Warranty which are found to have failed due to incorrect fuel mixture will be considered as a chargeable repair.

Mixture



WARNING: Always use the markings noted as, 30:1 fuel to oil mixing ratio located on the side of the fuel mixing bottle (18) when mixing fuel for the K16035 Petrol Post Hole Digger.

FUEL: UNLEADED	OIL	RATIO
1 Litre	33ml/1lt	30 : 1
5 Litre	165 ml/ 5lt	30 : 1

Mixing Fuel



Always handle fuel in a well ventilated area, outdoors, away from flames or sparks.

1) Fill the supplied Fuel Mixing Bottle (18) with unleaded fuel to the desired amount noted on the left side of the bottle.

Note: The bottle supplied with the Digger is only designed for short term use. Do not store fuel in this bottle for extended periods. Remove residual fuel from the supplied Fuel Mixing Bottle (18) after each use.

2) Using the respective line noted on the RH side of your desired amount, pour in 2 stroke oil (not supplied) until the mixture reaches the line just above the fuel amount already poured into the bottle (Fig A).

3) Screw fuel mixing bottle (18) cap on straight and tight, to prevent leaking.

4) Gently shake the container to mix the fuel and oil.

5) Wipe away any spilled fuel or oil and allow to evaporate before moving or transporting.

Filling Fuel Tank

1) Shut OFF engine and allow engine to completely cool before refilling.

2) Move to a well ventiaalted area, outdoors, away from flames and sparks.

3) Clean debris from the area around the fuel cap (4).

4) Remove the fuel cap (4) by unscrewing it from the fuel tank (3).

5) Carefully add fuel without spilling. Use a funnel (not provided) if required.

6) Immediately re-fit the fuel cap (4) and tighten. Wipe OFF any spilled fuel and allow to dry/evaporate before starting engine.

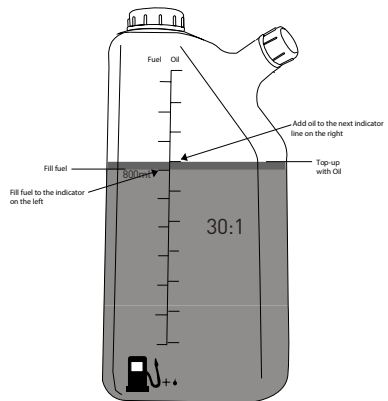

(Fig A)

9) General Operation Information

1) The clutch will transfer maximum power after about two hours of normal operation. During this break-in period clutch slippage may occur. The clutch should be kept free of oil and other moisture for efficient operation.

2) Drill holes without placing excessive body weight on the unit. The Auger operates most efficiently with a shaving action created by the weight of the unit itself.

3) Never run engine indoors. Exhaust fumes are deadly.

4) Do not use Post Hole Digger in ice.

10) Assembly

Attaching a Digger to the Drive shaft

- 1) Detach the clasp from the locking pin (15) and remove from the drive shaft (10) (Fig1).
- 2) Align the hole located at the top of the Auger Bit's connection socket with the hole in the drive shaft (10).
- 3) Insert Locking Pin (15) through the Auger Bit and Drive Shaft (10) until fully seated.
- 4) Secure by swinging the Locking Pin's (15) safety clasp around the Auger Bits connection socket, then expand the safety clasp so it can be locked over the protruding Locking Pin end (Fig 2).
- 5) The Auger should now be securely fastened to the Petrol Post Hole Digger and ready for use.

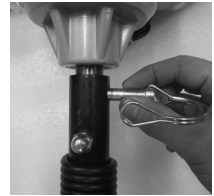

Fig 1



Fig 2

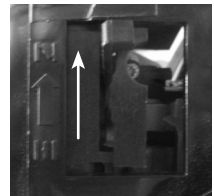

Fig 3

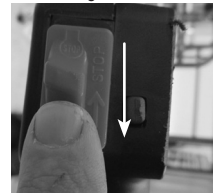

Fig 4



Fig 5

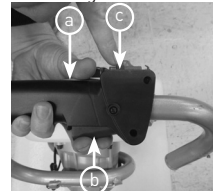

Fig 6

11) Operation



DO NOT ever place hands or feet near Auger Bit while motor is operating. To do so may result in crushed or amputated fingers, toes or worse, you may lose an arm or foot.

DO NOT straddle the handle/s of the Petrol Post Hole Digger when using it. A slip in any position could result in a serious injury.



DO NOT ever leave the Petrol Post Hole Digger unattended with the engine running. Shut OFF the engine if you are leaving the Petrol Post Hole Digger, even for a short period of time. Someone could accidentally activate the Petrol Post Hole Digger and be injured.

DO NOT use starting fluid.

DO NOT spray flammable liquids or vapours into air cleaner, carburetor or spark plug chamber.

DO NOT remove the spark plug and pull on starter rope. Flammable fuel can spray out and ignite from a spark from the spark plug.

Cold Engine Start

Starting the engine for first time or after engine has cooled down for refueling the post hole digger.

- 1) Move Choke Lever (16) to the "I" position (Fig 3).
- 2) Push ON/OFF switch (5) to the ON position (Fig 4).
- 3) Press the Fuel Primer Bulb (9) 5 to 10 times or 3 to 4 times after fuel is present in the Fuel Primer Bulb (9) (Fig 5).

Note: Choke Lever (16) must be in the "I" position when using the Fuel Primer Bulb (9).

4) With right hand push down on the Throttle Lock-Off (7) (Fig 6. a), squeeze the Throttle (8) (Fig 6.b), then with your left hand push and hold the Throttle Lock-On (6) (Fig 6.c) button then release the Throttle (8) (Fig 6.b) and Throttle Lock-Off (7) (Fig 6a).

Note: This will lock the Throttle (8) partially on for starting.

5) Hold down the Petrol Post Hole Digger firmly with one hand. With the other hand grip the Recoil Starter (2) and pull slowly until resistance is felt indicating that the Recoil Starter is engaged. When resistance is felt, pull the cord sharply.

Note: Continue this procedure until the engine starts. When the engine has been successfully started and is running return the Choke Lever (16) to "O" OFF position.

6) Squeeze the Throttle Lock-Off (7) (Fig 6a) and then squeeze the Throttle (8) (Fig 6b), until the desired speed is achieved.

7) To stop the Auger Bit from rotating, briefly squeeze then release the Throttle (8).

Note: Run at full throttle when possible. Do not let the unit idle for extended periods of time.

8) To stop the engine, push the ON/OFF switch (5) (Fig 4) to the OFF position.

Hot Engine Start

1) Push ON/OFF Switch (5) to the ON position (Fig 7).

2) Move Choke Lever (16) to "I" (Fig 8).

3) With right hand push down on the Throttle Lock-Off (7) (Fig 9a), squeeze the Throttle (8) (Fig 9b), then with your left hand push and hold the Throttle Lock-On (9) (Fig 9c) button then release the Throttle (8) (Fig 9b) and throttle Lock-Off (7) (Fig 9a).

Note: This will lock the throttle (8) partially on for starting.

4) Hold down the Petrol Post Hole Digger firmly with one hand. With the other hand grip the Recoil Starter (2) and pull slowly until resistance is felt indicating that the recoil starter is engaged. When resistance is felt pull the cord sharply.

Note: Continue this procedure until the engine starts.

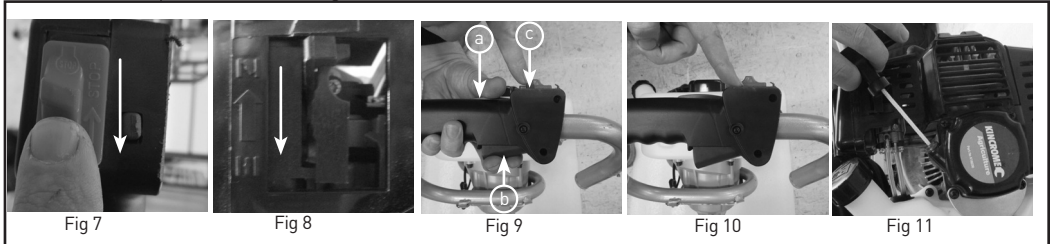

5) Squeeze the Throttle Lock-Off (7) (Fig 9a) and then squeeze the Throttle (8) (Fig 9b), until the desired speed is achieved.

6) To stop the Auger Bit from rotating, briefly squeeze then release the Throttle (8).

Note: Run at full throttle when possible. Do not let the unit idle for extended periods of time.

7) To stop the engine, push the ON/OFF Switch (5) to the OFF position (Fig. 10).

12) Maintenance

Post Hole Digger Maintenance

1) The gear box has 118 grams of grease installed by the factory. It is recommended that once a year the gear box be split and grease level checked. Add grease only if level of grease is below top of the gears. **DO NOT OVERFILL.**

Caution: It is recommended that this maintenance is performed by a qualified service agent.

2) For cold weather operation, store the unit in a cool environment. Transferring the unit from a warm to cold place can cause the build up of harmful condensation.

3) If Auger Bit performance decreases, turn the unit OFF. Carefully inspect the cutting edge of the Tungsten Carbide Tip (12) and cutting face (13) for any signs of wear. If blades show any of these signs, they need to be sharpened or replaced.

Cooling Fins



Never run the engine without the air cleaner properly installed. Added wear and engine failure may occur if air cleaner is not installed on the engine. Service the air cleaner every 3 months or after 20 hours of operation. Clean air filter daily in extremely dusty conditions.

Cooling fins, air inlets and linkages must be free from any debris before each use.

Air Filter

Steps for cleaning Air Filter:

1) Wash in warm water with mild soap until dirt and debris are removed. Press filter when washing, do not wring.

2) Rinse in warm water until soap and dirt are removed.

3) Dry filter by wrapping in a clean cloth and pressing filter until it is dry.

- 4) Apply Castrol Foam Air Filter Oil to the entire filter.
- 5) Remove excess oil.
- 6) Attach the filter and air cleaner cover to the engine.

Spark Plug

- 1) Check spark plug every 50 hours of operation.
- 2) Disconnect the spark plug cap, and clean any debris around the spark plug area.
- 3) Remove spark plug and replace if any of the following occur; pitted electrodes, burned electrodes, cracked porcelain, or deposits around electrodes.
- 4) After analysis, seat spark plug and tighten with a spark plug wrench (19) as follows.
 - Reinstall original spark plug, tighten additional 1/2 turn.
 - Install new spark plug, adjust spark plug gap to 0.7 - 0.8mm and tighten additional 1/8 - 1/4 turn.

Note: A loose spark plug may overheat and damage engine. Over tightening the spark plug may damage the cylinder head.

Carburetor

Note: Never tamper with factory settings of the carburetor.

13) Transporting

Transporting Your Earth Digger

- 1) Never transport engine inside an enclosed space or vehicle. Fuel or fuel vapours may ignite causing serious injury or death.
- 2) If fuel is present in the fuel tank (3), remove fuel into a certified fuel container. DO NOT siphon by mouth.
- 3) Run engine to use up fuel in the carburetor after fuel tank (3) has been emptied. Always run engine in a well ventilated area.
- 4) Wipe away any spilled fuel from engine and Post Hole Digger. Allow to dry.

14) Storage

Note: If your Post Hole Digger will not be used for more than one month, prepare it for long term storage.

- 1) Add fuel stabiliser according to manufactureres instructions.
- 2) Run engine for 10-15 minutes to ensure the stabilizer reaches the carburetor.
- 3) Remove the remainder of the fuel from the fuel tank (3) into a certified fuel container.
- 4) Remove auger from 2-stroke engine (1) and apply a thin layer of grease to the output shaft (10).
- 5) Store auger and power head/engine (1) in a vertical position.
- 6) Remove all debris from the auger and powerhead/engine (1) .

16) Troubleshooting

PROBLEM	POSSIBLE CAUSES	SOLUTIONS
Engine will not start.	Engine is switched OFF.	Push ON/OFF switch (5) to ON position.
	Spark plug wire has disconnected.	Connect spark plug wire to spark plug.
	Out of fuel.	Re-fuel the unit (30:1 ratio).
	Spark plug wet, faulty or improperly gapped.	Clean, replace or re-gap spark plug.
	Throttle control not held wide open.	Hold throttle (8) wide open when pulling the pull starter.
Old and Dirty Fuel	Fuel line not positioned in bottom of fuel tank (3).	Push fuel line down into fuel in the fuel tank (3).
Engine runs rough, floods during operation.	Dirty air filter.	Clean or replace air filter.
	Choke partially engaged.	Turn OFF choke (16).
	Carburetor out of adjustment.	Call Kincome Customer Service.
Engine is hard to start.	Old/dirty fuel.	Drain fuel and replace with fresh fuel.
	Spark plug wire loose.	Make sure spark plug wire is securely attached to spark plug.
	Dirty Carburetor.	Clean Carburetor, use fuel stabiliser and fresh fuel.
	Throttle (8) not held wide open.	Prime unit 3 more times, then hold throttle (8) wide open when pulling the pull starter.
Engine misses or lacks power.	Incorrect fuel mixture	Drain fuel & replace with fresh 30:1 fuel
	Clogged air filter.	Clean or replace.
	Carburetor out of adjustment or faulty.	Call Kincome Customer Service.
	Spark plug wet, faulty or improperly gapped.	Clean, replace or re-gap spark plug.
Engine runs, then stops.	Blocked fuel filter.	Clean or replace.
	Carburetor out of adjustment or faulty.	Call Kincome Customer Service.
Engine revs too high.	Carburetor out of adjustment.	Call Kincome Customer Service.
Auger turns at idle.	Idle speed too high.	Adjust idle speed lower.
	Broken clutch spring.	Call Kincome Customer Service.
Auger turns, but has no power.	Choke (16) has not been turned OFF.	Turn OFF the choke (16) after engine is warm.
	Carburetor out of adjustment.	Call Kincome Customer Service.
	Broken Gears/Gearbox.	Call Kincome Customer Service.
	Worn clutch shoes.	Replace clutch shoes and springs.
	Worn engine lower seal.	Call Kincome Customer Service.

Auger Jumps.	Twin Vanes (14) Damaged.	Replace with new Auger Bit.
Auger cuts slowly.	Dull cutting face (13).	Replace Auger, or have cutting face (13) sharpened.
	Damaged Tungsten Carbide Tip (12).	Replace Auger bit.

IMPORTANT!

If the Post Hole Digger still fails to operate correctly after you have carried out the above operations, or in the event of anomalies other than those described above, take the Post Hole Digger to an authorised service centre or place of purchase showing proof of purchase for assistance.

17) Spare Parts

- For a full list of available spare parts for this item visit the Kincrome website kincrome.com.au for reference.
- Type in the model number K16035 and then click on the Spare Parts attachment located in the DOWNLOADS area for a copy of the spare parts diagram and listing.

OFFICE CONTACT DETAILS



Phone: 1300 657 528



Email: enquiries@kincrome.com.au



Fax: 1300 556 005



Website: www.kincrome.com.au

18) Warranty

Warranty given by Kincrome Australia Pty Ltd of 3 Lakeview Drive, Caribbean Park, Scoresby, Victoria (Tel 1300 657 528). The applicable warranty period (12 months) commences on the date that the product is purchased. If this product has materials or workmanship defects (other than defects caused by abnormal or non warranted use) you can, at your cost, send the product to place of purchase, an authorised Kincrome service agent or one of Kincromes addresses for repair or replacement. Your rights under this warranty are in addition to any other rights you have under the Australian Consumer Law or other applicable laws. Our goods come with guarantees that cannot be excluded under the Australian Consumer Law. You are entitled to a replacement or refund for a major failure and compensation for any other reasonably foreseeable loss or damage. You are also entitled to have the goods repaired or replaced if the goods fail to be of acceptable quality and the failure does not amount to a major failure. For further details please visit www.kincrome.com.au or call us.

Due to minor changes in design or manufacture, the product you purchase may sometimes differ from the one shown on the packaging.

IMPORTANT! If the tool fails to operate correctly, call customer service on 1800 657 528 for advice on the best resolution for your situation. If a resolution cannot be achieved over the phone please take the tool and all related accessories to an authorised service centre or place of purchase showing proof of purchase for assistance.

Note: Warranty excludes consumable items such as cutting faces and tips.

KINCROME 
PROFESSIONAL QUALITY TOOLS

www.kincrome.com.au