

KINCROME

10T HYDRAULIC BODY REPAIR KIT

10T
RATED
CAPACITY

12
QUICK FIT
ACCESSORIES

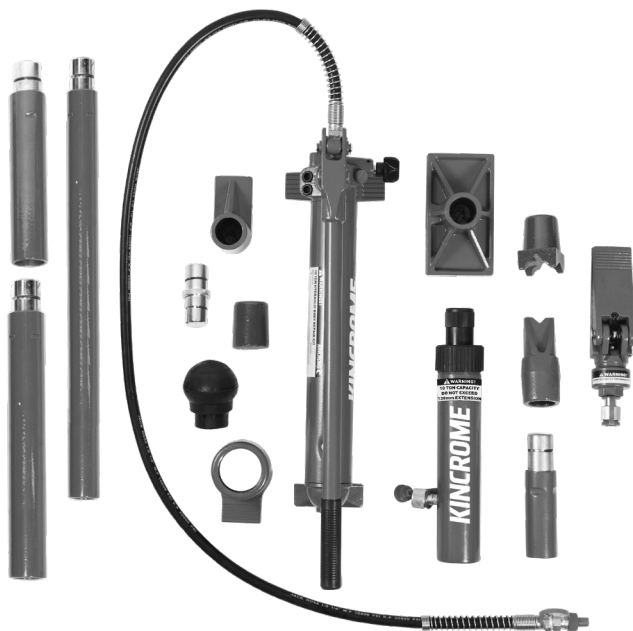

K15147



Caution: Do not allow persons to operate or assemble this jack until they have read this manual and developed a thorough understanding on how the jack works

TABLE OF CONTENTS

Specifications.....	2
Know Your Product.....	2
Important Safety Instructions.....	3-4
Unpacking and Assembling.....	4-5
Operation.....	5-6
Maintenance and Storage.....	6-7
Exploded Diagram.....	8
Troubleshooting.....	9
Warranty.....	9

SPECIFICATIONS

Model No:.....	K15147
Capacity:.....	10 Tonne
Minimum Ram Height:.....	322mm
Maximum Ram Height:.....	452mm
Ram Extension:.....	130mm
Weight:.....	32kg

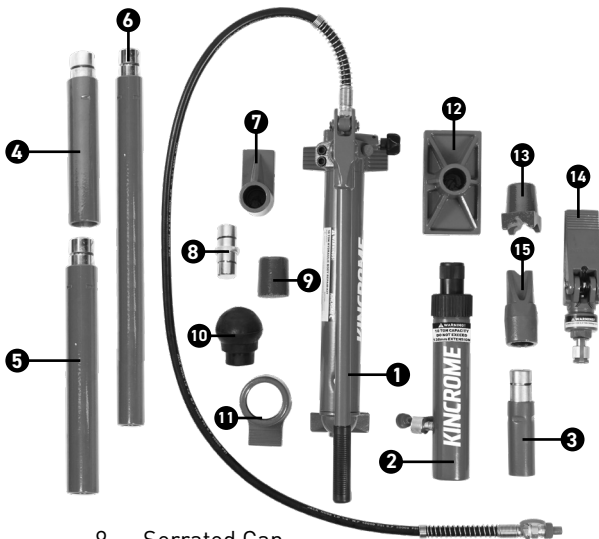

KNOW YOUR PRODUCT

- | | |
|-------------------------|----------------------|
| 1. Pump Assembly | 9. Serrated Cap |
| 2. Hydraulic Ram | 10. Rubber Head |
| 3. Extension Tube 110mm | 11. Ram Toe |
| 4. Extension Tube 265mm | 12. Flat Base |
| 5. Extension Tube 365mm | 13. Combination Head |
| 6. Extension Tube 520mm | 14. Spreader |
| 7. Plunger Toe | 15. Wedge Head |
| 8. Male Connector | |

General Safety Warnings



Save all warnings and instructions for future reference.

Read and understand the entire contents of this manual before attempting to use the body repair kit.

IMPORTANT SAFETY INSTRUCTIONS

This body repair kit is designed and intended for use by properly trained and experienced personnel only.

If you are not familiar with the proper and safe use of a body repair kit, do not use until proper training and knowledge has been obtained.

Failure to comply with all of these warnings may cause serious injury.

The use of a Body Repair Kits has inherent dangers to avoid risk of personal injury or property damage make sure you are fully aware of the operating instructions for this product. Do not exceed maximum rated capacity of this Body Repair Kit.

Preparing Work Area

Before using body repair kit, it is important to prepare work area properly. Follow this procedure each time the body repair kit is used to help prevent property damage and or serious injury.

1. Do not exceed the maximum load capacity of the ram.
2. Use only on hard level surfaces capable of sustaining the load.
3. Do not open oil filler screw unless ram is fully retracted and pressure is released.
4. Do not use as a vehicle lifting device, or as a vehicle support.
5. When extension tubes and/or offset attachments are used, the rated capacity is reduced by 50% for each tube or attachment connected.
6. Make sure all attachments are fully engaged before applying load or pressure.
7. If bowing or bending of ram or any attachment occurs during use, STOP, release pressure immediately and reconsider application. Application may not be compatible with product, a ram kit with a higher rated capacity may be required.
8. Do not over extend the ram, as it is possible to force the plunger out of the top of the cylinder.
9. When coupler valves are disconnected, insert dust cap to keep the oil lines clean.
10. Make sure the load is centrally applied to attachment or ram saddle. Do not load off centre.
11. Control the load. Always use a slow controlled release of system pressure. Failure to comply may result in serious injury or death. Avoid rapid releases of pressure.
12. Do not drop any heavy objects onto the hose and do not allow the hose to kink.
13. Allow clearance for the hose to avoid damage to the hose and couplers.
14. Keep equipment away from heat or fire, as this may damage or weaken the equipment.
15. Keep the floor around the body repair kit clean and free of scrap material, oil, and grease.
16. Use the right tool. Do not force a tool or attachment to do a job which it was not designed for.
17. Replace warning labels if they become obscured or removed.
18. Give your work undivided attention. Looking around, carrying on a conversation, and "horse-play" are careless acts that can result in serious injury.
19. Keep visitors a safe distance from the work area.
20. Use recommended genuine Kincrome accessories. Improper accessories may be hazardous.
21. Keep children and unauthorized persons away from the work area.

Personal Safety

1. Stay alert. Watch what you are doing and use common sense when operating the tool. Do not use the tool while tired or under the influence of drugs, alcohol, or medication. A moment of inattention while operating the tool increases the risk of injury to persons.
2. Dress properly. Do not wear loose clothing or jewellery. Contain long hair. Keep hair, clothing and gloves away from moving parts. Loose clothes, jewellery, or long hair increases the risk of injury to persons as a result of being caught in moving parts.

3. **Do not overreach. Keep proper footing and balance at all times.** Proper footing and balance enables better control of the tool in unexpected situations.
4. **Use safety equipment.** A dust mask, non-skid safety shoes and a hard hat must be used for the applicable conditions.
5. **Always wear eye protection.** Wear ANSI-approved safety goggles.
6. **Have a qualified person maintain the equipment in good condition. Keep it clean for best and safest performance.**
7. **If the equipment needs repairing and/or there are parts that need to be replaced, have it repaired by authorized technicians. Only use the replacement parts supplied by the manufacturer.**

UNPACKING AND ASSEMBLING

Unpacking

When unpacking the Body Repair Kit carefully inspect each component for damage that may have occurred during transit.

1. Check for any missing or damaged components and report these to the supplier for instructions.
2. Ensure all packaging materials are disposed of as per your local council guidelines.

Understanding Your Product

There are several different attachments which are provided, which are to be used with the Hydraulic Body Repair Kits, depending on the damage and the location of the vehicles damage.

- a. Flat Base (12):** Can be used to spread the load of the hydraulic ram. Connect to the female end of the hydraulic ram, using the male connector (8).
- b. Combination Head (13):** Can be used to align the pushing/pulling force of the hydraulic ram, when bearing against angled frames. This accessory attaches directly to the ram, or to extension tubes.
- c. Rubber Head (10) :** Can be used to pop out dents from sheet metal, such as vehicle doors and body panels. This accessory attaches directly to the ram, or to extension tubes.
- d. Wedge Head (15):** Can used to repair small dents in areas which are hard to reach and on angles. This accessory attaches directly to the ram, or to extension tubes.
- e. Male Connector (8):** Plugs into the female end of the hydraulic ram. This accessory attaches directly to the hydraulic ram or to the extension tubes.
- f. Ram Toe & Plunger Toe (11 & 7):** Can be used to push/pull the vehicles chassis. This accessory attaches directly to the hydraulic ram, to the extension tubes or used in place of the flat plate when space is limited.
- g. Serrated Cap (9):** Can be generally used for pushing during vehicle frame repairs. This accessory attaches directly to the hydraulic ram, or to the extension tubes.
- h. Extension Tubes (3, 4, 5 & 6):** Plug into one another for additional combinations to reach the desired length.
- i. Spreader (14):** Can be used in restricted spaces, when the hydraulic ram can't fit. This accessory attaches directly to the hose of the pump assembly (1).

Assembly

Note: Refer to page 7 for other additional assembly combinations.

1. Unscrew the end caps from the hydraulic hose w/coupling and hydraulic ram (Fig1). Retain end caps for use when storing the kit.
2. Align and connect the hydraulic hose w/coupling from the pump assembly (1) to the hydraulic ram then fasten the coupling clockwise to tighten securely (Fig 2). Do NOT overtighten.

Note: To provide maximum versatility a combination of pump accessories may be used. (Please refer to page 7 for combination options)

3. Fit the flat base plate (12) male connector (8) and desired extension tubes (3-6) with the hydraulic ram (Fig.3).
4. With the desired accessory fitted to the extension tube or hydraulic ram, it is now ready for use (Fig 4).

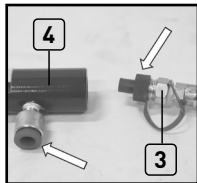

Fig.1

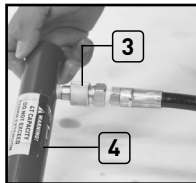

Fig.2

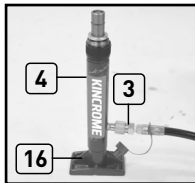

Fig.3

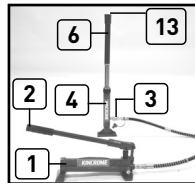

Fig.4

Bleeding / Venting Trapped Air

Note: Before use, the body repair kit may need to be purged. Some air may intrude in the hydraulic system due to movement during shipping. Air bubbles can become trapped inside the hydraulic system, preventing the body repair kit from functioning or reducing its efficiency, thereby reducing the efficiency.

Purge air from the system if efficiency drops.

1. Once the product is assembled, open the release valve by rotating it 1-1/2 turns, counter-clockwise (Fig 5).
2. Using the handle, rapidly pump continuously 15-20 full strokes to purge air from the hydraulic system (Fig 6).
3. Close the release valve clockwise until tight (DO NOT over-tighten) (Fig 7).
4. If the body repair kit does not feel like it is operating correctly, repeat the above process until all air has been purged from the system. If the problem continues contact Kincrome Customer Service.

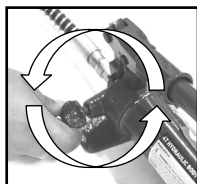

Fig.5

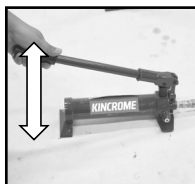

Fig.6

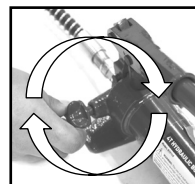

Fig.7

OPERATION

Caution: If any heavy weight squashes (comes into contact with) the hydraulic hose, replace the hose immediately!

(Spare parts are available)

Before first using Body Repair Kit carry out the following preparation:

Check oil level -

Caution: Do not let dirt get into the system, wipe the area clean around the filler plug, to prevent and dirt falling in.

- a. Release pressure and disconnect the hydraulic ram from the pump assembly (Fig 8).
- b. Place pump assembly horizontally on a flat and leveled surface (Fig 9).
- c. Remove filler plug (Fig 9) and add high quality hydraulic oil such as Kincromes' K12400 (HYDRAULIC JACK OIL 500ML) until the oil reaches the bottom of the filler plug (Fig 10).
- d. Reinstall the filler plug (Fig 9)
- e. Bleed system - refer to "Bleeding/Venting Trapped Air" on page 5.

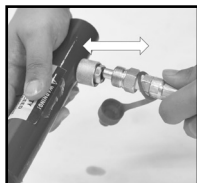

Fig.8



Fig.9

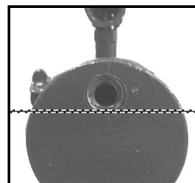

Fig.10

Raising the Ram Plunger (using the Handle)

WARNING!: Do not overload this Body Repair Kit. For the Maximum capacity, refer to the specification section for the max working limits **DO NOT** commence operation of ram until you are sure of total deflection requirement. Comprehensive planning for all operations is essential. Ensure the task undertaken falls within the capacity of the pump and any attachment.

Note: When adding further extensions to the hydraulic ram the maximum rated load is reduced.

1. Ensure the unit is assembled for the task at hand (Refer to page 7 for additional assembly combination options).
2. To operate the pump assembly (1), position it on a stable, leveled surface close to the damaged area/work area. Ensure the release valve is closed by turning it clockwise (Fig 11), then pump the handle to create pressure (Fig 12).
3. Turn the release valve counter clockwise to release the pressure (Fig 13).

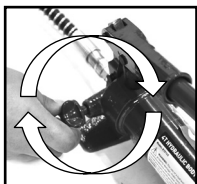

Fig.11



Fig.12



Fig.13

MAINTENANCE AND STORAGE

Care & Maintenance

WARNING!: Never use sandpaper or abrasive material on these surfaces!

WARNING!: DO NOT use brake fluid or any other improper fluid and avoid mixing different types of oil when adding hydraulic oil.

Caution: Prior to making any adjustments ensure the pressure is removed from the hydraulic system.

Note: These procedures are in addition to the regular checks and maintenance explained as part of the regular operation of the hydraulically operated tool.

1. **BEFORE EACH USE**, inspect the general condition of the tool. Check for:
 - a) loose hardware or housing.
 - b) misalignment or binding of moving parts.
 - c) cracked or broken parts, and damaged hoses.
 - d) any other condition that may affect its safe operation.
2. When not in use, store the equipment horizontally in a dry location with the hydraulic ram fully retracted.
3. Periodically check the pump assembly lever and hydraulic ram pistons for signs of rust or corrosion. Clean exposed areas with a clean oiled cloth.
4. Periodically lubricate the pivot point, axles and hinges with a light lubricating oil as needed, this will help to prevent rust and assure that pump assemblies move freely. Periodically lubricate the pivot point, axles and hinges with a light lubricating oil as needed.
5. With ram fully lowered, set unit in its normal, level position. Remove the oil filler screw to check the hydraulic oil level. If it is not adequate, add high quality hydraulic jack oil such as Kincromes K12400 (HYDRAULIC JACK OIL 500ML) as necessary.
6. To ensure best performance and longer equipment life, replace complete hydraulic oil at least once a year. With ram fully lowered, remove the oil filler screw and drain the oil into a suitable container. Ensure that no dirt gets into the system. Set the pump in its normal level position, fill with K12400 Kincrome Hydraulic Jack Oil, then replace the oil filler screw.

Note: Dispose of hydraulic oil in accordance with local regulations.

7. When equipment efficiency drops, purge air from the hydraulic system: turn the release counter-clockwise by 1-1/2 turns, with ram fully retracted and release valve open, pump the handle rapidly 10 to 20 times. It is recommended that an annual inspection be performed by a qualified technician.

Assembly Combinations

Vertical Push



Horizontal Push



Horizontal Push With Extension



Vertical Spread



Horizontal Spread



0.5T Spreader

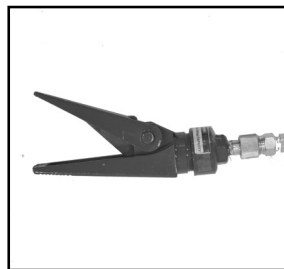





Caring For The Environment



When a tool is no longer usable it should not be disposed of with household waste, but in an environmentally friendly way. Please recycle where facilities exist. Check with your local council authority for recycling advice.



Recycling packaging reduces the need for landfill and raw materials. Reuse of recycled material decreases pollution in the environment. Please recycle packaging where facilities exist. Check with your local council authority for recycling advice.

Symbol	Property or statement
T/Ton	Weight in Tonne
	WARNING marking concerning Risk of Eye Injury. Wear ANSI-approved eye protection.
	WARNING marking concerning Risk of Hearing Loss. Wear hearing protection.
	WARNING marking concerning, Risk of Respiratory Injury. Wear NIOSH-approved dust mask/respirator
WARNING or 	Marking concerning/Risk of Injury.

Spare Parts

Part No.	No.	Description	Qty.	Size (mm)
K15147 - 13	1	Handle Assembly	1	φ24*560mm
K15147 - 14	2	Hydraulic Pump	1	560*146*144
K15146 - 16	3	Ram	1	322*φ55.5
K15146 - 17	4	Spreader	1	195*58*59
N/A	6	Blow Mold Case	1	700*290*160
K15146 - 6	7	Spreader Ram Toe	1	107*75*56
K15146 - 7	8	Spreader Plunger Tow	1	110*52*60
K15146 - 8	9	Wedge Head	1	115*φ48
K15146 - 9	10	90° V Base	1	80*56*56
K15146 - 10	11	Male Connector	1	100*φ33
K15146 - 11	12	Serrated Saddle	1	62*φ52
K15146 - 12	13	1	122*φ78	
K15146 - 5	14	Flat Base	1	155*90*63

Extension Tube Set		
K15146 - 1	05.1	φ41*110mm
K15146 - 2	05.2	φ41*265mm
K15146 - 3	05.3	φ41*365mm
K15146 - 4	05.4	φ41*520mm

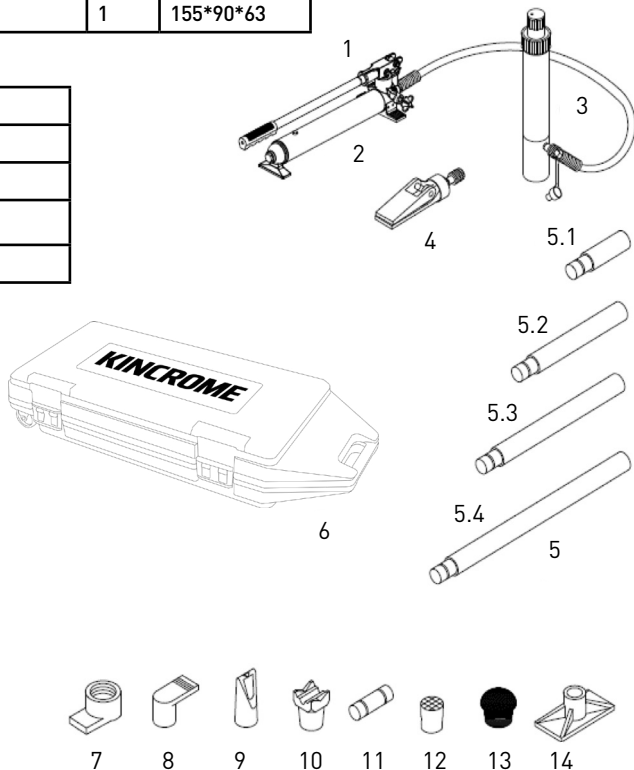

TROUBLESHOOTING

Symptom	Cause	Remedy
Pump assembly unit will not work	<ol style="list-style-type: none"> 1. Release valve is open. 2. Dirt on valve seats. 3. Worn seals. 	<ol style="list-style-type: none"> 1. Close the release valve. 2. Clean valve seats. 3. Replace seals.
Pump assembly unit will not produce pressure	<ol style="list-style-type: none"> 1. The reservoir could be overfilled or low on hydraulic fluid . 2. Leak in the hose, seals, or connections 3. Air trapped in the system. 	<ol style="list-style-type: none"> 1. Check the fluid level. Do not overfill. 2. Check the hose and replace if necessary. Make sure all connections are tight. 3. Open the release valve. Pump the handle a couple of full strokes. Close the release valve. 4. Contact Kincrome Customer Service
Pump assembly unit will not lower completely	<ol style="list-style-type: none"> 1. Air trapped in the system. 2. The reservoir could be overfilled or low on hydraulic fluid. 	<ol style="list-style-type: none"> 1. Open the release valve . Pump the handle a couple of full strokes. Close the release. 2. Check the fluid level is correct. Do not overfill.
Ram will not fully extend	Low on hydraulic fluid.	<ol style="list-style-type: none"> 1. Check that oil level is correct. 2. Check oil with ram fully retracted. 3. Add hydraulic fluid.
Fluid leaking from release valve	Worn O-ring.	Replace O-ring.
Fluid leaking from hose	Damaged hose.	Replace hose.
Fluid leaking around hydraulic ram piston	Worn seal or piston.	Please contact Kincrome customer service.

Office Contact Details:



Phone: 1300 657 528



Fax: 1300 556 005



Email: enquiries@kincrome.com.au



Website: www.kincrome.com.au

WARRANTY



Warranty given by Kincrome Australia Pty Ltd of 3 Lakeview Drive, Caribbean Park, Scoresby, Victoria (Tel 1300 657 528). The applicable warranty period (2 years) commences on the date that the product is purchased. If this product has materials or workmanship defects (other than defects caused by abnormal or non warranted use) you can, at your cost, send the product to place of purchase, an authorised Kincrome service agent or one of Kincromes addresses for repair or replacement. Your rights under this warranty are in addition to any other rights you have under the Australian Consumer Law or other applicable laws. Our goods come with guarantees that cannot be excluded under the Australian Consumer Law. You are entitled to a replacement or refund for a major failure and compensation for any other reasonably foreseeable loss or damage. You are also entitled to have the goods repaired or replaced if the goods fail to be of acceptable quality and the failure does not amount to a major failure. For further details please visit www.kincrome.com.au or call us. Due to minor changes in design or manufacture, the product you purchase may sometimes differ from the one shown on the packaging.

Distributed by Kincrome Tools and Equipment www.kincrome.com.au 3 Lakeview Drive Scoresby Victoria Phone: 1300 657 528

KINCROME

www.kincrome.com.au