



EL SERIES • PRODUCT INFORMATION

October 2018

HR90030

Diesel, Air and Water Spring Rewind Hose Reel

The EL Series HR90030 diesel, air and water spring rewind hose reel is a low pressure reel supplied standard with 12m rubber hose suitable for diesel transfer and air or water applications in commercial vehicle workshops, food processing, bottling plants, manufacturing facilities, pulp & paper manufacturing, minesite workshops, service vehicles and oil & gas industries. The hose reel drum is sturdy and practical with stiffening ribs and flanged edges for operator safety. The positive latching mechanism automatically locks the hose assembly at the desired length and the adjustable arms allow for floor, wall or ceiling mounting according to needs. The EL Series HR90030 diesel, air and water spring rewind hose reel from Alemlube will provide you with a reliable & cost effective means of storing and retrieving hose assemblies in your workshop.

**PRODUCT SPECIFICATIONS, FEATURES AND BENEFITS**

- Reinforced steel frame provides maximum strength & stability
- Maximum working pressure of 300psi (20bar)
- Includes 12m x 19mm ID rubber hose & hose stop
- 1.2m lead in hose supplied standard (not depicted)
- 1.5mm thick robust drum assembly with stiffening ribs & flange edges
- Reliable spring life and positive ratchet lock design ensures a long working life
- Can be mounted on the floor, wall or ceiling
- Durable long lasting powder coated finish protects against the incidence of rust
- 110° Swivel base available on request
- Extends hose life and reduces hose replacement costs
- Improves operator safety
- Improves factory or workshop productivity

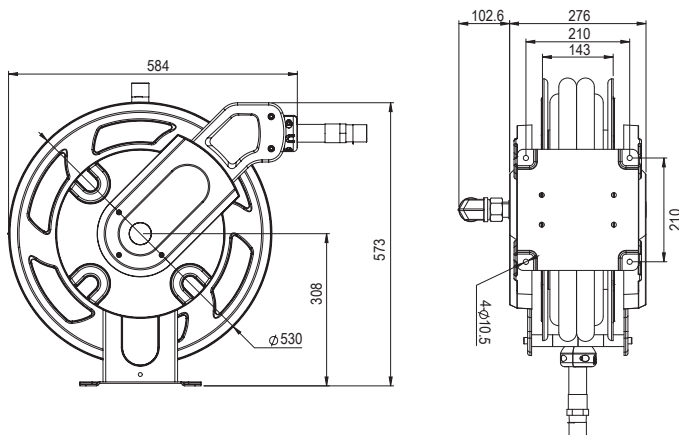
**ORDERING INFORMATION**

HR90030 Diesel, Air & Water Spring Rewind Hose Reel

