

HOLEMAKER PRO 52-MT2

**VERSATILE & MULTI-PURPOSE,
EUROPEAN MADE MACHINE**



Cutters
52mm



Twist Drills
23mm

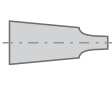

Spindle
MT2

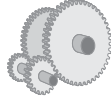

Gearbox
240rpm
480rpm

FEATURES

- Multi-purpose machine able to use Holemaker cutters, no. 2 Morse taper shank drills & reamers, as well as a drill chuck
- Industrial 2-speed gearbox
- Cast-iron motor housing
- Through spindle coolant system, with an external side mounted gravity feed coolant tank
- Left or right hand feed handle operation
- Unique semi-automatic gib adjustment system enables simple, fast and always correct fine tuning without any expert knowledge or experience
- Smart magnet technology to ensure sufficient magnetic adhesion
- Supplied in a blow mould plastic carry case
- Suitable for steel fabrication, engineering workshops & maintenance facilities where a heavy-duty versatile machine is highly beneficial

Part No.	HMPRO52-MT2
Capacity (Diameter)	52mm
Capacity (Depth)	52mm
Capacity (Twist Drills)	#2 Morse Taper 23mm
Motor Power	1100 Watt
Input Power	1200 Watt Single Phase 240V
Speed	2 Speed 240 / 480rpm
Weight	16.5kg
Magnetic Dead Lift	9,900Nm On 25mm Steel Plate
Stroke	165mm
Height (Min. / Max.)	456mm / 616mm

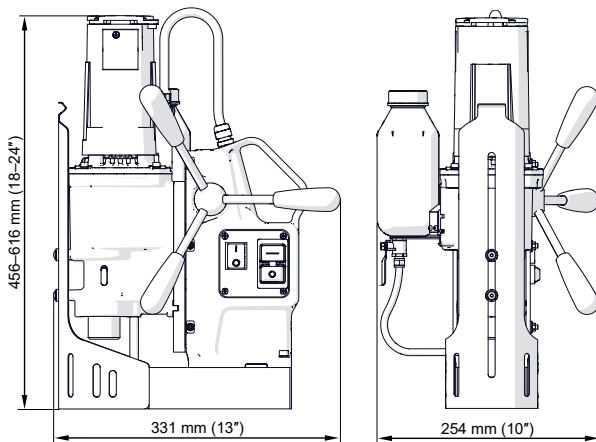

**EUROPEAN
MADE QUALITY**



VISIT WWW.ITMTOOLS.COM.AU

TO SEE OUR RANGE OF 6000+ INDUSTRIAL QUALITY TOOLS