

Suregrip Series

DM24 DIGITAL MIG TORCH



DM240A AIR COOLED MIG WELDING TORCH

Rating: 250A CO² 220A mixed gas EN60974-7 @ 60% duty cycle. 0.8 to 1.2mm wires

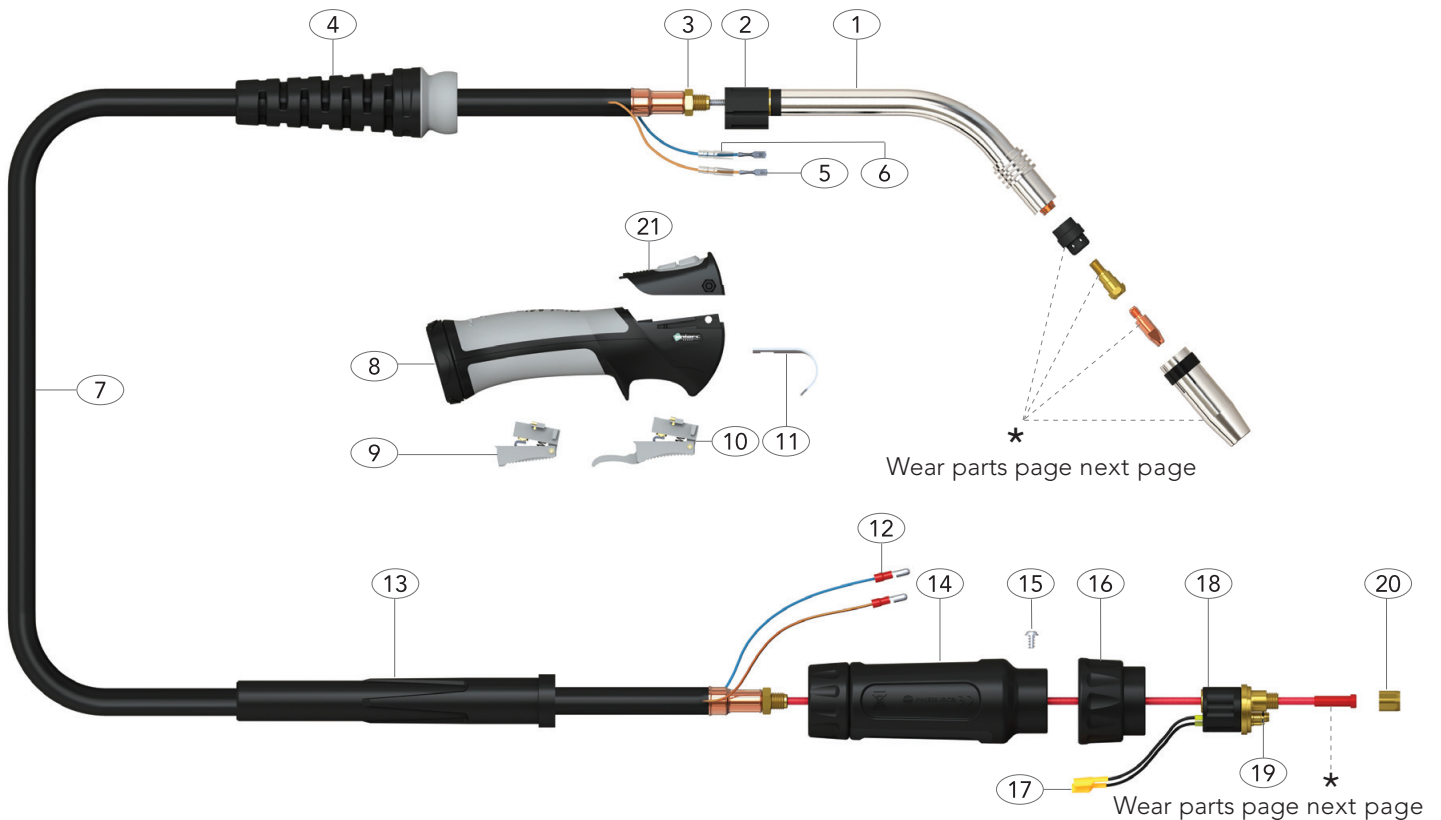

Torch Model	Description		
DM24 Digital Suregrip Ergo Torch Package	3 Mt DM2400-JDM2-MT1-30ER	4 Mt DM2400-JDM2-MT1-40ER	5 Mt DM2400-JDM2-MT1-50ER

Spare Parts		Part Number	Description		
1	SNK24	Swan Neck Assembly	11	UB2517	Hanger Hook
2	UG1515	Ergo Handle Location Body	12	UB1522	Cable Terminal Male
3	UB1505	Lock Nut	13	UPA2041	Cable Support
4	UG8015	Handle Cable Support C/W Ball Joint	14	UB1518	Gun Plug Housing C/W Nut
5	UB1521	Cable Terminal	15	UB1541	Gun Plug Screw
6	UB1521-C	Cable Terminal Cover	16	UB1519/S	Gun Plug Nut
7	UB2603-30	Hyperflex Cable Assembly x 3mt	17	UB1523	Gun Plug Terminal Female
	UB2603-40	Hyperflex Cable Assembly x 4mt	18	UC1528	Hybrid Gun Plug Body C/W Spring Pins
	UB2603-50	Hyperflex Cable Assembly x 5mt	19	UB1524	Gun Plug 'O' Ring
8	DM2514/KJ	Digi-Mig Handle Kit	20	UB1525	Liner Nut
9	DM2516	Standard Trigger Assembly	21	DM2	Digi-Mig Control Kit
10	DM2516L	Extended Trigger Assembly			

Suregrip Series

DM24 DIGITAL MIG TORCH



Front end consumables

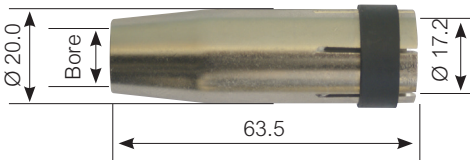
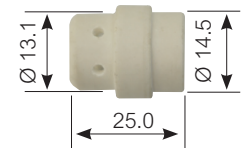
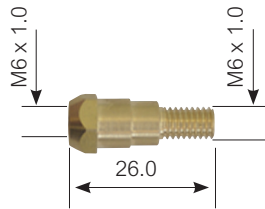
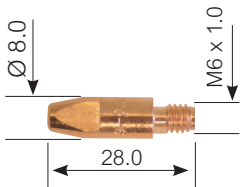

DM24 Contact Tips

Part Number	Description
PCT0009-06	Contact Tip Steel (0.6mm)
PCT0009-08	Contact Tip Steel (0.8mm)
PCT0009-09	Contact Tip Steel (0.9mm)
PCT0009-10	Contact Tip Steel (1.0mm)
PCT0009-12	Contact Tip Steel (1.2mm)
PCT0009-16	Contact Tip Steel (1.6mm)
PCTZR009-09	Contact Tip Steel Long Life (0.9mm)
PCTZR009-12	Contact Tip Steel Long Life (1.2mm)
PCTAL0009-09	Contact Tip Aluminium (0.9mm)
PCTAL0009-10	Contact Tip Aluminium (1.0mm)
PCTAL0009-12	Contact Tip Aluminium (1.2mm)

DM24 Tip Holder

Part Number	Description
PCTH24	Contact Tip Holder

DM24 Gas Diffuser

Part Number	Description
PCGD24	Gas Diffuser

DM24 Gas Nozzle

Part Number	Description
PGN24CYL	Cylindrical Nozzle
PGN24CON	Conical Nozzle
PGN24TAP	Tapered Nozzle
PGN24SPOT	Spot Nozzle

Liners

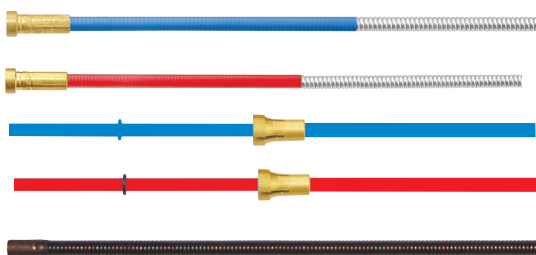

DM24 Liners

Part Number	Description
SLR3M	Red Steel Liner 3 Metre
SLR4M	Red Steel Liner 4 Metre
SLR5M	Red Steel Liner 5 Metre
SLY3M	Yellow Steel Liner 3 Metre
SLY4M	Yellow Steel Liner 4 Metre
SLY5M	Yellow Steel Liner 5 Metre
NKSTL	Neck Spring for Aluminium

These parts are manufactured in China and are offered as replacement parts suitable for "BINZEL®" style torches.