

HOLEMAKER PRO 35

QUALITY, COMPACT & ROBUST FULLY FEATURED MACHINE



The Holemaker PRO 35 is a high quality, compact and robust, fully featured machine. Weighing in at just 10kg, this machine is ideal for those on-site and overhead tasks, whilst the solid, robust construction means the HMPRO35 is perfect for everyday manufacturing type applications.

The 35mm Diameter and 52mm Depth cutting capacity will suffice for most general holemaking requirements. Other standard features include a gravity feed coolant system with a magnetically attached coolant bottle, which can be easily removed and attached to the work piece, allowing coolant feed whilst drilling in horizontal applications. The feed handles can be placed on either the left or right hand side, providing further versatility when using this compact machine in tight positions. Dual rail slide system provides rigidity and eliminates the need for gib adjustments. The well designed cutter guard system is easy to use and practical.

*12mm twist drill capacity using Weldon shank twist drill bits.



Part No.	HMPRO35
Capacity (Diameter)	35mm
Capacity (Depth)	52mm
Motor Power	920Watt
Input Power	1000Watt Single Phase 240V
Speed	350rpm
Weight	10.0kg
Magnetic Dead Lift	9500N-m on 25mm Steel Plate
Stroke	70mm
Height (min / max)	306 / 376mm
Through Spindle Coolant System	
Smart Magnet Technology to ensure sufficient Magnetic Adhesion	
Supplied In Plastic Carry Case with Cutter Guard & Safety Strap	

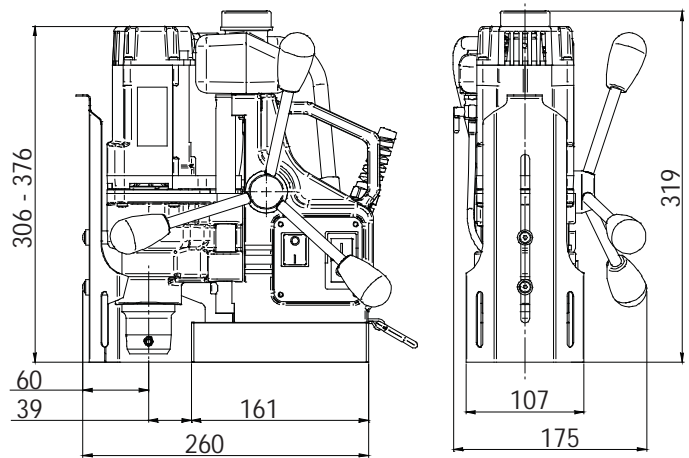

Optional Accessories & Consumables



Holemaker Cutters

Over 700 different types and sizes, stocked. Our diverse range of styles and wide range of sizes means that even the most demanding jobs can be completed successfully.

- Ability to cut difficult materials such as Bialloy, Wear Plate, Stainless Steel and Exotic Alloys
- Large diameters and depths
- General engineering
- Railway line and more!



Twist Drills - Weldon Shank

- 3/4" Weldon Shank for use in Magnetic Base Drilling Machines
- Designed to utilise through spindle coolant system, to provide coolant to the cutting edge



Countersinks

- With 3/4" Weldon Shank for use in Magnetic Base Drilling Machines
- 3 flute high speed steel

Part No.	Size Maximum	Angle	Shank Diameter
SCS90/30	30mm	90°	3/4" (19.05mm)
SCS90/40	40mm	90°	3/4" (19.05mm)
SCS90/55	55mm	90°	3/4" (19.05mm)