

# BOSSSAFE



## **Instruction for use Bossafe Electronic Welding Helmet**



# WARNING

**Read and understand all instructions before using!**

**Bosssafe Solar Powered Auto Darkening Welding Helmets are designed to protect the eyes and face from sparks, spatter, and harmful radiation under normal welding conditions. They will not protect against severe impact hazards, including fragmenting grinding disks, and they must never be used for grinding.**

**This helmet will never protect against explosive devices or corrosive liquids. Machine guards or eye splash protection must be used when these hazards are present.**

**Impact resistant, primary eye protection, spectacles or goggles that meet current ANSI specifications, must be worn at all times when using this welding helmet.**

**Avoid work positions that could expose unprotected areas of the body to spark, spatter, direct and/or reflected radiations. Use adequate protection if exposure can not be avoided.**



## WARNING

Before each use, check that the protection plates are clean and that no dirt is covering the sensors on the front of the lens.

Inspect all operating parts before each use for signs of wear or damage. Any scratched, cracked, or pitted parts should be replaced immediately before using again to avoid severe personal injury.

Do not make any modifications to either the welding lens or helmet, other than those specified in this manual. Do not use any replacement parts other than those specified in this manual. Unauthorised modifications and replacement parts will void the warranty and expose the user to the risk of personal injury.

Failure to follow these warnings and/or failure to follow all of the operating instructions could result in severe personal injury.

---

### 1. Product features

- > This product is a completely new design, with shell material that is resistant to high and low temperatures, corrosion resistant, flame retardant, soft, light tight, of high intensity, and durable.
- > Enables clear vision on the work piece both prior and during welding, which means improved quality and higher efficiency.
- > Overall process protection against ultraviolet (UV) and infrared (IR) radiation. This helmet is equipped with lithium battery and solar cells that extends the life of the battery.
- > The product conforms with related DIN, ISO, EN379 safety standards and ANSI Z87.1 –1989 standard.

## Bosssafe Auto Darkening Welding Helmet assembly diagram and spare parts list

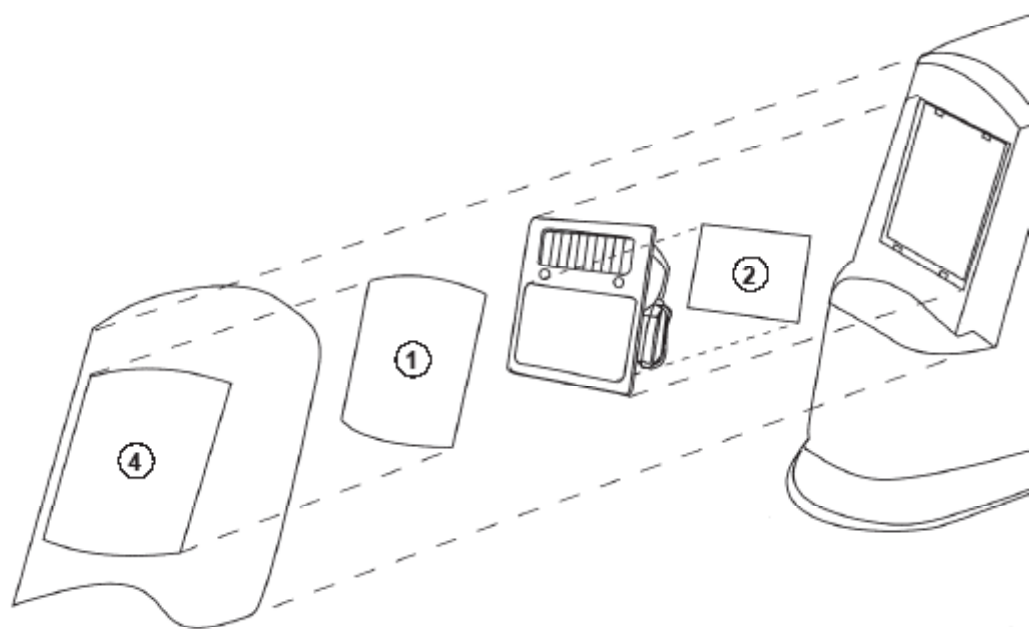

Ref	Code	Description
1	700228	Outer Lens – Bosssafe Helmet
2	700235	Inner Lens - Bosssafe Helmet
3	700230	Head Harness and screw set – Bosssafe Helmet

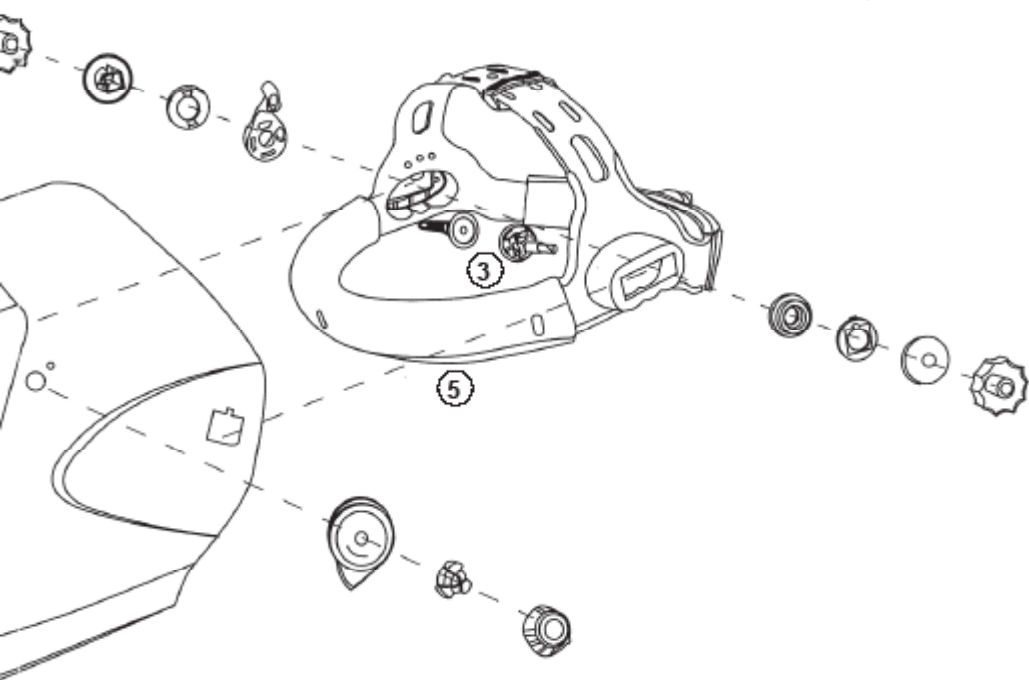

Ref	Code	Description
4	700231	Outer lens support – Bosssafe Helmet
Not shown	700232	Battery Set – Bosssafe Helmet
5	700234	Sweatband – Bosssafe Helmet

---

## 2. Operating instructions

1. Peel off the protective film from the inside and outside of the surface of lens.
2. Prior to welding, the filter screen is in a transparent and clear state, enabling a clear vision of work piece, the moment welding starts the filter screen automatically changes from clear to dark state. When welding stops, the filter screen automatically changes from dark to clear state.
3. Adjust the time delay knob according to different welding processes.
4. Adjust the shade number knob according to different welding current and welding process. To select proper shade number – see attached table: 1.
5. Adjust headband – see attached figure.
  - a) Firstly turn the headband until the adjustable knob is to the head's rear position. At the same time, manually press and rotate the adjustable knob counter-clockwise to increase the circumference of the headband or rotate the knob clockwise to decrease the circumference.
  - b) Adjust the overhand band to one of the custom fit positions for proper helmet depth.
  - c) Undo the block nut, so the peg on the side of the welding helmet moves in the stop and set the eye distance to filter.
  - d) Turn the limitation washer to finely adjust the viewing angle of the filter screen.

---

## 2. Warning

- > This helmet applies to all kinds of welding operations.
- > The outside of lens must be equipped with outside protection plate to prevent potential unrepairable hazard.
- > Change the scratched or broken lens frame that reduces visual field and protection as soon as possible.
- > Change the scratched or broken protection plate, do not bump into lens during replacement.

- > Before welding, select proper shade number according to welding process.
- > The operating temperature range is 23°F to 131°F (-5°C to 55°C). When ambient temperature is below the lower limit, the response speed of liquid crystal material in lens frame assembly will slow a little, no other protections will be affected.
- > Do not store lens frame in a location near a heat source or in a damp place.
- > Do not clean lens frame with alcohol, gasoline, or diluted solvent, and do not immerse in water.
- > Frequently change the sweat band.
- > Change damaged or broken parts with parts provided by the supplier.

---

## 4. Maintenance

- > Clean the welding lens with a lint-free tissue or cloth with residential glass detergent. Do not immerse in water or other liquid. Never use solvents or oil to dilute detergent.
- > Use neutral detergent to clean headband.
- > Never directly strike lens.

---

## 5. Technical Specifications

Power supply:	Solar & Lithium combination
Filter size:	4 - 3/8" x 3-5/8" x 1/3" (110 x 90 x 8mm)
UV/IR protection:	Up to Shade DIN 15 at all times
Operating temperature:	23°F ~ 131°F (-5°C ~ 55°C)
Variable dark shade:	Shade DIN 9 ~ 13
Light state:	Shade DIN 4
Switching time (from light to dark):	1/10000s
Delay time (from dark to light):	Adjustable 0.5s ~ 0.8s
Sensitivity adjustable:	3
External shade adjustable knob:	3

# BOSS SAFE

## Shade Guide Table

Welding Process:

Arc Current (Amperes)

	0.5	1	2.5	5	10	15	20	30	40	60	80	100	125	150	175	200	225	250	275	300	350	400	450	500
<b>SMAW</b>								9		10			11					12				13		14
<b>MIG (heavy)</b>											10	11					12					13		14
<b>MIG (light)</b>											10	11				12		13					14	
<b>TIG.GTAW</b>				9			10				11	12				13							14	
<b>MAG/CO2</b>										10	11			12	13							14		
<b>SAW</b>														10	11		12		13		14			
<b>PAC</b>												11				12						13		
<b>PAW</b>				8	9	10		11				12				13			14					

Adopt greater or smaller shade number pursuant to the field condition.

Note: All specifications and technical data subject to change without prior notification.