

BEAVER MATERIALS HANDLING (CONT'D)

BEAVER OXYGEN / ACETYLENE GAS BOTTLE TROLLEY

Designed for use as a trolley, lifting frame or used with a forklift

Product Code	Capacity (kg)	H mm	B mm	W mm	C mm	A mm	D mm	Weight (kg)	UOM
263200T	200	1600	1280	635	394	644	100	76	Each

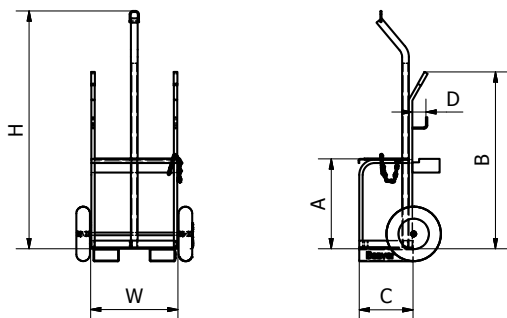

BEAVER SHORT EXTENDABLE FORKLIFT JIB 2.5T

Simple to fit and use. Safe and easy to adjust.

Product Code	Capacity (kg)	Fork Pocket Size mm	Fork Pocket Centres mm	Weight (kg)	UOM
262223	2500	185 x 65	275	100	Each

Working Load Limit (WLL) per position				
Position	1	2	3	4
Extension (mm)	790	1200	1580	1960
WLL (kg)	2500	1200	900	750

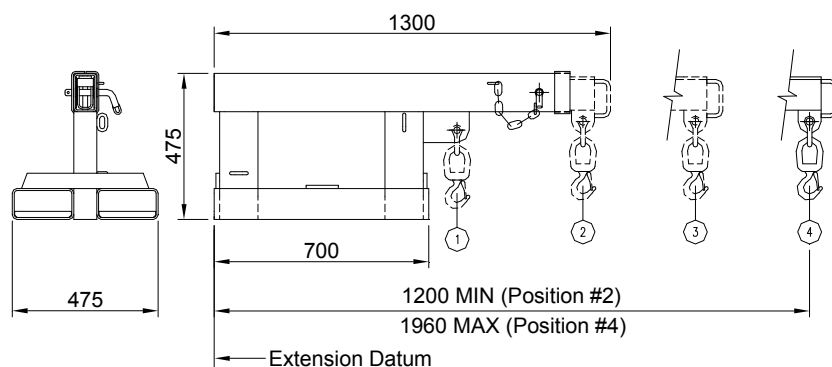

Other sizes and capacities available on request.