



Welding Products

Edition 4
Issued July 2017



Innovation that
makes your job
easier

Global alliances
↳ buying power

Products for professional
metal fabricators

We've been doing this for
over 30 years...
thanks for your support!





MERCHANDISING 4



ABRASIVES 16



CONSUMABLES 24



MIG/TIG TORCHES
& SPARES 34



GAS EQUIPMENT 60



MACHINES 80



ACCESSORIES,
TOOLS, MARKERS 82



SAFETY; EYE, EAR
& RESPIRATORY 102



GLOVES, APPAREL
BLANKETS 128



MERCHANDISING



DISPLAY STAND PROMAX WELDING HELMET RANGE

- Stores total of 8 Helmets with 2 on Display

the ultimate Helmet merchandiser!

More helmet stands on pages 13 & 14



Part No.	Description	Unit
17-DS025	Display Stand - Promax Helmets	Package



DISPLAY STAND WELDING START-UP RANGE - BASIC

- 2 most common helmets
- Common Binzel and Tweco Style Mig parts
- Gas gear
- Gloves
- Basic accessories range
- Mini spools of wire
- Popular Gasless Wire
- Popular Stick Electrodes

*Get a head start in welding
with this easy-sell range!*



Part No.	Description	Unit
17-DS025	Display Stand - Basic Range	Package



DISPLAY STAND WELDING START-UP RANGE - INTERMINIATE

- Full helmet range including lenses to suit (4 Models)
- Mig spares incl Binzel, Tweco and Bernard Style common parts
- Gas gear range – basic most common accessories
- Most common earth clamps and general accessories
- Most common mig wires and General Purpose electrodes
- Nozzle dip, Anti-spatter, blue gloves and chalk



Part No.	Description	Unit
17-DS015	Spinner Stand - Interminate Range	Package
17-DS035	Wall Stand - Interminate Range	Package



DISPLAY STAND COMPREHENSIVE RANGE - MIG TORCHES & SPARES

- Binzel, Tweco & Bernard Style Parts
- Most common sized Mig tips
- Common nozzles, tip holders, gas diffusers, etc.
- Liners including universal series liners
- Most common torch range

With easy selection chart to help your customers find the right part



Part No.	Description	Unit
17-DS013/1	Spinner Stand - MIG Torches & Spares	Package
17-DS033/1	Wall Stand - MIG Torches & Spares	Package



DISPLAY STAND COMPREHENSIVE RANGE - TIG TORCHES & SPARES

- 17/18/26 series common parts – collets, collet bodies, back caps, torch bodies, Gas lens cups and collet bodies, alumina cups
- 9/20 series common parts – collets, collet bodies, back caps, torch bodies, Gas lens cups and collet bodies, alumina cups
- Universal Tig Tungstens
- The best Tig Welding Helmet in the World - Jackson WH70
- Aluminium and stainless steel filler rod
- Tig welding gloves
- Two most common torches



Part No.	Description	Unit
17-DS013/2	Spinner Stand - TIG Torches & Spares	Package
17-DS033/2	Wall Stand - TIG Torches & Spares	Package



DISPLAY STAND COMPREHENSIVE RANGE - GAS EQUIPMENT

- Blowpipe Handle, Cutting attachment, Brazing Mixer
- Flashback arrestors and quick couplings
- LPG and Acetylene cutting, gouging and brazing tips – common sizes
- Tip cleaners, oxy goggles and general consumables
- Range of common hoses & hose fittings
- Range of common regulators
- LPG Burner / Heating Torch

*Quality gas gear that
won't let you down*



Part No.	Description	Unit
17-DS014	Spinner Stand - Gas Equipment	Package
17-DS034	Wall Stand - Gas Equipment	Package



DISPLAY STAND COMPREHENSIVE RANGE - ACCESSORIES

- Earth clamps, Alligator & G-type
- Electrode holders, mig pliers and magnetic welders squares
- Common brazing rod range
- Cable joiners and cable connectors
- Nozzle dip, anti-spatter, chalk
- Chipping hammers
- Booster clamps



Part No.	Description	Unit
17-DS016	Spinner Stand - Accessories	Package
17-DS036	Wall Stand - Accessories	Package



DISPLAY STAND COMPREHENSIVE RANGE - WELDING SAFETY & APPAREL

- Most common size welding jackets
- Leather jackets, FR with leather sleeves jackets, Hi-vis FR jackets, FR 'Blue Flame' Jackets
- Hoods and Aprons
- Full glove range – riggers, blue gloves, long gloves, Tig gloves
- Most common blankets and curtains
- Ear plugs and common range of respirators
- Popular Safety Spec Range

No more selling Jackets out of packets!



Part No.	Description	Unit
17-DS018	Spinner Stand - Welding Safety & Apparel	Package
17-DS038	Wall Stand - Welding Safety & Apparel	Package



DISPLAY STAND COMPREHENSIVE RANGE - TAIPAN ABRASIVES

- Original and Platinum series flap discs – mixed grits and sizes
- 'Original Cuttin Discs
- 'Platinum' Cutting Discs (wall stand only)
- 'Chop-saw' Cutting Wheels (wall stand only)
- Grinding Disc Range (wall stand only)
- Cup brushes, bevel brushes and spindle brushes
- Pipeline wheels and crimped wheel brushes
- Miscellaneous hand brushes – wooden and plastic

*A Global Abrasive brand
 your customers will love!*



Part No.	Description	Unit
17-DS011	Spinner Stand - Taipan Abrasives	Package
17-DS031	Wall Stand - Taipan Abrasives	Package



DISPLAY STAND COMPREHENSIVE RANGE - PROMAX HELMETS & LENSES

- Promax 200 – base helmet
- Promax 350 Blue and 'Fire metal' – everyday helmet
- Promax 500 – Wide view helmet
- Range of Cover lenses to suit common helmets on the market
- Magnification lenses and batteries
- Universal sweatbands
- Point-of-Sale helmet info cards

*Become the 'go to' store for
welding Helmets & Lenses!*



Part No.	Description	Unit
17-DS017	Spinner Stand - Promax Helmets & Lenses	Package
17-DS037	Wall Stand - Promax Helmets & Lens	Package



DISPLAY STAND COMPREHENSIVE RANGE - PROMAX HELMETS

- Promax 200 – base helmet x 4
- Promax 350 Blue and 'Fire metal' – everyday helmet x 16
- Promax 500 – Wide view x 4
- Lenses to Suit
- Point-of-Sale Helmet info cards

*24 top-selling Helmets
 professionally presented!*



Part No.	Description	Unit
17-DS037/1	Wall Stand - Promax Helmets	Package



DISPLAY STAND JACKSON® & PROMAX 400R HELMETS

- Jackson® WH70 Helmet
- Jackson® WH70 Airmax Helmet / Respirator System
- Weldclass Promax 400R Helmet / Respirator System
- Jackson Mag Lens Adaptors (not pictured)
- Jackson Hard-Hat Kit
- Banner Explains the Benefits of Jackson® Technology to your customers

Jackson: a world leader brought to your showroom!

Air-Fed Helmets professionally presented!



Part No.	Description	Unit
17-DS027	Display Stand - Jackson & Airfed Helmets	Package



ABRASIVES



A quick look at...

TAIPAN ABRASIVES BRAND

Worlds most Venomous snake...

And an Abrasive brand that won't let you down!



Tested, Tried & Proven

Used by Professional Fabricators world-wide for over 15 years. Backed by an aggressive R&D program, focused on delivering products that cut, remove & shape metal with maximum efficiency.



TAIPAN®
ABRASIVES GROUP
The brand with **bite!**

Safety First

Taipan discs* conform to AS1788.1, and are certified to EN standards by OSA &/or MPA regulatory bodies.

*Cutting, grinding & flap discs



A Global Force in Abrasives

Check out www.taipanabrasives.com



CUTTING DISCS TAIPAN ORIGINAL INOX THIN

- Excellent Disc Life and Value for Money
- Smooth & Safe Cutting - Unique Anti-Friction Surface on both sides of disc: Improves the Ease of the cut, Increases Cut Speed and Prevents Jamming and Kick-back.
- Optimum Performance on both Mild and Stainless Steel.
- INOX/Iron-Free for Safe use on Stainless Steel
- Metal centre ring for maximum safety

*World-wide
Taipan best
seller!*



Part No.	Description	Unit
TO-6202	100mm (4") x 1.0mm	Each
TO-6204	115mm (4.5") x 1.0mm	Each
TO-6218	115mm (4.5") x 1.6mm	Each
TO-6206	125mm (5") x 1.0mm	Each
TO-6220	125mm (5") x 1.6mm	Each
TO-6224	180mm (7") x 1.6mm	Each
TO-6226	230mm (9") x 1.9mm	Each

CUTTING DISCS TAIPAN PLATINUM 'RAZOR-HUB XT'

- INOX/Iron-Free for safe use on Stainless Steel
- OSA approved for peace of mind
- For Mild & Stainless steels

*Unique Safety
Hub System
= the Longest
Lasting Taipan
disc yet!*



Unique Steel Hub System
Now you can have both...
Safety AND Fine/Fast cutting !!

Superior Safety & Strength
Hub system provides Rigidity & Strength like no other thin disc.
Steel hub is larger than the grinder clamping area & will not break away around the edge of the clamping area.

Fast & Precise
1.0mm thickness for fine and fast cutting, yet exceptionally safe.
The inherent strength of the hub system means Less Flex, greater Precision and Control.

Looooong-Life!
The highest performing, longest-lasting Taipan thin disc yet!! Hub design also allows the whole disc to be used, no wastage.

Deeper Cutting & Better Vision
Tight radius of the hub allows for deeper cutting, and better vision.
Safe full-depth cutting, due to the rigid anti-flex Hub system.



Part No.	Description	Unit
TP-6090	125mm (5") x 1.0mm INOX Razor-Hub XT with Safety Hub	Each



CUTTING DISCS TAIPAN ORIGINAL - STANDARD THICKNESS

- Excellent Disc Life and Value for Money
- Suitable for both Mild & Stainless Steels
- 2.5mm/2.8mm Thickness for General-Purpose Cutting & Maximum Safety
- INOX/Iron-Free for Safe use of Stainless Steel



Part No.	Description	Unit
TO-6270	100mm (4") x 2.5mm INOX Flat	Each
TO-6272	115mm (4.5") x 2.5mm INOX Flat	Each
TO-6274	125mm (5") x 2.5mm INOX Flat	Each
TO-6109	230mm (9") x 2.8mm INOX DPC	Each

CHOP-SAW DISCS TAIPAN ORIGINAL INOX

- Excellent Disc Life and Value for Money
- Smooth & Safe Cutting - Anti-Friction Surface on both sides of disc: Improves the Ease of the cut, Increases Cut Speed and Reduces Wear & Tear on the Saw
- Optimum Performance on both Mild and Stainless Steel
- For Portable 240V Chop-Saws / Cutting Saws
- INOX (Iron-Free) for Safe Use on Stainless Steel



Part No.	Description	Unit
TO-6532	350mm (14) x 2.8mm x 25.4mm Bore" - Max Rpm 4,400	Each
TO-6534	400mm (16) x 3.0mm x 25.4mm Bore" - Max Rpm 3,800	Each



GRINDING DISCS TAIPAN ORIGINAL INOX 'FAST'

- "Fast" Series: Medium Hardness for Fast Grinding of Steel & Stainless-Steel.
- INOX (Iron-Free) for Safe Use on Stainless Steel.
- Fast Metal Removal, Good Disc Life and Great Value for Money
- Designed to provide fast metal removal with moderate grinding pressure



Part No.	Description	Unit
TO-6120	100mm (4") x 6.5mm	Each
TO-6122	115mm (4 1/2") x 6.5mm	Each
TO-6124	125mm (5") x 6.5mm	Each
TO-6128	180mm (7") x 7.0mm	Each
TO-6130	230mm (9") x 7.0mm	Each



**FLAP DISCS
 TAIPAN ORIGINAL**



world-wide Taipan best seller!

- Tried, Tested & Proven by Australian Fabricators for Over 15 Years.
- Up to 30% More Grit Cloth than other brands = Longer Life & Less Down-Time.
- Manufactured in Europe
- For Steel, Stainless-Steel & Aluminium

Part No.	Description	Unit
TO-5002	100mm (4") Z40 Grit	Each
TO-5004	100mm (4") Z60 Grit	Each
TO-5006	100mm (4") Z80 Grit	Each
TO-5008	100mm (4") Z120 Grit	Each
TO-5012	115mm (4.5") Z40 Grit	Each
TO-5014	115mm (4.5") Z60 Grit	Each
TO-5016	115mm (4.5") Z80 Grit	Each
TO-5018	115mm (4.5") Z120 Grit	Each
TO-5022	125mm (5") Z40 Grit	Each
TO-5024	125mm (5") Z60 Grit	Each
TO-5026	125mm (5") Z80 Grit	Each
TO-5028	125mm (5") Z120 Grit	Each
TO-5042	180mm (7") Z40 Grit	Each
TO-5044	180mm (7") Z60 Grit	Each
TO-5046	180mm (7") Z80 Grit	Each
TO-5048	180mm (7") Z120 Grit	Each



Why choose...

TAIPAN ORIGINAL FLAP DISCS

- *Thicker & more flaps*
- *Lasts longer*
- *OSA Approved for peace of mind*
- *Tried & Tested by Industry for over 15 Years*



*Call 1300 784 200
 to find your nearest Taipan Distributor*



CUP BRUSHES TWIST-KNOT TAIPAN

- Multi-Thread design: Supplied with thread adaptors to fit any common grinder thread: M14x2, M10x1.5 & M10x1.25
- Professional Quality: Tempered Steel Wire, Smooth Action and Perfect Balance
- Coarse Twist Knot Steel Wire: Aggressive Action, Rust & Scale Removal, Surface Preparation, etc
- Cup Shape for Flat Surfaces, External Corners & Edges, etc



Part No.	Description	Unit
TO-3030	65mm Multi-Thread Mild-Steel	Each
TO-3032	75mm Multi-Thread Mild-Steel	Each
TO-3620	75mm Multi-Thread Stainless-Steel	Each

CUP BRUSHES TWIST-KNOT W/SKIRT TAIPAN

- Removable Skirt: After Initial Wear, Remove the Skirt to give a '2nd life'
- Professional Quality: Tempered Steel Wire, Smooth Action and Perfect Balance
- Coarse Twist Knot Steel Wire: Aggressive Action, Rust & Scale Removal, Surface Preparation, etc
- Cup Shape for Flat Surfaces, External Corners & Edges, etc



Part No.	Description	Unit
TO-3040	075mm Multi-Thread Mild-Steel	Each
TO-3042	100mm M14x2 Mild-Steel	Each
TO-3628	100mm M14x2 Stainless-Steel	Each
TO-3044	125mm M14x2 Mild-Steel	Each
TO-3630	125mm M14x2 Stainless-Steel	Each

CUP BRUSHES CRIMPED TAIPAN

- Professional Quality: Tempered Steel Wire, Smooth Action and Perfect Balance
- Brass-Coated Crimped (wavy) Wire for mild scrubbing action, light rust removal, deburring, etc
- Cup Shape for Flat Surfaces, External Corners & Edges, etc



Part No.	Description	Unit
TO-3092	075mm Multi-Thread Brass-Coated Steel	Each



PIPELINE WHEEL BRUSHES TAIPAN

- 40 Knots Per Wheel for Long Brush Life
- Professional Quality: Tempered Steel Wire, Smooth Action and Perfect Balance
- Ideal for Pipeline Weld Bead Cleaning; including during root pass, inter-pass, hot pass operations, etc
- Coarse Twist Knot Steel Wire For Fast Removal of Slag, Spatter & Oxidisation
- 22mm Bore/Arbor for use on 5", 7" or 9" angle grinders



Part No.	Description	Unit
TO-3086	125mm x 6mm Twist-Knot Mild-Steel	Each
TO-3670	125mm x 6mm Twist-Knot Stainless-Steel	Each

BEVEL BRUSHES TWIST-KNOT TAIPAN

- Multi-Thread design: Supplied with thread adaptors to fit any common grinder thread: M14x2, M10x1.5 & M10x1.25
- Professional Quality: Tempered Steel Wire, Smooth Action and Perfect Balance
- Coarse Twist Knot Steel Wire: Aggressive Action, Rust & Scale Removal, Surface Preparation, etc
- Bevel/Angled/Saucer Shape for work in corners, contours, channels, Vs, etc



Part No.	Description	Unit
TO-3098	100mm (4") Multi-Thread Mild-Steel	Each
TO-3610	100mm (4") Multi-Thread Stainless-Steel	Each

WHEEL BRUSHES CRIMPED TAIPAN

- Multi-bore: Includes set of bushes to suit various grinders.
- Professional Quality: Tempered Steel Wire, Smooth Action
- For Bench / Pedestal Grinders
- Brass-Coated Crimped (wavy) Wire for mild scrubbing action, rust, scale, paint removal, deburring, etc



Part No.	Description	Unit
TO-3076	150mm (6") x 19mm	Each
TO-3078	200mm (8") x 25mm	Each



HAND BRUSHES 4-ROW WOODEN HANDLE TAIPAN

- Long Handle for Extended Reach
- Great Value
- Straight wire for heavy-duty action: rust & scale removal, de-slagging, etc
- 4-Row for flat surfaces, outside corners & edges, etc
- 355mm long, 72 tuft (18 x 4 rows)



Part No.	Description	Unit
TO-3210	Mild-Steel	Each
TO-3212	Stainless-Steel	Each

HAND BRUSHES 4-ROW PLASTIC HANDLE TAIPAN

- Ergonomic & Long-Life Design
- Plastic Handle Prevents Bristles Coming Loose, even Under Vigorous Use
- Straight wire for heavy-duty action: rust & scale removal, de-slagging, etc
- 4-Row for flat surfaces, outside corners & edges, etc
- 280mm long, 58 tuft (14 x 4 rows + 2)



Part No.	Description	Unit
TO-3206	Mild-Steel	Each
TO-3208	Stainless Steel	Each



HAND BRUSHES 1 ROW TAIPAN

- Ergonomic & Long-Life Design
- Single row curved style - ideal for internal corners, channels, etc
- Crimped (wavy) wire for mild scrubbing action, light rust removal, deburring, etc
- Plastic Moulded Handle



Part No.	Description	Unit
TO-3202	Brass-Coated Steel	Each
TO-3204	Stainless-Steel	Each

SPINDLE MOUNT END BRUSHES TAIPAN

- Professional Quality: Tempered Steel Wire, Smooth Action
- 6.4mm/¼" Shaft/Spindle
- Brass-Coated Crimped (wavy) Wire for mild scrubbing action, light rust removal, deburring, etc
- End shape for narrow areas, internal holes, cavities, cylinders, etc



Part No.	Description	Unit
TO-3060	17mm Crimped Brass-Coated Steel	Each
TO-3062	25mm Crimped Brass-Coated Steel	Each

SPINDLE MOUNT CUP BRUSHES TAIPAN

- Professional Quality: Tempered Steel Wire, Smooth Action
- 6.4mm/¼" Shaft/Spindle
- Brass-Coated Crimped (wavy) Wire for mild scrubbing action, light rust removal, deburring, etc
- Cup Shape for Flat Surfaces, External Corners & Edges, etc



Part No.	Description	Unit
TO-3050	50mm Crimped Brass-Coated Steel	Each
TO-3052	75mm Crimped Brass-Coated Steel	Each

SPINDLE MOUNT WHEEL BRUSHES TAIPAN

- Professional Quality: Tempered Steel Wire, Smooth Action
- 6.4mm/¼" Shaft/Spindle
- 50mm & 75mm: Brass-Coated Crimped (wavy) Wire for mild scrubbing action, light rust removal, deburring, etc
- 80mm: Twist-knot wire for coarse action, rust & scale removal, surface preparation, etc
- Wheel shape for narrow areas, corners, channels, internal curves, etc



Part No.	Description	Unit
TO-3070	50mm Crimped Brass-Coated Steel	Each
TO-3072	75mm Crimped Brass-Coated Steel	Each
TO-3074	80mm Twist-Knot Mild-Steel	Each



CONSUMABLES



A quick look at...

Weldclass Platinum **GL-II GASLESS WIRE**

Platinum Performance

Rated by thousands of Aussie fabricators as Australia's No. 1 Gasless Wire !

Vacuum Foil-Sealed Spools

For exceptional storage life



Ultra-Smooth & Easy to Use!

Very smooth Arc, Minimal spatter, Low-Fume, Easy-to-remove Slag. Tolerant to variations in machine settings, quick & easy to set up.

Many Applications

For All-Positional, Single and Multi-Pass Welds. Ideal for mild or galvanised steel.

See Page 29...



ELECTRODES WELDCLASS PLATINUM 12V (GP)

- Excellent Operator Appeal: Very Smooth & Stable Arc, Easy Striking, Low Spatter, Self-Detaching / Easy-to-remove Slag
- User Friendly: Tolerant to Dirty / Rusty Steel & Poor Fit Up
- All-Positional: Fast-Freezing Slag for fillet & butt welding in All Positions, including Vertical Down
- Ideal General Purpose electrode for fabrication, repair, fencing, light structural & more
- Unbeatable Performance on: Mild, Galvanized, Plate, Sheet & Tubular/ RHS Steel
- AWS specification A5.1
E6013 / AS/NZS Specification 1553.1
E4112-0



Part No.	Description	Unit
2-E12V/26	2.6mm	Pkt 2.5kg
2-E12V/32	3.2mm	Pkt 5kg
P2-E12V/26HP	Handy-Pack 2.6mm	Pkt 16rd
P2-E12V/32HP	Handy-Pack 3.2mm	Pkt 14rd

Why choose...

PLATINUM 12V ELECTRODES

- *Ultra smooth arc*
- *Easy striking*
- *All-positional, including vertical-down*



Call today to request a sample pack!



ELECTRODES LOW-HYDROGEN 7016

- Low Fume and good crack resistance
- Good impact toughness
- Low Hydrogen electrode for welding high strength steel
- Commonly used on steel members subject to high load: machinery parts, ships, bridges, buildings and pressure vessels
- All welding positions, excluding vertical down
- AWS Classification A5.1 E7016



Part No.	Description	Unit
2-701626	2.6mm	Pkt 5kg
2-701632	3.2mm	Pkt 5kg
2-701640	4.0mm	Pkt 5kg

ELECTRODES STAINLESS-STEEL 316L

- Very Smooth Running and Easy to use
- Heavy-Duty Re-Usable Plastic Packet with Screw-Top Lid
- For welding common 300 series stainless steel such as 301, 302, 304, 304L and 316L
- All welding positions, excluding vertical down
- AWS Classification A5.4 E316L-16



Part No.	Description	Unit
2-316L26	2.6mm	Pkt 2.5kg
P2-316L26	Handy-Pack 2.6mm	Pkt 16rd
2-316L32	3.2mm	Pkt 2.5kg
P2-316L32	Handy-Pack 3.2mm	Pkt 12rd

ELECTRODES STAINLESS-STEEL 309L

- Very Smooth Running and Easy to use
- Heavy-Duty Re-Usable Plastic Packet with Screw-Top Lid
- For welding of matching 309/309L and a wide range of 300 & 400 stainless steels
- Also used for welding dissimilar steels, including stainless-steel to mild steel
- All welding positions excluding vertical down
- AWS Classification A5.4 E309L-16



Part No.	Description	Unit
2-309L26	2.6mm	Pkt 2.5kg
2-309L32	3.2mm	Pkt 2.5kg



ELECTRODES UNIVERSAL 312

- For welding dissimilar or unknown steels
- Heavy-Duty Re-usable Plastic Pack with Screw-Top Lid
- Commonly used for repair and maintenance
- All welding positions excluding vertical down
- AWS Classification AWS A5.4 E 312-16



Part No.	Description	Unit
2-31226	2.6mm	Pkt 2.5kg
P2-31226	Handy-Pack 2.6mm	Pkt 16rd
2-31232	3.2mm	Pkt 2.5kg
P2-31232	Handy-Pack 3.2mm	Pkt 12rd

ELECTRODES CAST IRON NCI

- High nickel content electrode for repairing and joining cast iron
- Suitable for mechanite, alloy and malleable cast iron
- Weld deposits are machinable
- Weld positions : flat, horizontal
- AWS Classification A5.15 ENi - CI



Part No.	Description	Unit
2-NCI32	3.2mm	Pkt 2.5kg
P2-NCI32	Handy-Pack 3.2mm	Pkt 6rd

ELECTRODES HARDFACING 700

- For 'general purpose' hard-facing of earthmoving & ground-engaging implements
- Good Abrasion Resistance and Moderate Impact Strength
- 55 HRC Typical Hardness of All Weld Metal
- Ideal for points, bucket teeth, agricultural & earthmoving equipment
- Weld positions : Flat, horizontal and vertical up



Part No.	Description	Unit
2-EHF700BB/32	3.2mm	Pkt 5kg

GOUGING CARBONS

- Designed for gouging and cutting most steels
- High speed process
- Removal of weld material, cracks or defect removal
- Operates on DC welding power source and requires air arc gouging torch with compressed air supply



Part No.	Description	Unit
2-GC5	5mm (3/16")	Box 50
2-GC65	6.5mm (1/4")	Box 50
2-GC8	8mm (5/16")	Box 50
2-GC95	9.5mm (3/8")	Box 50
2-GC13	13mm (1/2")	Box 50



MIG WIRE STEEL PLATINUM 'XT6'

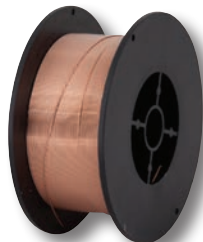
- Excellent operator appeal
- Excellent feedability, Low spatter & low fume
- Premium S6 grade, layer wound copper coated low carbon steel mig wire
- For welding a wide range of mild and mid strength low carbon steels and galvanised steel
- All positional
- AWS Classification AWS A5.18 ER70S-6



Part No.	Description	Unit
2-XMS608/06	200mm/5kg Spool 0.6mm	Spl 5kg
2-XMS608/08	200mm/5kg Spool 0.8mm	Spl 5kg
2-XMS608/09	200mm/5kg Spool 0.9mm	Spl 5kg
2-XMS612/08	300mm/15kg Spool 0.8mm	Spl 15kg
2-XMS612/09	300mm/15kg Spool 0.9mm	Spl 15kg
2-XMS612/12	300mm/15kg Spool 1.2mm	Spl 15kg

MIG WIRE STEEL MINI-SPOOLS

- Premium S6 grade, copper coated low carbon steel mig wire for welding a wide range of mild and mid strength steels



Part No.	Description	Unit
P2-084MW	100mm/0.7kg Spool 0.8mm	Spl 4in
P2-094MW	100mm/0.7kg Spool 0.9mm	Spl 4in

MIG WIRE STAINLESS-STEEL 316LSI

- High grade wire for welding many 300 & 400 series stainless steels
- Low carbon
- Excellent edge wetting & arc stability
- AWS Classification A5.9 ER316Lsi



Part No.	Description	Unit
P2-MW316L04/08	100mm/0.9kg Spool 0.8mm	Spl 0.9kg 4in
P2-MW316L04/09	100mm/0.9kg Spool 0.9mm	Spl 0.9kg 4in
2-MW316L08/08	200mm/5kg Spool 0.8mm	Spl 5kg
2-MW316L08/09	200mm/5kg Spool 0.9mm	Spl 5kg
2-MW316L12/09	300mm/12.5kg Spool 0.9mm	Spl 12.5kg

MIG WIRE ALUMINIUM 5356

- General purpose aluminium wire for welding a wide range of cast & wrought aluminium alloys.
- Ideal for welding 5083,5086,5454 & 5356 grade aluminium
- AWS Classification A5.10 ER5356



Part No.	Description	Unit
P2-MW535604/09	100mm/0.45kg Spool 0.9mm	Spl 0.45kg 4in
P2-MW535604/12	100mm/0.45kg Spool 1.2mm	Spl 0.45kg 4in
2-MW535608/09	200mm/2kg Spool 0.9mm	Spl 2kg
2-MW535608/10	200mm/2kg Spool 1.0mm	Spl 2kg
2-MW535608/12	200mm/2kg Spool 1.2mm	Spl 2kg
2-MW535612/09	300mm/6kg Spool 0.9mm	Spl 6kg
2-MW535612/10	300mm/6kg Spool 1.0mm	Spl 6kg
2-MW535612/12	300mm/6kg Spool 1.2mm	Spl 6kg

WIRE - GASLESS PLATINUM 'GL-11'

- Ultra-Smooth Running with Minimal Spatter
- Suitable for Single or Multi-Pass Welds
- Vacuum Foil-Sealed Spool, for Exceptional Storage Life in All Conditions
- Easy to use, even on steel that is slightly rusty or dirty and on painted steel surfaces
- All positional wire, for use on mild and galvanised steel
- Ideal for portable use - no gas required
- Ideal for outdoor or onsite use and welding in windy conditions
- AWS Classification A5.20 E 71T-11



Rated by Thousands of Aussie welder's as Australia's No. 1 Gasless wire!

Part No.	Description	Unit
2-088FM	200mm/4.5kg Spool 0.8mm	Spl 4.5kg
2-098FM	200mm/4.5kg Spool 0.9mm	Spl 4.5kg
2-128FM	200mm/4.5kg Spool 1.2mm	Spl 4.5kg
2-GWS1115/09	300mm/15kg Spool 0.9mm	Spl 15kg
2-GWS1115/12	300mm/15kg Spool 1.2mm	Spl 15kg
2-GWS1115/16	300mm/15kg Spool 1.6mm	Spl 15kg

Why choose...

PLATINUM GL-11 GASLESS WIRE

"... After inspecting the first few GL-11 welds I have finally found what I was looking for. I can honestly say none of the other brands I've used have come close to the quality of GL-11. It flows smoothly with minimal spatter and weld appearance is also very good ..."

Genuine End User Comment



WIRE - GASLESS PROMAX 'E-21'

- Suitable for All-Positional, Single and Multi-Pass Welds
- For welding mild & galvanized (Gal) steels
- Ideal for portable use - no gas required
- Ideal for outdoor or onsite use and welding in windy conditions
- Premium E71T-11 Industrial Grade
- Layer wound - for smooth wire feeding
- AWS Classification A5.20 E71T-11

*Great Value!
Industrial grade*



Part No.	Description	Unit
WC-00259	200mm/4.5kg Spool 0.8mm	Spl 4.5kg
WC-00260	200mm/4.5kg Spool 0.9mm	Spl 4.5kg
WC-00262	200mm/4.5kg Spool 1.2mm	Spl 4.5kg

Why choose...

PLATINUM GL-11 GASLESS WIRE

*Looking for Australia's smoothest,
most user-friendly gasless wire?
If you want the best-of-the-best then
you need Weldclass "Platinum GL-11".*



check out...



WIRE - GASLESS MINI-SPOOLS

- Ideal for portable use - no gas required
- Easy to use even on steel that is slightly rusty or dirty
- All positional wire, for general purpose use on mild and galvanised steel

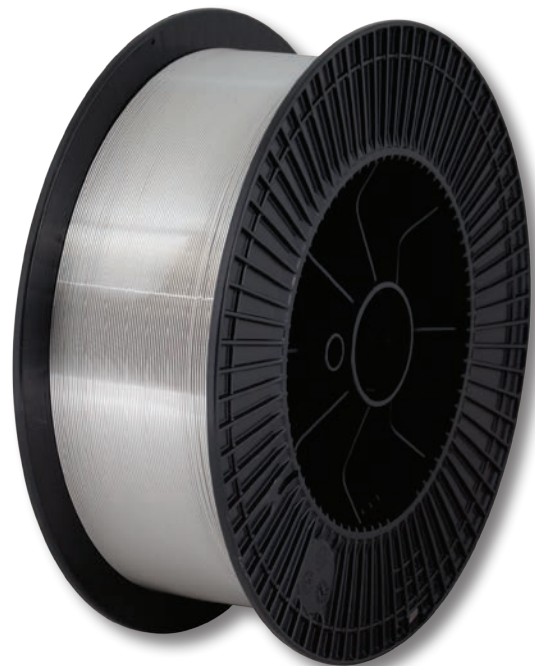


Part No.	Description	Unit
P2-084FM	100mm/0.9kg Spool 0.8mm	Spl 0.9kg 4in
P2-094FM	100mm/0.9kg Spool 0.9mm	Spl 0.9kg 4in



WIRE - HARDFACING CRC

- Premium quality gasless hardfacing wire for components subject to severe abrasion and moderate impact loading
- Very high chromium content for exceptional wear life
- Proven to outlast standard hardfacing electrodes and wires many times over
- Our No. 1 recommended hardfacing product for ground engaging equipment, such as points, tynes, bucket lips, and rippers etc.
- Also used for conveyer screws, crushers, dredge cutter heads and rollers etc.
- Gasless wire for ease of use in the field or in the workshop (no gas required)



Part No.	Description	Unit
2-HFCRC08/12	200mm/5kg Spool 1.2mm	Spl 5kg 8in
2-HFCRC15/12	300mm/15kg Spool 1.2mm	Spl 15kg
2-HFCRC15/16	300mm/15kg Spool 1.6mm	Spl 15kg



WIRE - FLUX CORED PLATINUM 71-XM (E71T-1M)

- Flux Cored Wire used with Gas
- Smooth running low spatter wire for welding mild steel and medium strength steels.
- Good weld appearance, excellent operator appeal, good impact strength
- Commonly used in mining, machinery & heavy-structural applications
- All positional welding
- AWS Classification: A5.20 E71T-1M/9M H8
- Use with CO₂+Ar Mixed Gas

*Ultra-Smooth & stable arc =
hassle-free welding & maximum
productivity*



Part No.	Description	Unit
WC-05362	1.2mm 300mm/15kg Spool	Spl 15kg
WC-05364	1.6mm 300mm/15kg Spool	Spl 15kg



FILLER ROD STAINLESS STEEL 316L

- For TIG welding common 300 series stainless steels, such as 301, 302, 304, 304L, 316, 316L also 409, 444 and 3cr12.
- AWS Classification A5.9 ER 316L



Part No.	Description	Unit
2-FR316L/16	1.6mm	Per Kg
2-FR316L/24	2.4mm	Per Kg

FILLER ROD ALUMINIUM 5356

- For a wide range of aluminium alloys, general aluminium fabrication and repair
- 5% Magnesium content
- AWS Classification A5.10 ER 5356



Part No.	Description	Unit
2-FR5356/16	1.6mm	Per Kg
2-FR5356/24	2.4mm	Per Kg
2-FR5356/32	3.2mm	Per Kg

BRAZING ROD SILVER 45%

- General purpose low temperature brazing
- Recommended for steel, nickel, copper, etc
- Very fast thin flowing alloy
- Excellent strength



Part No.	Description	Unit
P2-SB4516B/2	1.6mm Bare	Pkt 2
P2-SB4516B/5	1.6mm Bare	Pkt 5rd
P2-SB4516F/2	1.6mm Flux Coated	Pkt 2
P2-SB4516F/5	1.6mm Flux Coated	Pkt 5rd

BRAZING ROD MANGANESE BRONZE

- General purpose bronze filler rod
- For steel, cast iron, malleable iron, copper, copper alloys & stainless steel
- AWS Classification A5.8 RBCuZn-C



Part No.	Description	Unit
P2-FRMB24B/10	2.4mm Bare	Pkt 10rd
P2-FRMB24F/10	2.4mm Flux Coated	Pkt 10rd
P2-FRMB32B/10	3.2mm Bare	Pkt 10rd
P2-FRMB32F/10	3.2mm Flux Coated	Pkt 10rd

BRAZING ROD NICKEL BRONZE

- High strength joining of steel, cast iron and malleable iron
- Also used for: Fusion welding similar copper alloys, brazing nickel based alloys
- Also known as Nickel-Silver
- Wear resistant brazing build up of worn components



Part No.	Description	Unit
P2-FRNS24F/10	2.4mm Flux Coated	Pkt 10rd
P2-FRNS32F/8	3.2mm Flux Coated	Pkt 8rd



MIG TORCHES & SPARES



A quick look at...



MIG TORCHES



No Quality Short-cuts!

Quality control & design managed by European based industry leaders with over 40 years of experience in Torch manufacturing.

High Quality Cables

Maximum flexibility with excellent heat & abrasion resistance

Attention to Detail = Reliability

We pay attention to the little things that can make or break a MIG Torch: Integrity of Cable Crimps, Switch Design, quality of Raw Materials/Components, etc.

Often it's what you can't physically see that has the greatest impact on reliability & productivity.



MIG TORCHES PROMAX 15 (BINZEL 15 STYLE)



- European Style and Design
- Designed for Reliability, Easy Maintenance and Reduced Down-Time
- Advanced Handle Design: Ergonomic & Lightweight
- Screwless Quick-Change Handle & Trigger = Change trigger and handle parts without tools
- Knuckle Joint at handle for improved manoeuvrability
- High Quality Cables for Maximum Flexibility, Heat and Abrasion Resistance

APPLICATION INFO:

- 180 Amp Maximum Capacity (150A @ 60% duty cycle, using mixed argon gas)
- Heavy duty torch suitable for production welding
- Euro connection - fits most common brands/models of MIG welders / wire feeders

Part No.	Description	Unit
WC-03609	3m	Each
WC-03610	4m	Each

The products advertised above are original Weldclass products only. Weldclass is not affiliated in any way with Binzel, and the products are not original Binzel. Any references to Binzel trade names and/or part numbers are for identification purposes only.

MIG TORCHES PROMAX 24 (BINZEL 24 STYLE)



- European Style and Design
- Designed for Reliability, Easy Maintenance and Reduced Down-Time
- Advanced Handle Design: Ergonomic & Lightweight
- Screwless Quick-Change Handle & Trigger = Change trigger and handle parts without tools
- Knuckle Joint at handle for improved manoeuvrability
- High Quality Cables for Maximum Flexibility, Heat and Abrasion Resistance

APPLICATION INFO:

- 240 Amp Maximum Capacity (220A @ 60% duty cycle, using mixed argon gas)
- Heavy duty torch suitable for production welding
- Euro connection - fits most common brands/models of MIG welders / wire feeders

Part No.	Description	Unit
WC-03611	3m	Each
WC-03612	4m	Each

The products advertised above are original Weldclass products only. Weldclass is not affiliated in any way with Binzel, and the products are not original Binzel. Any references to Binzel trade names and/or part numbers are for identification purposes only.



MIG TORCHES PROMAX 25 (BINZEL 25 STYLE)



- European Style and Design
- Designed for Reliability, Easy Maintenance and Reduced Down-Time
- Advanced Handle Design: Ergonomic & Lightweight
- Screwless Quick-Change Handle & Trigger = Change trigger and handle parts without tools
- Knuckle Joint at handle for improved manoeuvrability
- High Quality Cables for Maximum Flexibility, Heat and Abrasion Resistance

APPLICATION INFO:

- 230 Amp Maximum Capacity (200A @ 60% duty cycle, using mixed argon gas)
- Heavy duty torch suitable for production welding
- Euro connection - fits most common brands/models of MIG welders / wire feeders

Part No.	Description	Unit
WC-03614	3m	Each
WC-03615	4m	Each

The products advertised above are original Weldclass products only. Weldclass is not affiliated in any way with Binzel, and the products are not original Binzel. Any references to Binzel trade names and/or part numbers are for identification purposes only.

MIG TORCHES PROMAX 36 (BINZEL 36 STYLE)



- European Style and Design
- Designed for Reliability, Easy Maintenance and Reduced Down-Time
- Advanced Handle Design: Ergonomic & Lightweight
- Screwless Quick-Change Handle & Trigger = Change trigger and handle parts without tools
- Knuckle Joint at handle for improved manoeuvrability
- High Quality Cables for Maximum Flexibility, Heat and Abrasion Resistance

APPLICATION INFO:

- 320 Amp Maximum Capacity (270A @ 60% duty cycle, using mixed argon gas)
- Heavy duty torch suitable for production welding
- Euro connection - fits most common brands/models of MIG welders / wire feeders

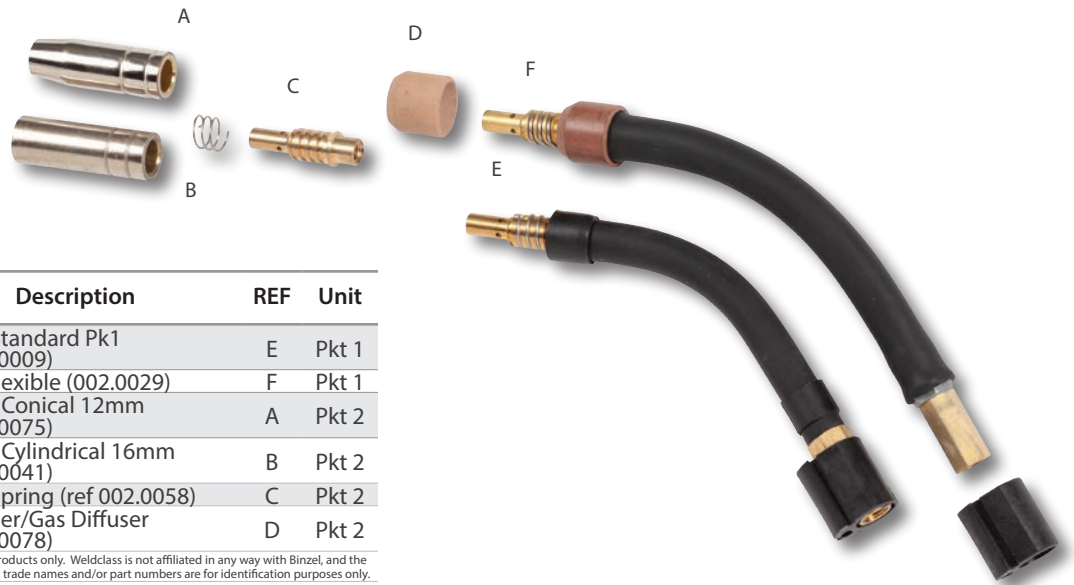
Part No.	Description	Unit
WC-03617	3m	Each
WC-03618	4m	Each
WC-03619	5m	Each

The products advertised above are original Weldclass products only. Weldclass is not affiliated in any way with Binzel, and the products are not original Binzel. Any references to Binzel trade names and/or part numbers are for identification purposes only.



MIG TORCH SPARES BZL 15 STYLE

- Suit Binzel 15 (MB 15) style MIG torches
- For Contact Tips, refer to "MIG Tips BZL Style M6x6"

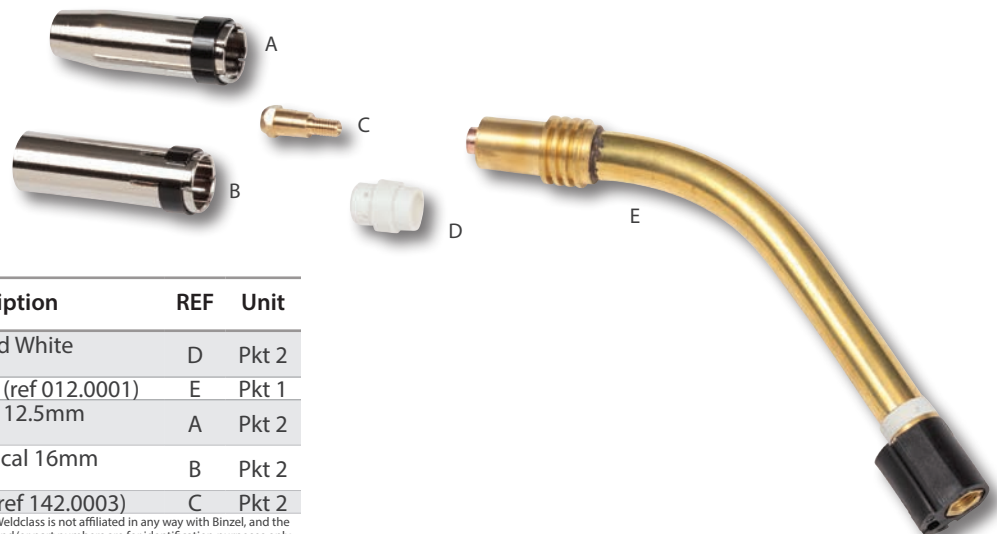


Part No.	Description	REF	Unit
P3-B15SN	Neck - Standard Pk1 (ref 002.0009)	E	Pkt 1
P3-B15FN	Neck - Flexible (002.0029)	F	Pkt 1
P3-B15N	Nozzle - Conical 12mm (ref 145.0075)	A	Pkt 2
P3-B15NC	Nozzle - Cylindrical 16mm (ref 145.0041)	B	Pkt 2
P3-B15NS	Nozzle Spring (ref 002.0058)	C	Pkt 2
P3-B15TH	Tip Holder/Gas Diffuser (ref 002.0078)	D	Pkt 2

The products advertised above are original Weldclass products only. Weldclass is not affiliated in any way with Binzel, and the products are not original Binzel. Any references to Binzel trade names and/or part numbers are for identification purposes only.

MIG TORCH SPARES BZL 24 STYLE

- Suit Binzel 24 (MB 24) style MIG torches
- For Contact Tips, refer to "MIG Tips BZL Style M6x6" & "MIG Tips BZL Style M6x8"



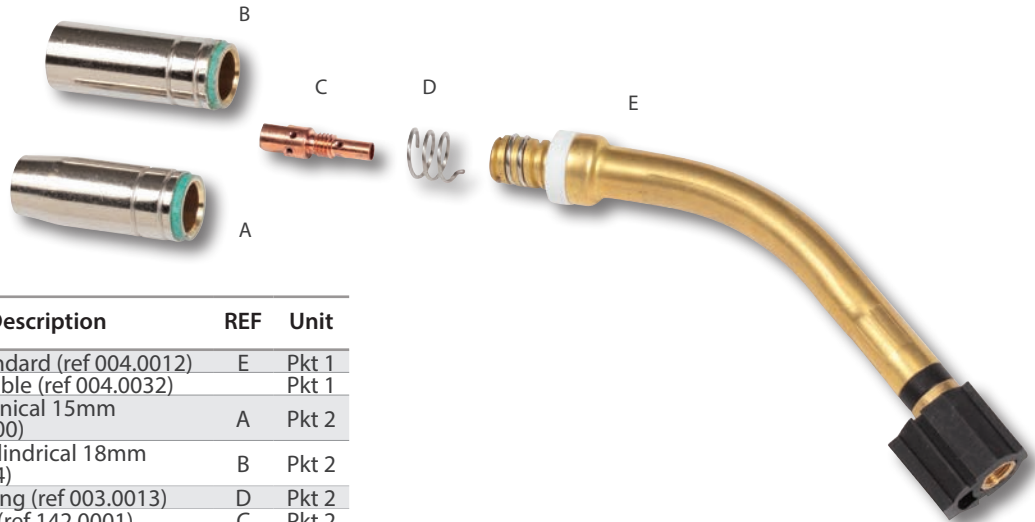
Part No.	Description	REF	Unit
P3-B24GD	Gas Diffuser - Std White (ref 012.0183)	D	Pkt 2
P3-B24SN	Neck - Standard (ref 012.0001)	E	Pkt 1
P3-B24N	Nozzle - Conical 12.5mm (ref 145.0080)	A	Pkt 2
P3-B24NC	Nozzle - Cylindrical 16mm (ref 145.0047)	B	Pkt 2
P3-B24TH	Tip Holder Pk2 (ref 142.0003)	C	Pkt 2

The products advertised above are original Weldclass products only. Weldclass is not affiliated in any way with Binzel, and the products are not original Binzel. Any references to Binzel trade names and/or part numbers are for identification purposes only.



MIG TORCH SPARES BZL 25 STYLE

- Suit Binzel 25 (MB 25) style MIG torches
- For Contact Tips, refer to "MIG Tips BZL Style M6x6" & "MIG Tips BZL Style M6x8"

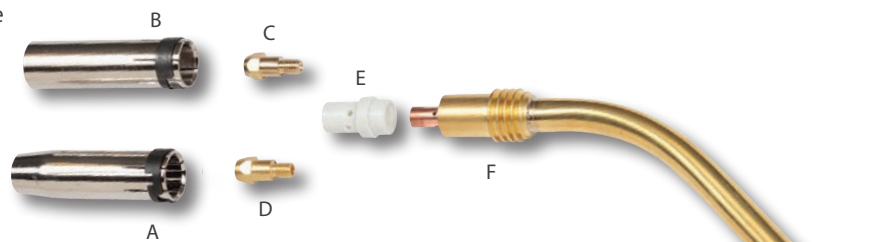


Part No.	Description	REF	Unit
P3-B25SN	Neck - Standard (ref 004.0012)	E	Pkt 1
P3-B25FN	Neck - Flexible (ref 004.0032)		Pkt 1
P3-B25N	Nozzle - Conical 15mm (ref 145.0100)	A	Pkt 2
P3-B25NC	Nozzle - Cylindrical 18mm (ref 145.004)	B	Pkt 2
P3-B25NS	Nozzle Spring (ref 003.0013)	D	Pkt 2
P3-B25TH	Tip Holder (ref 142.0001)	C	Pkt 2

The products advertised above are original Weldclass products only. Weldclass is not affiliated in any way with Binzel, and the products are not original Binzel. Any references to Binzel trade names and/or part numbers are for identification purposes only.

MIG TORCH SPARES BZL 36 STYLE

- Suit Binzel 36 (MB 36) style MIG torches
- For Contact Tips, refer to "MIG Tips BZL Style M6x8" & "MIG Tips BZL Style M8x10"



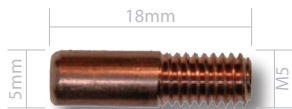
Part No.	Description	REF	Unit
P3-B36GD	Gas Diffuser Std White (ref 014.0261)	E	Pkt 2
P3-B36SN	Neck - Standard (ref 014.0006)	F	Pkt 1
P3-B36N	Nozzle - Conical 16mm (ref 145.0078)	A	Pkt 2
P3-B36NC	Nozzle - Cylindrical 18mm (ref 145.0045)	B	Pkt 2
P3-B36TH6	Tip Holder - For M6 Tips (ref 142.0005)	C	Pkt 2
P3-B36TH8	Tip Holder - For M8 Tips (ref 142.0020)	D	Pkt 2

The products advertised above are original Weldclass products only. Weldclass is not affiliated in any way with Binzel, and the products are not original Binzel. Any references to Binzel trade names and/or part numbers are for identification purposes only.



MIG TIPS BZL STYLE M5X5

- Quality Contact Tips suit various small MIG torches
- M5 (5mm) thread & 5mm body

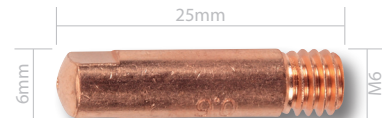


Part No.	Description	Unit
P3-BT508	0.8mm (ref 140.0037)	Pkt 5
P3-BT509	0.9mm (ref 140.0164)	Pkt 5

The products advertised above are original Weldclass products only. Weldclass is not affiliated in any way with Binzel, and the products are not original Binzel. Any references to Binzel trade names and/or part numbers are for identification purposes only.

MIG TIPS BZL STYLE M6X6

- Binzel style contact tips suitable for 15, 24 & 25 style MIG torches.
- M6 (6mm) Thread and 6mm Body



Part No.	Description	Unit
P3-BT6066	0.6mm (ref 140.0008)	Pkt 5
P3-BT6086	0.8mm (ref 140.0059)	Pkt 5
P3-BT6096	0.9mm (ref 140.0177)	Pkt 5
P3-BTA6096	0.9mm Alu/Flux-Core (ref 141.0005)	Pkt 5

The products advertised above are original Weldclass products only. Weldclass is not affiliated in any way with Binzel, and the products are not original Binzel. Any references to Binzel trade names and/or part numbers are for identification purposes only.

MIG TIPS BZL STYLE M6X8

- Binzel style contact tips suit MB 24, 25, 26, 36 style MIG torches
- M6 (6mm) Thread & 8mm Body



Part No.	Description	Unit
P3-BT609	0.9mm (ref 140.0169)	Pkt 5
P3-BTA609	0.9mm Alu/Flux-Core (ref 141.0004)	Pkt 5
P3-BT610	1.0mm (ref 140.0242)	Pkt 5
P3-BTA610	1.0mm Alu (ref 141.0006)	Pkt 5
P3-BT612	1.2mm (ref 140.0379)	Pkt 5
P3-BTA612	1.2mm Alu/Flux-Core (ref 141.0072)	Pkt 5
P3-BT616	1.6mm (ref 140.0555)	Pkt 5

The products advertised above are original Weldclass products only. Weldclass is not affiliated in any way with Binzel, and the products are not original Binzel. Any references to Binzel trade names and/or part numbers are for identification purposes only.

MIG TIPS BZL STYLE M8X10

- Binzel style contact tips suitable for MB 36, 38 & 501 style MIG torches
- M8 (8mm) Thread & 10mm Body

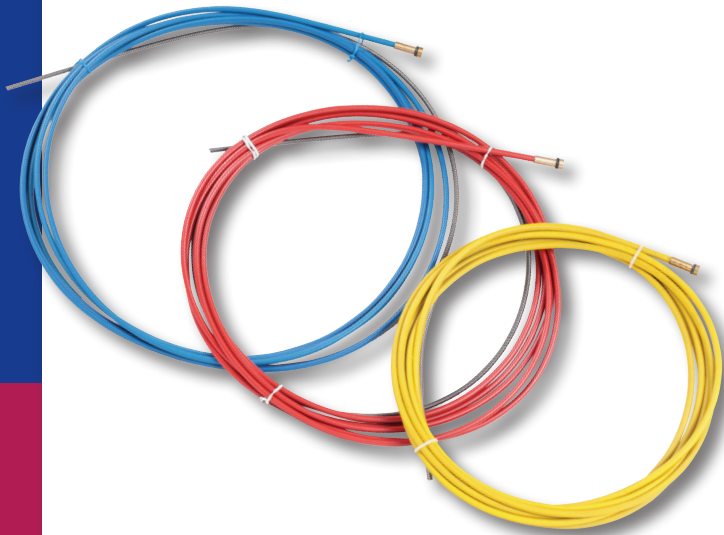


Part No.	Description	Unit
P3-BT809	0.9mm (ref 140.0214)	Pkt 5
P3-BT810	1.0mm (ref 140.0313)	Pkt 5
P3-BT812	1.2mm (ref 140.0442)	Pkt 5
P3-BTA812	1.2mm Alu/Flux-Core (ref 141.0015)	Pkt 5
P3-BT816	1.6mm (ref 140.0587)	Pkt 5

The products advertised above are original Weldclass products only. Weldclass is not affiliated in any way with Binzel, and the products are not original Binzel. Any references to Binzel trade names and/or part numbers are for identification purposes only.



MIG LINERS BZL STYLE



- Suit Binzel Style MIG Torches
- For 0.6mm-0.8mm Steel Wire

Note: For Teflon/Aluminium Liners, see end of this section

Part No.	Description	Unit
WC-00391	0.9 - 1.2mm Red 3m (ref 124.0026)	Pkt 1
WC-00393	0.9 - 1.2mm Red 4m (ref 124.0031)	Pkt 1
WC-00395	0.9 - 1.2mm Red 5m (ref 124.0035)	Pkt 1
WC-03340	0.9 - 1.2mm Red 11m	Each
WC-00397	1.2 - 1.6mm Yellow 3m (ref 124.0041)	Pkt 1
WC-00399	1.2 - 1.6mm Yellow 4m (ref 124.0042)	Pkt 1
WC-00401	1.2 - 1.6mm Yellow 5m (ref 124.0044)	Pkt 1

The products advertised above are original Weldclass products only. Weldclass is not affiliated in any way with Binzel, and the products are not original Binzel. Any references to Binzel trade names and/or part numbers are for identification purposes only.

Why choose...

WELDCLASS MIG TORCH SPARES

- **No Quality Short-cuts**
- **Long-life parts that reduce down-time, cuts costs & increase productivity**
- **Quality packaging & handy quantities for individual portion control**



MIG TORCH SPARES BZL STYLE - MISC



Part No.	Description	Unit
WC-04710	Trigger - Suit Promax BZL Torch	Each
WC-03803	Handle & Lock Nut - Suit Promax BZL Torch	Each

The products advertised above are original Weldclass products only. Weldclass is not affiliated in any way with Binzel, and the products are not original Binzel. Any references to Binzel trade names and/or part numbers are for identification purposes only.



MIG TORCH PROMAX TWC 1 (MAGNUM 100L / TWECO 1 STYLE)

- Connection to suit Lincoln Power Mig 180C / SP-170T Small MIG Welders
- Light duty Gas/ Gasless Torch



Part No.	Description	Unit
WC-03957	3m	Each

The products advertised above are original Weldclass products only. Weldclass is not affiliated in any way with Tweco, and the products are not original Tweco. Any references to Tweco trade names and/or part numbers are for identification purposes only.

MIG TORCHES PROMAX TWC 2 (TWECO 2 STYLE)

- Tweco 2 style 250 Amp MIG torch, for Medium Fabrication
- Euro Connection suits most modern MIG welders
- Robust Design withstands Heavy Duty Use



Part No.	Description	Unit
3-MTT2E/12	Euro Fitting 3.5m (12ft)	Each
3-MTT2E/15	Euro Fitting 4.6m (15ft)	Each

The products advertised above are original Weldclass products only. Weldclass is not affiliated in any way with Tweco, and the products are not original Tweco. Any references to Tweco trade names and/or part numbers are for identification purposes only.



MIG TORCHES PROMAX TWC 4 (TWECO 4 STYLE)

- Tweco 4 style 400 Amp MIG torch
- For Medium to Heavy Fabrication & Production Welding at high duty cycles
- Euro Connection suits most modern MIG welders or Bayonet Connection to suit some older machines
- Robust Design withstands Heavy Duty Use



Bayonet Connection

Euro Connection

Part No.	Description	Unit
3-MTT4E/12	Euro Fitting 3.5m (12ft)	Each
3-MTT4E/15	Euro Fitting 4.5m (15ft)	Each
3-MTT4B/12	Bayonet Fitting 3.5m (12ft)	Each
3-MTT4B/15	Bayonet Fitting 4.5m (15ft)	Each

The products advertised above are original Weldclass products only. Weldclass is not affiliated in any way with Tweco, and the products are not original Tweco. Any references to Tweco trade names and/or part numbers are for identification purposes only.



MIG TORCH SPARES TWC 1 / MAGNUM 100L STYLE

- Suit Tweco 1 & Lincoln Magnum 100L style MIG torches



Part No.	Description	REF	Unit
P3-170GD	Gas Diffuser Suit Magnum 100L (ref 35-50)	C	Pkt 2
P3-51	Gas Diffuser Suit TWC1 (ref 51)	D	Pkt 2
P3-454015	Liner - Steel 0.9 - 1.2mm (ref 45-40-15)	E	Pkt 1
P3-2150	Nozzle - Conical 13mm (ref 21-50)	A	Pkt 2
P3-170GN	Nozzle - Gasless (ref KP1939-1)	B	Pkt 2

The products advertised above are original Weldclass products only. Weldclass is not affiliated in any way with Tweco, and the products are not original Tweco. Any references to Tweco trade names and/or part numbers are for identification purposes only.

MIG TORCH SPARES TWC 2 STYLE

- Suit Tweco 2 style MIG torches
- For Contact Tips, refer to "MIG Tips TWC 2/4 Style"



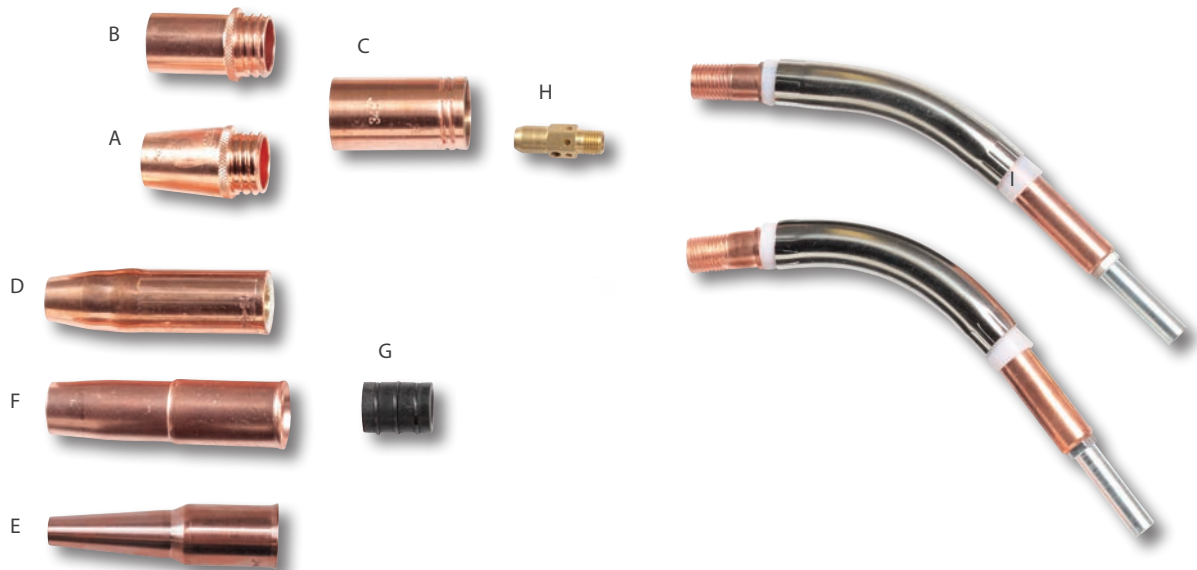
Part No.	Description	REF	Unit
P3-T2HDGD	Gas Diffuser - Fits TWC2, Takes TWC4 Parts (52FN)	D	Pkt 2
P3-52	Gas Diffuser Std (ref 52)	E	Pkt 2
P3-32	Insulator - Black (ref 32)	C	Pkt 2
P3-42303515	Liner - Steel 0.8 - 0.9mm (ref 42-3035-15)	F	Pkt 1
P3-42404515	Liner - Steel 0.9 - 1.2mm (ref 42-4045-15)	F	Pkt 1
P3-2250	Nozzle - Conical 12mm (ref 22-50)	A	Pkt 2
P3-2262	Nozzle - Straight 16mm (ref 22-62)	B	Pkt 2

The products advertised above are original Weldclass products only. Weldclass is not affiliated in any way with Tweco, and the products are not original Tweco. Any references to Tweco trade names and/or part numbers are for identification purposes only.



MIG TORCH SPARES TWC 4 STYLE

- Suit Tweco 4 style MIG torches
- For Contact Tips, refer to "MIG Tips TWC 2/4 Style"



Part No.	Description	REF	Unit
P3-54A	Gas Diffuser / Tip Holder (ref 54A)	H	Pkt 2
WC-TW84A	Handle & Cable Support	N/L	Each
P3-34CT	Insulator H/Duty Copper (ref 34CT)	C	Pkt 2
P3-34A	Insulator Std Black (ref 34A)	G	Pkt 2
P3-44354515	Liner - Steel 0.9-1.2mm (ref 44-3545-15)	M	Pkt 1
P3-4411615	Liner - Steel 1.2-1.6mm (ref 44-116-15)	M	Pkt 1
P3-4456415	Liner - Steel 1.6-2.0mm (ref 44-564-15)	M	Pkt 1
P3-64A45HD	Neck H/Duty 45DG Pk1 (ref 64A-45J)	J	Pkt 1
P3-64A60HD	Neck H/Duty 60DG Pk 1 (ref 64A-60J)	I	Pkt 1
P3-24CT62S	Nozzle H/Duty Conical 16mm (ref 24CT-62S)	A	Pkt 2
P3-24CT75S	Nozzle H/Duty Straight 20mm (ref 24CT-75S)	B	Pkt 2
P3-2350	Nozzle Self-Insulated 13mm (ref 23-50)	D	Pkt 2
P3-24A62	Nozzle Std Push-On Conical 16mm (ref 24A-62)	F	Pkt 2
P3-24A75	Nozzle Std Push-On Straight 20mm (ref 24A-75)		Pkt 2
WC-TW24AT37SSP	Nozzle Std Push-On Tapered 10mm (ref 24AT-37SSP)	E	Pkt2
WC-TW94R	Trigger Switch	K	Each



The products advertised above are original Weldclass products only. Weldclass is not affiliated in any way with Tweco, and the products are not original Tweco. Any references to Tweco trade names and/or part numbers are for identification purposes only.



MIG TIPS TWC 1 STYLE

- Suit Tweco 1 & Lincoln Magnum 100L style MIG torches



Part No.	Description	Unit
P3-1123	Contact Tip 0.6mm (ref 11-23)	Pkt 5
P3-1130	Contact Tip 0.8mm (ref 11-30)	Pkt 5
P3-1135	Contact Tip 0.9mm (ref 11-35)	Pkt 5
P3-1140	Contact Tip 1.0mm (ref 11-40)	Pkt 5
P3-1145	Contact Tip 1.2mm (ref 11-45)	Pkt 5

The products advertised above are original Weldclass products only. Weldclass is not affiliated in any way with Tweco, and the products are not original Tweco. Any references to Tweco trade names and/or part numbers are for identification purposes only.



MIG TIPS TWC 2/4 STYLE

- Quality contact tips for Tweco 2 & 4 style MIG torches
- Heavy Duty Style with Thicker Body for Longer Life



Part No.	Description	Unit
P3-1430	Contact Tip Std 0.8mm (ref 14-30)	Pkt 5
P3-14H35	Contact Tip H/D 0.9mm (ref 14H-35)	Pkt 5
P3-14H40	Contact Tip H/D 1.0mm (ref 14H-40)	Pkt 5
P3-14H45	Contact Tip H/D 1.2mm (ref 14H-45)	Pkt 5
P3-14H52	Contact Tip H/D 1.2mm Alu/Flux-Core (14H-52)	Pkt 5
P3-14H116	Contact Tip H/D 1.6mm (ref 14H-116)	Pkt 5

The products advertised above are original Weldclass products only. Weldclass is not affiliated in any way with Tweco, and the products are not original Tweco. Any references to Tweco trade names and/or part numbers are for identification purposes only.

MIG TIPS TWC 2/4 STYLE - TAPERED

- Quality contact tips for Tweco 2 & 4 style MIG torches
- Tapered ("pipeline") style



Part No.	Description	Unit
WC-TW14T35P	Contact Tip Tapered 0.9mm (ref 14T-35)	Pkt 5
WC-TW14T40P	Contact Tip Tapered 1.0mm (ref 14T-40)	Pkt 5
WC-TW14T45P	Contact Tip Tapered 1.2mm (ref 14T-45)	Pkt 5
WC-TW14T52P	Contact Tip Tapered 1.3mm (ref 14T-52)	Pkt 5
WC-TW14T116P	Contact Tip Tapered 1.6mm (ref 14T-116)	Pkt 5

The products advertised above are original Weldclass products only. Weldclass is not affiliated in any way with Tweco, and the products are not original Tweco. Any references to Tweco trade names and/or part numbers are for identification purposes only.



MIG TORCHES BND 300 STYLE

- Bernard style 300 Amp MIG torch
- For Medium to Heavy Fabrication & Production Welding at high duty cycles
- Euro Connection suits most modern MIG welders or BND/EZ/QD Connection to suit some older WIA machines
- Robust Design withstand Heavy Duty Use



Euro Connection



BND/EZ/QD Connection

Part No.	Description	Unit
3-MTBN3E/12	Euro Connection 3.6m (12ft)	Each
3-MTBN3E/15	Euro Connection 4.6m (15ft)	Each
3-MTBN3B/12	BND/EZ/QD Connection 3.6m (12ft)	Each
3-MTBN3B/15	BND/EZ/QD Connection 4.6m (15ft)	Each

The products advertised above are original Weldclass products only. Weldclass is not affiliated in any way with Bernard, and the products are not original Bernard. Any references to Bernard trade names and/or part numbers are for identification purposes only.

MIG TORCHES BND 400 STYLE

- Bernard style 400 Amp MIG torch
- For Heavy Fabrication & Production Welding at high duty cycles
- Euro Connection suits most modern MIG welders or BND/EZ/QD Connection to suit some older WIA machines
- Robust Design withstand Heavy Duty Use



Euro Connection



BND/EZ/QD Connection

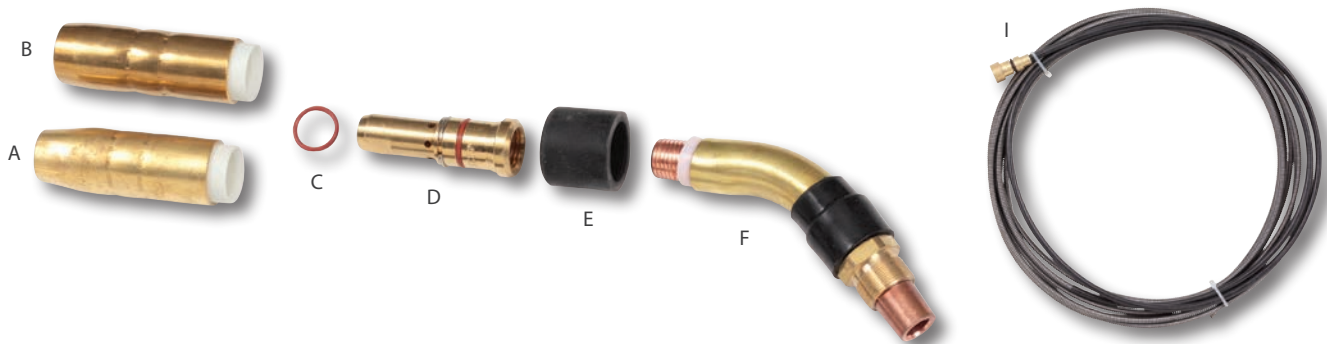
Part No.	Description	Unit
3-MTBN4E/12	Euro Connection 3.6m (12ft)	Each
3-MTBN4E/15	Euro Connection 4.6m (15ft)	Each
3-MTBN4B/12	BND/EZ/QD Connection 3.6m (12ft)	Each
3-MTBN4B/15	BND/EZ/QD Connection 4.6m (15ft)	Each

The products advertised above are original Weldclass products only. Weldclass is not affiliated in any way with Bernard, and the products are not original Bernard. Any references to Bernard trade names and/or part numbers are for identification purposes only.



MIG TORCH SPARES BND 300 STYLE

- Suit Bernard style 400A MIG torches
- For Contact Tips, refer to "MIG Tips BND 300/400 Style"



Part No.	Description	REF	Unit
WC-BE4323P	Cap - Rubber (ref BE4323)	E	Pkt 2
3-1780006	Handle Set	G	Each
P3-43115	Liner - Steel 0.9-1.2mm (ref 43115)	I	Pkt 1
P3-43215	Liner - Steel 1.2-1.6mm (ref 43215)	I	Pkt 1
P3-4786	Neck / Body Tube (ref BE4786)	F	Pkt 1
P3-4392	Nozzle 13mm (ref BE4392)	A	Pkt 2
P3-4391	Nozzle 16mm (ref BE4391)	B	Pkt 2
WC-BE7126P	O-Ring for Head Assy (ref BE7126)	C	Pkt 2
WC-BE4335P	Tip Holder / Head Assy (ref BE4335)	D	Pkt 2
3-5662	Trigger	H	Each



The products advertised above are original Weldclass products only. Weldclass is not affiliated in any way with Bernard, and the products are not original Bernard. Any references to Bernard trade names and/or part numbers are for identification purposes only.



World's Best Vision...

See Page 108



MIG TORCH SPARES BND 400 STYLE

- Suit Bernard style 400A MIG torches
- For Contact Tips, refer to "MIG Tips BND 300/400 Style"

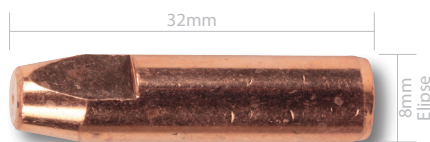


Part No.	Description	REF	Unit
WC-BE4423P	Cap - Rubber (ref BE4423)	E	Pkt 2
3-1780006	Handle Set (>2015 Model)	G	Pkt 1
P3-44115	Liner - Steel 0.9-1.2mm (ref 44115)	I	Pkt 1
P3-4790	Neck / Body Tube (ref BE4790)	F	Pkt 1
P3-4492	Nozzle 14mm (ref BE4492)	A	Pkt 2
P3-4491	Nozzle 19mm (ref BE4491)	B	Pkt 2
WC-BE7127P	O-Ring for Head Assy (ref BE7127)	C	Pkt 2
WC-BE4435P	Tip Holder / Head Assy (ref BE4435)	D	Pkt 2
3-5662	Trigger (>2015 Model)	H	Each

The products advertised above are original Weldclass products only. Weldclass is not affiliated in any way with Bernard, and the products are not original Bernard. Any references to Bernard trade names and/or part numbers are for identification purposes only.

MIG TIPS BND 300/400 STYLE

- Bernard style Contact Tips suit 300A & 400A torches
- Twist-Lock Style



Part No.	Description	Unit
P3-7488	Contact Tip 0.8mm (ref BE7488)	Pkt 5
P3-7489	Contact Tip 0.9mm (ref BE7489)	Pkt 5
P3-7496	Contact Tip 1.0mm (ref BE7496)	Pkt 5
P3-7490	Contact Tip 1.2mm (ref BE7490)	Pkt 5
P3-7498	Contact Tip 1.2mm Alu/Flux-Core (ref 7498)	Pkt 5
P3-7491	Contact Tip 1.6mm (ref BE7491)	Pkt 5

The products advertised above are original Weldclass products only. Weldclass is not affiliated in any way with Bernard, and the products are not original Bernard. Any references to Bernard trade names and/or part numbers are for identification purposes only.



TEFLON LINERS FOR ALUMINIUM UNIVERSAL SERIES

- For Aluminium Wire
- Suits almost any MIG torch: Supplied with fittings to suits all common torch connections: Binzel/Euro, Tweco/ Bayonet & Bernard/QD/EZ.
- Made from Graphite ('Carbon-Teflon') material: Much harder than standard Teflon providing longer wear life and smoother wire-feeding
- Supplied with Brass Neck Liner
- Suits all lengths of MIG torches up to 5m: Simply cut to correct length



Many liners in one - Save time & hassle! Long lasting Carbon-Teflon material.

Part No.	Description	Unit
P3-CTUL09	For 0.9/1.0/1.2mm Aluminium Wire Suit Torches up to 5m Long	Each
P3-CTUL12	For 1.2/1.6mm Aluminium Wire Suit Torches up to 5m Long	Each

TEFLON LINERS FOR ALUMINIUM SUIT LONG TORCHES

- For Aluminium Wire
- Suit Torches with Euro Style Connection
- Suitable for Torches up to 10m Long, especially Push-Pull Torches
- Made from Graphite ('Carbon-Teflon') style material: Much harder than standard Teflon providing longer wear life and smoother wire-feeding
- Supplied with Brass Neck Liner



Ideal for Push-Pull Torches!

Part No.	Description	Unit
P3-CTL09/11	For 0.9/1.0/1.2mm Aluminium Wire Suit Torches up to 10m Long	Each
P3-CTL12/11	For 1.2/1.6mm Aluminium Wire Suit Torches up to 10m Long	Each



EURO CONNECTOR KIT & PARTS

- Kits & components to suit common Euro-style MIG torch connections



Part No.	Description	Unit
3-BGAK	Euro Connector Kit (For Front of Welding Machine)	Kit
3-BBGT	Guide Tube - For Steel Wire	Each
WC-02434	O-Ring for Euro Gas Nipple	Each
3-BPH	Plastic Housing	Each
3-BTB	Threaded Rod	Each



NECK LINERS

- Brass Neck Liners to suit Teflon and Carbon Teflon Liners

Part No.	Description	Unit
3-BNL	Neck Liner (Brass) Suit 0.9-1.2mm Liner	Each
3-BNL12	Neck Liner (Brass) Suit 1.2-1.6mm Liner	Each



TIG TORCHES & SPARES

A quick look at...

Weldclass Promax 'UNIVERSAL SERIES' TIG TORCHES

Not quite sure what TIG Torch fits your machine? Or what type of Torch head you prefer? No problem! The Promax Universal TIG Torch range offer an All-in-one package that saves hassle, time & money...

Includes a range of rigid & flexible Torch heads

Modern ergonomic handle with ball joint for easy handling of Torch

Includes parts kits & tungsten electrodes 'ready to weld'

Includes small & large connectors to fit most welders*

*2-pc style torches only

Many Torch options in one Package!

See following pages



TIG TORCHES PROMAX UNIVERSAL SERIES 9/17 - WITH VALVE 2PC

- All-In-One TIG Torch - Multiple Options in One Package
- Save Time, Hassle & Money
- Modern Ergonomic Handle with Ball Joint to allow easy handling of the torch

INCLUDES:

- Torch Heads - Includes: 17 series (150 amp) & 9 Series (100 amp), in both Rigid & Flexible
- Valved style heads for use with most standard inverter welders
- 2 Piece style Cable - Includes Small & Large Cable Connectors, to fit to most welders
- Parts kits & tungsten electrodes "ready to weld"
- Protective Cable Sheath Fitted



INDICATIVE PRICE
3-TTU2917V/4

\$185⁰⁰ Excl GST*

For your nearest Distributor
Phone 1300 784 200

*Prices are indicative only and may vary depending on volumes, freight cost, models/options & other factors

Part No.	Description	Unit
3-TTU2917V/4	Torch Kit 4m C/w: 9V/9FV/17V/17FV Heads & 1025/3550 Connectors	Each
3-TTU2917V/8	Torch Kit 8m C/w: 9V/9FV/17V/17FV Heads & 1025/3550 Connectors	Each

TIG TORCHES PROMAX UNIVERSAL SERIES 26 - WITH VALVE 2PC

- All-In-One TIG Torch - Multiple Options in One Package
- Save Time, Hassle & Money
- Modern Ergonomic Handle with Ball Joint to allow easy handling of the torch

INCLUDES:

- Torch Heads - Includes: 26 series (200amp), in both Rigid & Flexible
- Valved style heads for use with most standard inverter welders
- 2 Piece style Cable - Includes Small & Large Cable Connectors, to fit to most welders
- Parts kits & tungsten electrodes "ready to weld"
- Protective Cable Sheath Fitted



Part No.	Description	Unit
3-TTU226V/4	Torch Kit 4m C/w: 26V/26FV Heads & 1025/3550 Connectors	Each
3-TTU226V/8	Torch Kit 8m C/w: 26V/26FV Heads & 1025/3550 Connectors	Each

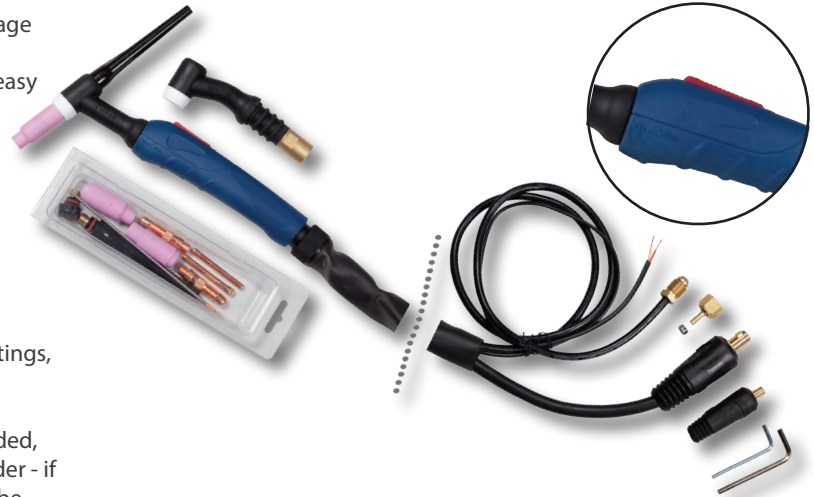


TIG TORCHES PROMAX UNIVERSAL SERIES WITH SWITCH

- All-In-One TIG Torch - Multiple Options in One Package
- Save Time, Hassle & Money
- Modern Ergonomic Handle with Ball Joint to allow easy handling of the torch

INCLUDES:

- Torch Heads - Rigid & Flexible
- Fitted with Trigger Switch (on/off) for use with TIG welders that have a trigger function
- Connectors - Includes Small 10-25 & Large 35-50 Connectors, to fit to most welders
- Parts kits & tungsten electrodes "ready to weld"
- Gas connection: Includes male & female 5/8 UNF fittings, to fit to welding machine
- Trigger Connection: Trigger wires fitted & ready to connect to electrical plug (electrical plug not included, this will be specific to the model & make of the welder - if replacing an old torch, the old plug may be able to be used)
- 2 Piece style Cable
- Protective Cable Sheath Fitted



Part No.	Description	Unit
3-TTU217T/4	17 ((150AMP) Torch Kit 4M	Each
3-TTU226T/4	26 (200AMP) Torch Kit 4M	Each
3-TTU226T/8	26 (200AMP) Torch Kit 8M	Each

TIG TUNGSTENS RE4 (RARE-EARTH STYLE) AC/DC

- "All metal" Tungsten Suitable for DC & AC TIG welding
- For DC welding of mild steel, stainless steel, copper and chrome molly
- For AC TIG welding of: Aluminium alloys and Aluminium bronze
- Does Not contain radioactive elements = No special safeguards required for use, storage or transport
- Maintains tip geometry, Reliable arc striking, Low burn off rate, Long service life and Smooth/stable arc
- Contains additives/combinations of "rare-earth" oxides, scientifically balanced to provide optimum arc characteristics and wear life
- Compared to other tungsten formulas: Requires less energy to start, Runs cooler, Greater longevity, Greater current capacity (ability to use a smaller-diameter electrode for the same job or use higher current for a similar-sized electrode)

The high performance and hazard-free "all-metal" tungsten!



Part No.	Description	Unit
WC-05192	1.6mm Purple Tip	Pkt 10
WC-05193	2.4mm Purple Tip	Pkt 10
WC-05194	3.2mm Purple Tip	Pkt 10

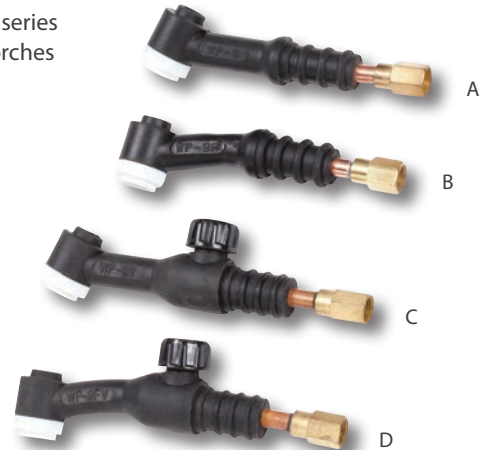


TIG PARTS DIAGRAM 9/20 SERIES



TIG TORCH BODIES 9 SERIES

- Suit 9 series TIG torches



Part No.	Description	REF	Unit
P3-TB9	9 Standard (No Valve)	A	Pkt 1
P3-TB9F	9F Flexible (No Valve)	B	Pkt 1
P3-TB9V	9V Valved	C	Pkt 1
P3-TB9FV	9FV Flexible Valved	D	Pkt 1

TIP BACK CAPS 9/20 SERIES

- Suit 9 & 20 series TIG torches

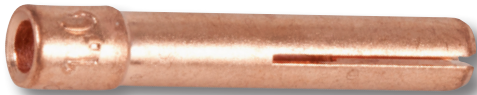


Part No.	Description	REF	Unit
WC-41V24P	Long (ref 41V24)	A	Pkt 2
WC-41V35P	Medium (ref 41V35)	B	Pkt 2
WC-41V33P	Short (ref 41V33)	C	Pkt 2



TIG COLLETS 9/20 SERIES

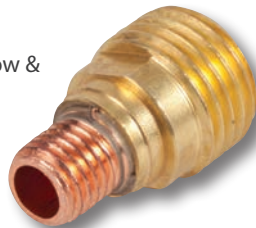
- Suit 9 & 20 series TIG torches



Part No.	Description	Unit
P3-13N22	1.6mm (ref 13N22)	Pkt 2
P3-13N23	2.4mm (ref 13N23)	Pkt 2
P3-13N24	3.2mm (ref 13N24)	Pkt 2

TIG 'GAS LENS' COLLET BODIES 9/20 SERIES

- Suits 9 & 20 series TIG torches
- Gas Lens style, for smooth gas flow & even gas shield



Part No.	Description	Unit
WC-45V43P	1.6mm (ref 45V43)	Pkt 2
WC-45V44P	2.4mm (ref 45V44)	Pkt 2
WC-45V45P	3.2mm (ref 45V45)	Pkt 2

TIG COLLET BODIES 9/20 SERIES

- Suits 9 & 20 series TIG torches



Part No.	Description	Unit
P3-13N27	1.6mm (ref 13N27)	Pkt 2
P3-13N28	2.4mm (ref 13N28)	Pkt 2
P3-13N29	3.2mm (ref 13N29)	Pkt 2

TIG CERAMIC 'GAS LENS' CUPS 9/20 SERIES

- Suits 9 & 20 series TIG torches
- Sizes shown refer to the ID of the cup (at gas outlet end)



Part No.	Description	REF	Unit
WC-53N58P	# 4 6.4mm (ref 53N58)		Pkt 2
WC-53N59P	# 5 7.9mm (ref 53N59)	5	Pkt 2
WC-53N60P	# 6 9.5mm (ref 53N60)	6	Pkt 2
WC-53N61P	# 7 11.1mm (ref 53N61)	7	Pkt 2
WC-53N61SP	# 8 12.7mm (53N61S)	8	Pkt 2

TIG CERAMIC 'ALUMINA' CUPS 9/20 SERIES

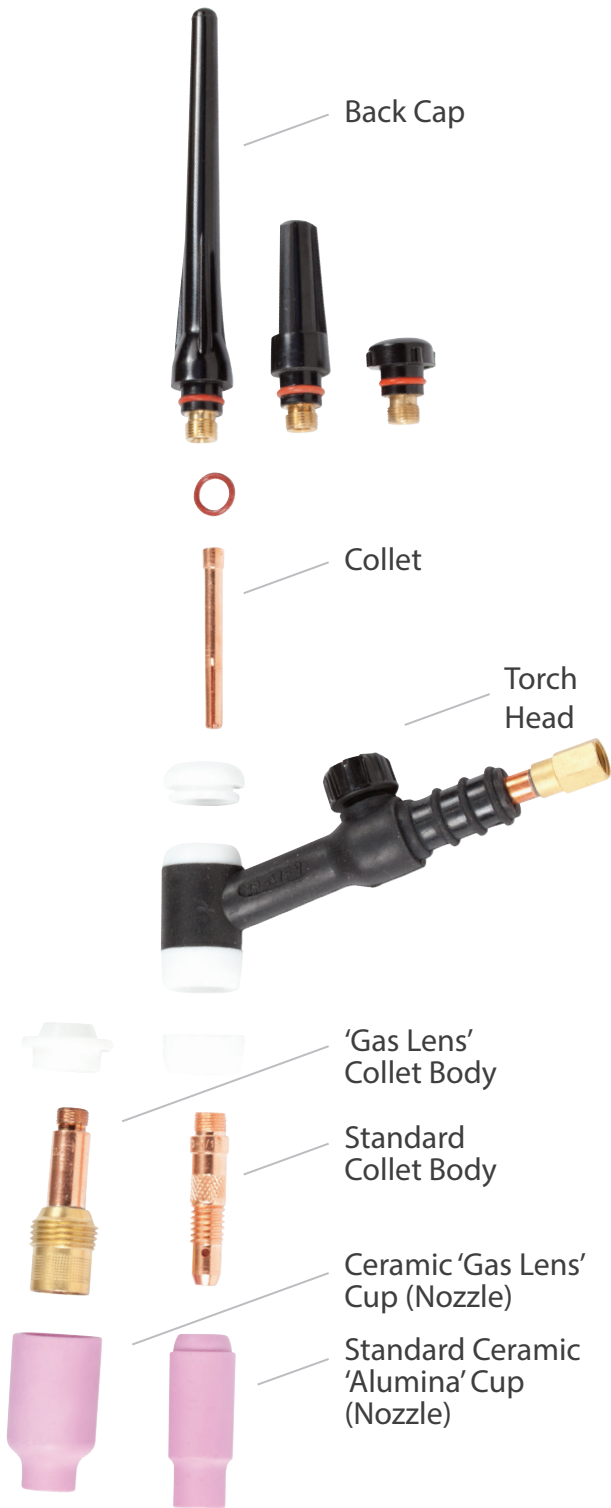
- Suit 9 & 20 series TIG torches
- Sizes shown refer to the ID of the cup (at gas outlet end)



Part No.	Description	REF	Unit
P3-13N08	# 4 6.4mm (ref 13N08)	4	Pkt 2
P3-13N09	# 5 7.9mm (ref 13N09)	5	Pkt 2
P3-13N10	# 6 9.5mm (ref 13N10)	6	Pkt 2
P3-13N11	# 7 11.1mm (ref 13N11)	7	Pkt 2
P3-13N12	# 8 12.7mm (ref 13N12)	8	Pkt 2

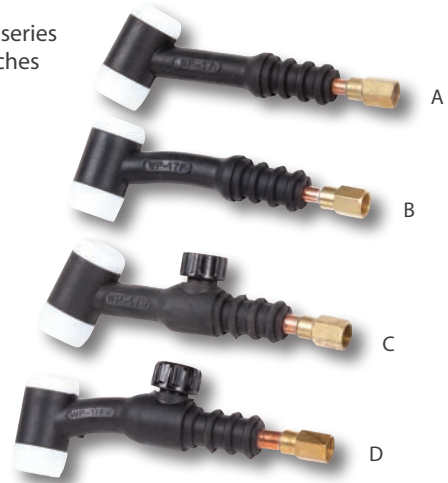


TIG PARTS DIAGRAM 17/26 SERIES



TIG TORCH BODIES 17 SERIES

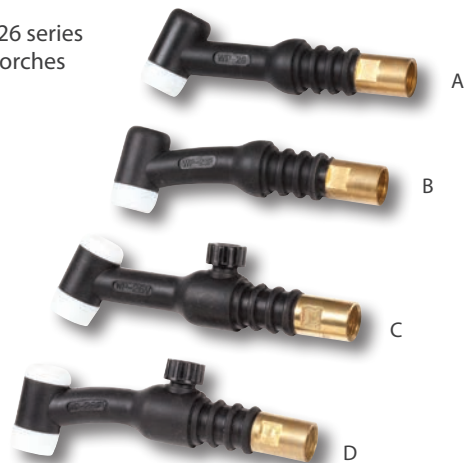
- Suit 17 series TIG torches



Part No.	Description	REF	Unit
P3-TB17	17 Standard (No Valve)	A	Pkt 1
P3-TB17F	17F Flexible (No Valve)	B	Pkt 1
P3-TB17V	17V Valved	C	Pkt 1
P3-TB17FV	17FV Flexible Valved	D	Pkt 1

TIG TORCH BODIES 26 SERIES

- Suit 26 series TIG torches



Part No.	Description	REF	Unit
P3-TB26	26 Standard (No Valve)	A	Pkt 1
P3-TB26F	26F Flexible (No Valve)	B	Pkt 1
P3-TB26V	26V Valved	C	Pkt 1
P3-TB26FV	26FV Flexible Valved	D	Pkt 1



TIG BACK CAPS 17/18/26 SERIES

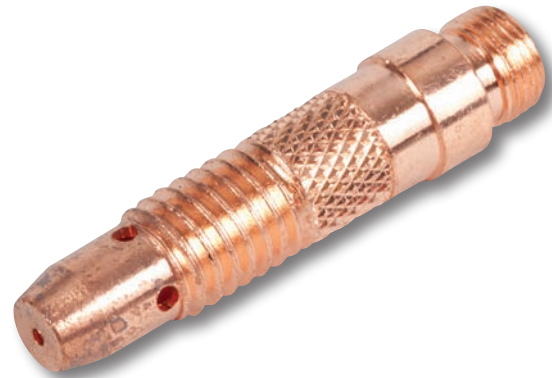
- Suit 17, 18 & 26 Series TIG torches



Part No.	Description	REF	Unit
WC-57Y02P	Long (ref 57Y02)	A	Pkt 2
WC-57Y05P	Medium (ref 57Y05)	B	Pkt 2
WC-57Y04P	Short (ref 57Y04)	C	Pkt 2

TIG COLLET BODIES 17/18/26 SERIES

- Suit 17, 18, & 26 series TIG torches



Part No.	Description	Unit
P3-10N31	1.6mm (ref 10N31)	Pkt 2
P3-10N32	2.4mm (ref 10N32)	Pkt 2
P3-10N28	3.2mm (ref 10N28)	Pkt 2

TIG COLLETS 17/18/26 SERIES

- Suit 17, 18 & 26 series TIG torches



Part No.	Description	Unit
P3-10N23	1.6mm (ref 10N23)	Pkt 2
P3-10N24	2.4mm (ref 10N24)	Pkt 2
P3-10N25	3.2mm (ref 10N25)	Pkt 2

TIG 'GAS LENS' COLLET BODIES 17/18/26 SERIES

- Suit 17, 18 & 26 series TIG torches
- Gas Lens style, for smooth gas flow & even gas shield



Part No.	Description	Unit
WC-45V25P	1.6mm (ref 45V25)	Pkt 2
WC-45V26P	2.4mm (ref 45V26)	Pkt 2
WC-45V27P	3.2mm (ref 45V27)	Pkt 2



TIG CERAMIC 'ALUMINA' CUPS 17/18/26 SERIES

- Suit 17, 18 & 26 series TIG torches
- Sizes shown refer to the ID of the cup (at gas outlet end)



Part No.	Description	REF	Unit
P3-10N50	# 4 6.4mm (ref 10N50)	4	Pkt 2
P3-10N49	# 5 7.9mm (ref 10N49)	5	Pkt 2
P3-10N48	# 6 9.5mm (ref 10N48)	6	Pkt 2
P3-10N47	# 7 11.1mm (ref 10N47)	7	Pkt 2
P3-10N46	# 8 12.7mm (ref 10N46)	8	Pkt 2
P3-10N45	# 10 15.8mm (ref 10N45)	10	Pkt 2

TIG CERAMIC 'GAS LENS' CUPS 17/18/26 SERIES

- Suits 17, 18 & 26 series TIG torches
- Sizes shown refer to the ID of the cup (at gas outlet end)



Part No.	Description	REF	Unit
WC-54N18P	# 4 6.4mm (ref 54N18)		Pkt 2
WC-54N17P	# 5 7.9mm (ref 54N17)	5	Pkt 2
WC-54N16P	# 6 9.5mm (ref 54N16)	6	Pkt 2
WC-54N15P	# 7 11.1mm (ref 54N15)	7	Pkt 2
WC-54N14P	# 8 12.7mm (ref 54N14)	8	Pkt 2
WC-53N88P	# 10 15.8mm (ref 53N88)	10	Pkt 2

TIG INSULATORS / GASKETS 17/18/26 SERIES

- Suitable for 17/18/26 series TIG torches



Part No.	Description	Unit
WC-187P	Gasket for Back Cap 17/18/26 (ref 187)	Pkt 2
WC-54N01P	Gasket for 'Gas Lens' Cups 17/18/26 (54N01)	Pkt 2



GAS EQUIPMENT



A quick look at...

Weldclass GAS REGULATORS Platinum



Argon

Simple & Durable Gauges
Easy-to-read colour coding
Impact resistant gauge face

Robust Body Construction
Machined from solid brass
Exceptional durability

Robust Knob Construction
Low-profile knob with heavy duty spindle to resist damage & shocks

Quality Without Shortcuts...
12 month Warranty
Manufacturing & Quality-Control by engineers with over 35 years experience
Individually QC tested
Date stamped for periodic testing in accordance with AS4839



Argon-Bobbin



CO2



Oxygen



Acetylene



LPG



OXY KITS PLATINUM SERIES OXY/ACETYLENE

- Heavy duty Platinum series oxygen/acetylene cutting, welding and brazing kits
- 12 month warranty on regulators, blowpipe handle and cutting attachment
- Bonus combination circle/roller guide
- Robust stainless steel tool box with plenty of space

KIT CONTAINS:

Oxygen Regulator, Acetylene regulator, Blowpipe handle, Cutting Attachment, Brazing Mixer, 3 Brazing Tips, 3 Cutting Tips, 10m Hose Set, Tip Cleaners, Flint Lighter, Combination Circle/Roller Guide, Shade 5 Oxy Specs, Multipurpose spanner. Model 4-OXACK/FRT also includes set of 4 Flash-back Arrestors



Part No.	Description	Unit
4-OXACK/FRT	PLATINUM Series with Flashback Arrestors	Kit
4-OXACK	PLATINUM Series	Kit

OXY KITS PLATINUM SERIES OXY/LPG

- Heavy duty Platinum series Oxygen/LPG cutting and brazing kits
- 12 month warranty on regulators, blowpipe handle and cutting attachment
- Bonus combination circle/roller guide
- Robust stainless steel tool box with plenty of space

KIT CONTAINS:

Blowpipe handle, cutting attachment, mixer, Oxygen regulator, LPG regulator, 3 brazing tips, 3 cutting tips, 10m hose set, tip cleaners, flint lighter, combination circle/roller guide, shade 5 oxy specs and multipurpose spanner. Model 4-OXLPK/FRT also includes set of 4 Flashback Arrestors



Part No.	Description	Unit
4-OXLPK/FRT	PLATINUM Series with Flashback Arrestors	Kit
4-OXLPK	PLATINUM Series	Kit



REGULATORS ARGON TWIN-GAUGE STYLE (MIG/TIG)

- Heavy Duty Platinum Series
- Solid brass body and bonnet
- 12 month warranty
- Spare parts available
- User friendly colour coded gauges
- For MIG or TIG use
- 0-28 L/min flow rate



Part No.	Description	Unit
4-AR1	PLATINUM Series 0-28L/min	Each

REGULATORS ARGON BOBBIN STYLE (MIG/TIG)

- Heavy Duty Platinum Series
- Solid brass body and bonnet
- 12 month warranty
- Spare parts available
- User friendly colour coded gauge
- For MIG or TIG use
- Available in 0-15 and 0-25 L/min flow rate



Part No.	Description	Unit
4-ABFR15	PLATINUM Series 0-15L/min	Each
4-ABFR25	PLATINUM Series 0-25L/min	Each

FLOWMETERS

- Fit to Bobbin style regulators
- Also used on pipeline systems



Part No.	Description	Unit
4-BF15	PLATINUM Series 0-15L/min (Flowmeter Only)	Each
4-BF25	PLATINUM Series 0-25L/min (Flowmeter Only)	Each



REGULATORS CO2

- Heavy Duty Platinum Series
- Solid brass body and bonnet
- 12 month warranty
- Spare parts available
- User friendly colour coded gauges
- For MIG or TIG use
- 0-28 L/min flow rate



Part No.	Description	Unit
4-CO2R1	PLATINUM Series 0-28L/min	Each

REGULATORS NITROGEN

- 12 month warranty
- Spare parts available
- 0-3400KPa (500psi) output



Part No.	Description	Unit
4-S200NTN	0-3440kpa / 0-500psi T50 Inlet	Each

GAS FLOW TESTER

- Quickly & Easily Diagnose Gas Flow Issues
- For MIG & TIG Torches - Measures gas flow at MIG or TIG nozzle
- Great for locating gas leaks or restrictions



Part No.	Description	Unit
P4-GFT	Argon or CO2	Each



REGULATORS OXYGEN

- Heavy Duty Platinum Series
- Solid brass body and bonnet
- 12 month warranty
- Spare parts available
- User friendly colour coded gauges
- 0-1000 Kpa output



Part No.	Description	Unit
4-OXR1	PLATINUM Series 0-1,000 Kpa	Each

REGULATORS ACETYLENE

- Heavy Duty Platinum Series
- Solid brass body and bonnet
- 12 month warranty
- Spare parts available
- Performance series
- User friendly colour coded gauges
- 0-150Kpa output



Part No.	Description	Unit
4-ACR1	PLATINUM Series 0-150 Kpa	Each

REGULATORS LPG/PROPANE

- Heavy Duty Platinum Series
- Solid brass body and bonnet
- 12 month warranty
- Spare parts available
- User friendly colour coded gauges
- 0-300KPa output
- For cutting, heating and brazing



Part No.	Description	Unit
4-LPR1	PLATINUM Series 0-300 Kpa	Each



FLASHBACK ARRESTORS

- Conform to AS4603-1999
- Individually flashback, flow & leak tested
- Certified to EN730
- Made in France
- Thermal cut off valve for protection against sustained flashback (on Regulator-end Models)

*Conforms to AS4603
Made in Europe*



Part No.	Description	Unit
P4-FBARF2	Regulator Mount Fuel Gas (Acetylene/LPG) - AS4603	Each
P4-FBARO2	Regulator Mount Oxygen - AS4603	Each
P4-FBATF	Torch Mount Fuel Gas (Acetylene/LPG) - AS4603	Each
P4-FBATO	Torch Mount Oxygen - AS4603	Each

QUICK COUPLINGS FOR OXY GEAR

- Allows equipment to be quickly and safely dismantled/assembled
- Fast change between hoses and different torches
- Made in France
- Complies with ISO7289 / EN561 Standards
- Automatically shuts off when disconnected, Patented locking mechanism prevents accidental disconnection
- Use for Oxy, Acetylene, LPG, MIG and TIG gas

Part No.	Description	Unit
P4-RQCF	Regulator Mount - Coupler - Fuel Gas (Acetylene/LPG)	Each
P4-RQCO	Regulator Mount - Coupler - Oxygen or Argon	Each
P4-TQCF	Torch Mount - Coupler - Fuel Gas (Acetylene/LPG)	Each
P4-TQCO	Torch Mount - Coupler - Oxygen or Argon	Each
P4-RQPF	Regulator Mount - Pin Only - Fuel Gas (Acetylene/LPG)	Each
P4-RQPO	Regulator Mount - Pin Only - Oxygen or Argon	Each
P4-TQPF	Torch Mount - Pin Only - Fuel Gas (Acetylene/LPG)	Each
P4-TQPO	Torch Mount - Pin Only - Oxygen or Argon	Each



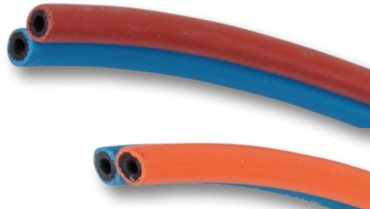
Regulator Mount

Torch Mount



HOSE TWIN

- Long life formula
- Ozone resistant and oil resistant



Part No.	Description	Unit
4-TWAC5	Oxy/Acetylene (Blue/Red) 5mm ID	Mtr
4-TWLP5	Oxy/LPG (Blue/Orange) 5mm ID	Mtr

HOSE SINGLE

- Long life formula
- Ozone resistant and oil resistant



Part No.	Description	Unit
4-SLP5	LPG/Propane (Orange) 5mm ID	Mtr
4-SOX5	Oxygen (Blue) 5mm ID	Mtr

HOSE SETS LPG SINGLE

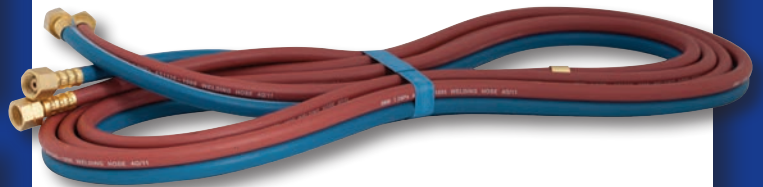
- Suitable for use with LPG burner/heating torches
- 5/8 UNF Connections



Part No.	Description	Unit
4-SLP10M	10 Mtr (5mm ID Orange) 5/8 Female LH Fittings	Each
4-SLP5M	5 Mtr (5mm ID Orange) 5/8 Female LH Fittings	Each

HOSE SETS OXY/ACETYLENE

- Long life formula
- Ozone resistant and oil resistant
- 5mm I.D.
- 5/8 UNF Australian standard hose connections



Part No.	Description	Unit
4-AC5M	05 Mtr (5mm ID Blue/Red)	Each
4-AC10M	10 Mtr (5mm ID Blue/Red)	Each
4-AC15M	15 Mtr (5mm ID Blue/Red)	Each
4-AC20M	20 Mtr (5mm ID Blue/Red)	Each

HOSE SETS OXY/LPG

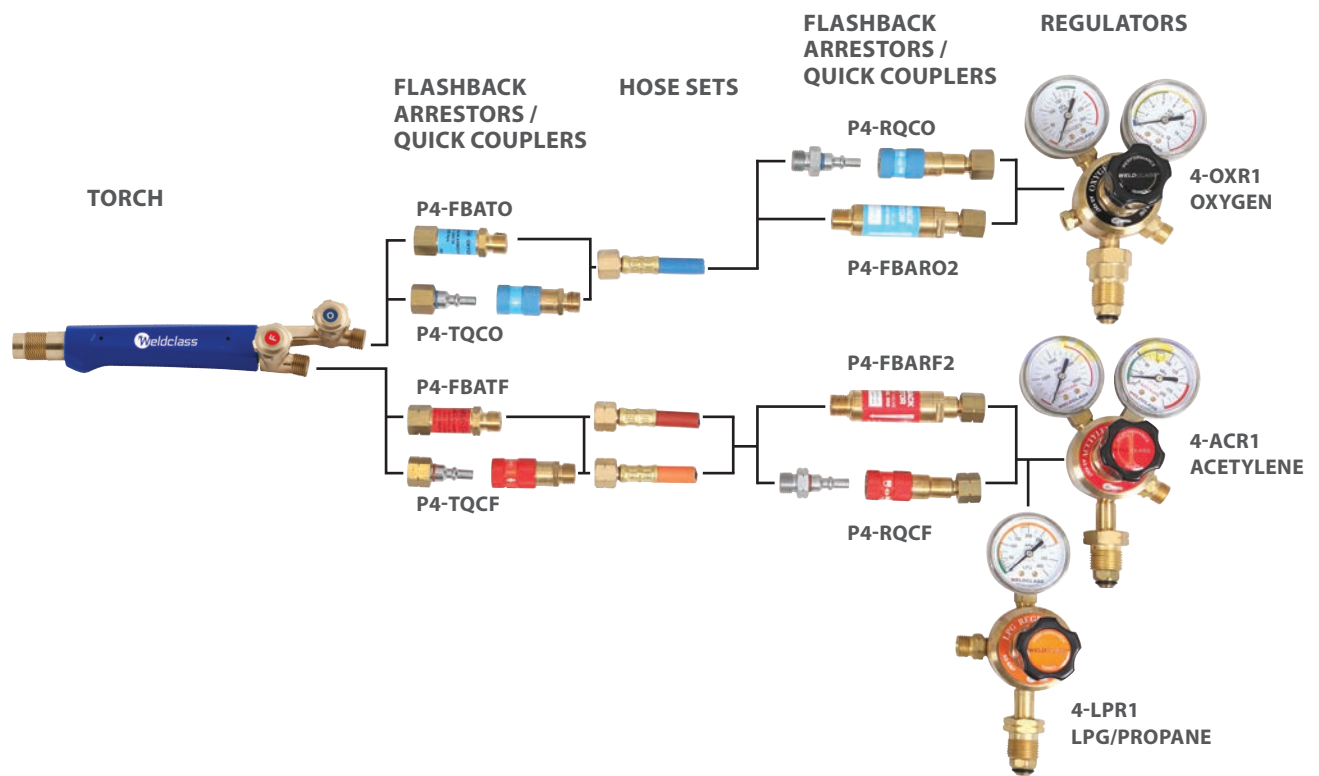
- Long life formula
- Ozone resistant and oil resistant
- 5mm I.D.
- 5/8 UNF Australian standard hose connections



Part No.	Description	Unit
4-LP5M	05 Mtr (5mm ID Blue/Orange)	Each
4-LP10M	10 Mtr (5mm ID Blue/Orange)	Each
4-LP15M	15 Mtr (5mm ID Blue/Orange)	Each

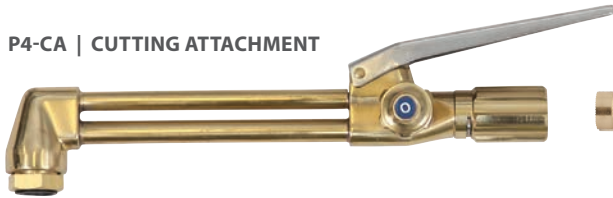


DIAGRAM
CYLINDER TO TORCH



**DIAGRAM - TORCH TO TIP
CUTTING & GOUGING**

P4-CA | CUTTING ATTACHMENT

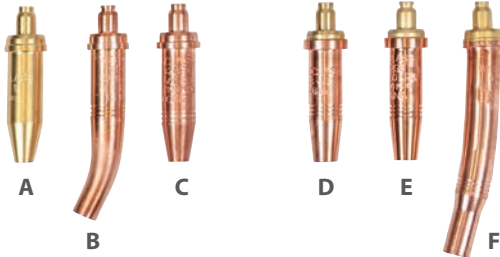


P4-BP | BLOW PIPE HANDLE



OXY/ACETYLENE

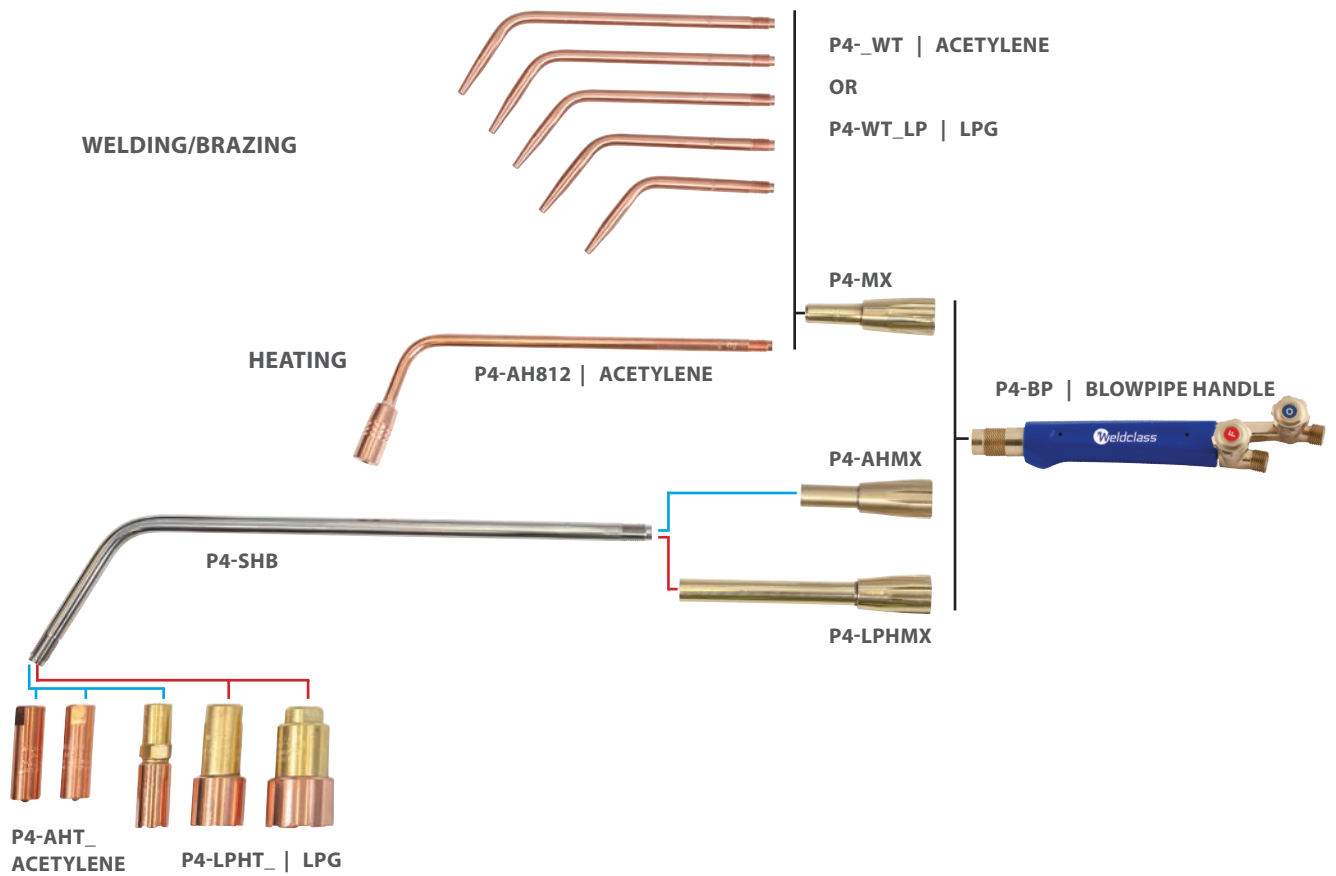
OXY / LPG



- A P4-T41_ | CUTTING
- B P4-41_GB | BENT GOUGING
- C P4-4132GS | STRAIGHT GOUGING
- D P4-T44_ | CUTTING
- E P4-4432GS | STRAIGHT GOUGING
- F P4-44_GB | BENT GOUGING



DIAGRAM - TORCH TO TIP HEATING & BRAZING



BLOWPIPE HANDLE PLATINUM SERIES

- Heavy duty Platinum Series
- Proven Quality, Robust Long-Life Design
- Dual-Stage Valves for quick and precise adjustment from fine work through to heavy cutting and heating
- Superior Valve Design with Tension System to Prevent Accidental Adjustment
- 12 Month Warranty
- Suitable for Oxygen/LPG and Oxygen/Acetylene gases
- Fits to Cutting Attachment (Part no P4-CA) or Brazing/Heating Mixers



Part No.	Description	Unit
P4-BP	PLATINUM Series	Each

CUTTING ATTACHMENT PLATINUM SERIES

- Heavy duty Platinum Series
- Proven Quality, Long-Life and Robust design
- Stainless-Steel Lever
- Superior Valve Design with Tension System to Prevent Accidental Adjustment
- 12 Month Warranty
- Suitable for Oxygen/LPG and Oxygen/Acetylene gases
- Fits to common blowpipe handle (part no. P4-BP)
- Takes standard Type 41 (Oxy/Acetylene) or Type 44 (Oxy/LPG) style cutting & gouging tips



Part No.	Description	Unit
P4-CA	PLATINUM Series	Each

MIXERS FOR BRAZING & HEATING

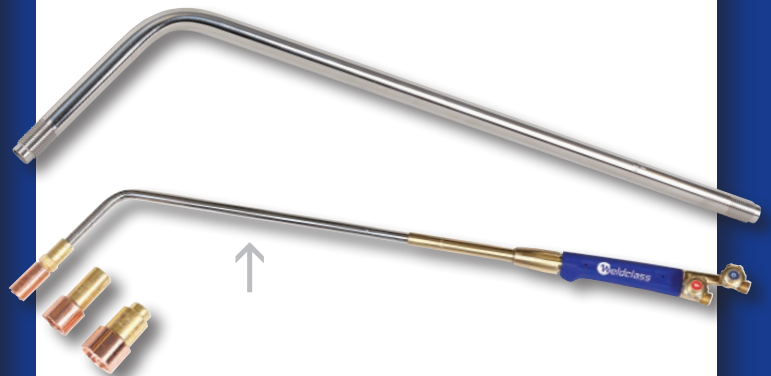
- Fits to standard Blowpipe Handle (part no P4-BP)
- P4-MX Standard Mixer: Use with brazing/welding tips
- P4-AHMX Heating Mixer: Use with Heating Barrel/Tube and Oxy/Acet or Oxy/LPG heating tips up to size 2
- P4-LPHMX Hi-Flow Heating Mixer: Use with Heating Barrel/Tube and Oxy/LPG heating tips from size 3 upwards



Part No.	Description	Unit
P4-AHMX	Heating - Oxy/Acet or Oxy/LPG (Takes Heating Tube/Barrel)	Each
P4-LPHMX	Heating - Oxy/LPG Hi-Flow (Takes Heating Tube/Barrel)	Each
P4-MX	Brazing - Oxy/Acet or Oxy/LPG (Takes T551/554 Brazing Tips)	Each

HEATING BARRELS/TUBES STAINLESS-STEEL

- Stainless-Steel for durability and strength
- Suitable for Oxygen/LPG and Oxygen/Acetylene gases
- Connect to Heating mixer - Use with P4-AHMX or P4-LPHMX mixers
- Takes Oxy/Acetylene or Oxy/LPG Heating Tips



Part No.	Description	Unit
P4-SHB	450mm Bent Stainless-Steel	Each



CUTTING TIPS T41 OXY/ACETYLENE

- Proven Consistent Quality, Long-Life Design
- Standard Shape - Fits Common Roller/ Circle Guides
- Fits to standard cutting attachment (P4-CA)
- Use with oxygen/acetylene



Part No.	Description	Unit
P4-T416	Size 6 (1-6mm)	Each
P4-T418	Size 8 (6-10mm)	Each
P4-T4112	Size 12 (10-20mm)	Each
P4-T4115	Size 15 (20-75mm)	Each
P4-T4120	Size 20 (75-125mm)	Each
P4-T4124	Size 24 (125-200mm)	Each
P4-T4132	Size 32 (200-275mm)	Each

CUTTING TIPS T44 OXY/LPG

- Proven Quality, Long-Life Design
- Standard Shape - Fits Common Roller/ Circle Guides
- Fits to standard cutting attachment (P4-CA)
- Use with Oxygen/LPG



Part No.	Description	Unit
P4-T446	Size 6 (3-6mm)	Each
P4-T448	Size 8 (6-12mm)	Each
P4-T4412	Size 12 (12-20mm)	Each
P4-T4415	Size 15 (20-75mm)	Each
P4-T4420	Size 20 (75-125mm)	Each
P4-T4424	Size 24 (125-200mm)	Each
P4-T4432	Size 32 (200-275mm)	Each



CUTTING TIPS T51 OXY/ACETYLENE '3-SEAT'

- 3 seat design suits most straight line and profile cutting machine torches and some one piece hand held cutting torches
- Use with oxygen/acetylene



Part No.	Description	Unit
P4-T510	Size 0 (5-10mm)	Each
P4-T5100	Size 00 (0-5mm)	Each
P4-T511	Size 1 (10-15mm)	Each
P4-T512	Size 2 (15-30mm)	Each
P4-T513	Size 3 (30-40mm)	Each
P4-T514	Size 4 (40-50mm)	Each
P4-T515	Size 5 (50-100mm)	Each
P4-T516	Size 6 (100-150mm)	Each
P4-T517	Size 7 (150-250mm)	Each
P4-T518	Size 8 (250-350mm)	Each

CUTTING TIPS T54 OXY/LPG '3-SEAT'

- 3 seat design suits most straight line and profile cutting machine torches and some one piece hand held cutting torches
- Use with oxygen/LPG



Part No.	Description	Unit
P4-T540	Size 0 (5-10mm)	Each
P4-T5400	Size 00 (0-5mm)	Each
P4-T541	Size 1 (10-15mm)	Each
P4-T542	Size 2 (15-30mm)	Each
P4-T543	Size 3 (30-40mm)	Each
P4-T544	Size 4 (40-50mm)	Each
P4-T545	Size 5 (50-100mm)	Each
P4-T546	Size 6 (100-150mm)	Each
P4-T547	Size 7 (150-250mm)	Each
P4-T548	Size 8 (250-350mm)	Each

GOUGING TIPS T41 OXY/ACETYLENE

- Proven Consistent Quality, Long-Life Design
- Fast Metal Removal for repair of cracks, defects and weld preparation
- Available in Bent or Straight
- Fits to cutting attachment P4-CA
- Use with Oxy/Acetylene



Part No.	Description	Unit
P4-4132GB	Size 32GB Bent	Each
P4-4132GS	Size 32GS Straight	Each
P4-4148GB	Size 48GB Bent	Each

GOUGING TIPS T44 OXY/LPG

- Proven Consistent Quality, Long-Life Design
- Fast Metal Removal for repair of cracks, defects and weld preparation
- Available in Bent or Straight
- Fits to cutting attachment P4-CA
- Use with Oxy/LPG



Part No.	Description	Unit
P4-4432GB	Size 32GB Bent	Each
P4-4432GS	Size 32GS Straight	Each
P4-4448GB	Size 48GB Bent	Each



BRAZING TIPS OXY/ACETYLENE

- Quality swaged copper brazing/welding tips
- For use with oxygen/acetylene
- Suitable for brazing and fusion welding



Part No.	Description	Unit
P4-08WT	Size 8 (0.0-2.0mm)	Each
P4-10WT	Size 10 (2.0-2.6mm)	Each
P4-12WT	Size 12 (3.2-4.0mm)	Each
P4-15WT	Size 15 (5.0-6.5mm)	Each
P4-20WT	Size 20 (8.0-10.0mm)	Each

BRAZING OXY/LPG

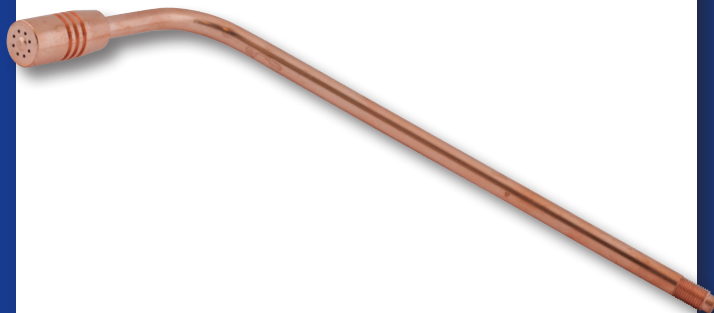
- Quality swaged copper brazing tips
- For use with oxygen/LPG
- Suitable for brazing



Part No.	Description	Unit
P4-08WTL	Size 8 (0.0-2.0mm)	Each
P4-10WTL	Size 10 (2.0-2.6mm)	Each
P4-12WTL	Size 12 (3.2-4.0mm)	Each
P4-15WTL	Size 15 (5.0-6.5mm)	Each
P4-20WTL	Size 20 (8.0-10.0mm)	Each

HEATING TIP OXY/ACETYLENE W/TUBE

- Quality swaged copper heating tip
- For use with oxygen/acetylene
- Fits to standard brazing mixer (P4-MX)
- For light to medium heating applications



Part No.	Description	Unit
P4-AH812	8x12 (Connects to P4-MX Mixer)	Each

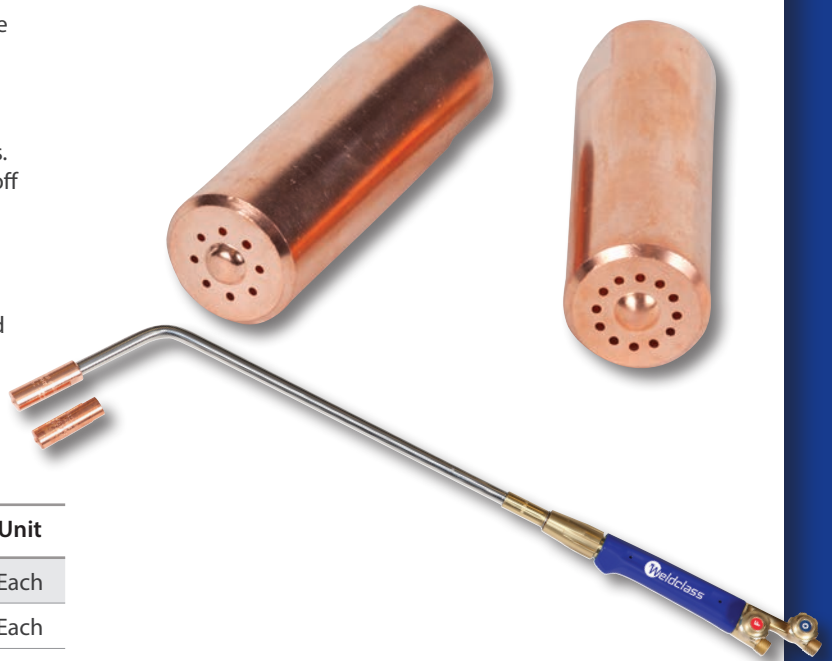


HEATING TIPS OXY/ACETYLENE

- Precision Machined to help Prevent flashback & back-fire
- Use with oxygen/acetylene
- Connects to P4-SHB Tube/Barrel

OPERATOR INFO:

- Heating with Oxy/Acetylene has limitations and hazards. Care must be taken to ensure that the maximum draw-off consumption rate of acetylene is not exceeded (consult your gas supplier for details). For this reason, Acetylene tips are available only up to size 2.
- Where possible, Weldclass recommends that Oxy/LPG be used in preference to Oxy/Acetylene. LPG is safer and less prone to flashback or backfire, and larger tip sizes are available for heavy heating. LPG is also often only a fraction of the cost of Acetylene.



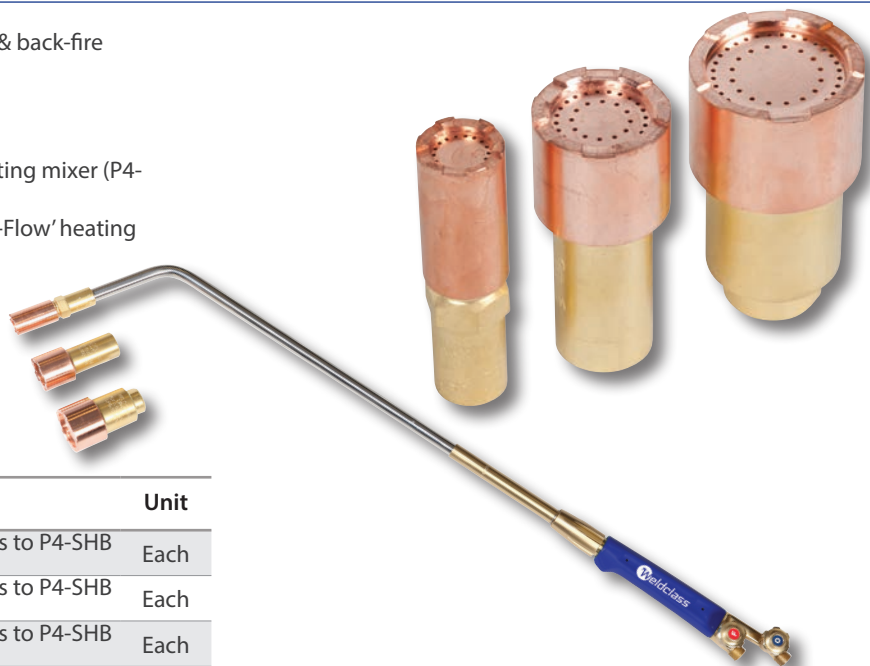
Part No.	Description	Unit
P4-AHT1	Size 1 (8 x 12) - Connects to P4-SHB Tube/Barrel	Each
P4-AHT2	Size 2 (12 x 12) - Connects to P4-SHB Tube/Barrel	Each

HEATING TIPS OXY/LPG

- Precision Machined to Prevent flashback & back-fire
- For use with Oxy/LPG
- Connects to P4-SHB Tube/Barrel

OPERATOR INFO:

- Tip size 1 can be used with 'standard' heating mixer (P4-AHMX).
- Tip sizes 2 & above must be used with 'Hi-Flow' heating mixer (P4-LPHMX)



Part No.	Description	Unit
P4-LPHT1	Size 1 (18 x 12) - Connects to P4-SHB Tube/Barrel	Each
P4-LPHT2	Size 2 (36 x 12) - Connects to P4-SHB Tube/Barrel	Each
P4-LPHT3	Size 3 (48 x 12) - Connects to P4-SHB Tube/Barrel	Each



LPG BURNER/HEATING TORCHES & KITS

- Air/LPG operation requires LPG gas only (no Oxygen required)
- More Portable than Oxy/Fuel Equipment & Very Economical to Run
- Robust Construction for Industrial Applications

APPLICATION INFO:

- For Light to Medium Heating Applications that do not require the Ultra-High Temperatures of an Oxy/Fuel Flame
- Preheating before welding, Drying, Thawing, Heating Bitumen/Asphalt, Curing Concrete, Vegetation Burn-Off, Shrink-Wrapping, etc

OPERATION INFO:

- Use with Standard LPG (BBQ Cylinder) and LPG regulator
- Hose/Inlet Connection is Standard 5/8" UNF LH Thread - as used on all standard Oxy/Gas Equipment

Part No.	Description	Unit
P4-LPBK1	Torch - 500mm w/ 3 Tips (25, 38, 51mm)	Each
WC-02992K	Torch Kit - 500mm w/ Regulator & 5m Hose	Kit
P4-LPBK2	Torch 800mm w/ Pilot Lever, 60mm Tip	Each
WC-02993K	Torch Kit - 800mm w/ Regulator & 10m Hose	Kit
P4-LPBT1	Tip #1 (25mm)	Each
P4-LPBT2	Tip #2 (38mm)	Each
P4-LPBT3	Tip #3 (51mm)	Each
P4-LPBT4	Tip #4 (60mm)	Each



P4-LPBK1
500mm Torch Only

INDICATIVE PRICE
P4-LPBK1
\$180⁰⁰ Excl GST*

For your nearest Distributor
Phone 1300 784 200

*Prices are indicative only and may vary depending on volumes, freight cost, models/options & other factors

WC-02992K
800mm Torch Kit
W/ Regulator & 5m Hose

INDICATIVE PRICE
WC-02992K
\$329⁰⁰ Excl GST*

For your nearest Distributor
Phone 1300 784 200

*Prices are indicative only and may vary depending on volumes, freight cost, models/options & other factors

P4-LPBK2
800mm Torch Only

INDICATIVE PRICE
P4-LPBK2
\$190⁰⁰ Excl GST*

For your nearest Distributor
Phone 1300 784 200

*Prices are indicative only and may vary depending on volumes, freight cost, models/options & other factors

WC-02993K
800mm Torch Kit
W/ Regulator & 10m Hose

INDICATIVE PRICE
WC-02993K
\$359⁰⁰ Excl GST*

For your nearest Distributor
Phone 1300 784 200

*Prices are indicative only and may vary depending on volumes, freight cost, models/options & other factors



CUTTING TORCHES

PLATINUM 50/70 SERIES

- 12 month warranty
- Spare parts available
- Uses 3-Seat / Type 51/54 Cutting Tips
- Cutting lever can be locked on
- Made in Europe - Very Robust, Long life design



Part No.	Description	Unit
WC-05198	600mm - 180DG Straight Head	Each
WC-05197	600mm - 90DG Right-Angle Head	Each
4-CTP5/1000S	1,000mm - 180DG Straight Head	Each
4-CTP5/1000R	1,000mm - 90DG Right-Angle Head	Each

FLINT LIGHTERS

- Quality flint lighters and flint renewals



Part No.	Description	Unit
P4-SFL	Single Flint Lighter	Each
P4-TFL	Triple Flint Lighter	Each
P4-SFR	Single Flint Replacements	Pkt 10
P4-TFR	Triple Flint Replacements	Pkt 5

TIP CLEANERS

- Abrasive wires remove carbon build up and loose slag from nozzles and tips
- Extra long tip cleaners are suitable for 3 seat cutting tips

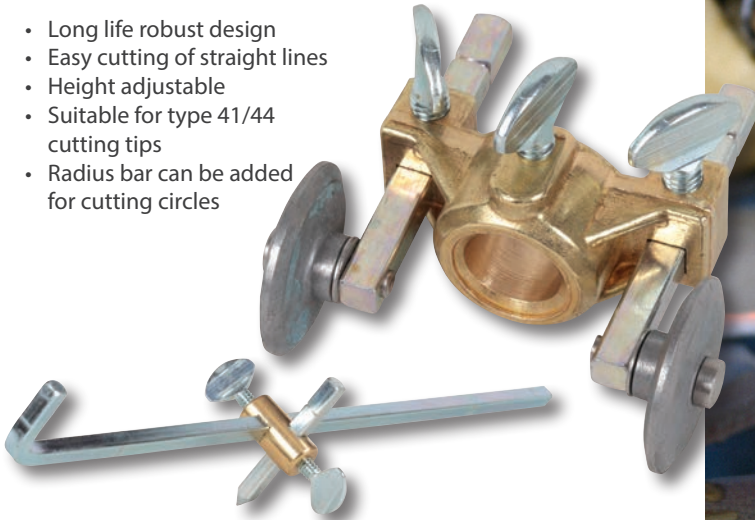


Part No.	Description	Unit
P4-TC	Standard 100mm	Each
P4-TCL	Long 125mm	Each



ROLLER GUIDE

- Long life robust design
- Easy cutting of straight lines
- Height adjustable
- Suitable for type 41/44 cutting tips
- Radius bar can be added for cutting circles



Part No.	Description	Unit
P4-TJ1602	Roller Guide Set	Set
P4-TJ6051	Radius Bar - fits TJ4602 Roller Guide to allow circle cutting	Kit

CIRCLE GUIDE

- Long life robust design
- 360 degree cutting from one position
- Height adjustable
- Cuts circles 25-730mm diameter
- Suitable for type 41/44 cutting tips
- Magnetic pivot can be used for a secure pivot point

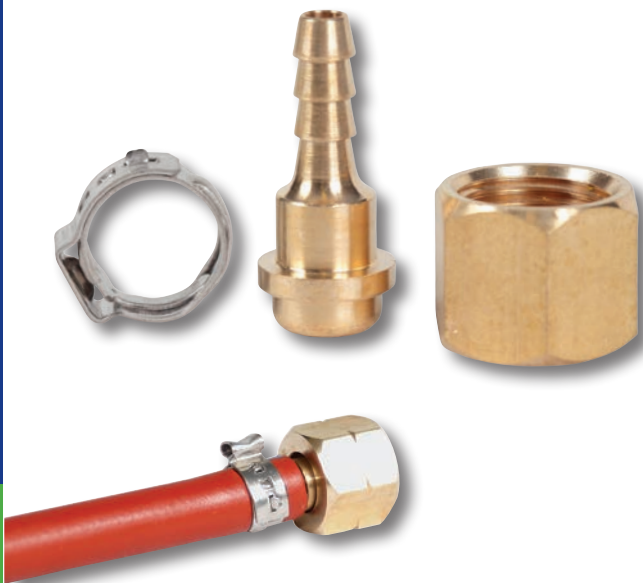


Part No.	Description	Unit
P4-TJ1083	Circle Guide Set	Set
P4-TJ6086	Magnetic Pivot - Suit Circle Guide TJ1083	Each



HOSE CONNECTOR KITS CRIMP-ON

- Kit includes hose clamp, brass nut and tail
- Easy to use and quick to install (use pliers)
- Firm clamp designs prevent leaks



Part No.	Description	Unit
P4-LHHCK	Suit 5mm I.D. Hose - LH Acet/LPG	Kit
P4-RHHCK	Suit 5mm I.D. Hose - RH Oxy/Argon	Kit
P4-LHHCK10	Suit 10mm I.D. Hose - LH Acet/LPG	Kit
P4-RHHCK10	Suit 10mm I.D. Hose - RH Oxy	Kit

HOSE JOINERS SCREW-ON

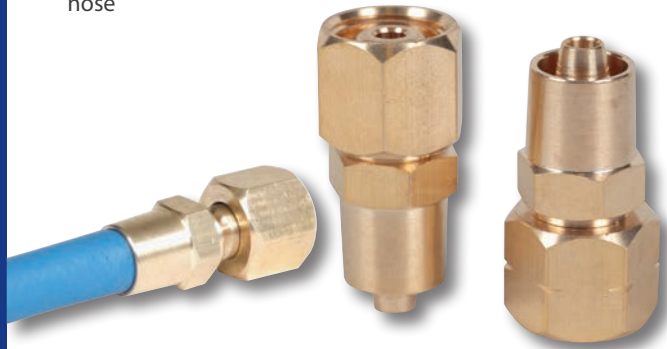
- Brass screw type hose joiner suitable for joining 5mm I.D. hose



Part No.	Description	Unit
4-LP265	Suit 5mm I.D. Hose	Each
P4-LP265	Suit 5mm I.D. Hose - Carded Single Pack	Pkt 1

HOSE CONNECTORS SCREW-ON

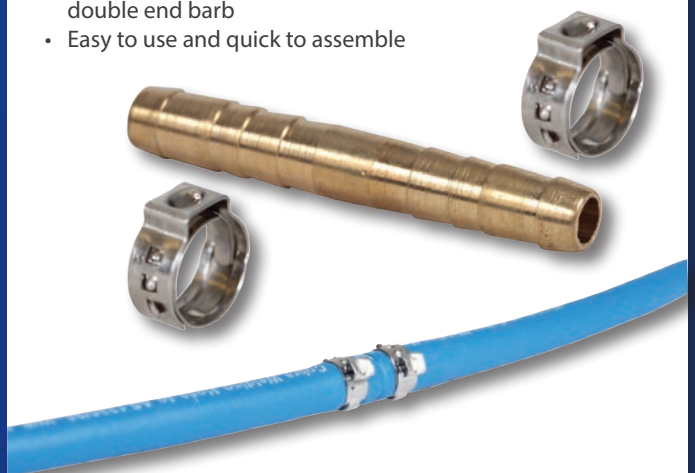
- Brass screw type hose connector suitable for 5mm I.D. hose



Part No.	Description	Unit
4-LP112	Suit 5mm I.D. Hose - RH Oxy/Argon	Each
P4-LP112	Suit 5mm I.D. Hose - RH Oxy/Argon - Carded Single Pack	Pkt 1
4-LP240	Suit 5mm I.D. Hose - LH Acet/LPG	Each
P4-LP240	Suit 5mm I.D. Hose - LH Acet/LPG - Carded Single Pack	Pkt 1

HOSE JOINER KITS CRIMP-ON

- Kit includes 2x stainless steel hose clamps and a brass double end barb
- Easy to use and quick to assemble



Part No.	Description	Unit
P4-DEBK	Suit 5mm I.D. Hose	Kit
P4-DEBK10	Suit 10mm I.D. Hose	Kit



HOSE CLAMPS (1-EAR)

- Easy and quick to install (use pliers)
- One ear design
- Stainless steel



Part No.	Description	Unit
P4-HFC095/10	09.5mm ID (Before Crimping) Suit TIG Hose	Pkt 10
P4-HFC133/10	13.3mm ID (Before Crimping) Suit 5mm ID Oxy/Argon Hose	Pkt 10
P4-HFC185/10	18.5mm ID (Before Crimping) Suit 10mm ID Oxy Hose	Pkt 10

HOSE COUPLERS

- For joining and connecting hose and hose sets



Part No.	Description	Unit
4-WB34	RH Oxy/Argon	Each
P4-WB34	RH Oxy/Argon - Carded	Single Pack
4-WB35	LH Acet/LPG	Each
P4-WB35	LH Acet/LPG - Carded	Single Pack

Y-PIECES

- For splitting gas supply from one line into two



Part No.	Description	Unit	Inner Qty	Outer Qty
P4-R121	RH Oxy/Argon	Pkt 1	1	10
P4-R215	LH Acet/LPG	Pkt 1	1	10

Y-PIECE WITH VALVES

- Valves allow each outlet to be independently opened or closed
- Saves time - no need to readjust regulator to open or close gas flow



Part No.	Description	Unit
P4-HFYVRH	RH Oxy/Argon	Pkt 1
P4-HFYVLH	LH Acet/LPG	Pkt 1



MACHINES



A quick look at...

Weldclass TX-180 PLATE CUTTER

**Use with Oxy/Acetylene
or Oxy/LPG**

Supplied with both
Acetylene & LPG tips

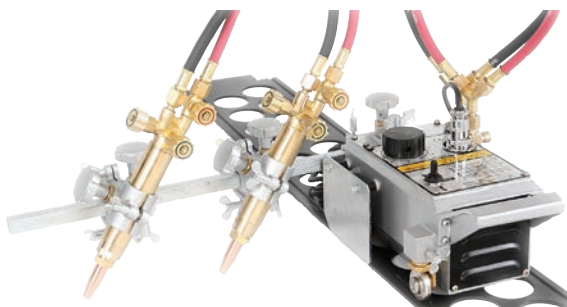
Tried, Tested, Proven
Simple, robust & reliable



**Straight or
Bevel Cutting**

Torch Configuration
Single or Twin Torch

Common Track Design
Interchangeable with other
machines



*Call 1300 784 200 for your
nearest distributor*



PLATE CUTTER TX-180

- Light weight and portable
- Robust design
- Use with Oxy/Acetylene or Oxy/LPG
- Straight or Bevel cutting of steel plate
- Uses common track design - track is interchangeable with other machines
- Horizontal and vertical torch adjustment
- Heat deflector
- Adjustable speed
- Forward and reverse



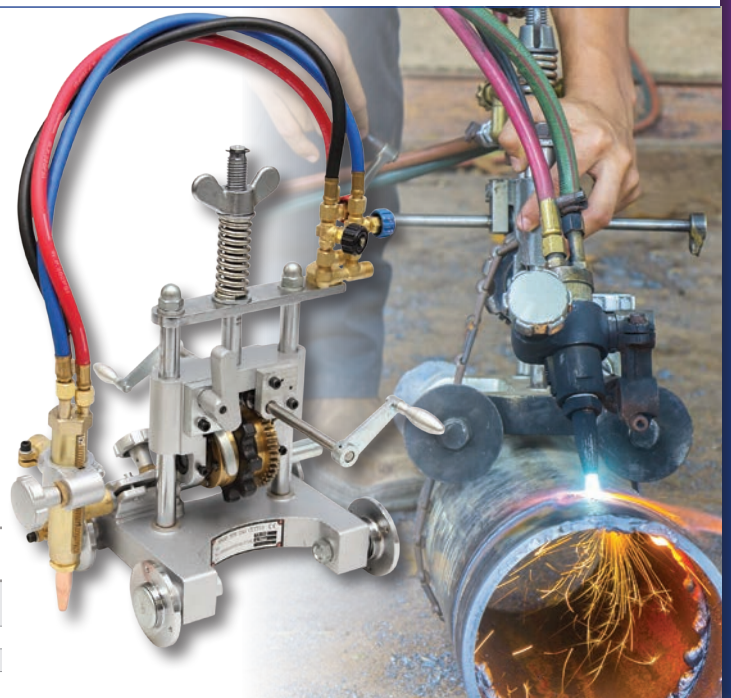
INDICATIVE PRICE
\$990⁰⁰ Excl GST*
For your nearest Distributor
Phone 1300 784 200
*Prices are indicative only and may vary depending on volumes, freight cost, models/options & other factors

Part No.	Description	Unit
5-TX180/1K	TX-180 Plate Cutter Package- with Single Torch & 1.8m Track	Kit
5-TX180TTK	TX-180 2 Torch Upgrade Kit (Converts 1-Torch Machine to 2-Torch)	Kit
5-TX180CCA	TX-180 Circle Cutting Attachment	Each
5-SX300T	Track 1.8m suits SX-300 & TX-180 & Various Other Models	Each

PIPE CUTTER TX-21Q

- Light weight and portable
- Robust design
- Ideal for cutting steel pipes 100mm or larger
- Use with Oxy/ Acetylene or Oxy/ LPG
- Horizontal and vertical torch adjustment
- Straight or bevel cutting
- Supplied with additional wheel flanges which bolt onto existing front wheels to increase chassis clearance for cutting smaller pipes
- Valves located away from the torch for easy operation

INDICATIVE PRICE
\$1,090⁰⁰ Excl GST*
For your nearest Distributor
Phone 1300 784 200
*Prices are indicative only and may vary depending on volumes, freight cost, models/options & other factors



Part No.	Description	Unit
5-TX21Q	TX-21Q Pipe Cutter w/Quick-Clutch & 2.4m Chain	Each
5-SX20C	Chain H/Duty Pressed-Metal 2.4m	Each
5-TX21CHAIN	Chain Std Cast Metal 2.4m	Each



ACCESSORIES, TOOLS, MARKERS



A quick look at...



'EC500H' EARTH CLAMP

Very Firm Cable Connection
Withstands high cable strain

Saves time, solves problems!

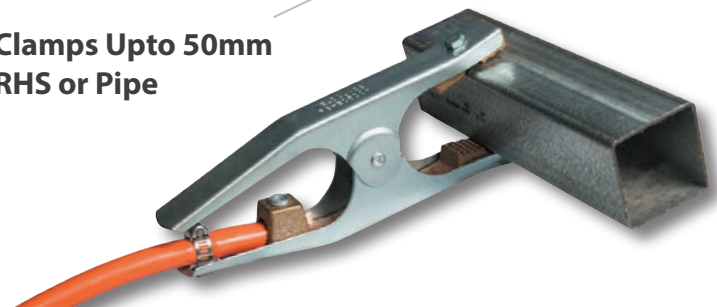
**One-piece Solid Brass
Cable Terminal & Jaw**
Very direct current flow
from cable to job to ensure
reliable earth connection &
minimal amperage loss



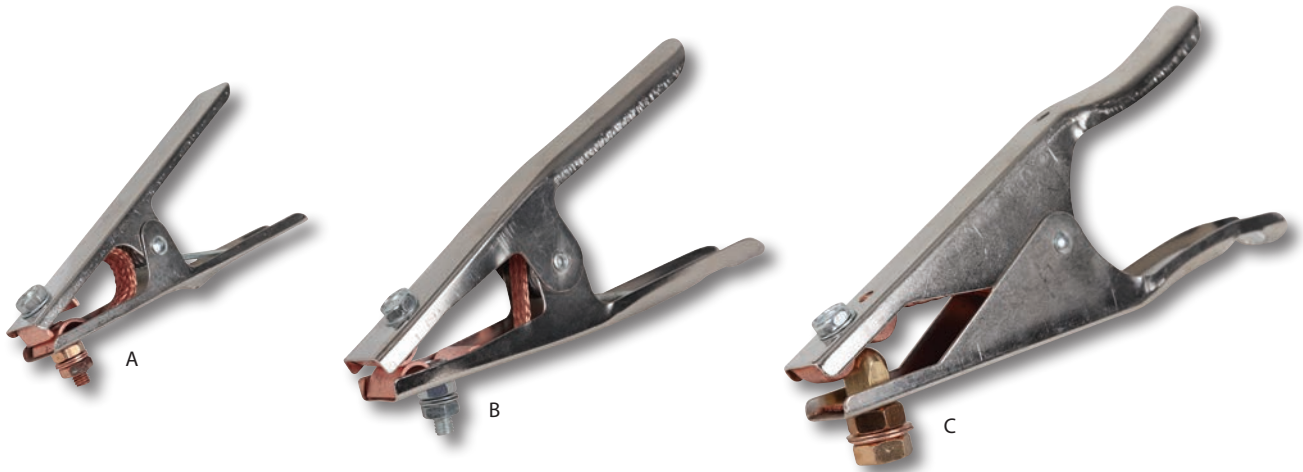
Very Fast & Easy to Fit
No cable lug required!
Cable Fits Directly to
Clamp using a Hex-Wrench
(supplied with the clamp)

**Clamps Upto 50mm
RHS or Pipe**

check out...



EARTH CLAMPS STANDARD



- Copper braided shunt for improved conductivity
- Suitable for MIG/STICK/TIG Welders

Part No.	Description	REF	Unit
P6-EC200	200 Amp	A	Each
P6-EC300	300 Amp	B	Each
P6-EC500	500 Amp	C	Each

EARTH CLAMPS PLATINUM EC500H

- Fast & Easy to Fit - No Cable Lug Required
- Robust and Durable
- One-Piece Cable Terminal and Jaw: Very direct current flow from the cable to the job
- For all types of Welders up to 500 Amps



Part No.	Description	Unit
P6-EC500H	500 Amp H/Duty (No Lug Required)	Each

EARTH CLAMPS PLATINUM EC600H

- Robust and Durable
- For all types of Welders up to 600 Amps



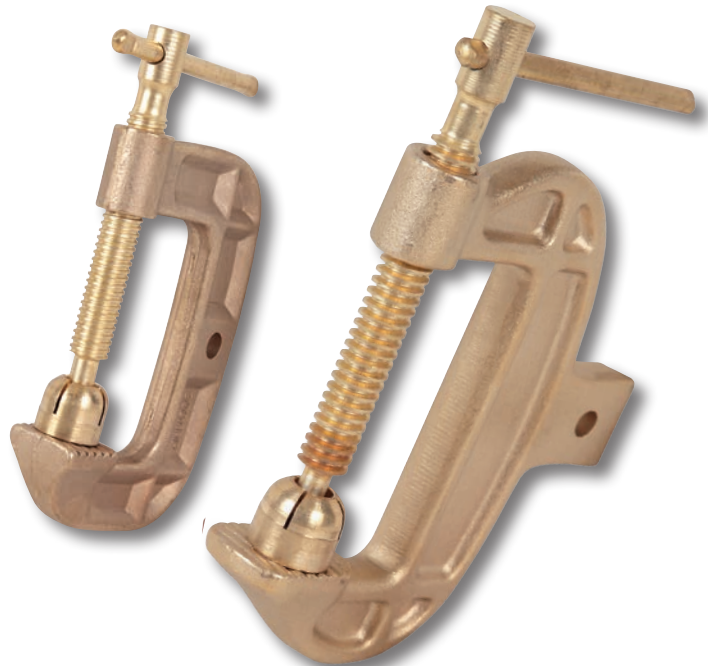
Part No.	Description	Unit
6-EC600H	600 Amp H/Duty	Each



EARTH CLAMPS PLATINUM BRASS G-STYLE

- Solid Brass Construction = Very Reliable Earth Connection & Long Service Life
- Withstands High Heat = For High Duty-Cycle Operations
- Will Not Rust = Suitable for All Environments, including Field Work
- Resists Spatter Build-Up
- Suitable for MIG/STICK/TIG Welders

*Solid brass, doesn't rust,
resists spatter build-up!*



Part No.	Description	Unit
P6-GC300	300 Amp (Max Opening 48mm)	Each
P6-GC500	500 Amp (Max Opening 65mm)	Each

EARTH CLAMPS MAGNETIC

- 800 amp rating
- Withstands high heat / high duty-cycle operations
- Ideal for use on large items, sheetmetal, etc



Part No.	Description	Unit
6-MEC	800 Amp	Each

BOOSTER CLAMPS

- 400 Amp rating
- Heavy duty copper jaw
- Rubber outer cover on jaws and hand grip
- Ideal for use with welding cable for booster lead sets



Part No.	Description	Unit
P6-BCB	400 Amp Black	Each
P6-BCR	400 Amp Red	Each



ELECTRODE HOLDERS PROMAX TWIST-LOCK

- Industrial quality
- Twist lock style

popular style



Part No.	Description	Unit
P6-TW400	400 Amp	Each
P6-TW600	600 Amp	Each



ELECTRODE HOLDERS PROMAX TONG STYLE

- Tong/Alligator style
- Industrial quality
- Suitable for lead sets for stick welders



Part No.	Description	Unit
P6-TG300	300 Amp	Each
P6-TG500	500 Amp	Each



CABLE CONNECTORS DINSE 10-25 STYLE

- Common Dinse style Twist-Lock Connector
- Suit Smaller MIG, Stick/MMA & TIG Welders up to approx 150-200 Amps
- Maximum cable size 35mm sq
- 9mm diameter Pin



Part No.	Description	Unit
P6-1025FP	Panel-Mount Socket Female	Each
P6-1025FC	Connector Female	Each
P6-1025MC	Connector Male (9mm Pin)	Each

CABLE CONNECTORS DINSE 35-50 STYLE

- Common Dinse style Twist-Lock Connector
- Suit Most MIG, Stick/MMA & TIG Welders from approx 150-200 Amps or more
- Maximum cable size 70mm sq
- 13mm diameter Pin



Part No.	Description	Unit
P6-3550FP	Panel-Mount Socket Female	Each
P6-3550FC	Connector Female	Each
P6-3550MC	Connector Male (13mm Pin)	Each

CABLE CONNECTORS ADAPTOR

- Converts From 10-25 Male To 35-50 Female
- For Fitting Cables with the larger 35-50 male connector to a machine (or another cable) with the small 10-25 female connector



Part No.	Description	Unit
P6-MFA	Male 10-25 to Female 35-50	Each

CABLE LUGS H/DUTY RE-USABLE

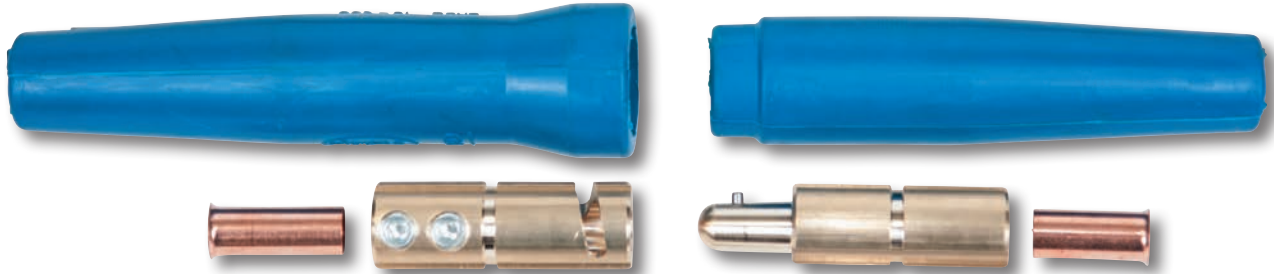
- Reusable lug with grub screw fitting
- Very easy to fit - no crimping or soldering
- Solid brass for long life and reliable connection
- Suitable for lead sets for MIG/STICK & TIG welders



Part No.	Description	Unit
P6-FL300	300 Amp (Suits Cable up to 50mm ²)	Each
P6-FL500	500 Amp (Suits Cable up to 70mm ²)	Each



CABLE JOINERS 500 AMP



- Quick reliable connection
- Commonly used on large engine-drive welders
- Compatible with other common brands
- Standard suits cable size up to 70mm²
- 95mm suits cable size 50-95mm²



Part No.	Description	Unit
WC-01499	Standard Male/female Set (Blue)	Each
WC-01493	Standard Female Only (Blue)	Each
WC-01495	Standard Male Only (Blue)	Each
WC-01867	95mm Male/female Set (Black)	Each

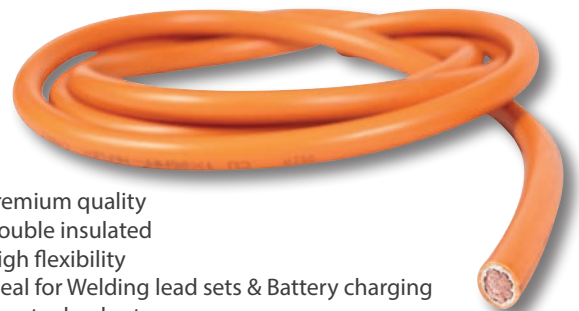
CABLE LUGS CRIMP STYLE

- Quality crimp style cable lugs
- Suitable for MIG/STICK/TIG Welders
- Crimp or solder onto welding cable



Part No.	Description	Unit
6-CL1610	Suit Cable 16mm ² - Hole 10mm	Each
6-CL1612	Suit Cable 16mm ² - Hole 12mm	Each
6-CL2510	Suit Cable 25mm ² - Hole 10mm	Each
6-CL2512	Suit Cable 25mm ² - Hole 12mm	Each
6-CL3510	Suit Cable 35mm ² - Hole 10mm	Each
6-CL3512	Suit Cable 35mm ² - Hole 12mm	Each
6-CL5010	Suit Cable 50mm ² - Hole 10mm	Each
6-CL5012	Suit Cable 50mm ² - Hole 12mm	Each
6-CL7010	Suit Cable 70mm ² - Hole 10mm	Each
6-CL7012	Suit Cable 70mm ² - Hole 12mm	Each
6-CL9510	Suit Cable 95mm ² - Hole 10mm	Each
6-CL9512	Suit Cable 95mm ² - Hole 12mm	Each

WELDING CABLE



- Premium quality
- Double insulated
- High flexibility
- Ideal for Welding lead sets & Battery charging booster lead sets

Part No.	Description	Unit
6-WC16	16mm ² (170 Amp@30%)	Mtr
6-WC16/100	16mm ² (170 Amp@30%)	Roll 100m
6-WC25	25mm ² (240 Amp@30%)	Mtr
6-WC25/100	25mm ² (240 Amp@30%)	Roll 100m
6-WC35	35mm ² (310 Amp@30%)	Mtr
6-WC35/100	35mm ² (310 Amp@30%)	Roll 100m
6-WC50	50mm ² (410 Amp@30%)	Mtr
6-WC50/100	50mm ² (410 Amp@30%)	Roll 100m
6-WC70	70mm ² (520 Amps@30%)	Mtr
6-WC70/100	70mm ² (520 Amps@30%)	Roll 100m
6-WC95	95mm ² (680 Amps@30%)	Mtr



ENGINEERS CHALK

- Resists Breakage & Powdering - No Wasting Time with Chalk that doesn't perform
- Consistently Top Quality - Expect the Same quality Every Time
- Cost Effective Non-Permenant Marking
- For marking steel in general engineering work
- Marks Steel, All Metals, Concrete, Masonary, etc
- Easy to use - Easy to remove

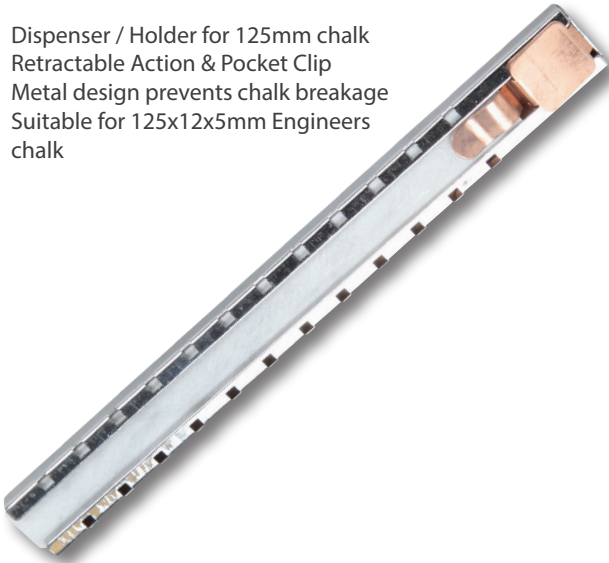
seriously snap-resistant!



Part No.	Description	Unit
6-EC7510	75 x 10 x 10mm Square -50 pcs/box	Box
6-EC755	75 x 10 x 5mm Split -100 pcs/box	Box
6-EC125	125 x 12 x 5mm Split -144 pcs/box (suit dispenser)	Box

CHALK DISPENSER

- Dispenser / Holder for 125mm chalk
- Retractable Action & Pocket Clip
- Metal design prevents chalk breakage
- Suitable for 125x12x5mm Engineers chalk



Part No.	Description	Unit
P6-ECD	Suits 6-EC125 Chalk	Each



WELDERS PENCILS SILVER-STREAK

- Superior to Chalk: Won't Rub or Burn Off
- Designed to Mark in All Conditions, Even Oily, Rusty or Wet Surfaces
- Highly Visible Marks Remain Visible During Cutting or Welding
- Durable marks will not scratch or abrade metal surfaces
- Perfect for layout marking prior to cutting / welding / fitting
- Marks: Mild steel and most metals



Part No.	Description	Unit
P6-WPS/3	Pkt 3 (Carded)	Pkt 3
6-WPS/12	Box 12	Box 12



WELDERS PENCILS RED-RITER

- Highly Visible on Galvanized Steel, Stainless-Steel and Aluminium, where other markers have poor visibility
- Superior to Chalk: Won't Rub or Burn Off
- Highly Visible Marks Remain Visible During Cutting or Welding
- Low-Chlorides / Low-Corrosion Formula - for peace of mind when using on Stainless Steel & other sensitive applications
- Perfect for layout marking prior to cutting / welding / fitting
- Marks: Mild steel and most metals



Part No.	Description	Unit
6-WPR/12	Box 12	Box 12



WELDERS PENS SILVER-STREAK

- Convenient Dispenser Pen with Push-Button Advance
- Superior to Chalk: Won't Rub or Burn Off
- Highly Visible Marks Remain Visible During Cutting or Welding
- Built-in Sharpener in Cap
- Durable marks will not scratch or abrade metal surfaces
- Perfect for layout marking prior to cutting / welding / fitting
- Marks: Mild steel and most metals
- Designed to Mark in All Conditions - Even Oily, Rusty or Wet Surfaces



Part No.	Description	Unit
P6-SSP	Pen	Pkt 1
P6-SSR	Refills Pkt 6	Pkt

MARKER PENS TRADES-MARKER

- Smooth Writing, Non-Toxic Grease Marker in Convenient Holder
- Highly Visible on Galvanized Steel, Stainless-Steel and Aluminium, where other markers have poor visibility
- Provides Weather and Rub-Resistant Marks.
- Perfect on plastic, glass, metal, wood and stone

Hi-Vis marks... popular for gal, stainless, aluminium



Part No.	Description	Unit
P6-TMP	Pen - with 5 Refills	Pkt
P6-TMRO	Refills Pkt 6 Orange	Pkt 6
P6-TMRB	Refills Pkt 6 Black	Pkt 6



PAINT PENS PRO-LINE HP - LOW CORROSION

- Unsurpassed Writing on Challenging Surfaces: Oily, Damp, Rusty, Coated & more
- Low-Chloride / Low-Corrosion Formula = Safe for use on Stainless Steel, Alloys and other special metals and will not contribute to unwanted corrosion, degradation, or pitting from use
- Highly Visible, Extremely Durable Permanent Paint that dries quickly and resists wearing or fading
- Made in USA
- ClipGrip Knurled Cap = Easy removal when wearing gloves or with greasy hands, will not roll on flat surfaces
- Marking Temp Range: -46c to 66c
- Industries: Metal Fabrication, Oil/Gas, Power/Energy, Shipbuilding, Aerospace, Nuclear
- Marks On: All Metals, Masonary, Plastic, Glass, Ceramic, Rubber & More
- 3mm Medium Bullet Tip

Best seller!
Safe, Low-corrosion & Highly
Durable marks



Part No.	Description	Unit
6-M96960/12	White	Box 12
6-M96961/12	Yellow	Box 12
6-M96963/12	Black	Box 12
6-M96962/12	Red	Box 12
6-M96965/12	Blue	Box 12
6-M96966/12	Green	Box 12
6-M96830/12	Pink	Box 12

Why choose...

PRO-LINE HP PAINT PENS

- **For demanding industrial applications**
- **Low-Chloride Formula for safe marking on stainless steel**
- **Chemical Analysis data available on request**
- **Firm Adhesion and Wear-Resist marking on a wide range of surfaces**

check out...



BL PAINTSTIK BLEED-THRU

- Marks bleed through solvent-based or oil-based paints.



Popular for marking structural steel

Part No.	Description	Unit
6-M80725/12	Blue (Bleeds Thru Top-Coat of paint)	Box 12

B PAINTSTIK GENERAL PURPOSE

- Real lead-free paint in stick form; combines long-lasting durability of paint with the ease-of-use of a crayon
- Weather-resistant, UV-resistant
- Marks through oil and water
- Marks on smooth, rough, rusty or dirty surfaces
- For use on metal, wood, plastic, concrete, rubber, glass, cardboard and paper

Real Paint in stick form... clean, quick, convenient!



Part No.	Description	Unit
6-M80220/12	White (General Purpose)	Box 12
6-M80221/12	Yellow (General Purpose)	Box 12

PAINT PENS CARDED

- Real paint with valve-actuated tip
- Individually Packaged / Carded for low-volume use
- Fast-drying permanent marks on all surfaces



Part No.	Description	Unit
P6-PMB	Black Valve-Action (Carded)	Pkt 1
P6-PMR	Red Valve-Action (Carded)	Pkt 1
P6-PMW	White Valve-Action (Carded)	Pkt 1
P6-PMY	Yellow Valve-Action (Carded)	Pkt 1

INK MARKERS DURA-INK

- Black ink contains low halogens
- Ink formulated for industrial strength usage
- Low-Chlorides / Low-Corrosion Formula - for peace of mind when using on Stainless-Steel & other sensitive applications
- Use on cardboard, wood, metal, paper, ceramics, cloth, glass, etc



Part No.	Description	Unit
6-M96223/12	Dura-Ink 25 (3x6mm Chisel) Black	Box 12
6-M96023/12	Dura-Ink 15 (1.5mm Bullet) Black	Box 12



TEMPERATURE INDICATION MARKERS THERMOMELT

- Fast, Accurate & Cost-Effective method of measuring surface temperatures
- Sticks are up to 50% Larger than other brands = Longer Lasting & Stronger
- Handy metal dispenser with pocket clip
- Made in USA

HOW DOES IT WORK?

- Initial mark appears dull & chalky. When desired temperature is reached, the mark quickly melts to a glossy transparent-appearing liquid
- Mark can be applied prior to heating, or the marker can be touched on the job during heating

APPLICATION INFO:

- Ideal for Heat Treating, Pre-Heating, Forging, Annealing, Welding & more



Part No.	Description	Unit
6-TS050	0050c	Each
6-TS075	0075c	Each
6-TS100	0100c	Each
6-TS125	0125c	Each
6-TS150	0150c	Each
6-TS175	0175c	Each
6-TS200	0200c	Each
6-TS225	0225c	Each
6-TS250	0250c	Each
6-TS275	0275c	Each
6-TS300	0300c	Each
6-TS350	0350c	Each
6-TS400	0400c	Each
6-TS450	0450c	Each
6-TS500	0500c	Each
6-TS550	0550c	Each
6-TS600	0600c	Each
6-TS650	0650c	Each
6-TS700	0700c	Each
6-TS750	0750c	Each
6-TS800	0800c	Each
6-TS850	0850c	Each
6-TS900	0900c	Each
6-TS950	0950c	Each
6-TS1000	1000c	Each
6-TS1100	1100c	Each
6-TS1200	1200c	Each



MIG PLIERS

- Multipurpose plier ideal for use when mig welding
- 4 in 1: Wire cutting, Nozzle and tip removal, Nozzle cleaning & Light hammering



Part No.	Description	Unit
P6-MPLY	MIG Pliers	Each

CHIPPING HAMMERS

- Spring handle
- Hardened steel head

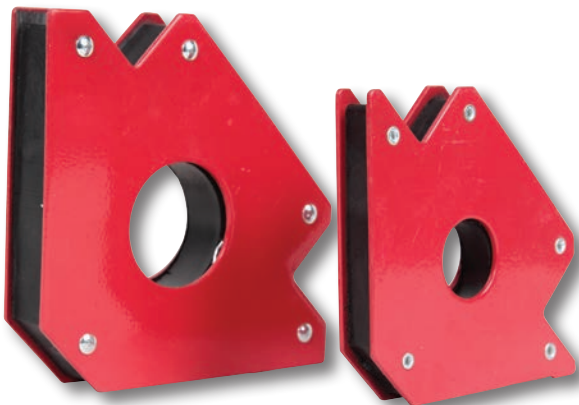


Part No.	Description	Unit
6-SHCH	Spring Handle	Each



MAGNETIC SQUARE RED ARROW

- 90 and 45 degree angle holding positions
- Assists Positioning of metal plates, brackets, etc when welding



Part No.	Description	Unit
P6-AMH4	4"	Each
P6-AMH5	5"	Each

MAGNETIC SQUARE STANDARD

- 90 and 45 degree angle holding positions
- Made in Australia
- Assists Positioning of metal plates, brackets, etc when welding



Part No.	Description	Unit
6-MSQ	Magnetic Square	Each



GOUGING TORCH PROMAX K4

- Robust, Dependable design
- Swivel head design
- 800 amp capacity
- Highly efficient metal removal, defect repairs, crack removal, edge preparation, etc
- Use with gouging carbon rods + DC power source + compressed air
- Use with 5mm - 13mm gouging carbons



Part No.	Description	Unit
6-K4GT	Torch Complete with 2m Cable	Each

ELECTRODE OVENS

- Keeps electrodes moisture-free for optimum weld quality and electrode performance
- Round/Cylindrical Chamber keeps electrodes in better condition & avoids flux chipping, unlike Square shaped ovens where electrodes tend to roll from one corner to another and are more readily damaged
- Lightweight - less than 4kg (unloaded) = Reduced strain on operator
- Variable temperature

APPLICATION INFO:

- Commonly used with Low-Hydrogen electrodes, so that low-hydrogen status is not compromised through moisture contamination
- Suitable for all types of electrodes



Part No.	Description	Unit
6-5KGEO	5kg Capacity 240v, 50-220c	Each
6-10KGEO	10kg Capacity 240v, 50-220c	Each



ANTI-SPATTER AEROSOL

- Effective spray to prevent weld spatter adhering to metal surfaces and mig torch parts
- Non-Toxic, Non-Flammable
- Paintable - No Silicone

*Super-Safe,
No-Hassle
Formula!*



Part No.	Description	Unit
9-AAS	454g	Each

ANTI-SPATTER NOZZLE DIP GEL

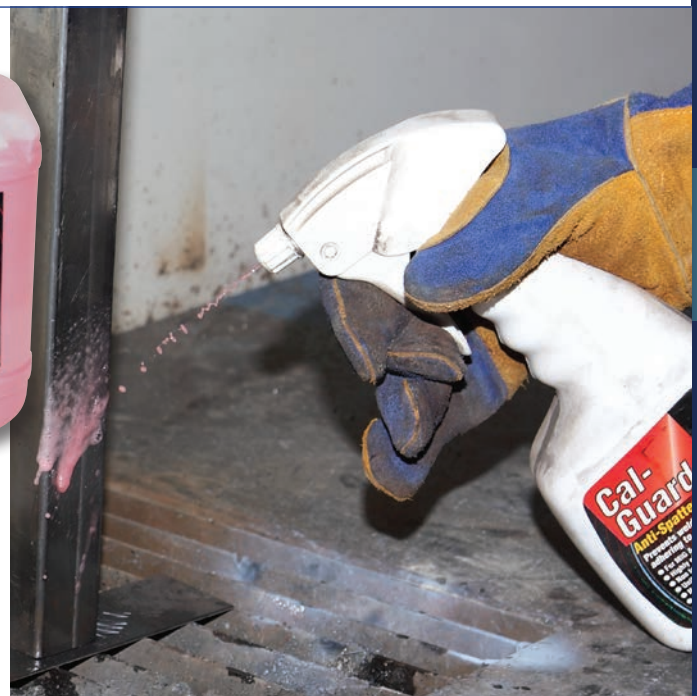
- Advanced non-toxic gel formula
- 400g Metal Tin
- Helps maintain optimum gas coverage
- Advanced gel designed to stop spatter adhering to mig torch parts



Part No.	Description	Unit
9-NDG	400g Metal Tin	Each

ANTI-SPATTER FLUID

- Designed to stop spatter adhering to metal surfaces
- Water based & Non - toxic
- Paintable
- With anti - rust properties
- Can be diluted if required (1:1)
- Quality Australian made



Part No.	Description	Unit
9-AS2	750ml Spray Bottle	Each
9-AS3	5L Container	Each
9-AS4	20L Container	Each

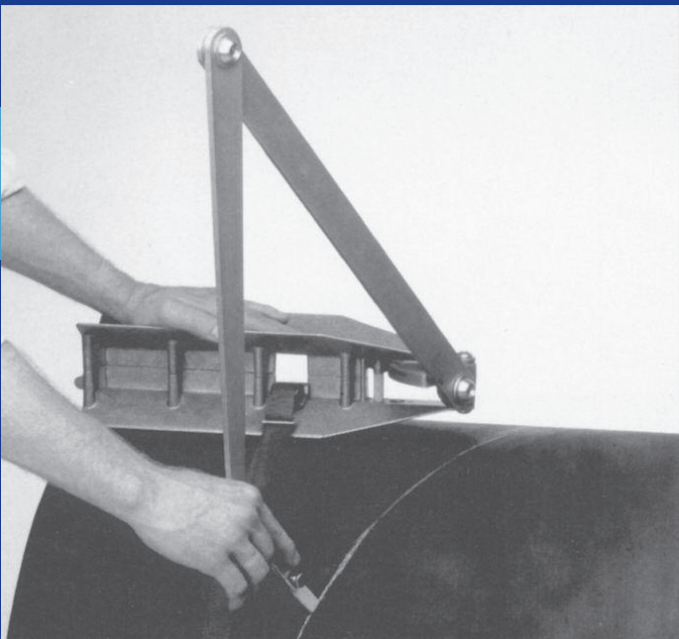


Introducing... Jackson® Contour® Pipe Tools

WELDCLASS IS YOUR OFFICIAL
CONTOUR SUPPLIER FOR AUSTRALIA

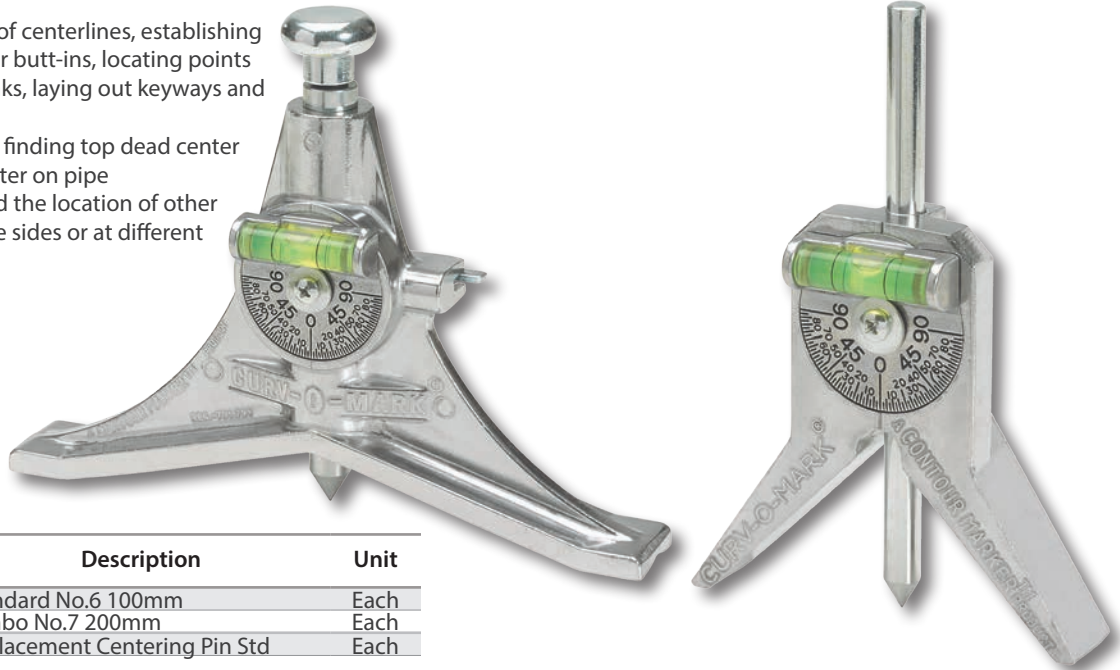


Check out the
Contour Video



CENTERING HEADS CONTOUR

- Aids in the settings of centerlines, establishing angles and marks for butt-ins, locating points inside pipes and tanks, laying out keyways and measuring declivity
- Used most often for finding top dead center or bottom dead center on pipe
- You can use it to find the location of other ordinate lines on the sides or at different angles.



Part No.	Description	Unit
KC-J1879	Standard No.6 100mm	Each
KC-J1880	Jumbo No.7 200mm	Each
KC-J1906	Replacement Centering Pin Std	Each

RADIUS MARKERS CONTOUR

- Easy circle & radius marking
- Sturdy friction joints to maintain rigidity and accuracy
- Made from lightweight, rustproof aluminum for long wear



Part No.	Description	Unit
KC-J1884	Mini, 200mm Radius	Each
KC-J1885	Small, 500mm Radius	Each
KC-J1886	Standard, 600mm Radius	Each
KC-J1887	Jumbo, 1000mm Radius	Each



WRAP-A-ROUNDS CONTOUR

- Inexpensive tool for marking straight lines around pipe, or for use as a straight edge
- Printed with scale, pitch chart, tangent chart and other useful markings
- Withstands service temperature of up to 180°C (350°F)

WRAP SIZE:

- 164B Medium: 100 x 1220mm (3.88in x 4ft)
- 176B Large: 100 x 1830mm (3.88in x 6ft)
- 177B XL: 125 x 2130mm (5in x 7ft)
- 179B XXL: 125 x 2740mm (5in x 9ft)

SUITS PIPE SIZE:

- 164B Medium: 75-150mm (3-6 in) double-wrap, or up to 320mm (13 in) single wrap
- 176B Large: 75-250mm (3-10 in) double-wrap, or up to 480mm (19 in) single wrap
- 177B XL: 100-300mm (4-12 in) double-wrap, or up to 560mm (22 in) single wrap
- 179B XXL: 150-405mm (6-16 in) double-wrap, or up to 720mm (28 in) single wrap



Part No.	Description	Unit
KC-J1858	164b Medium 100x1220mm	Each
KC-J1859	176b Large 100x1830mm	Each
KC-J1860	177b XL 125x2130mm	Each
KC-J1861	179b XXL 125x2740mm	Each

DIAL ANGLE FLANGE LEVEL CONTOUR

- Versatile tool that can be used as a dial degree utility level or, with attachments, for two-holing flange alignment.
- Saves time, Easy to use
- Fitted with a threaded, self aligning conical spacer and conical nut and bolt units for fastening the Level to a pipe flange
- One of the nut and bolt units is stationary, while the other slides up to 140mm (5-1/2 in) along a slot in the level to accommodate various flange bolt hole spacings from 50mm (2 in) to 140mm (5-1/2 in)



Part No.	Description	Unit
KC-J1891	Dial Angle Flange Level No.20	Each



UNIVERSAL LEVEL (MAGNETIC) CONTOUR

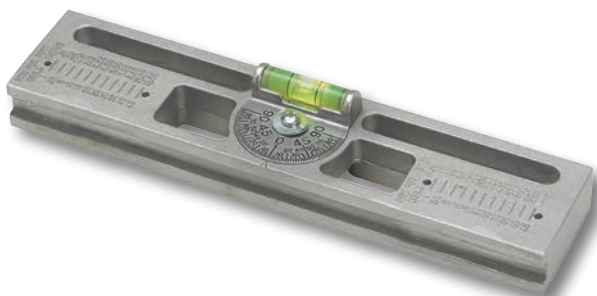
- Valuable Multi-purpose tool for assisting in a range of pipefitting tasks
- Adjustable 360DG protractor-dial level allows use in any position
- Magnetic



Part No.	Description	Unit
KC-J1904	Universal Level No.33	Each

CONTOUR PRO-MAG LEVEL CONTOUR

- Lightweight, easy to use tool for determining and setting up angles
- Ideal for pipefitters and welders
- Magnetic
- 360-degree adjustable dial leve (DSL) with two 90-degree quadrants graduated in 2-1/2-degree increments
- Cast in are tables used to convert degree-of-angle to rise-in-inches-per-foot or millimeters-per meter



Part No.	Description	Unit
KC-J1881	Pro-mag Level No.8	Each

DIAL AND LEVEL CONTOUR

- Adjustable bubble dial protractor level used with a number of Contour Curv-O-Mark Tools
- The protractor covers 180 degrees through two 90 degree quadrants, reading in 2.5 degree increments
- Bubble is cast in the aluminum dial



Part No.	Description	Unit
KC-J1905	Dial & Level No.dsl	Each



CONTOUR MARKERS CONTOUR

- Compact, time-saving tool used for lay out marking of pipe and structural steel joints.
- Laterals at any angle, tees, wyes, crosses, elbows-any type or size of joint can be quickly and precisely laid out
- No more complicated formulas, trial and error, or wasted materials



Part No.	Description	Unit
KC-J1874	Standard No.1	Each
KC-J1877	Jumbo No.4	Each

CIRCLE ECLIPSE PROJECTOR CONTOUR

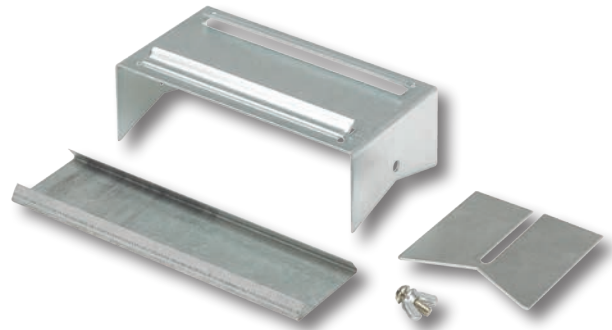
- Features a protractor with sliding rods & adjustable lever to lock in the specified layout
- A strong, 20-pound pull magnetic base holds the Projector in position during layout
- A durable web strap (included) holds the unit secure on non magnetic surfaces and can be used on either side of the vertical column



Part No.	Description	Unit
KC-J1888	Circle Eclipse Projector No.14	Each

COMBINATION ADAPTORS CONTOUR

- Optional accessory for Contour Markers to simplify handling and increase layout capacity
- Allows layouts with compound angles using a just one setting or any degree of take-off on elbows and turns up to 90 degrees

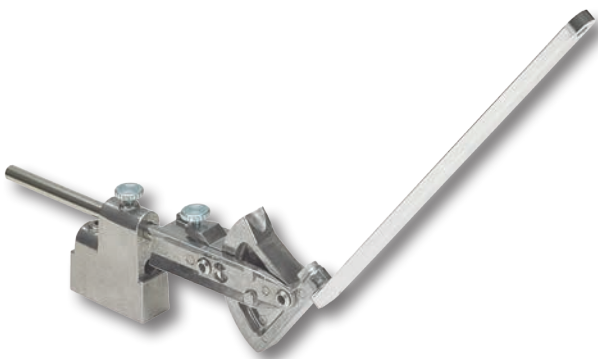


Part No.	Description	Unit
KC-J1875	Standard No.2	Each
KC-J1878	Jumbo No.5	Each



PROTRACTOR (MAGNETIC) CONTOUR

- Handy tool for use in making and checking angles, particularly in pipe layout
- Saves time, easy to use
- Magnetic base



Part No.	Description	Unit
KC-J1882	Protractor No.9	Each

MULTI TRAMMEL HEADS CONTOUR

- Radius Marking points designed to fit to standard 1/2 in (12.7mm) pipe
- The most accurate means of drawing arcs and circles because you can lock the radius tight.
- Save room in your tool box - use any standard 1/2-in pipe or conduit on the job site to create the radius you need



Part No.	Description	Unit
KC-J1890	Multi Trammel Heads No.19	Each

PIPE FLANGE ALIGNER CONTOUR

- Self-determining flange aligning tool for fast & accurate pipe construction
- Inserts easily into pipe, centers snugly against the inside pipe diameter and automatically aligns with the pipe axis
- Save time, easy to use



Part No.	Description	Unit
KC-J1883	Pipe Flange Aligner No.10	Each

FLANGE ALIGNER BASE CONTOUR

- Easier flange aligning and squaring
- Holds a square in the needed position without tying up one's hands
- Saves time, easy to use
- Magnetic



Part No.	Description	Unit
KC-J1903	Flange Aligner Base No.32	Each



SAFETY; EYE, EAR & RESPIRATORY

A quick look at...

PROMAX 500... WHAT OTHER WELDERS SAY

Great comfy helmet big screen is awesome and the price is right

Great Helmet so far..... lightweight, sensitive, and love the oversize viewing area.

Great helmet, love the field of view and fitting style

Comfortable fit. Love the big viewing area.

The screen size is unreal for the price I paid ... Excellent quality too!

Beautiful helmet to use

At last somebody has supplied a helmet with a large screen at an affordable price... Well done!

Fantastic helmet, can't wait to get welding again.

The Promax 500 is fantastic, large screen, so much better than my old helmet...thank-you

See Page 106



A HELMET FOR EVERY FABRICATOR



	WELDCCLASS Promax 200	WELDCCLASS Promax 350	WELDCCLASS Promax 500	WELDCCLASS Promax 400R	JACKSON WH70	JACKSON WH70 AIRMAX
MIG & Stick	Yes	Yes	Yes	Yes	Yes	Yes
TIG	-	Yes >30Amps	Yes >5Amps	Yes >5Amps	Yes >1Amp	Yes >1Amp
Grind Mode	Yes	Yes	Yes	Yes	Yes External Switch	Yes External Switch
Shade Range	9-13	9-13	5-8/9-13	9-13	6-8/9-13	6-8/9-13
View Area	96 x 39mm	100 x 53mm	98 x 87mm	96 x 48mm	96 x 69mm	96 x 69mm
Sensors	2	4	4	2	2 + Intelligent Sensing	2 + Intelligent Sensing
Optical Rating	1/1/1/2	1/1/1/2	1/1/1/2	1/1/1/2	1/1/1/1 World First	1/1/1/1 World First
Powered Respirator	-	-	-	Yes	-	Yes
Warranty <small>*on auto Lens</small>	1yr	2yr	2yr	3yr	5yr	5yr
Indicative \$ excl. GST	\$89.00	\$139.00	\$180.00	\$999.00	\$599.00	\$1,699.00

Phone 1300 784 200 for your nearest Distributor



**WELDING HELMET
PROMAX 200**

*Affordable, reliable,
great value!*

1 year Warranty

Light weight & comfortable

Ultra-Clear Vision

Manifiction Lens Holder

Grind-Mode

Locks the lens in light shade at the flick of a switch.



**Shade 9-13, Sensitivity
& Delay Adjustments**
Precise & easy-to-use
controls

- Ideal for MIG & Stick Welding
- Fast & easy cover lens replacement
- "Full Laminate" lens construction: Each layer in lens assembly is laminated for superior optical quality and reliability

INDICATIVE PRICE

\$89⁰⁰ Excl GST*

For your nearest Distributor
Phone 1300 784 200

*Prices are indicative only and may vary depending on volumes, freight cost, models/options & other factors

Part No.	Description	Unit
WC-05311	Promax 200 Silver	Each



**WELDING HELMET
PROMAX 350**

Upgrade to larger view, 4 sensors & ultra-clear vision!

2 year Warranty

Ultra Clear Vision

4 Arc Sensors
for reliable arc detection & switching

Generous Viewing Area
Larger than many other helmets in this class (100 x 53mm)

Reliable Power Source
Replaceable battery, solar assist, efficient electronics for low power consumption

Manification Lens Holder

Light Weight & Comfortable

AS1337.1 High-Impact Rated
A must for many work sites

Grind-Mode
Locks the lens in light shade at the flick of a switch.



Shade, Sensitivity & Delay Adjustments
Precise & easy-to-use controls

INDICATIVE PRICE
\$139⁰⁰ Excl GST*

For your nearest Distributor
Phone 1300 784 200

*Prices are indicative only and may vary depending on volumes, freight cost, models/options & other factors

- Ideal for MIG & Stick Welding, also suits TIG welding down to 30 amps
- Fast & easy cover lens replacement
- "Full Laminate" lens construction: Each layer in lens assembly is laminated for superior optical quality and reliability
- Bonus helmet bag

Part No.	Description	Unit
WC-05313	Blue	Each
WC-05314	Fire Metal	Each



**WELDING HELMET
PROMAX 500**

85cm² of
ultra-clear
vision!

2 year Warranty

4 Arc Sensors
for reliable arc detection & switching

Super-size Viewing Area
98 x 87mm

Reliable Power Source
Replaceable battery, solar assist, efficient
electronics for low power consumption

Manifaction Lens Holder

Light Weight & Comfortable

AS1337.1 High-Impact Rated
A must for many work sites

Shade, Sensitivity & Delay Adjustments
Precise & easy-to-use controls



Grind-Mode
Locks the lens in light shade
at the flick of a switch.

INDICATIVE PRICE
\$180⁰⁰ Excl GST*

For your nearest Distributor
Phone 1300 784 200

*Prices are indicative only and may vary
depending on volumes, freight cost,
models/options & other factors

- For MIG, Stick Welding & TIG welding down to 5 amps
- Fast & easy cover lens replacement
- "Full Laminated" lens construction: Each layer in lens assembly is laminated for superior optical quality and reliability
- Bonus helmet bag

Part No.	Description	Unit
WC-05317	Black Stealth	Each



WELDING HELMET WITH POWERED AIR RESPIRATOR PROMAX 400R

Digital Lens

Shade, sensitivity, delay and grind-mode controls
3 Year lens Warranty



*Affordable & professional
clean air*

Promax R20 Powered Respirator System

Battery powered, lightweight.
P3 Class Respirator to protect from harmful welding fumes

8 Fan Speed Settings

For optimum comfort and battery life

Affordable & Reliable

Industrial quality - tried, tested & proven world-wide

100% Solar Powered

No batteries to replace, no on/off buttons, ready to weld at any time

Exceptionally Lightweight Reduced operator Fatigue

- For MIG, Stick & TIG down to 5 amps
- Magnification Len Holder

PACKAGE INCLUDES:

- Promax 400R Helmet with air duct & hood
- Promax R20 Powered Respirator blower & hose
- Battery Charger
- Comfort Belt
- Quality Kit Bag



INDICATIVE PRICE

\$999⁰⁰

Excl GST*

For your nearest Distributor
Phone 1300 784 200

*Prices are indicative only and may vary depending on volumes, freight cost, models/options & other factors



Part No.	Description	Unit
WC-05158	Promax 400 Helmet with R20 Respirator Package	Each



Jackson® WH70 Welding Helmets

World's Best Vision*...



Balder® Technology

World-leading auto-darkening technology.
Developed & Manufactured in Europe since 1979

1/1/1/1

World's best optical rating*

* Best possible rating under EN379 standard. Balder technology is first ever to achieve this

5 Year Warranty

World-leading reliability

What Welder's Say

"I found the helmet lens so clear I can even see the weld pool and watch if porosity forms... I was used to just seeing blurs of light with my old helmet. Best helmet I've worn" - Genuine WH70 Owner's comment.

Technology Comparison

Other Brand

Jackson WH70



Light



Light/Grind Mode



Dark/Welding



Dark/Welding



WELDING HELMET JACKSON WH70 GDS

Superior European Quality & Reliability
For operators who demand the absolute best!

*World's best vision...
1/1/1/1 rating!*

5 Year Warranty
On Auto-darkening lens

Low-Profile External Controls
No need to remove helmet to adjust settings

100% Solar Powered
No batteries to replace, no on/off buttons, ready to weld at any time

World's first 1/1/1/1 Optical Rating
Clarity of Vision second to none

Wide-View Lens

Tested & Conforms to:
AS1337.1 High-Impact (helmet)
and AS1338.1 (lens)

INDICATIVE PRICE
\$599⁰⁰
Excl GST*

For your nearest Distributor
Phone 1300 784 200

*Prices are indicative only and may vary depending on volumes, freight cost, models/options & other factors

- For the serious professional & Industrial Applications
- For MIG, TIG & Stick, including low-amp TIG down to 1 amp



- A. DELAY adjusts time from dark to light state
- B. SHADE ADJUSTMENT 6-8 / 9-13
- C. GRIND MODE FUNCTION
- D. SENSITIVITY adjusts to suit all welding environments



Jackson '375' Headgear
Comfortable, robust, easy to adjust



Hard-Hat System
See page 111

Part No.	Description	Unit
KC-J9916	Helmet - WH70 GDS	Each



**WELDING HELMET WITH POWERED AIR RESPIRATOR
JACKSON WH70 GDS + AIRMAX ELITE**

Superior European Quality & Reliability

For operators who demand the absolute best!

WH70 GDS Helmet

See previous page for helmet details

Jackson '375' Headgear

Comfortable, robust, easy to adjust

Integrated Duct System

Tidy, Compact, No loose parts

'TH3' Rated Filter

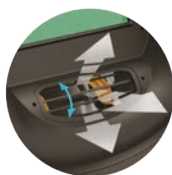
Highest possible rating for filter efficiency and air purity

Unique Face Seal System

Push face into seal, pull face out to remove.
Ultra-comfortable, no hoods or strings

Air Outlet

Located directly in breathing zone. Adjustable vent



The ultimate Air-Fed Helmet package!

External Controls including Grind Mode

No need to remove helmet. Exceptional clarity of vision eliminates need to flip up helmet when grinding



'Airmax Elite' Respirator System

Advanced, Low-Profile & Light Weight. Up to 10 hours battery life. Dual filters for long life.

Tested & Conforms to AS1716

INDICATIVE PRICE

\$1,699⁰⁰ Excl GST*

For your nearest Distributor
Phone 1300 784 200

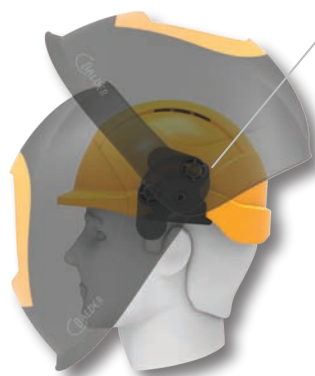
*Prices are indicative only and may vary depending on volumes, freight cost, models/ options & other factors

- For the serious professional & Industrial Applications
- For MIG, TIG & Stick, including low-amp TIG down to 1 amp

Part No.	Description	Unit
KC-J5225/K	Helmet WH70 GDS Air + Airmax Elite Sytem	Each

HARD-HAT KIT FOR JACKSON WH70 WELDING HELMETS

- Hard-Hat and Adaptor Kit
- Specifically engineered to suit Jackson WH70 Helmets, for perfect balance and fit



Light, Comfortable & Well Balanced
Easy to wear, even for long periods

INDICATIVE PRICE

\$199⁰⁰ Excl GST*

For your nearest Distributor
Phone 1300 784 200

*Prices are indicative only and may vary depending on volumes, freight cost, models/options & other factors



Functional & Robust

Firm attachment to Hard-Hat.
Easily attaches or detaches.



High Quality Hard-Hat
Ratched style Headgear for firm fit. Made in Europe

Easy to Fit

Remove existing Headgear,
replace with adaptor kit

Part No.	Description	Unit
KC-J5234/K	Hard-Hat with Adaptor Kit	Each



MAGNIFICATION LENS HOLDER FOR JACKSON WH70 HELMETS

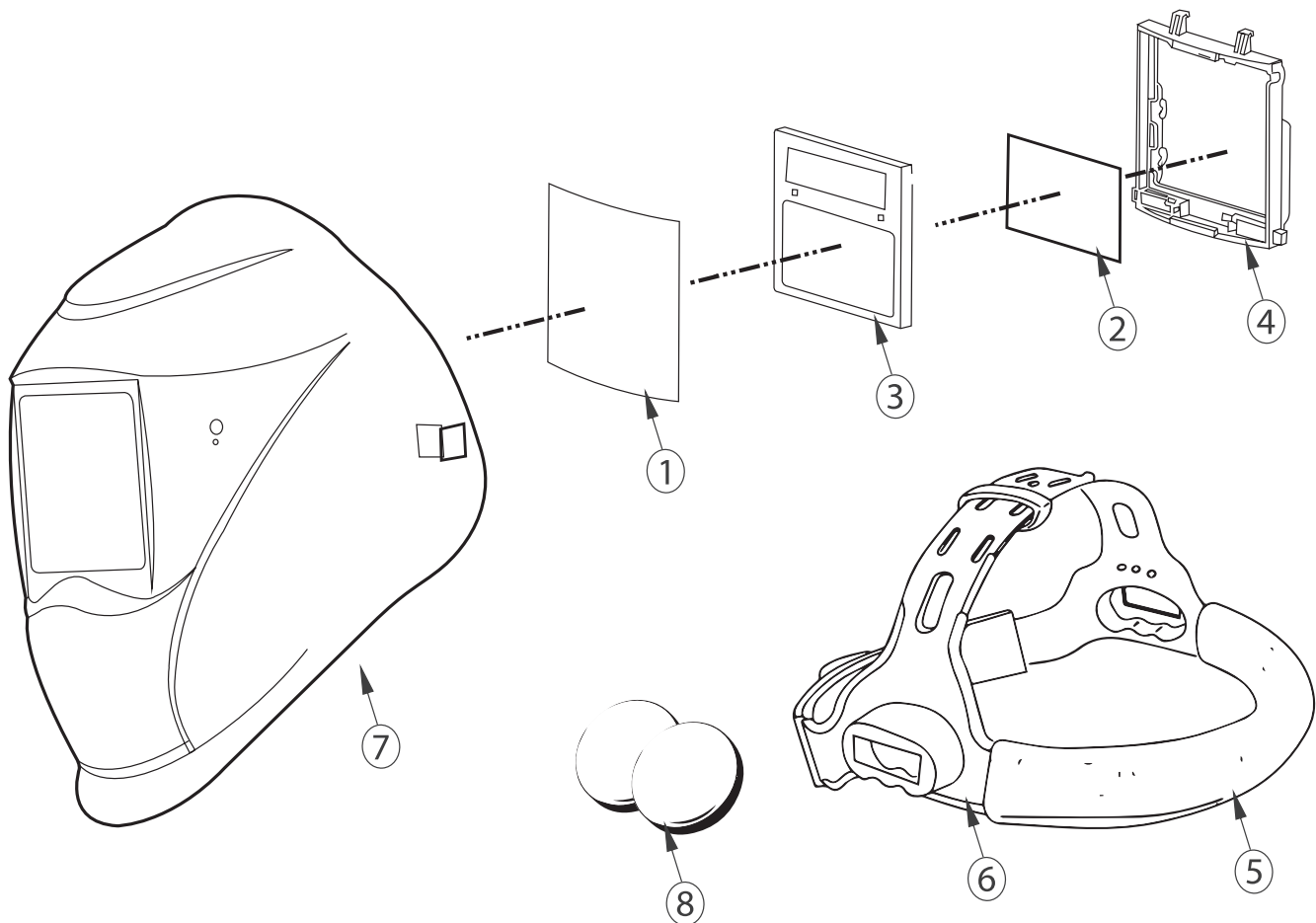
- Adaptor frame to enable fitting of Magnification lens to Jackson WH70 welding helmets
- Fits to inside of Helmet



Part No.	Description	Unit
KC-J9936	Mag Lens Holder	Each



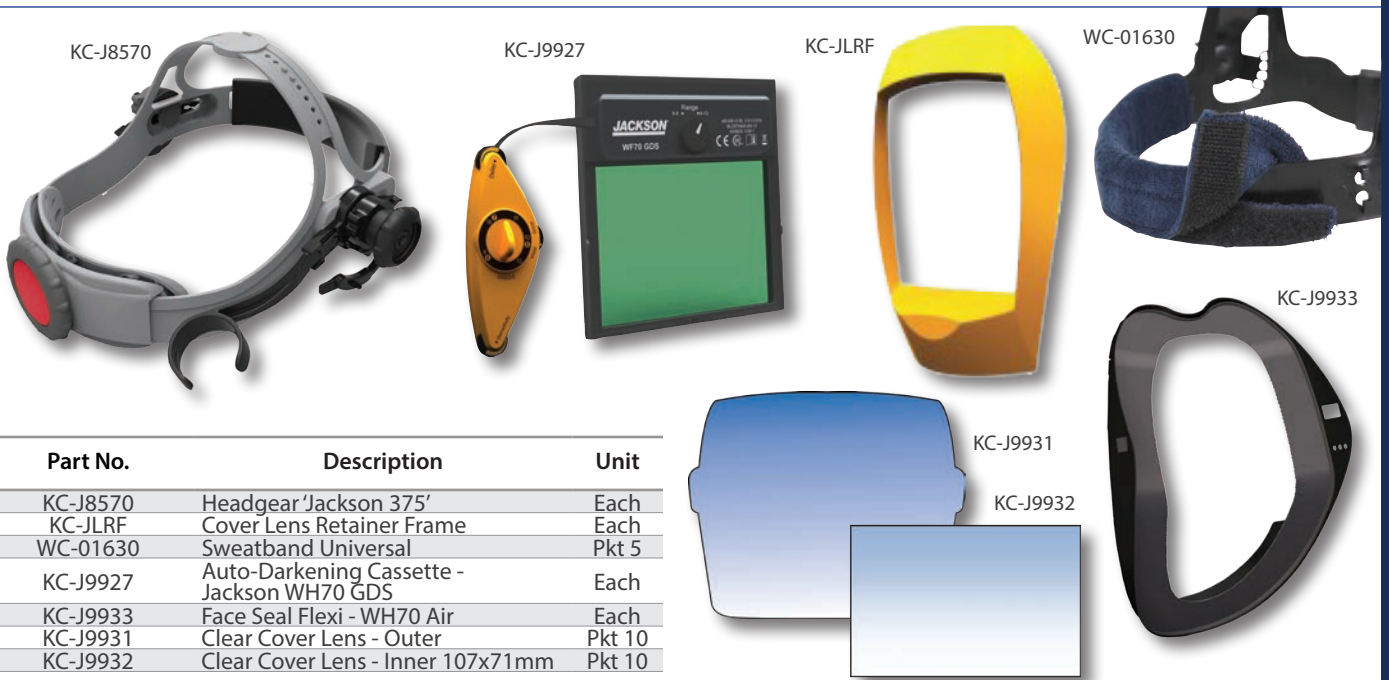
SPARE PARTS FOR WELDCLASS WELDING HELMETS



Part No.	Description	Helmet Model	Ref	Unit
See page 115	Cover Lens – Outer	See page 115	1	
See page 115	Cover Lens – Inner	See page 115	2	
WC-05327	Auto-Darkening Lens Cassette	Promax 200	3	Each
WC-05328	Auto-Darkening Lens Cassette	Promax 350	3	Each
WC-05175	Auto-Darkening Lens Cassette	Promax 400	3	Each
WC-05329	Auto-Darkening Lens Cassette	Promax 500	3	Each
WC-05330	Lens Retainer Frame	Promax 200, 350	4	Each
WC-05331	Lens Retainer Frame	Promax 500	4	Each
WC-01630	Sweatband	Promax 200, 350, 500	5	Pkt 5
P7-M3SB	Sweatband	Promax 300, Platinum 600	5	Each
WC-05172	Sweatband	Promax 400R (respiratory)	5	Each
WC-01629	Sweatband	Flip-Front	5	Each
WC-05325	Headgear	Promax 200, 350, 500	6	Each
7-M3HG	Headgear	Promax 300, Platinum 600	6	Each
WC-05165	Headgear	Promax 400 (includes air duct)	6	Each
7-M2HG	Headgear	Mach 2, 4	6	Each
7-FFHG	Headgear	Flip-Front	6	Each
WC-05174	Shell + Headgear + Face Seal	Promax 400R (respiratory)	7	Each
WC-03987	Battery – CR2032	Promax 300, 350, 500	8	Each
WC-02640	Battery – CR2450	Promax 500, Platinum 600, Mach2, Mach6	8	Each



**SPARE PARTS
FOR JACKSON WH70 WELDING HELMETS**



Part No.	Description	Unit
KC-J8570	Headgear 'Jackson 375'	Each
KC-JLRF	Cover Lens Retainer Frame	Each
WC-01630	Sweatband Universal	Pkt 5
KC-J9927	Auto-Darkening Cassette - Jackson WH70 GDS	Each
KC-J9933	Face Seal Flexi - WH70 Air	Each
KC-J9931	Clear Cover Lens - Outer	Pkt 10
KC-J9932	Clear Cover Lens - Inner 107x71mm	Pkt 10

**SPARE PARTS
FOR JACKSON AIRMAX ELITE RESPIRATOR**



Part No.	Description	Unit
KC- J5257	Main Filter	Pkt 2
KC-J5259	Pre-Filter Standard	Pkt 10
KC-J5276	Pre-Filter Carbon	Pkt 10
KC-J5262	Filter Cover Assy	Pkt 2
KC-J5223	Battery	Each
KC-J5256	Battery Charger	Each
KC-J5254	Belt	Each
KC-J5255	Breathing Hose	Each



SPARE PARTS FOR PROMAX R20 POWERED AIR RESPIRATOR

- Parts for Promax R20 Respirator as used with Promax 400R Welding Helmet



Part No.	Description	Unit
WC-05168	Air Hose with cover	Each
WC-05169	Battery Charger	Each
WC-05166	Battery	
WC-05167	Blower Unit Only (does not include battery or filter)	Each
WC-05171	Filter - Main Filter	Each
WC-05170	Filter - Pre-Filter	Pkt 10
WC-05190	Pre-Filter Carbon	Pkt 10
WC-05173	Waist Belt	Each

SWEATBANDS UNIVERSAL

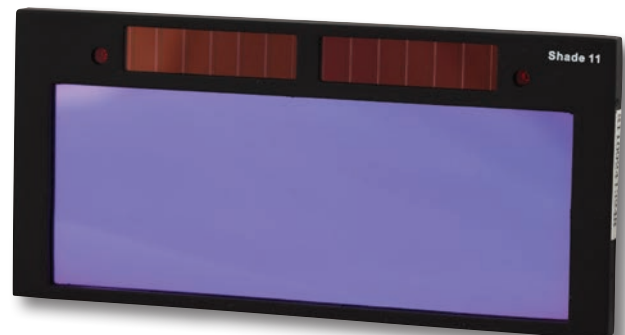
- Universal Velcro style Fit - Suit Almost Any Helmet
- Heavy-Duty Multi-Layered Towelling for Long-Lasting Comfort



Part No.	Description	Unit
WC-01630	PROMAX SB2 Sweatbands - Towel/ Velcro Style	Pkt 5

AUTO DARKENING LENS PROMAX 100

- Fits standard flip-front helmets
- Solar powered
- Shade 11
- Suitable for MIG and Stick/MMA
- 12 month Warranty



Part No.	Description	Unit
WC-04094	Shade 11 - 108x51mm suit Std F/ Front Helmet	Each



HELMET FLIP FRONT

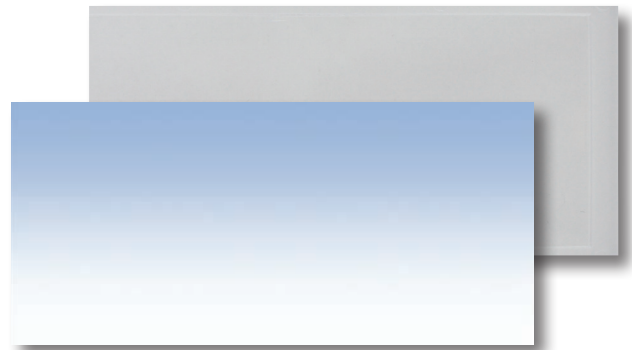
- Complies with AS1337
- Takes Standard 108x51mm Lenses



Part No.	Description	Unit
7-FFH	Flip Front Helmet (AS1337 Medium Impact)	Each

CLEAR LENSES FOR STANDARD FLIP-FRONT HELMETS

- Suits most common Flip-front Helmets
- Size 108 x 51mm - suits most standard flip-front helmets
- 7-CL39 'CR39 Style' Spatter Resistant
- 7-CLPC Polycarbonate Impact-Resistant



Part No.	Description	Unit
7-CL39	CR39 Style 108 x 51mm	Each
7-CLPC	Polycarbonate 108 x 51 x 2mm	Each

MAGNIFICATION LENSES 108 X 51MM

- Size 108 x 51mm - suits most standard flip-front helmets
- Available in 1.5,2.0 & 2.5 times magnification
- Improves clarity of vision



Part No.	Description	Unit
P7-ML15	1.5x Diopter	Pkt
P7-ML20	2.0x Diopter	Pkt
P7-ML25	2.5x Diopter	Pkt

SHADE LENSES 108 X 51MM

- Quality replacement glass shade lenses
- Size 108 x 51mm - suits most standard flip-front helmets



Part No.	Description	Unit
7-SL9	Shade 9	Each
7-SL10	Shade 10	Each
7-SL11	Shade 11	Each
7-SL12	Shade 12	Each



**CLEAR COVER LENSES
FOR WELDING HELMETS**

Find the right clear
cover lens for
your welding helmet
Fast!



See Reference Chart on
Following pages...

OR



weldclass.com.au/lens-search






















LENS REFERENCE CHART

HELMET BRAND*	HELMET MODEL*	LENS TYPE	CROSS REF.*	LENS DIMENSIONS	P/NO.	SHAPE
WELDCLASS	Promax 200	Outer		115 x 104mm	WC-05323	
		Inner		102 x 42mm	WC-05320	
	Promax 300 / Mach 3	Outer		133 x 114mm	P7-CL133114/10	
		Inner		107 x 54mm	P7-CL10754/5	
	Promax 350	Outer		115 x 104mm	WC-05323	
		Inner		106 x 59mm	WC-05321	
	Promax 400	Outer		110 x 90mm	P7-CL11090/10	
		Inner		107 x 51mm	P7-CL10751/5	
	Promax 500	Outer		137 x 117mm	WC-05324	
		Inner		105 x 92mm	WC-05322	
	Platinum 600 / Mach 6	Outer		133 x 114mm	P7-CL133114/10	
		Inner		106 x 63mm	P7-CL10663/5	
	Mach 4 (old model)	Outer		122 x 115mm	P7-CL122115/10	
		Inner		107 x 51mm	P7-CL10751/5	
Mach 2 (old model)	Outer	P7-M2OL10	122 x 102mm	P7-CLM2/10		
	Inner	P7-C2IL5	107 x 51mm	P7-CL10751/5		
ArcOne®	Cobra	Outer/Inner	EPEAOPCP1	110 x 90mm	P7-CL11090/10	
	Viper	Outer/Inner	EPEAOPCP2	114 x 133mm	P7-CL133114/10	
BOC®	Auto-Tracker / Switch / Multi-Process	Outer	5000-211	180 x 115mm	P7-CLOPS/5**	
		Inner	5000-328	107 x 51mm	P7-CL10751/5	
	See Also "WeldGuard" Brand					
Boss / Boss-Safe®	Top Dog	Outer	700228	120 x 98mm	P7-CLTD/10	
		Inner	700229	95 x 51mm	P7-CL9551/5	
	Blaze / Graphite / Urban / Street	Outer	700228	120 x 98mm	P7-CLTD/10	
		Inner	700235	103 x 69mm	P7-CL10369/5	
	Mega-View Series	Outer	700320	133 x 114mm	P7-CL113114/10	
		Inner	700321	104 x 96mm	TBA	
Speedy	Outer	700340	115 x 87mm	TBA		
	Inner	700342	103 x 53mm	P7-CL10353/10		
Cigweld®	Weldskill	Outer	454308	114 x 89mm	P7-CLCWS/10	
		Inner	454309	105 x 46mm	P7-CL10546/5	
	ProPlus+	Outer	454356	133 x 114mm	P7-CL133114/10	
		Inner	454357	97 x 65mm	P7-CL9765/10	



LENS REFERENCE CHART - CONT'D

HELMET BRAND*	HELMET MODEL*	LENS TYPE	CROSS REF*.	LENS DIMENSIONS	P/NO.	SHAPE
Cigweld®	ProLite	Outer	454329	123 x 98mm	WC-05157	
		Inner	454328	97 x 65mm	WC-05156	
	Arcmaster Pro	Outer	454298	110 x 180mm	P7-CLCAP/10	
		Inner	454299	107.8 x 51mm	P7-CL10751/5	
Esab®	New Tech 6-13 XL ADC Plus	Outer	0700 000 139	110 x 90mm	P7-CL11090/10	
		Inner	0700 000 268	107 x 71mm	KC-J9932	
	New Tech 9-13 ADC Plus	Outer	0700 000 139	110 x 90mm	P7-CL11090/10	
		Inner	0700 000 228	107 x 51mm	P7-CL10751/5	
	Aristo Tech	Outer	0700 000 010	115 x 95mm	P7-CL11595/10	
		Inner	0700 000 371	107 x 51mm	P7-CL10751/5	
Fronius®	Vizor Series	Outer	42.0510.0024	180 x 115mm	P7-CLOPS/5	
	Vizor 1000	Inner	42.0510.0019	107 x 51mm	P7-CL10751/5	
	Vizor 3000	Inner	42.0510.0092	107 x 54mm	P7-CL10754/5	
	Fazor 1000	Outer	42.0510.0112	137 x 126mm	WC-05056	
		Inner	42.0510.0092	107 x 54mm	P7-CL10754/5	
Jackson (Balder)	WH70 (BH3) GDS	Outer	P7-CLBD3/10	141 x 126mm	KC-J9931	
		Inner	P7-CL10771/10	107 x 71 mm	KC-J9932	
Kemppi®	Beta 60	Outer	9873252	110 x 60mm	P7-CL11060/10	
		Grinding Visor	9873254	110 x 90 x 1.5mm	P7-CL1109015/10	
	Beta 90	Outer	9873253	110 x 90 x 1.0mm	P7-CL11090/10	
		Grinding Visor	9873254	110 x 90 x 1.5mm	P7-CL1109015/10	
		Inner - Beta 90A	9873253	110 x 90 x 1.0mm	P7-CL11090/10	
		Inner - Beta 90X	9873251	107 x 51mm	P7-CL10751/5	
Lincoln®	Viking 700G & Power Craft Series	Outer	KP2913-1 / 94006943-1	112 x 91mm	P7-CL11291/10	
		Inner	KP2897-1 / 94006943-3	95 x 51mm	P7-CL9551/5	
	Viking 3350 Series (Large Lens)	Outer	KP2898-1	133 x 114mm	P7-CL133114/10	
		Inner	KP3044-1	94 x 89mm	P7-CL9489/5	
Liquidarc®	Dominator (old model)	Outer	LA-EH913-3P	102 x 122mm	P7-CLM2/10	
		Inner		107 x 51mm	P7-CL10751/5	

The replacement lenses advertised are original Weldclass products only, unless specifically indicated by this symbol **. Any brand names or trade names or part numbers shown other than Weldclass are the property of their respective owners and are shown for identification purposes only and are not in any way affiliated with Weldclass. E.&O.E.

















LENS REFERENCE CHART - CONT'D

HELMET BRAND*	HELMET MODEL*	LENS TYPE	CROSS REF.*	LENS DIMENSIONS	P/NO.	SHAPE
Miller® (See also 'WIA' brand)	Elite, Titanium 9400 / 9400i	Outer	216326P	145 x 120 mm	P7-CLME/10	
		Inner	216327P	106 x 63 mm	P7-CL10663/5	
	Titanium 9400i	Grinding Visor	245818		TBA	
	Performance	Outer	231921P	112 x 126mm	P7-CLMPF/10	
		Inner	770237P	107 x 51mm	P7-CL10751/5	
	Pro-hobby & Pro-hobby FS10 (old models)	Outer	231411P	115 x 95mm	P7-CL11595/10	
		Inner	770237P	107 x 51mm	P7-CL10751/5	
		Inner -early model	231410P	107 x 44mm	P7-CL10744/5	
	Flame & Xii (old models)	Outer	770240P	114 x 86mm	P7-CL11486/10	
		Inner	770237P	107 x 51mm	P7-CL10751/5	
	Xlix (old models)	Outer	770241P	116 x 96mm	P7-CLMXL/10	
		Inner	770237P	107 x 51mm	P7-CL10751/5	
NuWeld®	NWH3005	Outer	NWHOL	117 x 87mm	P7-CL11787/10	
		Inner	NWHIL2	94 x 45mm	P7-CL9445/5	
Optrel® (Sperian®)	Satellite, Orion, Mira Plus, OS100	Outer	5000.210 / 5000.212	180 x 115mm	P7-CLOPS/5**	
	p500 Series	Outer	5000.250 / 5001.250	137 x 126mm	WC-05056	
	e640, OSC, Satellite, Orion, Miraplus	Inner	5000.300	107 x 51mm	P7-CL10751/5	
	e650, e670, e680, p550, p530	Inner	5000.001	107 x 54mm	P7-CL10754/5	
	Galaxy	Inner / Outer	5000.227	107 x 51mm	P7-CL10751/5	
		Grinding Visor	5000.226	108 x 68mm	P7-CL10868/5	
	OSC, Twisty, Mira (old models)	Outer	5000.105	110 x 86mm	P7-CL11086/10	
Ross®	RXH100F	Outer	NWHOL	117 x 87mm	P7-CL11787/10	
		Inner	NWHIL1	90 x 42mm	P7-CL9042/5	
	RXH300S	Outer	NWHOL	117 x 87mm	P7-CL11787/10	
		Inner	NWHIL2	94 x 45mm	P7-CL9445/5	

The replacement lenses advertised are original Weldclass products only, unless specifically indicated by this symbol **. Any brand names or trade names or part numbers shown other than Weldclass are the property of their respective owners and are shown for identification purposes only and are not in any way affiliated with Weldclass. E.&O.E.


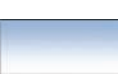

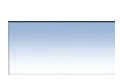







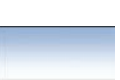








LENS REFERENCE CHART - CONT'D

HELMET BRAND*	HELMET MODEL*	LENS TYPE	CROSS REF.*	LENS DIMENSIONS	P/NO.	SHAPE
Servore / ServoGlas®	SV4000 / Arc Defender / Arc Protector	Outer	AD/APFCL	120 x 85mm	P7-CL12085/10	
		Inner	AD/APICL	109 x 47mm	P7-CL10947/5	
	SV5000 Auto-Lift	Outer	ALFCL	117 x 95mm	P7-CL11795/10	
		Inner	ALICL	107 x 51mm	P7-CL10751/5	
		Grinding Visor	ALIPL	268 x 89mm	P7-CLSV5GV/10	
Speedglas® (3M®)	9000/9002 Series & Utility	Outer	426000 / 420150 (also 427000 / 420100)	162 x 97mm	P7-CLSG9/10	
	Utility, 9000U/F/V, 9002V	Inner	428000 (420200)	90 x 42mm	P7-CL9042/5	
	9000X / 9002X series	Inner	428010 (420210)	103 x 53mm	P7-CL10353/5	
	100 series	Outer	776000 (also 777000)	148 x 86mm	P7-CLSG1/10	
		Inner	428000 (420210)	90 x 42mm	P7-CL9042/5	
	9100 series	Outer	526000 (also 527000)	155 x 96mm	P7-CLSG91/10**	
		Inner -9100V	528005	117 x 50mm	P7-CL11750/5	
		Inner -9100X	528015	117 x 61mm	P7-CL11761/5	
	9100-FX	Inner -9100XX	528025	117 x 77mm	P7-CL11777/5	
Grinding Visor		523000	225 x 110mm	P7-CLSG91FXV/5		
Tecmen®	NTADF100F	Outer	NTADF100F/SG	110 x 90mm	P7-CL11090/10	
	NTADF700S	Outer	NTADF700S/SG	110 x 90mm	P7-CL11090/10	
		Inner	NTADF700S/IG	95 x 51mm	P7-CL9551/5	
Top Dog	See Boss / BossSafe					
Unimig®	Razorback XA-5001 RazorWeld XA-5022	Outer	UMRBOP	133 x 114mm	P7-CL133114/10	
		Inner	UMRBIP	106 x 65mm	P7-CL10665/5	
	"UM" / XA-1001 Series Black, Aus-Ace, Graphic, Etc	Outer	UMOP	110 x 90mm	P7-CL11090/10	
		Inner	UMIP	103 x 47mm	P7-CL10347/5	
	Flame 5000X Auto-Lift	Outer	UMLOP	117 x 95mm	P7-CL11795/10	
		Inner	UMLIP	107 x 51mm	P7-CL10751/5	
		Grinding Visor	UMLPL	268 x 89mm	P7-CLSV5GV/10	
	Wide-View Aust Flag (Old model)	Outer	UMAOP	133 x 114mm	P7-CL133114/10	
Inner		UMAIP	106 x 63mm	P7-CL10663/5		



LENS REFERENCE CHART - CONT'D

HELMET BRAND*	HELMET MODEL*	LENS TYPE	CROSS REF**.	LENS DIMENSIONS	P/NO.	SHAPE
WeldGuard® (BOC®)	AUTOchange	Outer	WG4700	110 x 98mm	P7-CL11098/10	
		Inner	WG4701H	103 x 47mm	P7-CL10347/5	
	Auto-Tracker / Multi-Process	Outer	5000-211	180 x 115mm	P7-CLOPS/5	
		Inner		107 x 54mm	P7-CL10754/5	
	Galaxy	Inner / Outer		107 x 51mm	P7-CL10751/5	
		Grinding Visor		108 x 68mm	P7-CL10868/5	
Weldmaster®	Weldview WH1000	Outer	WH1000-ECL	110 x 90mm	P7-CL11090/10	
		Inner	WH1000-ICL	96 x 47mm	P7-CL9647/5	
	Weldview "Aussie Blue"	Outer	WH1000AB-ECL	112 x 91mm	P7-CL11291/10	
		Inner	WH1000AB-IL	95 x 51mm	P7-CL9551/5	
	Weldview WH720S	Outer	WH720S-3	118 x 108mm	P7-CL118108/10	
		Inner	WH720S-5	98 x 45mm	P7-CL9845/5	
	Weldview WH820S	Outer		133 x 114mm	P7-CL133114/10	
		Inner		94 x 89mm	P7-CL9489/5	
	Solar-Storm (WH2000)	Outer		110 x 90mm	P7-CL11090/10	
		Inner		107 x 51mm	P7-CL10751/5	
WIA®	WIA® Blue	Outer	235621P	102 x 122mm	P7-CLM2/10	
		Inner	770237P	107 x 51mm	P7-CL10751/5	

The replacement lenses advertised are original Weldclass products only, unless specifically indicated by this symbol **. Any brand names or trade names or part numbers shown other than Weldclass are the property of their respective owners and are shown for identification purposes only and are not in any way affiliated with Weldclass. E&O.E.

check out...

weldclass.com.au/lens-search



GOGGLES OXY

- Shade 5 Lenses
- Flip-up style
- Suitable for Oxy and Plasma work



Part No.	Description	Unit
P7-OGFF	Std Round Lenses	Pair
P7-OGFFL	Rectangular 108 x 51mm Lens	Pkt

SAFETY SPECS SHADE 5

- Snug wrap around fit for comfort and protection
- Shade 5 Oxy specs
- Suitable for most plasma and Oxy cutting operations



Part No.	Description	Unit
7-MS5	Shade 5 (For Oxy / Plasma)	Pair

FACE SHIELDS CLEAR

- Protection for Grinding, Chipping, etc
- AS1337.1 High-Impact Rated
- Suitable for workplaces that require High-Impact visors



Part No.	Description	Unit
7-FSC	Complete Faceshield - Clear	Each
7-FCV	Replacement Visor Only - Clear	Each

FACE SHIELDS SHADE 5

- Shade 5 for Oxy & Plasma Work
- Superior to Goggles or Specs: Protects the Whole Face from Arc Rays/Flash, Heat and Particles



Part No.	Description	Unit
7-FS5	Complete Faceshield - Shade 5	Each
7-F5V	Replacement Visor Only - Shade 5	Each



SAFETY SPECS ACE

- Low cost and stylish eye protection
- Close fitting wrap around design
- Full UV protection against sun glare
- Certified to AS/NZS 1337.1 - Medium impact



Part No.	Description	Unit
7-ACC	Clear	Pair
7-ACS	Smoke	Pair
7-ACA	Amber (Indoor / Light Enhancing)	Pair

SAFETY SPECS PROMAX 'BLZ'

- Protects like a goggle
- Light Weight
- Extremely Comfortable



Part No.	Description	Unit
7-BZC	Clear - With Bonus Strap & Pouch	Pair
7-BZS	Smoke - With Bonus Strap & Pouch	Pair
7-BZA	Amber (Indoor / Light Enhancing) - With Bonus Strap & Pouch	Pair



WELDING CURTAINS

- Designed to protect workers from indirect welding flash
- Allows natural light into work areas
- Zip-Ties and Curtain Rings Supplied with Each Curtain - Ready to Install
- Long-Life Construction: Double Hem, Stitched with Heat-Resistant Kevlar Thread, with Heavy Duty Brass Eyelets
- Available in Red or Green
- Fire retardant
- Tested & Conforms to DIN EN 1598: 2011-12 (European standard)

Comes with Free rings & ties!



INDICATIVE PRICE
7-1818R/G

\$79⁰⁰
Excl GST*

For your nearest Distributor
Phone 1300 784 200

*Prices are indicative only and may vary depending on volumes, freight cost, models/options & other factors

Part No.	Description	Unit
7-1813G	1.8 x 1.3m Green	Each
7-1813R	1.8 x 1.3m Red	Each
7-1818G	1.8 x 1.8m Green	Each
7-1818R	1.8 x 1.8m Red	Each
7-1820G	1.8 x 2.0m Green	Each
7-1820R	1.8 x 2.0m Red	Each
7-1827G	1.8 x 2.7m Green	Each
7-1827R	1.8 x 2.7m Red	Each
7-1834G	1.8 x 3.4m Green	Each
7-1834R	1.8 x 3.4m Red	Each
7-1855G	1.8 x 5.5m Green	Each



WELDING CURTAIN FRAME & KITS HEAVY-DUTY 1.8 X 2.0M

- Heavy-Duty Coated RHS Frame with Welded Corner Brackets
- Includes Lockable Castor Wheels
- Two or More Frames Can be Joined Together (bolts and nuts/washers included), to Create Longer Screens.
- Frame only - does not include curtain
- Suits 1.8 x 2.0m curtains

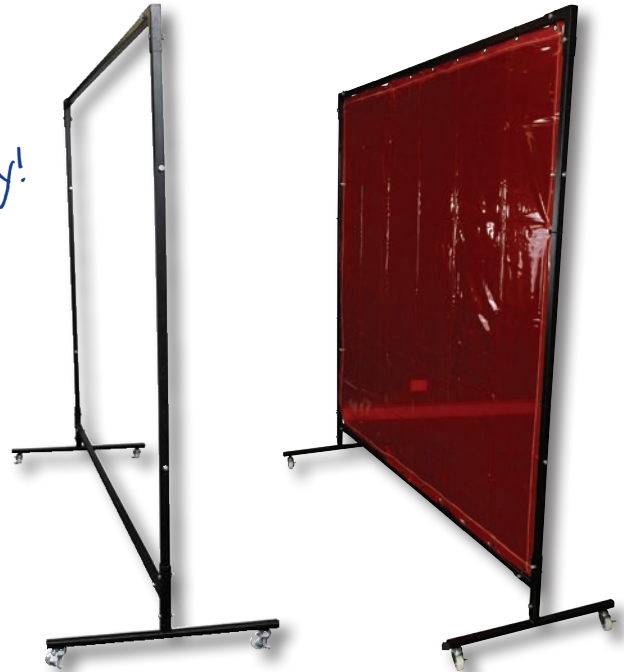
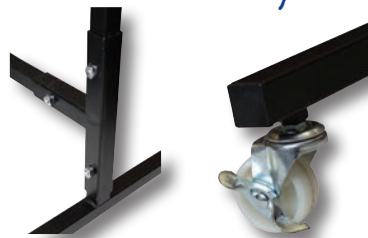
Heavy-Duty!

INDICATIVE PRICE
7-WCF1820 Frame Only

\$199⁰⁰
Excl GST*

For your nearest Distributor
Phone 1300 784 200

*Prices are indicative only and may vary depending on volumes, freight cost, models/options & other factors



Part No.	Description	Unit
WC-04012	H/Duty - Suit 1.8 x 2.0m Curtain [Frame Only]	Each
WC-03235K	Frame & Curtain Combo Kit 1.8 x 2.0m Red	Kit
WC-03236K	Frame & Curtain Combo Kit 1.8 x 2.0m Green	Kit

WELDING CURTAIN FRAMES & KITS STANDARD 1.8 X 1.8M

- Coated Steel Frame
- Spring Pin Joints for Fast Assembly
- Includes Castor Wheels
- Supplied in flat pack kit form - Just snap together
- Frame only - does not include curtain
- Suits 1.8 x 1.8m curtains

Great Value!

INDICATIVE PRICE
WC-04349 Frame Only

\$129⁰⁰
Excl GST*

For your nearest Distributor
Phone 1300 784 200

*Prices are indicative only and may vary depending on volumes, freight cost, models/options & other factors



Part No.	Description	Unit
WC-04349	Suit 1.8 x 1.8m Curtain [Frame Only]	Each
WC-03238K	Frame & Curtain Combo Kit 1.8 x 1.8m Red	Kit
WC-03239K	Frame & Curtain Combo Kit 1.8 x 1.8m Green	Kit



EARPLUGS 'PROMAX EP5' DISPOSABLE

- Popular taper fit, soft foam style earplugs for general use
- Tested and conform to AS/NZS1270:2002 for Class 5 protection
- Each pair is hygienically packed in clear plastic bag



Part No.	Description	Unit
WC-05377	Un-Corded	Box 200pr
WC-05378	Un-Corded	Pkt 500pr

EARMUFF YELLOW 24DB

- Class 4 ear protection - 24 dB SLC80 Rating
- Tested and conform to AS/NZS1270:2002
- Durable and light weight



Part No.	Description	Unit
P7-EMC4	Earmuff 24dB	Pair

EARMUFF RED 30DB

- Folding style earmuff with padded comfort headband
- Durable and light weight
- 30dB ear protection



Part No.	Description	Unit
P7-EM30	Earmuff 30dB	Pair



DISPOSABLE RESPIRATORS PROMAX P2 SERIES

- Australian standards certified to AS/NZS 1716
- P2 Class Filtering, for dust, mists & fumes
- Model P2VC is premium welding respirator with Carbon Filter to remove annoying odours
- Electro-statically attracts & traps fine particles into the filter (much more effective than mechanical filtration)



P2VF



P2V



P2VC

Part No.	Description	Unit
7-RMX06	With Valve - Cupped PROMAX P2V	Box 10
7-RMX08	With Valve - Fold Flat PROMAX P2VF	Box 10
7-RMX10	With Valve & Carbon Filter - Cupped PROMAX P2VC	Box 10

STUDENT SAFETY KIT

- Ideal for students and apprentices
- Includes: Flip front welding helmet, oxy goggles, clear safety specs, earmuffs & welding gloves
- Supplied with carry/storage bag



Part No.	Description	Unit
7-TSSK/CBK	Safety Kit	Kit



GLOVES, APPAREL & BLANKETS

A quick look at...



WELDER'S JACKETS

- Made with attention to detail & using only the best quality materials
- Designed for comfort and long Service life
- Quality you can feel



See page 133-137



RIGGER GLOVES PROMAX KR

- Premium A-Grade Cowgrain Leather
- Consistent Quality: Each Batch Produced & Checked According to Weldclass Strict Specifications

Kevlar sewn for long life!



Part No.	Description	Unit
8-WRM	M	Pair
8-WRL	L	Pair
8-WRXL	XL	Pair
8-WR2XL	2XL	Pair

WELDING GLOVES PROMAX BLUE

- Crafted for Excellent Fit: Try a pair to experience the difference!
- Top Quality: Premium cowhide leather, Reinforced, Sewn with Heat-Resistant Kevlar thread
- Available in Left-Hand only, for use where only lefts are used, or where lefts wear at a faster rate than rights
- Fully Lined

Super comfortable & super tough!



Part No.	Description	Unit
WC-01775	400mm - Standard Pairs	Pair
WC-01777	400mm - Left-Hand (1 pr = 2 Left-Hand Gloves)	Pair



WELDING GLOVES PROMAX BLUE XC

- Xtended Cuff: Provides Full Arm Protection - total glove length 680mm
- Top Quality: Premium cowhide leather, Reinforced palm, Sewn with Heat-Resistant Kevlar thread
- In hot environments where excess clothing can be a health risk, Platinum XC gloves are sometimes used in place of a full jacket, as they offer full arm protection
- Available in Left-Hand only, for use where only lefts are used, or where lefts wear at a faster rate than rights



680mm for full arm protection!



Part No.	Description	Unit
WC-01774	Xtended-Cuff 680mm - Standard	Pair
WC-01778	Xtended-Cuff 680mm - Left-Hand (1 pr = 2 Left-Hand)	Pair

TIG WELDING GLOVES PLATINUM TG-21

- Top selling TIG Glove: Try a pair to experience the difference!
- Specially Selected Leather and Carefully Crafted for Maximum Comfort and Sensitivity
- The Best of Both: Excellent Dexterity / Feel - AND - Good Heat-Resistance / Long Life
- Sewn with Heat-Resistant Kevlar Thread = Resistant to Seam Failure



Attn: TIG welders you must try these!



Part No.	Description	Unit
WC-04676	Platinum TIG Glove 360mm	Pair





GLOVE SAVERS PROMAX

- Reduces "Hot Hand" - Aluminized / Reflective Kevlar back reflects heat away from welding glove
- Increases Glove Life, Provides Extra Protection of Palm, Upper & Thumb
- Slip Over any Welding Glove
- Sewn with Heat-Resistant Kevlar thread
- Available in RH only or LH only



Part No.	Description	Unit
8-LGS	Left Hand - Leather with Aluminised Top	Each
8-RGS	Right Hand - Leather with Aluminised Top	Each

LEATHER SPATTS HOOK & LOOP CLOSURE

- Leather spatts protect your boots and feet from spatter
- Premium cowsplit leather
- Sewn with Kevlar thread
- Long series with Hook & Loop closure
- Height 340mm
- Side stiffeners
- Suitable for general purpose heat, flame and spark protection.



Part No.	Description	Unit
8-LSPV	Height 340mm	Pair

LEATHER SPATTS BUCKLE STYLE CLOSURE

- Leather spatts protect your boots and feet from spatter
- Premium cowsplit leather
- Sewn with Kevlar thread
- Leather straps with buckle closure
- Side stiffeners
- Height 310mm
- Suitable for general purpose heat, flame and spark protection.



Part No.	Description	Unit
8-LSPB	Height 310mm	Pair



FR HOODS PROMAX (PROBAN STYLE)

- Lightweight and Cool Flame-Resistant Cotton
- Hook & Loop Opening Chin to Chest - Allows Wearer to Remove Hood Without Pulling Over The Head - Prevents Dust & Debris Falling Onto the Head, Face & Eyes
- Sewn with Kevlar Heat-Resistant Thread to Prevent Seam Failure, much more durable than standard cotton seams
- Draw-string Face Closure for Close-Fitting Seal against Sparks & Spatter
- 100% Cotton Specially Treated for Flame-Resistance: Durable and More Comfortable than Cotton/Polyester Material
- Good Coverage of Head, Neck and Throat

INDICATIVE PRICE
\$29⁸⁰ Excl GST*
 For your nearest Distributor
 Phone 1300 784 200
*Prices are indicative only and may vary depending on volumes, freight cost, models/options & other factors



Part No.	Description	Unit
WC-01795	PROMAX Blue	Each
WC-03772	PROMAX HV - Hi-Viz Orange	Each

The products advertised above are original Weldclass products only. Any references to the trade name Proban is for identification purposes only. Weldclass is not affiliated in any way with the owner(s) of the trade name Proban and the products are not original Proban.

FR HOOD FOR WELDING HELMET PROMAX BLUE (PROBAN STYLE)

- Blocks out annoying sunlight & reflections from behind the helmet
- Protects head, neck and ears from spatter, debris, sun-burn, etc
- Fast and easy to fit to your welding helmet - Supplied with self-stick hook & loop
- Great for site and field welders, overhead welding, etc
- For Protection During Welding, Cutting & Grinding
- Stop painful burns from spatter entering neck, collar, ears etc
- Improves vision and weld quality by blocking out light and reflection
- Open design allows good ventilation
- Lightweight and Cool flame-retardant cotton
- Sewn with Kevlar Heat-Resistant Thread to Prevent Seam Failure



Part No.	Description	Unit
WC-05456	PROMAX Blue Helmet Hood	Each

The products advertised above are original Weldclass products only. Any references to the trade name Proban is for identification purposes only. Weldclass is not affiliated in any way with the owner(s) of the trade name Proban and the products are not original Proban.



LEATHER APRON PROMAX BLUE

- 'Promax Blue' Premium Leather;
- Top Quality Split Cowhide Sourced from America & Italy
- Resists Ageing/Hardening, Remains Supple and Tough for longer
- Does not shed fibres like standard grey/chrome leather
- Riveted Stress Points & Double-Stitched with Kevlar = Longer Garment Life In Tough Conditions
- Utility Pocket for Tools, Rulers, Markers etc



Part No.	Description	Unit
WC-01753 (8-LAX01)	PROMAX Blue Leather Apron 900 x 600mm	Each

LEATHER JACKETS PROMAX BLUE

- 'Premium Blue' Leather;
- Top Quality Split Cowhide
- Does not shed fibres like standard grey/chrome leather
- Adjustable Cuffs and Collar
- Front Pocket
- Double Sticked with Kevlar Heat-Resistant Thread with Rivets at pressure points
- For Protection During Welding, Cutting & Grinding
- With Pen pocket & front internal pocket

INDICATIVE PRICE

\$9900

Excl GST*

For your nearest Distributor
Phone 1300 784 200

*Prices are indicative only and may vary depending on volumes, freight cost, models/options & other factors



Part No.	Description	Unit
WC-01782	M	Each
WC-01781	L	Each
WC-01783	XL	Each
WC-01784	2XL	Each
WC-01785	3XL	Each



FR JACKETS
PROMAX BLUE (PROBAN STYLE) W/ LEATHER SLEEVES

*Australia wide
Best Seller!*

Part No.	Description	Unit
WC-04653	M	Each
WC-04658	L	Each
WC-04655	XL	Each
WC-04656	2XL	Each
WC-04657	3XL	Each

The products advertised above are original Weldclass products only. Any references to the trade name Proban is for identification purposes only. Weldclass is not affiliated in any way with the owner(s) of the trade name Proban and the products are not original Proban.

Stand-Up Collar
With adjustable Flap for Full Closure & Protection

Satin-Lined Shoulders
For easier Wear / Removal

Promax Blue Fire Retardant Cotton
Lighter & Cooler than Leather

Adjustable Cuffs
With Reinforced Press Studs

Leather Sleeves
For Heavy Duty Spatter Protection



Top Quality Cowhide Leather
Remains Supple & Durable for longer

Double-Stitched with Kelvar
Rivets at Stress Points

Large Front Pockets
With Flap & Velcro Style Closure

Pen / Scribe Pockets
On both Sleeves

Wide Hook & Loop Strip
For firm closure (no studs to tear off)



SIZE INFO:

- Approx' Chest Measurement in cm:
M=121 / L=127 / XL=137 / 2XL=147 / 3XL=157

INDICATIVE PRICE

\$9900
Excl GST*

For your nearest Distributor
Phone 1300 784 200

*Prices are indicative only and may vary depending on volumes, freight cost, models/options & other factors



FR JACKETS
PROMAX BLUE FLAME (PROBAN STYLE)

Cool, comfortable, quality construction & Great Value!

Part No.	Description	Unit
WC-01797	M	Each
WC-01798	L	Each
WC-01799	XL	Each
WC-01800	2XL	Each

The products advertised above are original Weldclass products only. Any references to the trade name Proban is for identification purposes only. Weldclass is not affiliated in any way with the owner(s) of the trade name Proban and the products are not original proban.

Light & Cool Flame-Retardant Cotton
 For light to medium protection against grinding sparks, welding spatter and protection during Welding, Cutting & Grinding
 Not recommended for applications where protection from heavy spatter is required

Stand-Up Collar
 With adjustable flap for Full Closure & Protection

Flame-Retardant Stitching

Wide Hook & Loop Strip
 For firm closure (no studs to tear off)

Adjustable Cuffs & waist straps
 (with reinforced studs)

Internal Pockets

Pen / Scribe Pocket
 Handy Spot for Markers, Scribes, Small Rules, etc

Eye-Catching Flame Graphics



INDICATIVE PRICE
\$69⁹⁰ Excl GST*

For your nearest Distributor
 Phone 1300 784 200

*Prices are indicative only and may vary depending on volumes, freight cost, models/options & other factors

SIZE INFO:

- Approx' Chest Measurement in cm:
 M=121 / L=127 / XL=137 / 2XL=147 / 3XL=157



FR JACKETS

PROMAX 'HV2' W/LEATHER SLEEVES + HARNESS FLAP

The ultimate welding AND Safety Jacket!

Crafted with Attention to Detail:

- Double-Stitched with Kevlar and reinforced with rivets at pressure-points for longer garment life
- Large internal pocket, pen/ruler pockets
- Satin-lined shoulders for easier wear & removal
- Double Stitched with Kevlar Thread, with Rivets at pressure points (e.g. cuffs) to prevent seam failure
- 100% Cotton FR Material: More Durable & more Comfortable than Cotton/Polyester Fabrics

Part No.	Description	Unit
WC-04762	M	Each
WC-04763	L	Each
WC-04764	XL	Each
WC-04765	2XL	Each
WC-04766	3XL	Each
WC-04767	4XL	Each

The products advertised above are original Weldclass products only. Any references to the trade name Proban is for identification purposes only. Weldclass is not affiliated in any way with the owner(s) of the trade name Proban and the products are not original Proban.

Leather Sleeves

Made from top-quality cowhide, for long-lasting spatter protection



INDICATIVE PRICE

\$139⁰⁰ Excl GST*

For your nearest Distributor
Phone 1300 784 200

*Prices are indicative only and may vary depending on volumes, freight cost, models/options & other factors

Extended Back

Protects Lower Back when Bending, Kneeling, etc

Harness Compatible

Rear Opening/Flap Allows use with Safety Harness, if required

Now with 'X' Pattern

Reflective on Back

Suitable for Rail Industry use



100% Flame Resistant
including Silver Reflective Tap

Hi-Visibility
Material with Reflective Tape for Day/Night use

SIZE INFO:

- Approx' Chest Measurement in cm:
M=121 / L=127 / XL=137 / 2XL=147 / 3XL=157 / 4XL=167



FR JACKETS PROMAX 'HV5'

Cool, comfortable & incredibly cost effective!

Part No.	Description	Unit
WC-05261	M	Each
WC-05262	L	Each
WC-05263	XL	Each
WC-05264	2XL	Each

The products advertised above are original Weldclass products only. Any references to the trade name Proban is for identification purposes only. Weldclass is not affiliated in any way with the owner(s) of the trade name Proban and the products are not original Proban.

Light & Cool Flame-Retardant Cotton
for medium duty, affordable Protection

Stand-Up Collar
With adjustable flap for Full Closure & Protection

Flame-Retardant Stitching

Wide Hook & Loop Strip
For firm closure (no studs to tear off)

High-Vis Orange
Welders deserve Hi-Vis Protection too!

Pen / Scribe Pocket



INDICATIVE PRICE
\$45⁰⁰
Excl GST*

For your nearest Distributor
Phone 1300 784 200

*Prices are indicative only and may vary depending on volumes, freight cost, models/options & other factors

Internal Pocket



SIZE INFO:

- Approx' Chest Measurement in cm:
M=121 / L=127 / XL=137 / 2XL=147



BLANKETS PROMAX LEATHER

- Heavy Duty Split Cowhide Leather
- Sewn with Heat-Resistant Kevlar Thread, for resistance to seam failure
- For protection against grinding sparks, light to medium spatter, indirect heat

with eyelets!



Part No.	Description	Unit
WC-01755	1.0m x 2.0m	Each
WC-03834	1.8m x 1.8m	Each
WC-01756	2.0m x 2.0m	Each
WC-01757	3.0m x 3.0m	Each



HI-TEMP BLANKET 550°C

- Tightly woven glass fabric
- 550°C working temperature (continuous exposure resistance)
- Smooth, non hairy low-irritant finish
- For protection against grinding sparks, light to medium spatter, intermittent low flame, etc
- Suitable for wrapping components that require slow cooling, heat treating and stress relief applications
- NOT recommended for protection against heavy slag or molten droplets

USER INFO:

- Always use on an incline of at least 15 degrees, when using for surface protection
- If protecting critical or costly surfaces/items, always use more layers initially, and test on a non-critical surface first



Part No.	Description	Unit
8-WB550/1018	Blanket 1.0m x 1.8m	Each
8-WB550/1820	Blanket 1.8m x 2.0m	Each
8-WB550/2030	Blanket 2.0m x 3.0m	Each
8-WB550/3030	Blanket 3.0m x 3.0m	Each
8-WB550/10RL	Roll 50m x 1.0m	Roll
8-WB550/15RL	Roll 50m x 1.5m	Roll

HI-TEMP BLANKET 1100°C

- Tightly woven glass fabric
- 1100°C working temperature (continuous exposure resistance)
- Smooth low-irritant finish
- For molten metal splash protection - eg: oxy cutting, gouging, heavy spatter, intermittent flame, etc
- Suitable for retaining wrapping components that require slow cooling / heat-treating

USER INFO:

- If protecting critical or costly surfaces/items, always use more layers initially, and test on a non-critical surface first
- When using for surface protection: If possible use on an incline of at least 15 degrees, or when necessary to use in horizontal position add more layers



Part No.	Description	Unit
8-WBSG11/0918	Blanket 1.8 x 0.9m	Each
8-WBSG11/1820	Blanket 1.8 x 2.0m	Each
8-WBSG11/2030	Blanket 2.0 x 3.0m	Each
8-WBSG11/3030	Blanket 3.0 x 3.0m	Each
8-WBSG11/09RL	Roll 50 x 0.9m	Roll



CABLE COVERS SUIT TORCH CABLES

- Extends the Life of Torch Cables = Reduced Replacement / Repair Costs & Down-Time
- Velcro Style Fastening for Quick Fitting
- Premium Blue Heavy Duty Cowhide Leather, and Heat-Resistant Kevlar Thread
- Can be cut to length if required
- Ideal For MIG, TIG & Plasma Torch Cables
- Also suits all types of cables and hoses
- Protects against: hot metal burns, sparks and spatter and general wear and tear



Part No.	Description	Unit
8-CC4	4m x 150mm - Suit 3-4m MIG/TIG Torches	Each
8-CC7	7.5m x 150mm - Suit 7-8m TIG/Plasma Torches	Each

CABLE COVERS SUIT WIRE-FEED CABLES

- Extends the Life of Torch Cables = Reduced Replacement / Repair Costs & Down-Time
- Velcro Style Fastening for Quick Fitting
- Premium Blue Heavy Duty Cowhide Leather, and Heat-Resistant Kevlar Thread
- Can be cut to length if required
- Ideal for MIG Welder Wire-Feeder cables
- Also suits all types of cables and hoses
- Protects against: hot metal burns, sparks and spatter and general wear and tear



Part No.	Description	Unit
8-CC8	8m x 200mm - Suit 8m Wire-Feeder Cables	Each
8-CC10	10m x 200mm - Suit 10m Wire-Feeder Cables	Each

FR & LEATHER SLEEVES PROMAX BLUE

- Elasticised ends for easy fitting
- No ties or straps
- Combination Leather & FR Cotton: Durable, yet light weight and cool



Part No.	Description	Unit
WC-05375	Sleeves Promax Blue Leather/FR	Each



Trading Terms & Conditions



Weldclass' Standard Trading Terms & Conditions can be viewed at:
www.weldclass.com.au/StandardTradingTermsAndConditions





9 341562 030007

Part No. WC-03000



www.weldclass.com.au

Ph: 1300 784 200

E: marketing@weldclass.com.au

Your Weldclass Distributor:

