





# Grinding and cut-off wheels

## Table of contents



Contents	Page
■ General information	3
■ The fast way to the best tool	4
■ Technical information	6

Tool drive	Contents	Page
<b>Grinding</b>		
	<b>Reinforced grinding wheels</b> 7 <ul style="list-style-type: none"> <li>■ Universal Line PS-FORTE</li> <li>■ Performance Line SG-ELASTIC</li> <li>■ Special Line SG-PLUS</li> <li>■ Foundry reinforced grinding wheels</li> <li>■ Pipeline reinforced grinding wheels</li> </ul>	
	<b>CC-GRIND® grinding discs</b> 22 <ul style="list-style-type: none"> <li>■ Performance Line SG</li> </ul>	
	<b>Cup wheels</b> 27 <ul style="list-style-type: none"> <li>■ Performance Line SG-ELASTIC</li> </ul>	
	<b>Ring wheels</b> 28 <ul style="list-style-type: none"> <li>■ Performance Line SG-ELASTIC</li> </ul>	
	<b>Arbors</b> 28	
	<b>POLIFAN® flap discs</b> 29 <ul style="list-style-type: none"> <li>■ Universal Line PSF</li> <li>■ Performance Line SG</li> <li>■ Special Line SGP</li> </ul>	

	Angle grinders
	Angle grinders with cup wheel covering hood
	Straight grinders

PFERD offers premium-quality grinding and cut-off wheels. Years of practical experience contribute to the development of new innovative products.

Tool drive	Contents	Page
<b>Cutting</b>		
	<b>Cut-off wheels for manual applications</b> 44 <ul style="list-style-type: none"> <li>■ Universal Line PS-FORTE</li> <li>■ Performance Line SG-ELASTIC</li> <li>■ Special Line SG-PLUS</li> <li>■ Foundry cut-off wheels</li> </ul>	
	<b>Clamping flange set</b> 48	
	<b>Small cut-off wheels dia. 30–76 mm</b> 56 <ul style="list-style-type: none"> <li>■ Performance Line SG-ELASTIC</li> </ul>	
	<b>Arbors</b> 57	
	<b>Cut-off wheels for hand-held cut-off machines with petrol or electric motors dia. 300–400 mm</b> 58 <ul style="list-style-type: none"> <li>■ Performance Line SG-ELASTIC</li> </ul>	
	<b>Diamond cut-off wheels</b> 64 <ul style="list-style-type: none"> <li>■ Universal Line PSF</li> <li>■ Performance Line SG</li> </ul>	

 For detailed information and ordering data for stationary cut-off wheels, please refer to Catalogue 207.

	Hand-held cut-off machines with a petrol motor for cut-off wheels dia. 300–400 mm
	Hand-held cut-off machines with an electric motor for cut-off wheels dia. 300–400 mm



Reinforced grinding wheels



POLIFAN® flap discs



Cut-off wheels



Diamond cut-off wheels



### PFERD quality

PFERD grinding and cut-off wheels are developed, manufactured and tested to the highest quality standards. The standard-compliant dimensional stability indicates the comprehensive PFERD quality.

In addition to the high quality standards, health and safety as well as ergonomics play a prominent role.

PFERD quality management is certified according to ISO 9001.



### PFERD support and training

PFERD offers you individual targeted support to solve your application problems. PFERD's experienced sales representatives and technical advisors will be pleased to assist you. Please contact us.

In the **PFERDAKADEMIE**, we provide highly specialized and practical knowledge from the world of grinding and cutting. Through the successively built-up blocks of seminars, you will become a PFERD tool specialist.

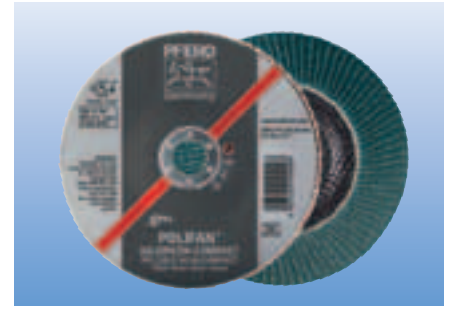

### Products made to order

If you cannot find the solution for your particular application in our product range, we can produce grinding and cut-off wheels in premium PFERD quality on request, tailor-made to meet the requirements of your job.

Taking into account the material to be worked and the given application, we offer individual and effective advice with the aim of finding the best and most economical solution for you.

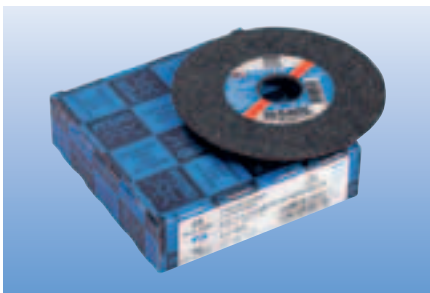

### PFERD packaging

PFERD supplies grinding and cut-off wheels in sturdy industrial packaging that protects the tools from damage. For packaging units, please refer to the product tables. Important information, such as article number, description, EAN code and technical information can be found on the packaging labels.



### PFERD TOOL-CENTER

On the PFERD TOOL-CENTER of your local retailer, you will find all the important information required for selecting the most appropriate tool. The PFERD information and symbol cards provide important tips about tools and applications.

If you have any questions, your local retailer or PFERD sales representative will be happy to help you.

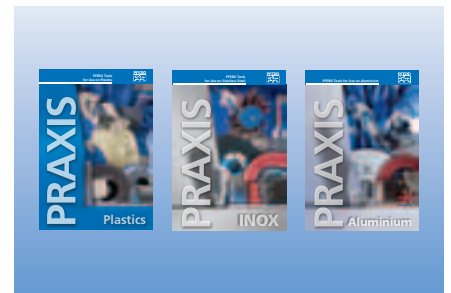

### PFERD PRAXIS

PFERD PRAXIS brochures contain much valuable information on material properties, as well as tips and tricks on the use of PFERD tools.



### PFERDVIDEO

You will receive more information here or at [www.pferd.com](http://www.pferd.com)

### PFERDERGONOMICS®

The **PFERDERGONOMICS®** programme aims at the long-term reduction of dust, noise and vibration levels produced by tools, and on perceptibly increasing tool haptics. The focus is on people.

Recognize straight away the areas where our tools offer you advantages.

Tools with **PFERDERGONOMICS®** properties are marked with corresponding pictograms.



For more information and appropriate PFERD tools, see the brochure "**PFERDERGONOMICS®** – The focus is on people".

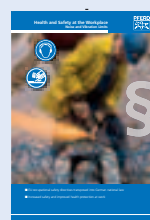

PFERD grinding and cut-off wheels help reduce hazardous vibration and noise of the working process. The requirements of ISO 6103 are met.

For more information, see the brochure "Health and safety at the workplace – noise and vibration limits".

# Grinding and cut-off wheels

The fast way to the best tool



## How to find the best tool

Selecting the most efficient tool is a prerequisite for the highest economic value and best results.

To help you choose the appropriate tool, we consider the application ①, the material to be worked ② and the available tool drive ③.

The following explanations will help you select the best tool.

## ① Application

① Application	Tools	Reinforced grinding wheels	Foundry reinforced grinding wheels	Pipeline reinforced grinding wheels	CC-GRINDING discs
Grinding					
Surface grinding		Page 8	Page 16	–	Page 2
Weld dressing		Page 8	–	–	Page 7

Starting from the application, you can select the optimum tool solution from the extensive PFERD product range. Please use the **overview on the opposite page**.

You can find further information on the catalogue page indicated.

Selection: Surface grinding, reinforced grinding wheels – Page 8

## ② Material

① Application	② Material		Stainless steel (INOX)		Aluminium/non-ferrous metals	
	Type	Page	Type	Page	Type	Page
Surface grinding	PS-FORTE	10	PS-FORTE	11	SG-ELASTIC	14
	Hardness K	10, 12	Hardness M	11		
	Hardness P	11	Hardness L	12	Hardness N (ALU)	21
	Hardness L	11	Hardness P	12	Hardness H	21
	SG-ELASTIC	13, 18	SG-ELASTIC	14		
	Hardness R	20	Härte N (INOX)	20		
	Hardness H	20	Hardness H	20		

After the application, you can choose the **material to be worked** from the spectrum of materials. Then select the optimum tool for your requirements from the **versions** available.

For better identification, the various materials are **colour coded** and are also found **on the tool labels**.

An **overview of the different material groups** is given on the next page.

Selection: Stainless steel (INOX), SG-ELASTIC, Hardness N (INOX) – Page 14

## ③ Tool drive



**Materials to be worked:**  
Stainless steel (INOX)

**Application:**  
Surface grinding, work on weld seams, chamfering, deburring, fillet weld grinding, grouting

**Recommendations for use:**  
■ Achieves best grinding results on high-powered angle grinders

After successful tool selection, please refer to the respective catalogue page for **recommendations on the ideal tool drive**.

There, we have taken into account the **drive power output (watts)** of commercially available tool drives.

Please also refer to the **overview on the opposite page**.

Selection: High-powered angle grinders



Application	Tools	Reinforced grinding wheels	Foundry reinforced grinding wheels	Pipeline reinforced grinding wheels	CC-GRIND® grinding discs	Cup wheels	Ring wheels	POLIFAN® flap discs
<b>Grinding</b>								
Surface grinding		Page 8	Page 16	–	Page 22	–	–	Page 30
Work on weld seams		Page 8	–	–	Page 22	–	–	Page 30
Chamfering		Page 8	–	–	Page 22	Page 27	–	Page 30
Deburring		Page 8	Page 16	–	Page 22	Page 27	–	Page 30
Grouting		–	–	Page 18	–	–	Page 28	–
Fillet weld grinding		Page 8	–	–	–	–	–	Page 30

Application	Tools	Cut-off wheels	Foundry cut-off wheels	Diamond cut-off wheels
<b>Cutting</b>				
Cutting of sheet metal and thin-walled profiles < 3 mm		Page 46	–	–
Cutting of solid material and profiles		Page 46	Page 62	Page 65

Overview of materials/material groups		
Steel, cast steel	Non-hardened, non-heat-treated steels up to 1,200 N/mm² (< 38 HRC)	Construction steels, carbon steels, tool steels, non-alloyed steels, case-hardened steels, cast steel
	Hardened, heat-treated steels over 1,200 N/mm² (> 38 HRC)	Tool steels, tempering steels, alloyed steels, cast steel
Stainless steel (INOX)	Rust- and acid-resistant steels	Austenitic and ferritic stainless steels
Aluminium	Aluminium alloys, soft	Non-hardening and hardening wrought alloys, soft condition
	Aluminium alloys, toughened	Cast aluminium alloys with low silicon content
	Aluminium alloys, hard	Cast aluminium alloys without silicon
Non-ferrous metals	Non-ferrous metals, soft	Brass, copper, zinc
	Non-ferrous metals, hard	Bronze
Cast iron	Grey cast iron	Cast iron with flake graphite EN-GJL (GG), with nodular graphite/nodular cast iron EN-GJS (GGG)
	White cast iron	White annealed cast iron EN-GJMW (GTW), black cast iron EN-GJMB (GTS)
Stone	Soft, abrasive	Cotto, pumice, light concrete, sandstone
	Medium-hard	Concrete, concrete blocks, roofing tiles
	Hard	Reinforced concrete, granite, clinker, exposed concrete, tiles, ceramic tiles, slate
Plastics, other materials	–	Fibre-reinforced plastics (GRP/CRP), thermoplastics

Overview of tool drives								
Output categories	Drive type	Wheel/disc diameter [mm]	100/105	115	125	150	178/180	230
		Power output	Watts	Watts	Watts	Watts	Watts	Watts
Speed-stable (compressed air/turbine high frequency)	Compressed air, regulated		–	< 1,000	< 2,300	< 2,300	< 4,500	< 4,500
	High frequency (300 Hz)		–	–	< 1,700	–	< 3,700	< 3,700
High power	Compressed air		< 800	< 900	< 1,100	–	< 1,900	< 2,200
	Electric, regulated, mains power supply		–	< 1,750	< 1,750	–	< 2,500	< 2,800
	Electric, mains power supply		< 700	< 1,000	< 1,200	< 1,750	< 2,200	< 2,500
	Electric, battery power supply		≥ 500	≥ 500	≥ 500	–	–	–
Low power	Compressed air		< 400	< 600	< 800	–	< 1,500	< 1,800
	Electric, mains power supply		< 500	< 700	< 900	< 1,750	< 1,800	< 2,000
	Electric, battery power supply		≥ 300	≥ 300	≥ 300	–	–	–

If the tool drives power output is not known, we recommend to consider the "low power" values as a guideline.

# Grinding and cut-off wheels

## Technical information

### Maximum operating speed

The maximum operating speed [m/s] is indicated by a colour bar on the product labels and product packaging, in accordance with the specifications of EN 12413, EN 13743 and EN 13236. The maximum permissible rotational speed specification applies to the nominal diameter of the unused grinding tools.

Maximum operating speed	Colour bar
50 m/s	blue
63 m/s	yellow
80 m/s	red
100 m/s	green

### Safety standards

Grinding and cut-off wheels made by PFERD conform to the most exacting safety requirements and are marked according to the following key European and international safety standards:

- EN 12413 for grinding tools with bonded abrasives
- EN 13236 for grinding tools with diamond or boron nitrate
- EN 13743 for abrasives on backing material
- ANSI B7.1 / OSHA regulations
- AS 1788.2

### Grinding safety

Abrasive manufacturers, machine producers and users all contribute to grinding safety.

All PFERD tools are built to meet the prescribed safety codes. The user, however, is responsible for proper handling of the tool drive and correct use and application of the grinding tool.

Do you have any questions on grinding safety? PFERD will be glad to provide advice and support, whether through seminars at our PFERDAKADEMIE or on-site via our sales representative.

### PFERD is a long-standing member of oSa

Together with other manufacturers, PFERD has voluntarily undertaken to produce quality tools conforming to the most exacting safety standards.

Member companies of oSa (The Organization for the Safety of Grinding Tools) are committed to continuous product safety and quality monitoring. PFERD tools carry the oSa mark.



### Dimensions

The following abbreviations are used in drawings and tables: D (= Outer dia.), T or U (= Width), H (= Centre hole), W (= Wall thickness) and J (= Smallest dia.).

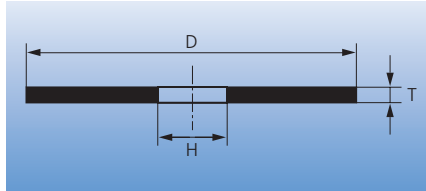

Flat type

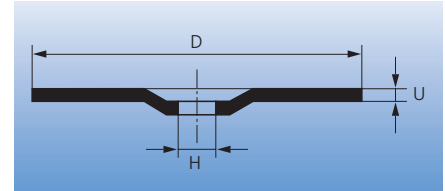

Depressed-centre type

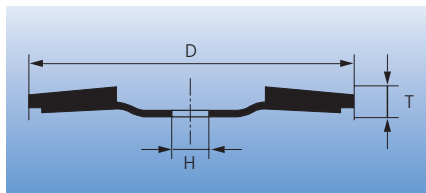

Conical type

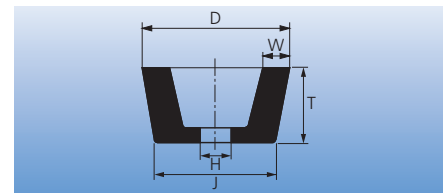

Cup wheel, tapered type

### Safety notes



= Wear eye protection!



= Wear gloves!



= Wear hearing protection!



= Read the safety instructions!



= Wear a respirator!



= Observe the minimum blade angle on reinforced grinding wheels!



= Not permitted for circumferential grinding!



= Do not use if damaged!

### Mounting system

The safe use of PFERD tools is highly dependent on the mounting system.

Both flanges clamping a grinding tool must always have matching support diameters (according to EN 60745-2-3, EN 60745-2-22, ISO 11148-7, ANSI B7.1, AS 1788.1).

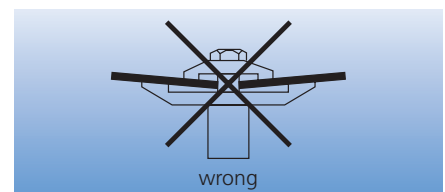
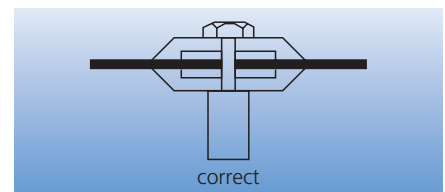

### Adapter for reinforced grinding wheels

In some countries, specific requirements apply with regard to the use of special flange or adapter systems on 178 and 230 mm dia. reinforced grinding wheels.

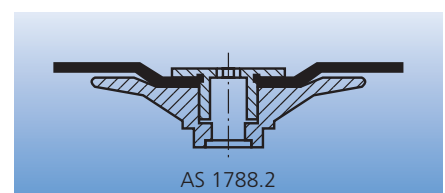





# Reinforced grinding wheels

The fast way to the best tool

PFERD reinforced grinding wheels meet today's requirements with regard to outstanding stock removal, handling convenience, and high cost-efficiency.

PFERDERGONOMICS® recommends the reinforced grinding wheels WHISPER, along with CC-GRIND® and CC-GRIND®-SOLID grinding discs as innovative tooling solutions.

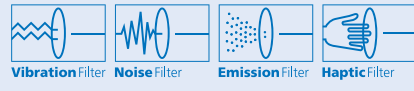

## Product lines

For the many different grinding tasks in industry and crafts, PFERD offers reinforced grinding wheels in three product lines with diverse special features:

Universal Line PS-FORTE (PSF)	Performance Line SG-ELASTIC (SG)	Special Line SG-PLUS (SGP)
 <p>For general use in industry and crafts</p>	 <p>Widest range of tools for professional use in industry and crafts</p>	 <p>For special tasks in the industry</p>

## The fast way to the best tool

Starting with the application ① and material ②, the overview shows the various types of tools in the PFERD range and helps you to find the best tool. For information on tool drives, please refer to the respective catalogue page.

① Application	② Material Steel		Stainless steel (INOX)		Aluminium/ non-ferrous metals		Casting scale/ cast iron		Cast iron/ stone	
	Type	Page	Type	Page	Type	Page	Type	Page	Type	Page
Surface grinding	PS-FORTE		PS-FORTE		SG-ELASTIC Hardness N (ALU) 14 SG-PLUS Hardness H 21	SG-ELASTIC Hardness S (AC-CAST) 16 Hardness S (ZA-CAST) 17 SG-PLUS Hardness T 17	SG-ELASTIC Hardness Q 16			
	Hardness K	10	Hardness M	11						
	Hardness P	10, 12	Hardness L	11						
	Hardness L	11	Hardness P	12						
	SG-ELASTIC		SG-ELASTIC							
Hardness R	13, 18	Hardness N (INOX)	14							
SG-PLUS		SG-PLUS								
Hardness H	20	Hardness H	20							
CC-GRIND®	22	CC-GRIND®	22							
CC-GRIND®-SOLID	24	CC-GRIND®-SOLID	24							
Work on weld seams	PS-FORTE		PS-FORTE		SG-ELASTIC Hardness N (ALU) 14 SG-PLUS Hardness H 21	SG-ELASTIC Hardness S (AC-CAST) 16 Hardness S (ZA-CAST) 17	-			
	Hardness K	10	Hardness M	11						
	Hardness P	10	Hardness L	11						
	Hardness L	11	Hardness N (INOX)	14						
	SG-ELASTIC		SG-ELASTIC							
Hardness R	13, 18	Hardness H	20							
SG-PLUS		CC-GRIND®	22							
Hardness H	20	CC-GRIND®-SOLID	24							
Hardness R	15									
CC-GRIND®	22									
CC-GRIND®-SOLID	24									
Chamfering	PS-FORTE		PS-FORTE		-	SG-ELASTIC Hardness S (AC-CAST) 16 Hardness S (ZA-CAST) 17 SG-PLUS Hardness T 17	SG-ELASTIC Hardness Q 16			
	Hardness P	10	Hardness M	11						
	Hardness L	11	Hardness L	11						
	SG-ELASTIC		Hardness N (INOX)	14						
	Hardness R	13, 18	SG-PLUS							
SG-PLUS		CC-GRIND®	22							
Hardness R	15	CC-GRIND®-SOLID	24							
CC-GRIND®	22									
CC-GRIND®-SOLID	24									
Deburring	PS-FORTE		PS-FORTE		-	SG-ELASTIC Hardness S (AC-CAST) 16 Hardness S (ZA-CAST) 17 SG-PLUS Hardness T 17	SG-ELASTIC Hardness Q 16			
	Hardness P	10, 12	Hardness M	11						
	SG-ELASTIC		Hardness P	12						
	Hardness R	13	SG-ELASTIC							
	SG-PLUS		Hardness N (INOX)	14						
Hardness R	15	SG-PLUS								
CC-GRIND®	22	CC-GRIND®	22							
CC-GRIND®-SOLID	24	CC-GRIND®-SOLID	24							
Fillet weld grinding	PS-FORTE		PS-FORTE		SG-ELASTIC Hardness N (ALU) 14 SG-PLUS Hardness H 21	-	-			
	Hardness K	10	Hardness M	11						
	Hardness P	10, 12	Hardness L	11						
	Hardness L	11	SG-ELASTIC							
	SG-ELASTIC		Hardness N (INOX)	14						
Hardness R	13	SG-PLUS								
SG-PLUS		Hardness H	20							
Hardness H	20									
Grouting (Pipeline)	SG-ELASTIC		PS-FORTE		-	-	-			
	Hardness R	18	Hardness M	18						
	Hardness S (ZA)	19	SG-ELASTIC							
		Hardness N (INOX)	19							



### PFERD description

E 178-7 A 30 N SG-INOX/22.23

1 2 3 4 5 6 7 8 9

#### 1 Description and shape of the tool

- E = Reinforced grinding wheel
- ER = Ring wheel
- 50 ETT = Cup wheel (50 m/s)
- CC-GRIND® = Innovative grinding disc

#### 2 Outer diameter

Outer dia. D in [mm]

#### 3 Wheel thickness

Width T or U in [mm]

#### 4 Abrasive

- A = Aluminium oxide
- AC = Aluminium oxide/silicon carbide
- C = Silicon carbide
- CO = Ceramic oxide grain
- ZA = Zirconia alumina/aluminium oxide

#### 5 Grit size according to ISO 8486

#### 6 Hardness grade (wheel properties)

Hardness grade	Wheel properties	Material groups
<b>Universal Line PS-FORTE (PSF)</b>		
K	very soft	Steel
L	soft	Steel/stainless steel (INOX)
M	soft	Stainless steel (INOX)
P	medium-hard	Steel/cast iron
<b>Performance Line SG-ELASTIC (SG)</b>		
M	soft	Steel/stainless steel (INOX)
N	soft	Stainless steel (INOX)/aluminium
Q	medium-hard	Stone/cast iron
R	hard	Steel
S	hard	Casting scale/cast iron
<b>Special Line SG-PLUS (SGP)</b>		
H	very soft	Steel/stainless steel (INOX)
R	hard	Steel
T	very hard	Casting scale/cast iron

#### 7 PFERD product lines

- Universal Line PS-FORTE (PSF)
- Performance Line SG-ELASTIC (SG)
- Special Line SG-PLUS (SGP)

#### 8 Material group

See also point 6

#### 9 Centre hole diameter

Centre hole dia. H in [mm]

### Designation according to EN 12413

27 A 30 N BF 80

1 2 3 4 5 6

#### 1 Designation and shape of the tool

- 1 = Grinding wheel, flat type
- 6 = Cup wheel, cylindrical type
- 11 = Cup wheel, tapered type
- 27 = Grinding wheel, depressed-centre type

#### 2 Abrasives

- A = Aluminium oxide
- AC = Aluminium oxide/silicon carbide
- C = Silicon carbide
- CO = Ceramic oxide grain
- ZA = Zirconia alumina/aluminium oxide

#### 3 Grit size according to ISO 8486

#### 4 Hardness grade (wheel properties)

Abrasive hardness grades are classified using letters in increasing alphabetical order from the softest to hardest (A to Z).

#### 5 Bond

- BF = Fibre-reinforced resinoid bond with cloth
- B = Resinoid bond and other duroplastic organic bonds

#### 6 Maximum operating speed in [m/s]

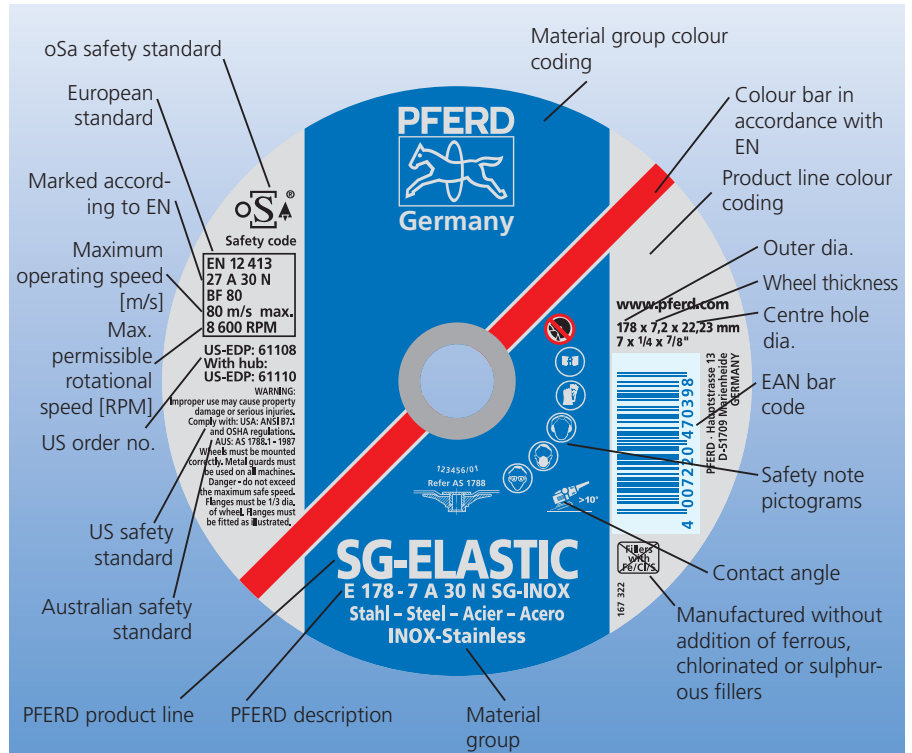

### Colour coding for the three product lines

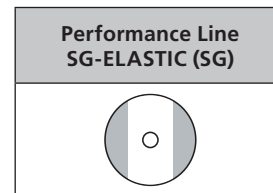
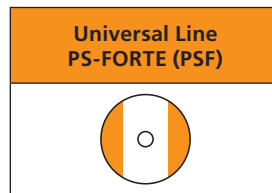

### Colour coding of the materials to be worked

Universal Line PS-FORTE (PSF)		
Material = Colour		Page
	Steel/cast iron = black	10
		12
	Steel/stainless steel (INOX) = black/blue	11
		12
	Stainless steel (INOX) = blue	11
		12
		18

Performance Line SG-ELASTIC (SG)		
Material = Colour		Page
	Steel = black	13
		18
		25
	Stainless steel (INOX) = blue	14
		19
		25
	Non-ferrous metals/aluminium = silver	14
	Casting scale/cast iron/aluminium = silver/red	16
	Steel/cast iron = black/red	17
		19
	Stone/cast iron = green/red	16
		27

Special Line SG-PLUS (SGP)		
Material = Colour		Page
	Steel = black	15
	Steel/stainless steel (INOX) = black/blue	20
	Non-ferrous metals/aluminium = silver	21
	Cast iron = red	17

# Reinforced grinding wheels

## Universal Line PS-FORTE



Very soft general-purpose tool of hardness K, with aggressive grinding performance and long tool life.

**Abrasive: Aluminium oxide A**

**Materials to be worked:**  
Steel

**Applications:**  
Surface grinding, work on weld seams, fillet weld grinding

- Recommendations for use:**
- Suitable for use on angle grinders of all output categories
  - Achieves particularly high stock removal rates even at low contact pressure



Description	EAN 4007220	EN designation	D x U x H [mm (inch)]	Max. perm. speed [RPM]	
E 178-7 A 30 K PSF/22,23	477724	27 A 30 K BF 80	178 x 7.2 x 22.23 (7/8)	8,600	10



Medium-hard general-purpose tool of hardness P, with aggressive grinding performance and long tool life.

**Abrasive: Aluminium oxide A**

**Materials to be worked:**  
Steel, cast iron

**Applications:**  
Surface grinding, work on weld seams, chamfering, deburring, fillet weld grinding

- Recommendations for use:**
- Suitable for use on angle grinders of all output categories
  - Achieves particularly high stock removal rates even at low contact pressure



Description	EAN 4007220	EN designation	D x U x H [mm (inch)]	Max. perm. speed [RPM]	
E 100-6 A 30 P PSF/16,0	653944	27 A 30 P BF 80	100 x 6.3 x 16.0 (5/8)	15,300	10
E 115-7 A 30 P PSF/22,23	470510	27 A 30 P BF 80	115 x 7.2 x 22.23 (7/8)	13,300	10
E 125-7 A 30 P PSF/22,23	471142	27 A 30 P BF 80	125 x 7.2 x 22.23 (7/8)	12,200	10
E 150-7 A 30 P PSF/22,23	952726	27 A 30 P BF 80	150 x 7.2 x 22.23 (7/8)	10,200	10
E 178-7 A 30 P PSF/22,23	470527	27 A 30 P BF 80	178 x 7.2 x 22.23 (7/8)	8,600	10
E 178-8 A 30 P PSF/22,23	470534	27 A 30 P BF 80	178 x 8.3 x 22.23 (7/8)	8,600	10
E 230-7 A 30 P PSF/22,23	470541	27 A 30 P BF 80	230 x 7.2 x 22.23 (7/8)	6,600	10
E 230-8 A 30 P PSF/22,23	470558	27 A 30 P BF 80	230 x 8.3 x 22.23 (7/8)	6,600	10





Soft general-purpose tool of hardness M, with aggressive grinding performance and long tool life.

**Abrasive: Aluminium oxide A**

Manufactured without addition of ferrous, chlorinated or sulphurous fillers.

**Materials to be worked:**

Stainless steel (INOX)

**Applications:**

Surface grinding, work on weld seams, chamfering, deburring, fillet weld grinding, grouting

**Recommendations for use:**

- Suitable for use on angle grinders of all output categories
- Achieves particularly high stock removal rates even at low contact pressure

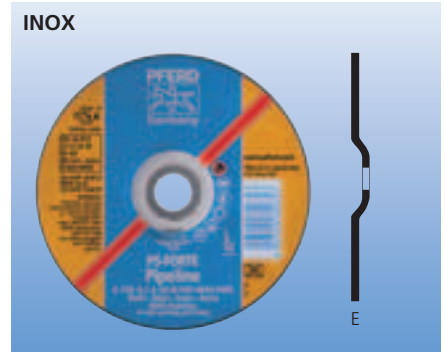

Description	EAN 4007220	EN designation	D x U x H [mm (inch)]	Max. perm. speed [RPM]	
E 100-6 A 30 M PSF-INOX/16,0	471128	27 A 30 M BF 80	100 x 6.3 x 16.0 (5/8)	15,300	10
E 115-7 A 30 M PSF-INOX/22,23	470565	27 A 30 M BF 80	115 x 7.2 x 22.23 (7/8)	13,300	10
E 125-7 A 30 M PSF-INOX/22,23	471159	27 A 30 M BF 80	125 x 7.2 x 22.23 (7/8)	12,200	10
E 150-7 A 30 M PSF-INOX/22,23	471166	27 A 30 M BF 80	150 x 7.2 x 22.23 (7/8)	10,200	10
E 178-7 A 30 M PSF-INOX/22,23	470572	27 A 30 M BF 80	178 x 7.2 x 22.23 (7/8)	8,600	10
E 178-8 A 30 M PSF-INOX/22,23	470589	27 A 30 M BF 80	178 x 8.3 x 22.23 (7/8)	8,600	10
E 230-7 A 30 M PSF-INOX/22,23	470596	27 A 30 M BF 80	230 x 7.2 x 22.23 (7/8)	6,600	10
E 230-8 A 30 M PSF-INOX/22,23	470602	27 A 30 M BF 80	230 x 8.3 x 22.23 (7/8)	6,600	10

Soft general-purpose tool of hardness L, with aggressive grinding performance and long tool life.

A combination tool for steel and stainless steel that optimizes inventory management.

**Abrasive: Aluminium oxide A**

Manufactured without addition of ferrous, chlorinated or sulphurous fillers.

**Materials to be worked:**

Steel, stainless steel (INOX)

**Applications:**

Surface grinding, work on weld seams, chamfering, fillet weld grinding

**Recommendations for use:**

- Suitable for use on angle grinders of all output categories
- Achieves particularly high stock removal rates even at low contact pressure



Description	EAN 4007220	EN designation	D x U x H [mm (inch)]	Max. perm. speed [RPM]	
E 100-6 A 24 L PSF/16,0	643273	27 A 24 L BF 80	100 x 6.3 x 16.0 (5/8)	15,300	10
E 115-7 A 24 L PSF/22,23	640852	27 A 24 L BF 80	115 x 7.2 x 22.23 (7/8)	13,300	10
E 125-7 A 24 L PSF/22,23	640883	27 A 24 L BF 80	125 x 7.2 x 22.23 (7/8)	12,200	10
E 150-7 A 24 L PSF/22,23	641002	27 A 24 L BF 80	150 x 7.2 x 22.23 (7/8)	10,200	10
E 178-7 A 24 L PSF/22,23	640999	27 A 24 L BF 80	178 x 7.2 x 22.23 (7/8)	8,600	10
E 230-7 A 24 L PSF/22,23	640951	27 A 24 L BF 80	230 x 7.2 x 22.23 (7/8)	6,600	10

# Reinforced grinding wheels

## Universal Line PS-FORTE



### DUODISC®

Combination abrasive DUODISC® for cutting and light deburring. Medium-hard tool of hardness P.

#### Advantages:

- Meets highest quality and safety standards through robust, dimensionally and laterally stable disc designs
- Reduced labour costs through savings in set-up times (fewer disc changes)
- High performance through aggressive abrasives and high-quality abrasive grit bonds
- Complies with the requirements of EN 12413

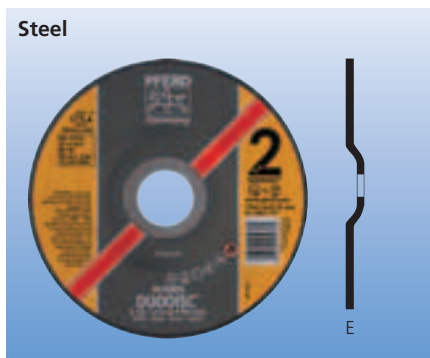

#### Abrasive: Aluminium oxide A

#### Materials to be worked:

Steel

#### Applications:

Cutting, light deburring, light surface grinding, fillet weld grinding, grouting, removal of weld spots

#### Recommendations for use:

- Disc thickness 1.9 mm for fast cutting and deburring
- Disc thicknesses 3.5/2.8 mm for tough operating conditions and very long tool life
- Suitable for use on angle grinders of all output categories

Description	EAN 4007220	EN designation	D x U x H [mm (inch)]	Max. perm. speed [RPM]	
E 115-1,9 A 46 P PSF-DUO/22,23	952771	27 A 46 P BF 80	115 x 1.9 x 22.23 (7/8)	13,300	10
E 115-2,8 A 46 P PSF-DUO/22,23	952788	27 A 46 P BF 80	115 x 2.8 x 22.23 (7/8)	13,300	10
E 125-1,9 A 46 P PSF-DUO/22,23	952795	27 A 46 P BF 80	125 x 1.9 x 22.23 (7/8)	12,200	10
E 125-2,8 A 46 P PSF-DUO/22,23	952801	27 A 46 P BF 80	125 x 2.8 x 22.23 (7/8)	12,200	10
E 150-3,5 A 46 P PSF-DUO/22,23	952818	27 A 46 P BF 80	150 x 3.5 x 22.23 (7/8)	10,200	10

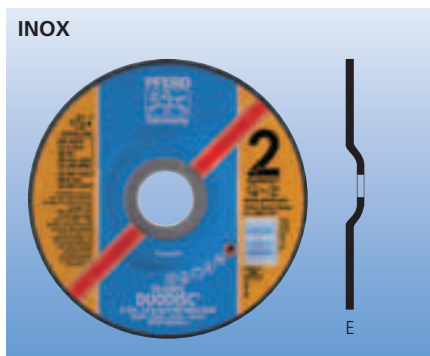

#### Abrasive: Aluminium oxide A

Manufactured without addition of ferrous, chlorinated or sulphurous fillers.

#### Materials to be worked:

Stainless steel (INOX)

#### Applications:

Cutting, light deburring, light surface grinding, fillet weld grinding, grouting, removal of weld spots

#### Recommendations for use:

- Disc thickness 1.9 mm for fast cutting and deburring
- Disc thicknesses 3.5/2.8 mm for tough operating conditions and very long tool life
- Suitable for use on angle grinders of all output categories

Description	EAN 4007220	EN designation	D x U x H [mm (inch)]	Max. perm. speed [RPM]	
E 100-1,9 A 46 P PSF-INOX-DUO/16,0	845578	27 A 46 P BF 80	100 x 1.9 x 16.0 (5/8)	15,300	10
E 100-2,8 A 46 P PSF-INOX-DUO/16,0	952733	27 A 46 P BF 80	100 x 2.8 x 16.0 (5/8)	15,300	10
E 115-1,9 A 46 P PSF-INOX-DUO/22,23	835081	27 A 46 P BF 80	115 x 1.9 x 22.23 (7/8)	13,300	10
E 115-2,8 A 46 P PSF-INOX-DUO/22,23	754498	27 A 46 P BF 80	115 x 2.8 x 22.23 (7/8)	13,300	10
E 125-1,9 A 46 P PSF-INOX-DUO/22,23	835098	27 A 46 P BF 80	125 x 1.9 x 22.23 (7/8)	12,200	10
E 125-2,8 A 46 P PSF-INOX-DUO/22,23	754504	27 A 46 P BF 80	125 x 2.8 x 22.23 (7/8)	12,200	10
E 150-3,5 A 46 P PSF-INOX-DUO/22,23	952740	27 A 46 P BF 80	150 x 3.5 x 22.23 (7/8)	10,200	10
E 178-3,5 A 24 P PSF-INOX-DUO/22,23	952764	27 A 24 P BF 80	178 x 3.5 x 22.23 (7/8)	8,600	10



Hard professional tool of hardness R, with aggressive grinding performance and very long tool life.

For use under high loads.

**Abrasive: Aluminium oxide A**

**Materials to be worked:**

Steel

**E 70-6 A 24 R SG/10.0**

**E 76-6 A 24 R SG/10.0**

**are also suitable for stainless steel (INOX).**

**Applications:**

Surface grinding, work on weld seams, chamfering, deburring, fillet weld grinding, grouting

**Recommendations for use:**

- Achieves optimum grinding results on high-powered angle grinders

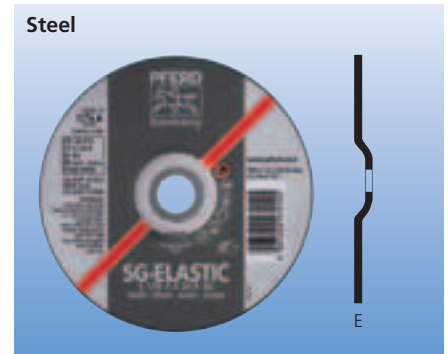

Description	EAN 4007220	EN designation	D x U x H [mm (inch)]	Max. perm. speed [RPM]	
<b>Also for stainless steel (INOX)</b>					
E 70-6 A 24 R SG/10,0	471067	27 A 24 R BF 80	70 x 6.3 x 10.0 (3/8)	21,800	10
E 76-6 A 24 R SG/10,0	471081	27 A 24 R BF 80	76 x 6.3 x 10.0 (3/8)	20,200	10
<b>Steel</b>					
E 100-4 A 24 R SG/16,0	471104	27 A 24 R BF 80	100 x 4.1 x 16.0 (5/8)	15,300	10
E 100-6 A 24 R SG/16,0	471111	27 A 24 R BF 80	100 x 6.3 x 16.0 (5/8)	15,300	10
E 115-4 A 24 R SG/22,23	457634	27 A 24 R BF 80	115 x 4.1 x 22.23 (7/8)	13,300	10
E 115-7 A 24 R SG/22,23	468944	27 A 24 R BF 80	115 x 7.2 x 22.23 (7/8)	13,300	10
E 125-4 A 24 R SG/22,23	457696	27 A 24 R BF 80	125 x 4.1 x 22.23 (7/8)	12,200	10
E 125-7 A 24 R SG/22,23	468951	27 A 24 R BF 80	125 x 7.2 x 22.23 (7/8)	12,200	10
E 150-7 A 24 R SG/22,23	640791	27 A 24 R BF 80	150 x 7.2 x 22.23 (7/8)	10,200	10
E 178-4 A 24 R SG/22,23	478752	27 A 24 R BF 80	178 x 4.1 x 22.23 (7/8)	8,600	10
E 178-7 A 24 R SG/22,23	470145	27 A 24 R BF 80	178 x 7.2 x 22.23 (7/8)	8,600	10
E 178-8 A 24 R SG/22,23	470152	27 A 24 R BF 80	178 x 8.3 x 22.23 (7/8)	8,600	10
E 230-7 A 24 R SG/22,23	470169	27 A 24 R BF 80	230 x 7.2 x 22.23 (7/8)	6,600	10
E 230-8 A 24 R SG/22,23	470176	27 A 24 R BF 80	230 x 8.3 x 22.23 (7/8)	6,600	10





# Reinforced grinding wheels

## Performance Line SG-ELASTIC

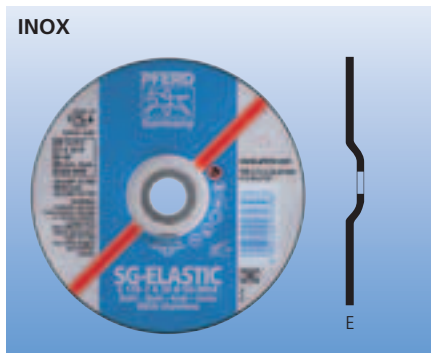

Soft professional tool of hardness N (INOX), with exceptionally aggressive grinding performance and very long tool life.

**Abrasive: Special aluminium oxide A**  
Manufactured without addition of ferrous, chlorinated or sulphurous fillers.

**Materials to be worked:**  
Stainless steel (INOX)

**Applications:**  
Surface grinding, work on weld seams, chamfering, deburring, fillet weld grinding, grouting

**Recommendations for use:**  
■ Provides optimum grinding results on high-powered angle grinders



Description	EAN 4007220	EN designation	D x U x H [mm (inch)]	Max. perm. speed [RPM]	
E 115-4 A 30 N SG-INOX/22,23	457627	27 A 30 N BF 80	115 x 4.1 x 22.23 (7/8)	13,300	10
E 115-7 A 30 N SG-INOX/22,23	470244	27 A 30 N BF 80	115 x 7.2 x 22.23 (7/8)	13,300	10
E 125-4 A 30 N SG-INOX/22,23	457689	27 A 30 N BF 80	125 x 4.1 x 22.23 (7/8)	12,200	10
E 125-5 A 30 N SG-INOX/22,23	520079	27 A 30 N BF 80	125 x 5.2 x 22.23 (7/8)	12,200	10
E 125-7 A 30 N SG-INOX/22,23	470251	27 A 30 N BF 80	125 x 7.2 x 22.23 (7/8)	12,200	10
E 150-7 A 30 N SG-INOX/22,23	332245	27 A 30 N BF 80	150 x 7.2 x 22.23 (7/8)	12,200	10
E 178-7 A 30 N SG-INOX/22,23	470398	27 A 30 N BF 80	178 x 7.2 x 22.23 (7/8)	8,600	10
E 178-8 A 30 N SG-INOX/22,23	470404	27 A 30 N BF 80	178 x 8.3 x 22.23 (7/8)	8,600	10
E 230-7 A 30 N SG-INOX/22,23	470411	27 A 30 N BF 80	230 x 7.2 x 22.23 (7/8)	6,600	10
E 230-8 A 30 N SG-INOX/22,23	470428	27 A 30 N BF 80	230 x 8.3 x 22.23 (7/8)	6,600	10



Soft professional tool of hardness N (ALU), with exceptionally aggressive grinding performance. Operates without tool clogging, even on soft, lubricated materials.

Contains no fillers that might leave undesirable residues on the workpiece. The ground surface can therefore be welded without further treatment.

**Abrasive: Special aluminium oxide A**

**Materials to be worked:**  
Soft and tough aluminium, non-ferrous metals

**Applications:**

Surface grinding, work on weld seams, fillet weld grinding

**Recommendations for use:**

- Achieves outstanding grinding results even at low contact pressure
- Suitable for use on angle grinders of all output categories

Description	EAN 4007220	EN designation	D x U x H [mm (inch)]	Max. perm. speed [RPM]	
E 115-7 A 24 N SG-ALU/22,23	475393	27 A 24 N BF 80	115 x 7.2 x 22.23 (7/8)	13,300	10
E 125-7 A 24 N SG-ALU/22,23	475409	27 A 24 N BF 80	125 x 7.2 x 22.23 (7/8)	12,200	10
E 150-7 A 24 N SG-ALU/22,23	952832	27 A 24 N BF 80	150 x 7.2 x 22.23 (7/8)	10,200	10
E 178-7 A 24 N SG-ALU/22,23	475416	27 A 24 N BF 80	178 x 7.2 x 22.23 (7/8)	8,600	10
E 230-7 A 24 N SG-ALU/22,23	617793	27 A 24 N BF 80	230 x 7.2 x 22.23 (7/8)	6,600	10

Hard special tool of hardness R, with very good grinding performance and outstanding tool life.

For professional work meeting the highest standards.

**Abrasive: Zirconia alumina/ aluminium oxide ZA**

**Materials to be worked:**  
Steel

**Applications:**  
Work on weld seams, chamfering, deburring

**Recommendations for use:**

- Preferably for use on high-powered air and electric angle grinders

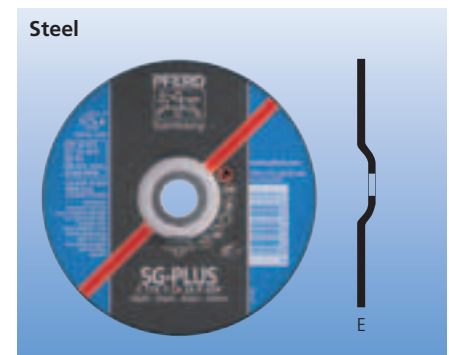

Description	EAN 4007220	EN designation	D x U x H [mm (inch)]	Max. perm. speed [RPM]	
E 115-7 ZA 24 R SGP/22,23	640913	27 ZA 24 R BF 80	115 x 7.2 x 22.23 (7/8)	13,300	10
E 125-7 ZA 24 R SGP/22,23	640920	27 ZA 24 R BF 80	125 x 7.2 x 22.23 (7/8)	12,200	10
E 150-7 ZA 24 R SGP/22,23	640784	27 ZA 24 R BF 80	150 x 7.2 x 22.23 (7/8)	10,200	10
E 178-7 ZA 24 R SGP/22,23	640937	27 ZA 24 R BF 80	178 x 7.2 x 22.23 (7/8)	8,600	10
E 230-7 ZA 24 R SGP/22,23	640944	27 ZA 24 R BF 80	230 x 7.2 x 22.23 (7/8)	6,600	10



# Reinforced grinding wheels

## Performance Line SG-ELASTIC

### Foundry reinforced grinding wheels

For the hard conditions encountered on air turbine grinders and strong high-frequency or electric angle grinders in foundries, PFERD has developed reinforced grinding wheels which meet particularly high quality and safety standards.

Materials such as casting scale with sand contamination, cast iron, cast iron with flake graphite, cast iron with nodular graphite/nodular cast iron, as well as steel can be worked outstandingly.

General plaster work, surface grinding, chamfering and deburring are the most common applications in tough foundry use.

For all matters relating to work in foundries, PFERD offers you targeted and individual support. Our experienced sales representatives and technical advisors will be pleased to assist you. Please contact us.

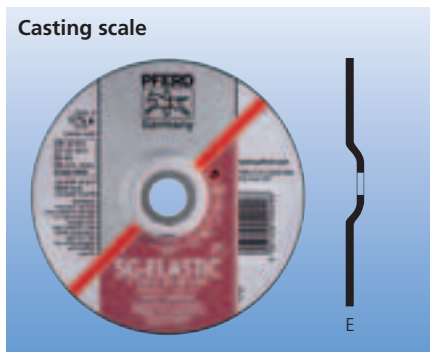

Hard professional tool of hardness S (AC-CAST), with aggressive grinding performance and very long tool life.

**Abrasive: Aluminium oxide/ silicon carbide AC**

**Materials to be worked:**

Casting scale with sand contamination, cast iron with flake graphite, cast iron with nodular graphite/nodular cast iron, hard aluminium

**Applications:**

Surface grinding, work on weld seams, chamfering, deburring

**Recommendations for use:**

- Preferably for use on high-powered angle grinders
- Provides optimum grinding results on air turbine grinders and powerful high-frequency or electric angle grinders



Description	EAN 4007220	EN designation	D x U x H [mm (inch)]	Max. perm. speed [RPM]	
E 178-7 AC 30 S SG/22,23	520208	27 AC 30 S BF 80	178 x 7.2 x 22.23 (7/8)	8,600	10
E 230-7 AC 30 S SG/22,23	520215	27 AC 30 S BF 80	230 x 7.2 x 22.23 (7/8)	6,600	10



Medium-hard professional tool of hardness Q, with aggressive grinding performance and very long tool life.

**Abrasive: Silicon carbide C**

**Materials to be worked:**

Cast iron/casting scale, stone, hard aluminium

**Applications:**

Surface grinding, chamfering, deburring

**Recommendations for use:**

- Preferably for use on high-powered angle grinders
- Provides optimum grinding results on air turbine grinders and powerful high-frequency or electric angle grinders



Description	EAN 4007220	EN designation	D x U x H [mm (inch)]	Max. perm. speed [RPM]	
E 115-7 C 24 Q SG/22,23	471135	27 C 24 Q BF 80	115 x 7.2 x 22.23 (7/8)	13,300	10
E 125-7 C 24 Q SG/22,23	643303	27 C 24 Q BF 80	125 x 7.2 x 22.23 (7/8)	12,200	10
E 178-7 C 24 Q SG/22,23	471173	27 C 24 Q BF 80	178 x 7.2 x 22.23 (7/8)	8,600	10
E 230-7 C 24 Q SG/22,23	329290	27 C 24 Q BF 80	230 x 7.2 x 22.23 (7/8)	6,600	10



Hard professional tool of hardness S (ZA-CAST), with outstanding grinding performance and very long tool life.

**Abrasive: Zirconia alumina/ aluminium oxide ZA**

**Materials to be worked:**

Cast iron with flake graphite, cast iron with nodular graphite/nodular cast iron, steel

**Applications:**

Surface grinding, work on weld seams, chamfering, deburring, grouting

**Recommendations for use:**

- Preferably for use on high-powered angle grinders
- Provides optimum grinding results on air turbine grinders and powerful high-frequency or electric angle grinders



Description	EAN 4007220	EN designation	D x U x H [mm (inch)]	Max. perm. speed [RPM]	
E 115-7 ZA 30 S SG/22,23	802359	27 ZA 30 S BF 80	115 x 7.2 x 22.23 (7/8)	13,300	10
E 125-7 ZA 30 S SG/22,23	802380	27 ZA 30 S BF 80	125 x 7.2 x 22.23 (7/8)	12,200	10
E 178-7 ZA 30 S SG/22,23	470435	27 ZA 30 S BF 80	178 x 7.2 x 22.23 (7/8)	8,600	10
E 178-8 ZA 30 S SG/22,23	470480	27 ZA 30 S BF 80	178 x 8.3 x 22.23 (7/8)	8,600	10
E 230-5 ZA 30 S SG/22,23	640876	27 ZA 30 S BF 80	230 x 5.2 x 22.23 (7/8)	6,600	10
E 230-7 ZA 30 S SG/22,23	470459	27 ZA 30 S BF 80	230 x 7.2 x 22.23 (7/8)	6,600	10
E 230-8 ZA 30 S SG/22,23	470503	27 ZA 30 S BF 80	230 x 8.3 x 22.23 (7/8)	6,600	10



Very hard high-performance tool of hardness T, with outstanding grinding performance and tool life. For industrial use under severe operating conditions.

**Abrasive: Zirconia alumina/ aluminium oxide ZA**

**Materials to be worked:**

Cast iron with flake graphite, cast iron with nodular graphite/nodular cast iron, scale

**Applications:**

Surface grinding, chamfering, deburring

**Recommendations for use:**

- Provides optimum grinding results on air turbine grinders and powerful high-frequency or electric angle grinders

## Special Line SG-PLUS



Description	EAN 4007220	EN designation	D x U x H [mm (inch)]	Max. perm. speed [RPM]	
E 178-7 ZA 30 T SGP/22,23	640906	27 ZA 30 T BF 80	178 x 7.2 x 22.23 (7/8)	8,600	10
E 178-8 ZA 30 T SGP/22,23	802403	27 ZA 30 T BF 80	178 x 8.3 x 22.23 (7/8)	8,600	10
E 230-7 ZA 30 T SGP/22,23	640890	27 ZA 30 T BF 80	230 x 7.2 x 22.23 (7/8)	6,600	10
E 230-8 ZA 30 T SGP/22,23	802410	27 ZA 30 T BF 80	230 x 8.3 x 22.23 (7/8)	6,600	10

# Reinforced grinding wheels

## Universal Line PS-FORTE

### Pipeline reinforced grinding wheels

Extreme weather and hard working conditions, tough applications and high physical loads characterize the work in pipeline construction.

PFERD tools are used where there are high demands on efficient work and the quality of the work results. No matter what applications need to be resolved – rust removal, deburring, cleaning of welds and root welds – PFERD tools are ideally suited for all pipeline construction tasks.

Our aim: Optimum work results and the highest economic value with PFERD tools for pipeline construction.

For all matters relating to work in pipeline construction, PFERD offers you targeted and individual support. Our experienced sales representatives and technical advisors will be pleased to assist you. Please contact us.



#### PFERD INFORMATION

You will receive more information here or at [www.pferd.com](http://www.pferd.com)

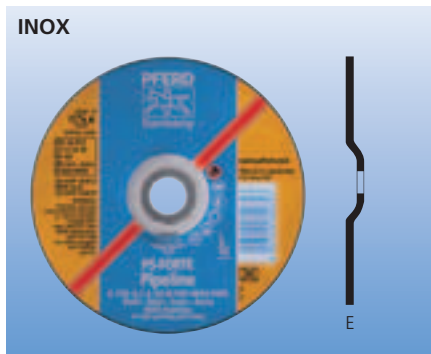

Soft general-purpose tool of hardness M, with aggressive grinding performance and long tool life.

Particularly shape-stable for use in pipeline construction.

#### Abrasive: Aluminium oxide A

Manufactured without addition of ferrous, chlorinated or sulphurous fillers.

#### Materials to be worked:

Stainless steel (INOX)

#### Applications:

Surface grinding, work on weld seams, chamfering, deburring, fillet weld grinding, grouting

#### Recommendations for use:

- Suitable for use on angle grinders of all output categories
- Achieves outstanding grinding results even at low contact pressure

Description	EAN 4007220	EN designation	D x U x H [mm (inch)]	Max. perm. speed [RPM]	
E 115-4,1 A 46 M PSF-INOX-PIPE/22,23	640869	27 A 46 M BF 80	115 x 4.1 x 22.23 (7/8)	13,300	10
E 150-4,1 A 30 M PSF-INOX-PIPE/22,23	807774	27 A 30 M BF 80	150 x 4.1 x 22.23 (7/8)	10,200	10
E 178-4,1 A 24 M PSF-INOX-PIPE/22,23	640753	27 A 24 M BF 80	178 x 4.1 x 22.23 (7/8)	8,600	10
E 178-4,6 A 24 M PSF-INOX-PIPE/22,23	807781	27 A 24 M BF 80	178 x 4.6 x 22.23 (7/8)	8,600	10



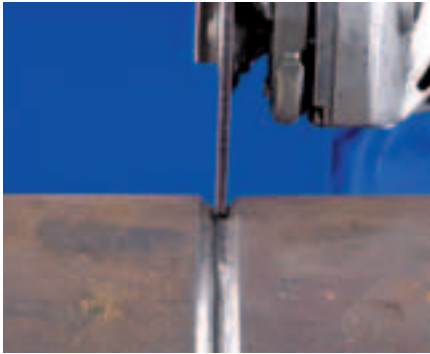

Hard professional tool of hardness R, with aggressive grinding performance and very long tool life.  
For use under high load.  
Particularly shape-stable for use in pipeline construction.

**Abrasive: Aluminium oxide A**

**Materials to be worked:**  
Steel

**Applications:**  
Surface grinding, work on weld seams, chamfering, deburring, fillet weld grinding, grouting

**Recommendations for use:**  
■ Optimum grinding results on high-powered angle grinders



Description	EAN 4007220	EN designation	D x U x H [mm (inch)]	Max. perm. speed [RPM]	
E 115-4,1 A 24 R SG PIPE/22,23	640845	27 A 24 R BF 80	115 x 4.1 x 22.23 (7/8)	13,300	10
E 178-4,1 A 24 R SG PIPE/22,23	640746	27 A 24 R BF 80	178 x 4.1 x 22.23 (7/8)	8,600	10

Soft professional tool of hardness N (INOX), with exceptionally aggressive grinding performance and very long tool life.  
Particularly shape-stable for use in pipeline construction.

**Abrasive: Special aluminium oxide A**  
Manufactured without addition of ferrous, chlorinated or sulphurous fillers.

**Materials to be worked:**  
Stainless steel (INOX)

**Applications:**  
Surface grinding, work on weld seams, chamfering, deburring, fillet weld grinding, grouting

**Recommendations for use:**  
■ Provides optimum grinding results on high-powered angle grinders

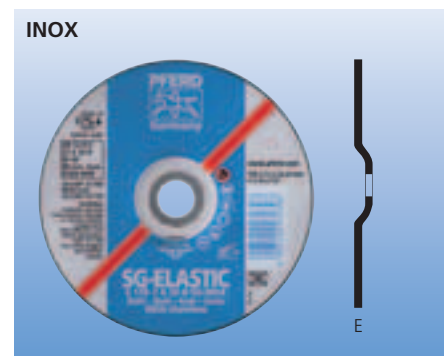

Description	EAN 4007220	EN designation	D x U x H [mm (inch)]	Max. perm. speed [RPM]	
E 178-4,1 A 30 N SG-INOX-PIPE/22,23	475287	27 A 30 N BF 80	178 x 4.1 x 22.23 (7/8)	8,600	10

Hard professional tool of hardness S, with outstanding grinding performance and very long tool life.  
Particularly shape-stable for use in pipeline construction.

**Abrasive: Zirconia alumina/ aluminium oxide ZA**

**Materials to be worked:**  
Steel, cast iron

**Applications:**  
Surface grinding, work on weld seams, chamfering, deburring, grouting

**Recommendations for use:**  
■ Preferably for use on high-powered angle grinders  
■ Provides optimum grinding results on air turbine grinders and powerful high-frequency or electric angle grinders

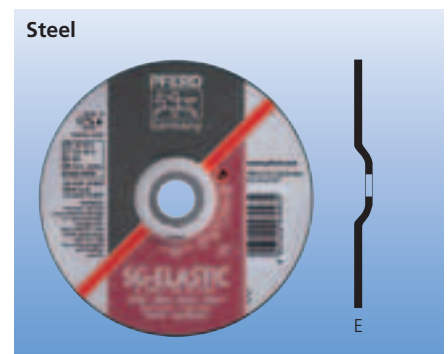

Description	EAN 4007220	EN designation	D x U x H [mm (inch)]	Max. perm. speed [RPM]	
E 178-4,1 ZA 30 S SG PIPE/22,23	640777	27 ZA 30 S BF 80	178 x 4.1 x 22.23 (7/8)	8,600	10
E 178-4,6 ZA 30 S SG PIPE/22,23	807804	27 ZA 30 S BF 80	178 x 4.6 x 22.23 (7/8)	8,600	10
E 230-4,1 ZA 30 S SG PIPE/22,23	640760	27 ZA 30 S BF 80	230 x 4.1 x 22.23 (7/8)	6,600	10
E 230-4,6 ZA 30 S SG PIPE/22,23	807811	27 ZA 30 S BF 80	230 x 4.6 x 22.23 (7/8)	6,600	10



# Reinforced grinding wheels

## Special Line SG-PLUS

### WHISPER

PFERD is working, in particular, on sustainably reducing the noise and vibration generated during the use of grinding tools and on significantly improving the comfort for the user.

Through its patented design, the reinforced grinding wheel WHISPER creates noticeably less vibration and significantly less noise than conventional reinforced grinding wheels. The noise exposure is reduced by up to 12 dB(A), representing a reduction of more than 90 %.

In addition, the flexible tool structure allows soft and comfortable grinding with excellent surface quality.

The reinforced grinding wheel WHISPER is a high-performance tool with an impressive machining capacity for exceptionally high stock removal. The increased productivity of the grinding process results in substantial savings in labour costs.

**PFERDERGONOMICS®** recommends the reinforced grinding wheel WHISPER to sustainably reduce vibration and noise levels generated during use and to improve the grinding comfort.



#### PFERDVIDEO

You will receive more information here or at [www.pferd.com](http://www.pferd.com)



#### INOX/steel



Very soft high-performance tool of hardness H. Very suitable when high stock removal and excellent surface qualities need to be achieved economically.

**Abrasive: Aluminium oxide A**

**Materials to be worked:**

Stainless steel (INOX), steel

**Applications:**

Surface grinding, work on weld seams, fillet weld grinding

#### Recommendations for use:

- Suitable for use on angle grinders of all output categories
- Wheel thickness 5.3 mm for Hardox, scale layers, mill scale

**PFERDERGONOMICS®:**



Description	EAN 4007220	EN designation	D x U x H [mm (inch)]	Max. perm. speed [RPM]	
E 115-5 A 46 H SGP-WHISPER/22,23	952849	27 A 46 H BF 80	115 x 5.3 x 22.23 (7/8)	13,300	10
E 115-7 A 46 H SGP-WHISPER/22,23	827505	27 A 46 H BF 80	115 x 7.4 x 22.23 (7/8)	13,300	10
E 125-5 A 46 H SGP-WHISPER/22,23	952856	27 A 46 H BF 80	125 x 5.3 x 22.23 (7/8)	12,200	10
E 125-7 A 46 H SGP-WHISPER/22,23	827512	27 A 46 H BF 80	125 x 7.4 x 22.23 (7/8)	12,200	10



Very soft special tool of hardness H, with exceptionally aggressive grinding performance. Operates without tool clogging even on soft, lubricating aluminium.

Contains no fillers that might leave undesirable residues on the workpiece. The ground surface can therefore be welded without further treatment.

**Abrasive: Special aluminium oxide A**

**Materials to be worked:**

Aluminium, non-ferrous metals

**Applications:**

Surface grinding, work on weld seams, fillet weld grinding

**Recommendations for use:**

■ Suitable for use on angle grinders of all output categories

**PFERDERGONOMICS®:**



Description	EAN 4007220	EN designation	D x U x H [mm (inch)]	Max. perm. speed [RPM]	
E 115-7 A 46 H SGP-WHISPER-ALU/22,23	853443	27 A 46 H BF 80	115 x 7.4 x 22.23 (7/8)	13,300	10
E 125-7 A 46 H SGP-WHISPER-ALU/22,23	853450	27 A 46 H BF 80	125 x 7.4 x 22.23 (7/8)	12,200	10



# CC-GRIND® grinding discs

## Performance Line SG

PFERD presents a newly developed, patented quick-mounting and cooling system for use with grinding discs in surface and contour grinding. This quick-mounting system and the high-performance abrasive guarantee ultimate stock removal rates.

The CC-GRIND® grinding disc combines novel backing pads and stable clamping on the rear side of the grinding wheel. With the new backing pad, all CC-GRIND® grinding discs can be used on commercially available angle grinders.

The quick-mounting system, stable clamping, secure locking of the tool and the optimized cooling system lead to a considerable increase in aggressiveness and tool life of the grinding discs. Noise and vibration are reduced by 50 %, dust by 80 %. The tool temperature is reduced by 30 %.

**Flexible grinding:**  
Soft and flexible grinding performance with CC-GRIND® grinding discs.

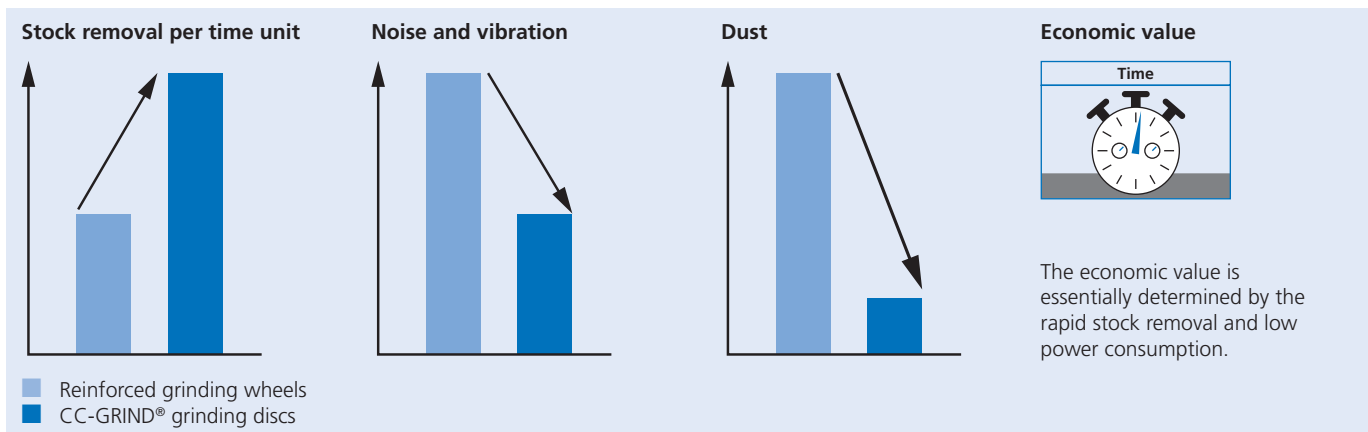

### Advantages:

#### System



Very easy and comfortable use.

#### Clamping



Extremely fast and easy tool change reduces process costs.

#### Cooling effect

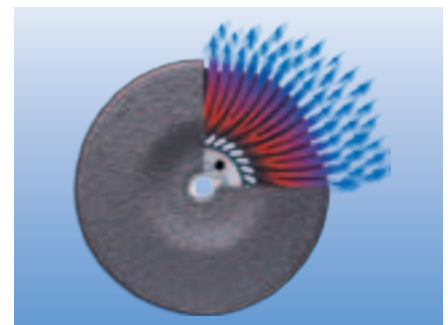

Cooling of the tool and the workpiece by the patented cooling system.

#### CC-GRIND® grinding discs allow very flat use!

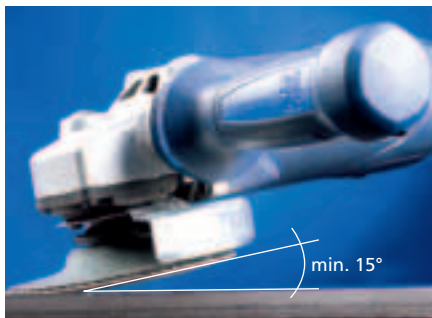

To date: Use with conventional fibre discs

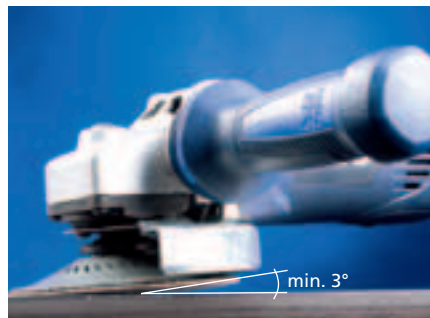

**Use with CC-GRIND® grinding discs**

Scratches caused by protruding metal parts are avoided and very high utilization of the available abrasive is attained.

PFERDERGONOMICS® recommends the CC-GRIND® grinding disc to sustainably reduce vibration, noise and dust levels generated during use and to improve working comfort.

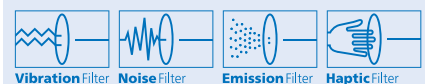

#### PFERDVIDEO

You will receive more information here or at [www.pferd.com](http://www.pferd.com)



STEEL type for ultimate stock removal rates on steel.

**Materials to be worked:**  
Steel

**Applications:**  
Surface grinding, work on weld seams

- Recommendations for use:**
- Only use with the face of the disc, not suitable for circumferential grinding
  - Avoid use on sharp edges, as far as possible, to prevent tool damage

**Ordering note:**  
Please order backing pad separately.



CC-GRIND® grinding discs  
Type STEEL

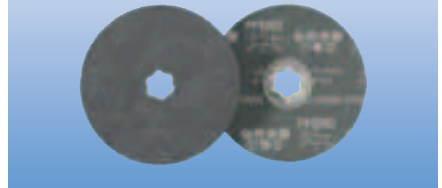

Description	EAN 4007220	D [mm]	Suitable backing pads	Max. perm. speed [RPM]	
CC-GRIND 115 SG-STEEL	835876	115	GT CC-GRIND-STEEL 115/125 M14	13,300	25
CC-GRIND 125 SG-STEEL	835883	125	GT CC-GRIND-INOX 115/125 M14	12,200	25

INOX type for grinding with low heat build-up and very good stock removal rate on stainless steel (INOX).

**Materials to be worked:**  
Stainless steel (INOX)

**Applications:**  
Surface grinding, work on weld seams

- Recommendations for use:**
- Only use with the face of the disc, not suitable for circumferential grinding.
  - Avoid use on sharp edges, as far as possible, to prevent tool damage

**Ordering note:**  
Please order backing pad separately.



CC-GRIND® grinding discs  
Type INOX

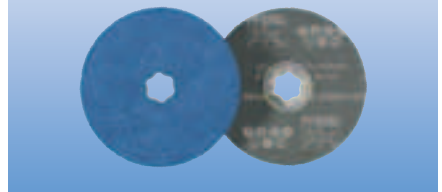

Description	EAN 4007220	D [mm]	Suitable backing pads	Max. perm. speed [RPM]	
CC-GRIND 115 SG-INOX	835890	115	GT CC-GRIND-STEEL 115/125 M14	13,300	25
CC-GRIND 125 SG-INOX	835906	125	GT CC-GRIND-INOX 115/125 M14	12,200	25

With this backing pad, CC-GRIND® grinding discs can be used on commercially available angle grinders.

The geometry of the cooling slits ensures high air flow. This significantly reduces the thermal load on the abrasive and the tool.

The patented quick-mounting and cooling system reduces tool changing times to a minimum.

The special backing pad design significantly increases grinding performance.

Type STEEL = grey (medium-hard)  
Type INOX = blue (hard)

- Safety notes:**
- The maximum permitted peripheral speed is 80 m/s

## CC-GRIND® backing pads

CC-GRIND® backing pads  
Type STEEL/INOX

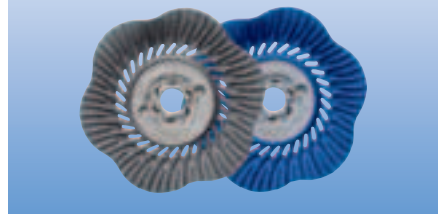

Description	EAN 4007220	Thread	Suitable for machine types	
GT CC-GRIND-STEEL 115/125 M14	835852	M14	Angle grinders 115 / 125, spindle M14	1
GT CC-GRIND-INOX 115/125 M14	835869	M14	Angle grinders 115 / 125, spindle M14	1

# CC-GRIND® grinding discs

## Performance Line SG

### CC-GRIND®-SOLID

PFERD presents the new robust CC-GRIND®-SOLID for hard and tough grinding processes. The further development of the PFERD innovation CC-GRIND® is characterized by an integrated glass fibre backing pad in combination with high-performance abrasive grain and a special clamping system.

The innovative high-strength layer structure of the glass fibre backing pad guarantees the same robust and secure use as with a reinforced grinding wheel.

The CC-GRIND®-SOLID grinding disc meets all the safety requirements of a reinforced grinding wheel in accordance with EN 12413, in particular the side load test.

Noise and vibration are reduced by 50 %, dust by 80 %.

The grinding disc is optimally aligned due to the special clamping system and can thus be used particularly flat and efficiently.

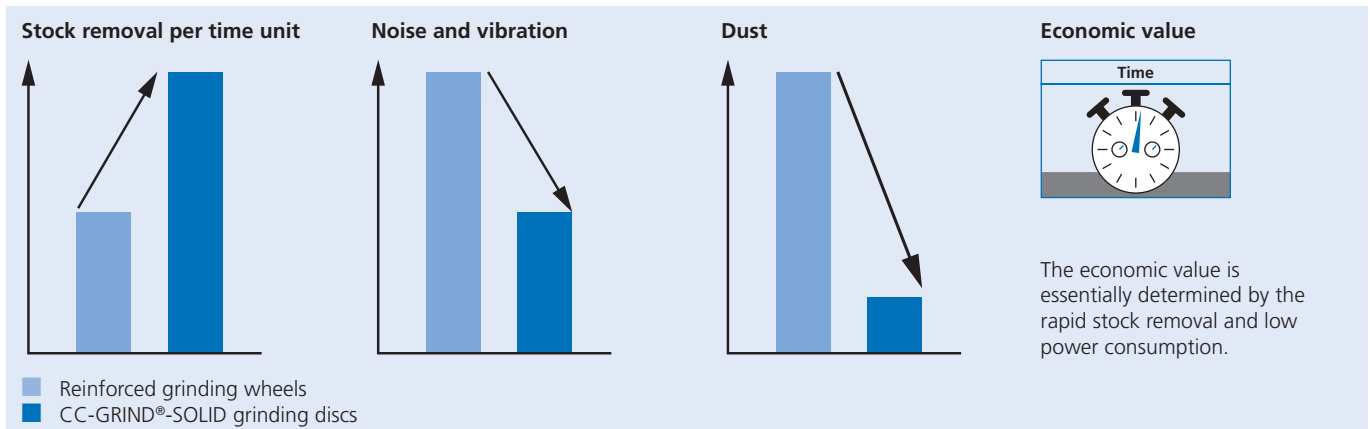

### Advantages:

#### Layered structure



Innovative high-strength tool construction for particularly ergonomic and safe work.

#### Hard and rough use



Integrated glass fibre backing pad for hard and tough use, and for work on edges.



#### Special clamping system

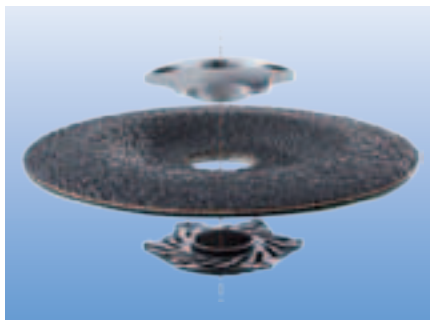

Fast and easy tool change. The unique clamping system allows an extremely flat use and optimum utilization of the available abrasive.



PFERDERGONOMICS® recommends the CC-GRIND®-SOLID grinding disc to sustainably reduce vibration, noise and dust levels generated during use and to improve working comfort.

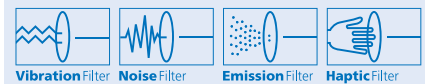

#### PFERDVIDEO

You will receive more information here or at [www.pferd.com](http://www.pferd.com)



STEEL type for ultimate stock removal rates on steel.

**Materials to be worked:**  
Steel

**Applications:**  
Surface grinding, work on weld seams, chamfering, deburring, work on edges

**Recommendations for use:**  
■ Only use the face of the disc, not suitable for circumferential grinding

**Ordering note:**  
Please order clamping flange set SFS separately.

PFERDERGONOMICS®:



### CC-GRIND®-SOLID grinding discs Type STEEL



Description	EAN 4007220	D [mm]	Suitable clamping flange set	Max. perm. speed [RPM]	
CC-GRIND-SOLID 100 SG-STEEL	919682	100	SFS CC-GRIND-SOLID 100 M10, SFS CC-GRIND-SOLID 100 3/8"	15,300	10
CC-GRIND-SOLID 115 SG-STEEL	887059	115	SFS CC-GRIND-SOLID 115/125 M14, SFS CC-GRIND-SOLID 115/125 5/8"	13,300	10
CC-GRIND-SOLID 125 SG-STEEL	887073	125	SFS CC-GRIND-SOLID 115/125 M14, SFS CC-GRIND-SOLID 115/125 5/8"	12,200	10
CC-GRIND-SOLID 150 SG-STEEL	952894	150	SFS CC-GRIND-SOLID 180 M14, SFS CC-GRIND-SOLID 180 5/8"	10,200	10
CC-GRIND-SOLID 180 SG-STEEL	887080	180	SFS CC-GRIND-SOLID 180 M14, SFS CC-GRIND-SOLID 180 5/8"	8,500	10



INOX type for very good stock removal rates on stainless steel (INOX).

**Materials to be worked:**  
Stainless steel (INOX)

**Applications:**  
Work on weld seams, chamfering, deburring, work on edges

**Recommendations for use:**  
■ Only use the face of the disc, not suitable for circumferential grinding

**Ordering note:**  
Please order clamping flange set SFS separately.

PFERDERGONOMICS®:



### CC-GRIND®-SOLID grinding discs Type INOX



Description	EAN 4007220	D [mm]	Suitable clamping flange set	Max. perm. speed [RPM]	
CC-GRIND-SOLID 115 SG-INOX	900895	115	SFS CC-GRIND-SOLID 115/125 M14, SFS CC-GRIND-SOLID 115/125 5/8"	13,300	10
CC-GRIND-SOLID 125 SG-INOX	900901	125	SFS CC-GRIND-SOLID 115/125 M14, SFS CC-GRIND-SOLID 115/125 5/8"	12,200	10
CC-GRIND-SOLID 180 SG-INOX	900918	180	SFS CC-GRIND-SOLID 180 M14, SFS CC-GRIND-SOLID 180 5/8"	8,500	10



# CC-GRIND® grinding discs

## CC-GRIND®-SOLID clamping flange sets

### CC-GRIND®-SOLID clamping flange sets

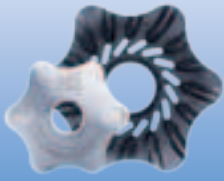

With this special clamping flange set, only the original PFERD CC-GRIND®-SOLID grinding discs can be used on commercially available angle grinders.

#### Safety notes:

- The maximum permitted peripheral speed is 80 m/s

Description	EAN 4007220	Thread	Suitable for machine types	
SFS CC-GRIND-SOLID 100 M10	932209	M10	Angle grinders 100, spindle M10	1
SFS CC-GRIND-SOLID 100 3/8"	932216	3/8	Angle grinder 100, holder 3/8"	1
SFS CC-GRIND-SOLID 115/125 M14	887578	M14	Angle grinders 115 / 125, spindle M14	1
SFS CC-GRIND-SOLID 115/125 5/8"	887592	5/8	Angle grinders 115 / 125, spindle 5/8"	1
SFS CC-GRIND-SOLID 150/180 M14	887585	M14	Angle grinders 150 / 180, spindle M14	1
SFS CC-GRIND-SOLID 150/180 5/8"	887608	5/8	Angle grinders 150 / 180, spindle 5/8"	1



Starting with the application ❶ and material ❷, the overview shows the various types of tools in the PFERD range and helps you to find the best tool.

❶ Application	❷ Material			
	Steel	INOX	Casting scale/cast iron	Stone
	Type	Type	Type	Type
Surface grinding	A 16	A 16	C 16	C 16-80
Work on weld seams	A 16	A 16	-	-
Chamfering	A 24	A 24	C 24	C 60/80
Deburring	A 36/80	A 36/80	C 30	-

Medium-hard general-purpose tool of hardness Q with aggressive grinding performance and long tool life.

**Abrasive: Aluminium oxide A**

Manufactured without addition of ferrous, chlorinated or sulphurous fillers.

**Materials to be worked:**

Steel, stainless steel (INOX)

**Applications:**

Work on weld seams, chamfering, deburring, surface grinding

**Recommendations for use:**

- Suitable for high-powered angle grinders
- Working at a slight angle allows work on welds

**Safety notes:**

- The maximum permitted operating speed is 50 m/s. Please observe the rotational speeds of the angle grinder.

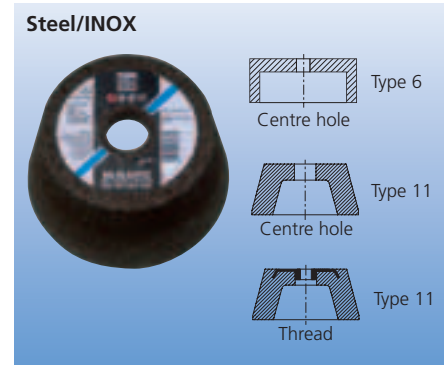

Description	EAN 4007220	Centre hole dia. H [mm]	Thread H	Outer dia. D [mm]	Smallest dia. J [mm]	Width T [mm]	Wall thickness W [mm]	Max. perm. speed [RPM]	
50 ETT 80-8 A 36 Q SG/22,23	698419	22.23	-	80	80	27	8	11,900	5
50 ETT 80-8 A 80 Q SG/22,23	164785	22.23	-	80	80	27	8	11,900	5
50 ETT 110-20 A 16 Q SG/22,23	164730	22.23	-	110	90	55	20	8,600	2
50 ETT 110-20 A 24 Q SG/22,23	803103	22.23	-	110	90	55	20	8,600	2
50 ETT 110-20 A 36 Q SG/22,23	803127	22.23	-	110	90	55	20	8,600	2
50 ETT 125-25 A 16 Q SG/M14	164747	-	M14	125	95	51	25	7,600	2

Medium-hard general-purpose tool of hardness Q with aggressive grinding performance and long tool life.

**Abrasive: Silicon carbide C**

**Materials to be worked:**  
 Natural and synthetic stone, cast iron, casting scale

**Applications:**

Wet grinding, dry grinding, surface grinding, chamfering, deburring

**Recommendations for use:**

- Suitable for high-powered angle grinders

**Safety notes:**

- The maximum permitted operating speed is 50 m/s. Please observe the rotational speeds of the angle grinder.

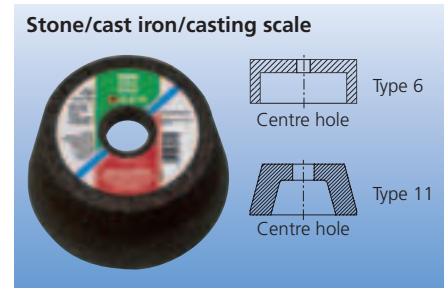

Description	EAN 4007220	Centre hole dia. H [mm]	Outer dia. D [mm]	Smallest dia. J [mm]	Width T [mm]	Wall thickness W [mm]	Max. perm. speed [RPM]	
50 ETT 80-8 C 80 Q SG/22,23	164822	22.23	80	80	27	8	11,900	5
50 ETT 110-20 C 16 Q SG/22,23	164808	22.23	110	90	55	20	8,600	2
50 ETT 110-20 C 24 Q SG/22,23	803134	22.23	110	90	55	20	8,600	2
50 ETT 110-20 C 30 Q SG/22,23	164815	22.23	110	90	55	20	8,600	2
50 ETT 110-20 C 60 Q SG/22,23	803141	22.23	110	90	55	20	8,600	2

# Ring wheels

## Performance Line SG-ELASTIC

### Steel/INOX/cast iron



Soft, general-purpose tool of hardness M with aggressive grinding performance and long tool life.

#### Abrasive: Aluminium oxide A

Manufactured without addition of ferrous, chlorinated or sulphurous fillers.

#### Materials to be worked:

Steel, stainless steel (INOX), cast iron

#### Applications:

Work on weld seams, chamfering, deburring, grouting in hard-to-reach places

#### Recommendations for use:

- Use for peripheral grinding
- Ring wheels up to dia. 76 mm can be used without a guard

#### Safety notes:

- When used with an arbor on a straight grinder, can be used up to the maximum permissible rotational speed of the arbor

Description	EAN 4007220	EN designation	D x T x H [mm (inch)]	Max. perm. speed [RPM] of the ring wheel without arbor	Max. perm. speed [RPM] of the ring wheel with PFERD arbor	Suitable arbors	
ER 30-4 A 24 M SG/6,0	165423	1 A 24 M BF 80	30 x 4.2 x 6.0 (1/4)	51,000	31,800	BO 6/6 3-10	20
ER 30-6 A 24 M SG/6,0	165430	1 A 24 M BF 80	30 x 6.2 x 6.0 (1/4)	51,000	31,800	BO 6/6 3-10	20
ER 40-4 A 24 M SG/6,0	165447	1 A 24 M BF 80	40 x 4.2 x 6.0 (1/4)	38,200	23,900	BO 6/6 3-10	20
ER 40-6 A 24 M SG/6,0	165454	1 A 24 M BF 80	40 x 6.2 x 6.0 (1/4)	38,200	23,900	BO 6/6 3-10	20
ER 50-6 A 24 M SG/6,0	165461	1 A 24 M BF 80	50 x 6.2 x 6.0 (1/4)	30,600	19,100	BO 6/6 3-10	20
ER 50-10 A 24 M SG/6,0	165485	1 A 24 M BF 80	50 x 10.5 x 6.0 (1/4)	30,600	19,100	BO 6/6 3-10	20
ER 50-10 A 24 M SG/10,0	165492	1 A 24 M BF 80	50 x 10.5 x 10.0 (25/64)	30,600	19,100	BO 8/10 6-20	20
ER 70-6 A 24 M SG/10,0	165508	1 A 24 M BF 80	70 x 6.2 x 10.0 (25/64)	21,800	13,600	BO 8/10 6-20, BO 8/10 4-8	20
ER 70-8 A 24 M SG/10,0	165805	1 A 24 M BF 80	70 x 8.7 x 10.0 (25/64)	21,800	13,600	BO 8/10 6-20, BO 8/10 4-8	20
ER 70-10 A 24 M SG/10,0	165515	1 A 24 M BF 80	70 x 10.5 x 10.0 (25/64)	21,800	13,600	BO 8/10 6-20	20
ER 70-15 A 24 M SG/10,0	165539	1 A 24 M BF 80	70 x 15.7 x 10.0 (25/64)	21,800	13,600	BO 8/10 6-20	20

## Arbors for ring wheels/cut-off wheels

### Arbors for ring wheels

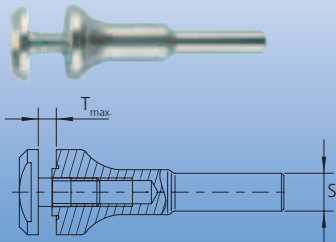

Accessories for clamping ring wheels on straight grinders. Stable type with maximum shank fracture resistance.

#### Safety notes:

- When using this arbor, please observe the maximum permissible rotational speed indicated on the instruction sheet. Arbors with mounted ring wheels can be used up to the maximum speed permitted for the arbor (see table).

Tool dia. [mm]	Max. perm. speed [RPM]
30	31,800
40	23,900
50	19,100
70	13,600

Description	EAN 4007220	Shank dia. S [mm]	Tool centre hole dia. [mm]	Max. tool width T <sub>max</sub> [mm]	
BO 6/6 3-10	297650	6	6	3-10	1
BO 8/10 6-20	297667	8	10	6-20	1
BO 8/10 4-8	103623	8	10	4-8	1



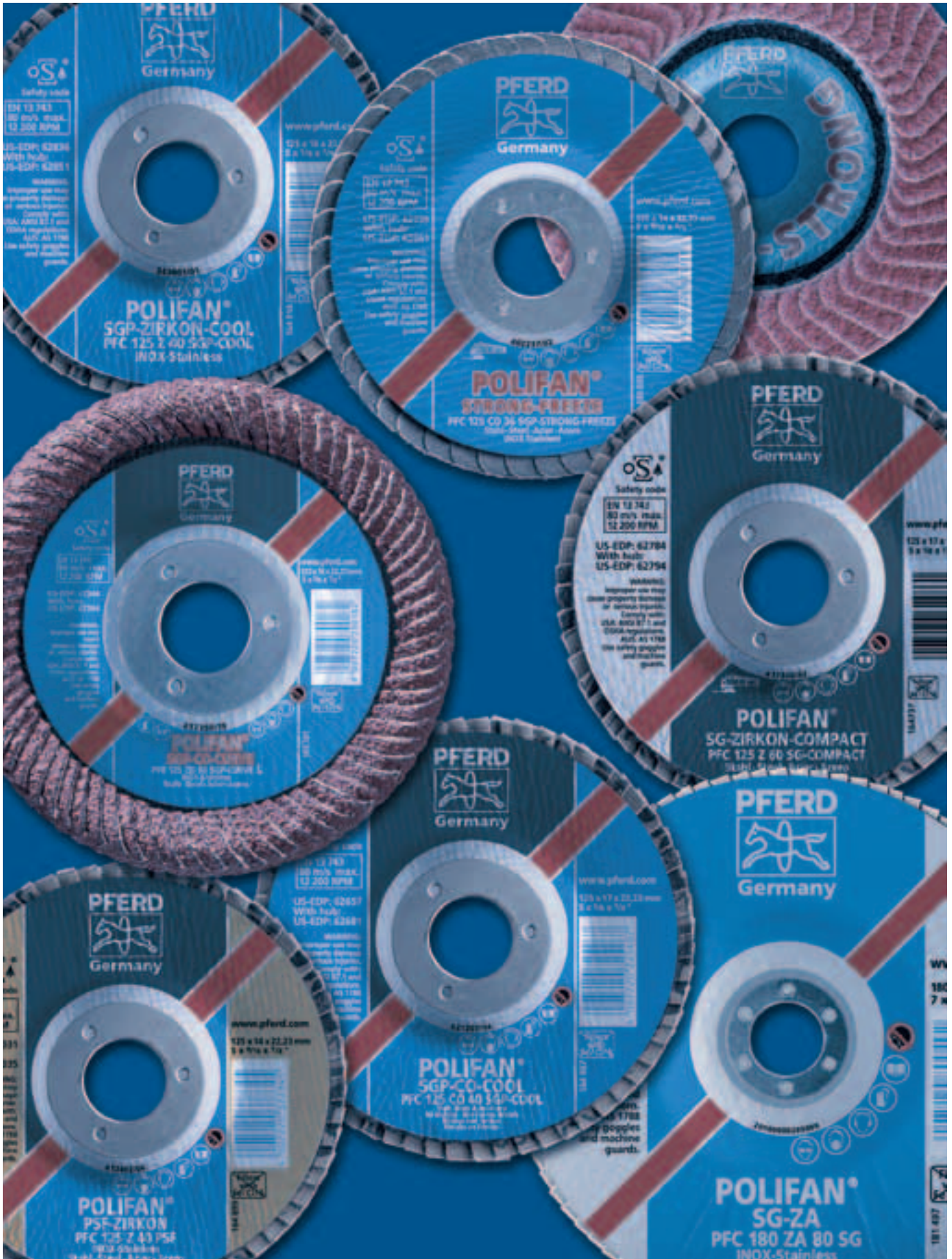

206

# POLIFAN® flap discs

The fast way to the best tool



POLIFAN® flap discs can offer advantages over reinforced grinding wheels in applications when a high surface quality must be achieved in addition to high stock removal.

The flap disc **POLIFAN®-STRONG** with its exceptional aggressiveness and tool life and the flap disc **POLIFAN®-CURVE** for fillet welds are the latest innovations from PFERD.

Special versions for customer-specific applications can be produced and supplied to order.

**PFERDERGONOMICS®** recommends flap discs to sustainably reduce vibrations, noise and dust levels generated during use.



## Product lines

For the many different grinding tasks in industry and crafts, PFERD offers POLIFAN® flap discs in three product lines with diverse special features:

Universal Line PSF	Performance Line SG	Special Line SGP
 <p>For general use in industry and crafts</p>	 <p>Widest range of tools for professional use in industry and crafts</p>	 <p>For special tasks in the industry</p>

## The fast way to the best tool

Starting with the application ❶ and material ❷, the overview shows the various types of tools in the PFERD range and helps you to find the best tool. For information on tool drives, please refer to the respective catalogue page.

❶ Application	❷ Material		Stainless steel (INOX)		Aluminium, non-ferrous metals		Plastics, other materials	
	Steel		Type	Page	Type	Page	Type	Page
Surface grinding	<b>PSF</b>		<b>PSF</b>				<b>PSF</b>	
	PSF A	32	PSF A	32			PSF A	32
	PSF ZIRKON	33	PSF ZIRKON	33				
	<b>SG</b>		<b>SG</b>		<b>SG</b>		<b>SG</b>	
	SG A	34	SG A	34	SG A-COOL	37	SG A	34
	SG ZIRKON	35	SG ZA	36	<b>SGP</b>		SG A-COOL	37
	SG ZIRKON-COMPACT	36	SG A-COOL	37	SGP CO-COOL	39	SG A-COOL	37
	<b>SGP</b>		<b>SGP</b>					
	SGP CO-STRONG	40	SGP ZIRKON-COOL	38				
			SGP CO-COOL	39				
			SGP CO-STRONG-FREEZE	41				
	<b>PSF</b>		<b>PSF</b>					
Work on weld seams	PSF A	32	PSF ZIRKON	33				
	PSF ZIRKON	33			<b>SG</b>			
	<b>SG</b>		<b>SG</b>		SG A-COOL	37		
	SG A	34	SG ZA	36	<b>SGP</b>			
	SG ZIRKON	35	SG A-COOL	37	SGP CO-COOL	39		
	SG ZIRKON-COMPACT	36	<b>SGP</b>					
	<b>SGP</b>		SGP ZIRKON-COOL	38				
	SGP ZIRKON-POWER	38	SGP CO-COOL	39				
	SGP ZIRKON-STRONG	40	SGP CO-STRONG-FREEZE	41				
	SGP CO-STRONG	40						
Chamfering	<b>SG</b>		<b>SG</b>				<b>PSF</b>	
	SG ZIRKON	35	SG ZIRKON	35	<b>SGP</b>		PSF A	32
	SG ZIRKON-COMPACT	36	SG ZIRKON-COMPACT	36	SGP CO-COOL	39	<b>SG</b>	
	<b>SGP</b>		<b>SGP</b>				SG A	34
	SGP ZIRKON-POWER	38	SGP ZIRKON-POWER	38				
	SGP ZIRKON-STRONG	40						
Deburring	<b>SG</b>		<b>SG</b>				<b>PSF</b>	
	SG ZIRKON-COMPACT	36	SG ZIRKON-COMPACT	36	<b>SGP</b>		PSF A	32
	<b>SGP</b>		<b>SGP</b>		SGP CO-COOL	39	<b>SG</b>	
	SGP ZIRKON-POWER	38	SGP ZIRKON-POWER	38			SG A	34
	SGP ZIRKON-STRONG	40						
Fillet weld grinding	<b>SGP</b>		<b>SGP</b>					
	SGP ZIRKON-CURVE	42	SGP ZIRKON-CURVE	42	<b>SGP</b>			
	SGP ZIRKON-CORNER	43	SGP CO-CURVE	43	SGP A CURVE-ALU	43		
	SGP CO-CURVE	43	SGP ZIRKON-CORNER	43				

**PFERD description**  
PFC 125 Z 40 SG-COMPACT/22.23  
① ② ③ ④ ⑤ ⑥ ⑦

**① Description and shape of the tool**

- PFF = Flat type
- PFC = Conical type
- PFR = Radial type



**② Outer diameter**

Outer dia. D in [mm]

**③ Abrasive**

- A = Aluminium oxide
- CO = Ceramic oxide grain
- Z = Zirconia alumina
- ZA = Zirconia alumina/aluminium oxide

**④ Grit size**

**⑤ PFERD product lines**

- Universal Line PSF
- Performance Line SG
- Special Line SGP

**⑥ Tool variant**

- COMPACT = for chamfering and deburring with high aggressiveness and long tool life
- COOL = for cool grinding
- CORNER = for corners and angles
- CURVE = for fillet weld and contour grinding
- FREEZE = for very cool grinding
- POWER = for work on edges
- STRONG = for maximum aggressiveness and tool life

**⑦ Centre hole diameter**

Centre hole dia. H in [mm]

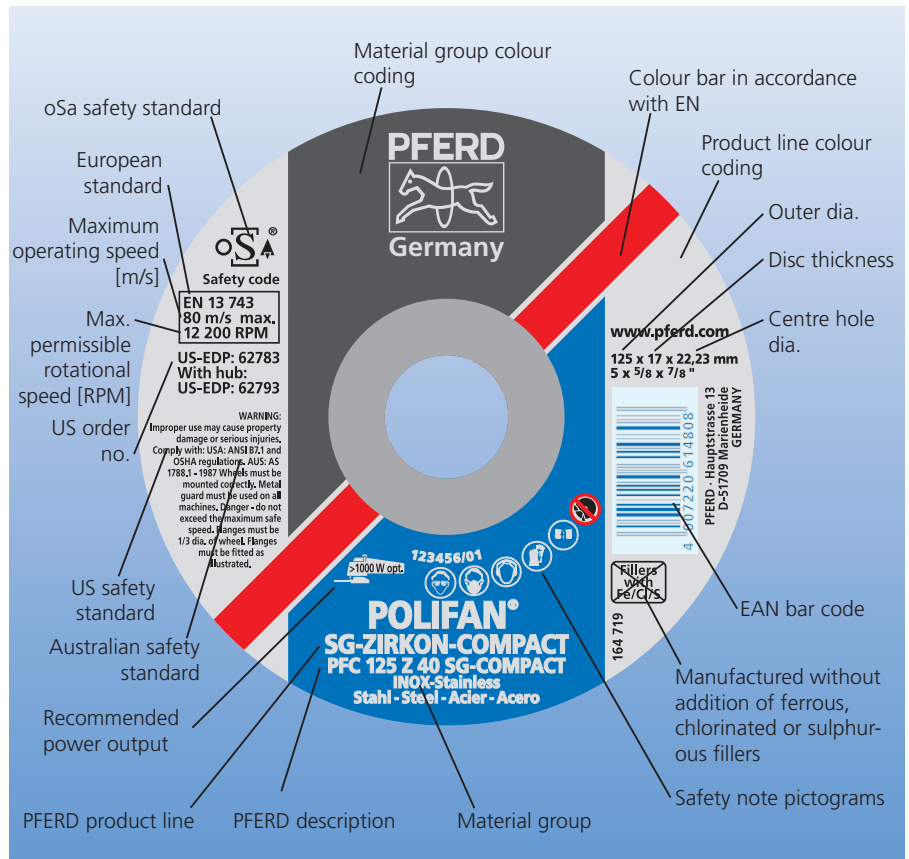

The PFERD description corresponds to the designation in accordance with EN 13743.

**Colour coding for the three product lines**

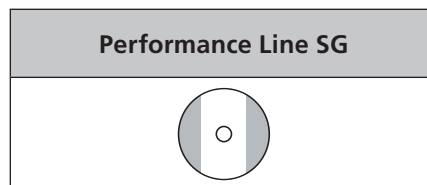
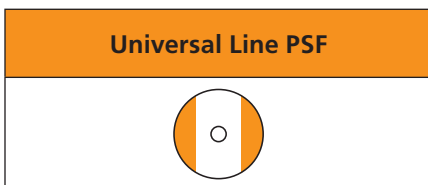

**Colour coding of the materials to be worked**

Universal Line PSF		Page
Material = Colour		
Steel/stainless steel (INOX)		32
= black/blue		33

Performance Line SG		Page
Material = Colour		
Steel/stainless steel (INOX)		34
= black/blue		35 36
Stainless steel (INOX)		36
= blue		
Aluminium/non-ferrous metals/stainless steel (INOX)		37
= silver/blue		

Special Line SGP		Page
Material = Colour		
Steel = black		40
Steel/stainless steel (INOX) = black/blue		38 42 43
Stainless steel (INOX) = blue		38 39 41
Aluminium/non-ferrous metals = silver		43



# POLIFAN® flap discs

## Universal Line PSF



Steel/INOX/plastic  
Type PSF A



Versatile tool with high stock removal performance and long tool life for multipurpose grinding work.

**Abrasive: Aluminium oxide A**  
Grit sizes: 40, 60, 80, 120

**Materials to be worked:**  
Steel, stainless steel (INOX), plastic

**Applications:**  
Surface grinding, work on weld seams

**Recommendations for use:**

- Achieves very good grinding results even at low contact pressure
- Suitable for use on angle grinders of all output categories

**PFERDERGONOMICS®:**



Description	EAN 4007220	Grit size	D x T x H [mm (inch)]	Max. perm. speed [RPM]	
<b>Flat type PFF</b>					
PFF 115 A 40 PSF/22,23	512388	40	115 x 16.0 x 22.23 (7/8)	13,300	10
PFF 115 A 60 PSF/22,23	512395	60	115 x 15.0 x 22.23 (7/8)	13,300	10
PFF 115 A 80 PSF/22,23	512401	80	115 x 15.0 x 22.23 (7/8)	13,300	10
PFF 115 A 120 PSF/22,23	512418	120	115 x 13.0 x 22.23 (7/8)	13,300	10
PFF 125 A 40 PSF/22,23	512425	40	125 x 16.0 x 22.23 (7/8)	12,200	10
PFF 125 A 60 PSF/22,23	512432	60	125 x 15.0 x 22.23 (7/8)	12,200	10
PFF 125 A 80 PSF/22,23	512449	80	125 x 15.0 x 22.23 (7/8)	12,200	10
PFF 125 A 120 PSF/22,23	512456	120	125 x 13.0 x 22.23 (7/8)	12,200	10
PFF 180 A 40 PSF/22,23	512463	40	180 x 16.0 x 22.23 (7/8)	8,500	10
<b>Conical type PFC</b>					
PFC 115 A 40 PSF/22,23	444559	40	115 x 15.0 x 22.23 (7/8)	13,300	10
PFC 115 A 60 PSF/22,23	444566	60	115 x 14.0 x 22.23 (7/8)	13,300	10
PFC 115 A 80 PSF/22,23	444573	80	115 x 14.0 x 22.23 (7/8)	13,300	10
PFC 115 A 120 PSF/22,23	444580	120	115 x 12.0 x 22.23 (7/8)	13,300	10
PFC 125 A 40 PSF/22,23	444603	40	125 x 15.0 x 22.23 (7/8)	12,200	10
PFC 125 A 60 PSF/22,23	444610	60	125 x 14.0 x 22.23 (7/8)	12,200	10
PFC 125 A 80 PSF/22,23	444627	80	125 x 14.0 x 22.23 (7/8)	12,200	10
PFC 125 A 120 PSF/22,23	444634	120	125 x 12.0 x 22.23 (7/8)	12,200	10
PFC 180 A 40 PSF/22,23	444689	40	180 x 15.0 x 22.23 (7/8)	8,500	10
PFC 180 A 60 PSF/22,23	444696	60	180 x 14.0 x 22.23 (7/8)	8,500	10



Tool with aggressive stock removal performance and long tool life for demanding multipurpose grinding work.

**Abrasive: Zirconia alumina Z**  
Grit sizes: 40, 60, 80, 120

**Materials to be worked:**  
Steel, stainless steel (INOX)

**Applications:**  
Surface grinding, work on weld seams

**Recommendations for use:**

- Optimum stock removal rates are achieved with high-powered angle grinders used at higher application pressures

**PFERDERGONOMICS®:**



Description	EAN 4007220	Grit size	D x T x H [mm (inch)]	Max. perm. speed [RPM]	
<b>Flat type PFF</b>					
PFF 115 Z 40 PSF/22,23	512487	40	115 x 15.0 x 22.23 (7/8)	13,300	10
PFF 115 Z 60 PSF/22,23	512494	60	115 x 14.0 x 22.23 (7/8)	13,300	10
PFF 115 Z 80 PSF/22,23	512500	80	115 x 14.0 x 22.23 (7/8)	13,300	10
PFF 125 Z 40 PSF/22,23	512517	40	125 x 15.0 x 22.23 (7/8)	12,200	10
PFF 125 Z 60 PSF/22,23	512524	60	125 x 14.0 x 22.23 (7/8)	12,200	10
PFF 125 Z 80 PSF/22,23	512531	80	125 x 14.0 x 22.23 (7/8)	12,200	10
PFF 180 Z 40 PSF/22,23	512548	40	180 x 15.0 x 22.23 (7/8)	8,500	10
PFF 180 Z 60 PSF/22,23	512555	60	180 x 15.0 x 22.23 (7/8)	8,500	10
<b>Conical type PFC</b>					
PFC 100 Z 40 PSF/16,0	953273	40	100 x 14.0 x 16 (5/8)	15,300	10
PFC 100 Z 60 PSF/16,0	953280	60	100 x 14.0 x 16 (5/8)	15,300	10
PFC 100 Z 80 PSF/16,0	953297	60	100 x 14.0 x 16 (5/8)	15,300	10
PFC 100 Z 120 PSF/16,0	953303	120	100 x 14.0 x 16 (5/8)	15,300	10
PFC 115 Z 40 PSF/22,23	377352	40	115 x 14.0 x 22.23 (7/8)	13,300	10
PFC 115 Z 60 PSF/22,23	444597	60	115 x 14.0 x 22.23 (7/8)	13,300	10
PFC 115 Z 80 PSF/22,23	377369	80	115 x 14.0 x 22.23 (7/8)	13,300	10
PFC 115 Z 120 PSF/22,23	934203	120	115 x 14.0 x 22.23 (7/8)	13,300	10
PFC 125 Z 40 PSF/22,23	377345	40	125 x 14.0 x 22.23 (7/8)	12,200	10
PFC 125 Z 60 PSF/22,23	444078	60	125 x 14.0 x 22.23 (7/8)	12,200	10
PFC 125 Z 80 PSF/22,23	377338	80	125 x 14.0 x 22.23 (7/8)	12,200	10
PFC 125 Z 120 PSF/22,23	934210	120	125 x 14.0 x 22.23 (7/8)	12,200	10
PFC 150 Z 40 PSF/22,23	805923	40	150 x 14.0 x 22.23 (7/8)	10,200	10
PFC 150 Z 60 PSF/22,23	805930	60	150 x 14.0 x 22.23 (7/8)	10,200	10
PFC 180 Z 40 PSF/22,23	377321	40	180 x 14.0 x 22.23 (7/8)	8,500	10
PFC 180 Z 60 PSF/22,23	444085	60	180 x 14.0 x 22.23 (7/8)	8,500	10
PFC 180 Z 80 PSF/22,23	934227	80	180 x 14.0 x 22.23 (7/8)	8,500	10
PFC 180 Z 120 PSF/22,23	934234	120	180 x 14.0 x 22.23 (7/8)	8,500	10

# POLIFAN® flap discs

## Performance Line SG



Steel/INOX/plastic  
Type SG A



Versatile professional tool for multipurpose grinding work with high stock removal performance and outstanding tool life.

**Abrasive: Aluminium oxide A**  
Grit sizes: 24, 40, 60, 80, 120

**Materials to be worked:**  
Steel, stainless steel (INOX), plastic

**Applications:**  
Surface grinding, work on weld seams

**Recommendations for use:**

- Achieves very good grinding results even at low contact pressure
- Suitable for angle grinders of all output categories

**PFERDERGONOMICS®:**



Description	EAN 4007220	Grit size	D x T x H [mm (inch)]	Max. perm. speed [RPM]	
<b>Flat type PFF</b>					
PFF 100 A 40 SG/16,0	262719	40	100 x 15.0 x 16 (5/8)	15,300	10
PFF 100 A 60 SG/16,0	262733	60	100 x 15.0 x 16 (5/8)	15,300	10
PFF 100 A 80 SG/16,0	262740	80	100 x 14.0 x 16 (5/8)	15,300	10
PFF 100 A 120 SG/16,0	262757	120	100 x 13.0 x 16 (5/8)	15,300	10
PFF 115 A 40 SG/22,23	167496	40	115 x 19.0 x 22.23 (7/8)	13,300	10
PFF 115 A 60 SG/22,23	167526	60	115 x 17.0 x 22.23 (7/8)	13,300	10
PFF 115 A 80 SG/22,23	167557	80	115 x 17.0 x 22.23 (7/8)	13,300	10
PFF 115 A 120 SG/22,23	167588	120	115 x 15.0 x 22.23 (7/8)	13,300	10
PFF 125 A 40 SG/22,23	167502	40	125 x 19.0 x 22.23 (7/8)	12,200	10
PFF 125 A 60 SG/22,23	167533	60	125 x 17.0 x 22.23 (7/8)	12,200	10
PFF 125 A 80 SG/22,23	167564	80	125 x 17.0 x 22.23 (7/8)	12,200	10
PFF 125 A 120 SG/22,23	167595	120	125 x 15.0 x 22.23 (7/8)	12,200	10
PFF 180 A 40 SG/22,23	167519	40	180 x 19.0 x 22.23 (7/8)	8,500	10
PFF 180 A 60 SG/22,23	167540	60	180 x 17.0 x 22.23 (7/8)	8,500	10
PFF 180 A 80 SG/22,23	167571	80	180 x 17.0 x 22.23 (7/8)	8,500	10
PFF 180 A 120 SG/22,23	167601	120	180 x 15.0 x 22.23 (7/8)	8,500	10
<b>Conical type PFC</b>					
PFC 115 A 24 SG/22,23	614969	24	115 x 17.0 x 22.23 (7/8)	13,300	10
PFC 115 A 40 SG/22,23	167809	40	115 x 17.0 x 22.23 (7/8)	13,300	10
PFC 115 A 60 SG/22,23	167830	60	115 x 17.0 x 22.23 (7/8)	13,300	10
PFC 115 A 80 SG/22,23	167861	80	115 x 17.0 x 22.23 (7/8)	13,300	10
PFC 115 A 120 SG/22,23	167892	120	115 x 15.0 x 22.23 (7/8)	13,300	10
PFC 125 A 24 SG/22,23	614976	24	125 x 17.0 x 22.23 (7/8)	12,200	10
PFC 125 A 40 SG/22,23	167816	40	125 x 17.0 x 22.23 (7/8)	12,200	10
PFC 125 A 60 SG/22,23	167847	60	125 x 17.0 x 22.23 (7/8)	12,200	10
PFC 125 A 80 SG/22,23	167878	80	125 x 17.0 x 22.23 (7/8)	12,200	10
PFC 125 A 120 SG/22,23	167908	120	125 x 15.0 x 22.23 (7/8)	12,200	10
PFC 180 A 24 SG/22,23	167793	24	180 x 19.0 x 22.23 (7/8)	8,500	10
PFC 180 A 40 SG/22,23	167823	40	180 x 17.0 x 22.23 (7/8)	8,500	10
PFC 180 A 60 SG/22,23	167854	60	180 x 17.0 x 22.23 (7/8)	8,500	10
PFC 180 A 80 SG/22,23	167885	80	180 x 17.0 x 22.23 (7/8)	8,500	10
PFC 180 A 120 SG/22,23	167915	120	180 x 15.0 x 22.23 (7/8)	8,500	10



High-performance tool with aggressive stock removal performance and a very long tool life. For demanding grinding work at maximum cost efficiency.

**Abrasive: Zirconia alumina Z**

Grit sizes: 40, 60, 80, 120

**Materials to be worked:**

Steel, stainless steel (INOX)

**Applications:**

Work on weld seams, chamfering, surface grinding on steel

**Recommendations for use:**

- Zirconia alumina is a high-performance abrasive delivering optimum stock removal performance on high-powered angle grinders at higher contact pressures

**PFERDERGONOMICS®:**



**Steel/INOX  
Type SG ZIRKON**

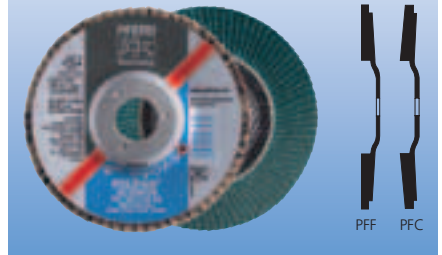

Description	EAN 4007220	Grit size	D x T x H [mm (inch)]	Max. perm. speed [RPM]	
<b>Flat type PFF</b>					
PFF 115 Z 40 SG/22,23	167618	40	115 x 18.0 x 22.23 (7/8)	13,300	10
PFF 115 Z 60 SG/22,23	167649	60	115 x 18.0 x 22.23 (7/8)	13,300	10
PFF 125 Z 40 SG/22,23	167625	40	125 x 18.0 x 22.23 (7/8)	12,200	10
PFF 125 Z 60 SG/22,23	167656	60	125 x 18.0 x 22.23 (7/8)	12,200	10
PFF 180 Z 40 SG/22,23	167632	40	180 x 20.0 x 22.23 (7/8)	8,500	10
PFF 180 Z 60 SG/22,23	167663	60	180 x 18.0 x 22.23 (7/8)	8,500	10
<b>Conical type PFC</b>					
PFC 115 Z 40 SG/22,23	167922	40	115 x 17.0 x 22.23 (7/8)	13,300	10
PFC 115 Z 60 SG/22,23	167953	60	115 x 17.0 x 22.23 (7/8)	13,300	10
PFC 115 Z 80 SG/22,23	934241	80	115 x 17.0 x 22.23 (7/8)	13,300	10
PFC 115 Z 120 SG/22,23	934258	120	115 x 17.0 x 22.23 (7/8)	13,300	10
PFC 125 Z 40 SG/22,23	167939	40	125 x 17.0 x 22.23 (7/8)	12,200	10
PFC 125 Z 60 SG/22,23	167960	60	125 x 17.0 x 22.23 (7/8)	12,200	10
PFC 125 Z 80 SG/22,23	934265	80	125 x 17.0 x 22.23 (7/8)	12,200	10
PFC 125 Z 120 SG/22,23	934272	120	125 x 17.0 x 22.23 (7/8)	12,200	10
PFC 180 Z 40 SG/22,23	167946	40	180 x 20.0 x 22.23 (7/8)	8,500	10
PFC 180 Z 60 SG/22,23	167977	60	180 x 17.0 x 22.23 (7/8)	8,500	10
PFC 180 Z 80 SG/22,23	934289	80	180 x 17.0 x 22.23 (7/8)	8,500	10
PFC 180 Z 120 SG/22,23	934296	120	180 x 17.0 x 22.23 (7/8)	8,500	10



# POLIFAN® flap discs

## Performance Line SG



### Steel/INOX Type SG ZIRKON-COMPACT



High-performance tool with very high stock removal performance and outstanding tool life. For demanding grinding work at maximum cost efficiency.

#### Abrasive: Zirconia alumina Z

Grit sizes: 40, 60

#### Materials to be worked:

Steel, stainless steel (INOX)

#### Applications:

Work on weld seams, chamfering, deburring, surface grinding on steel

#### Recommendations for use:

- Zirconia alumina is a high-performance abrasive delivering optimum stock removal performance on high-powered angle grinders

#### PFERDERGONOMICS®:



#### Description

EAN  
4007220

#### Grit size

D x T x H  
[mm (inch)]

Max. perm.  
speed  
[RPM]



#### Conical type PFC

PFC 115 Z 40 SG-COMPACT/22,23	614785	40	115 x 17.0 x 22.23 (7/8)	13,300	10
PFC 115 Z 60 SG-COMPACT/22,23	614846	60	115 x 17.0 x 22.23 (7/8)	13,300	10
PFC 125 Z 40 SG-COMPACT/22,23	614808	40	125 x 17.0 x 22.23 (7/8)	12,200	10
PFC 125 Z 60 SG-COMPACT/22,23	614860	60	125 x 17.0 x 22.23 (7/8)	12,200	10
PFC 150 Z 40 SG-COMPACT/22,23	953310	40	150 x 18.0 x 22.23 (7/8)	10,200	10
PFC 150 Z 60 SG-COMPACT/22,23	953327	60	150 x 18.0 x 22.23 (7/8)	10,200	10
PFC 180 Z 40 SG-COMPACT/22,23	614822	40	180 x 19.0 x 22.23 (7/8)	8,500	10
PFC 180 Z 60 SG-COMPACT/22,23	614891	60	180 x 19.0 x 22.23 (7/8)	8,500	10

### INOX Type SG ZA



Professional tool for demanding grinding work with high stock removal performance and long tool life.

#### Abrasive: Zirconia alumina/aluminium oxide ZA

Grit sizes: 40, 60, 80

#### Materials to be worked:

Stainless steel (INOX)

#### Applications:

Surface grinding, work on weld seams

#### Recommendations for use:

- The high-performance abrasive zirconia alumina retains its good cutting qualities in particular during surface grinding on stainless steel (INOX) and does not glaze
- Can be used on angle grinders of all output categories

#### PFERDERGONOMICS®:



#### Description

EAN  
4007220

#### Grit size

D x T x H  
[mm (inch)]

Max. perm.  
speed  
[RPM]



#### Flat type PFF

PFF 115 ZA 40 SG/22,23	800300	40	115 x 18.0 x 22.23 (7/8)	13,300	10
PFF 115 ZA 60 SG/22,23	800317	60	115 x 17.0 x 22.23 (7/8)	13,300	10
PFF 115 ZA 80 SG/22,23	800324	80	115 x 16.0 x 22.23 (7/8)	13,300	10
PFF 125 ZA 40 SG/22,23	800331	40	125 x 18.0 x 22.23 (7/8)	12,200	10
PFF 125 ZA 60 SG/22,23	800348	60	125 x 17.0 x 22.23 (7/8)	12,200	10
PFF 125 ZA 80 SG/22,23	800355	80	125 x 17.0 x 22.23 (7/8)	12,200	10

#### Conical type PFC

PFC 115 ZA 40 SG/22,23	800409	40	115 x 17.0 x 22.23 (7/8)	13,300	10
PFC 115 ZA 60 SG/22,23	800416	60	115 x 17.0 x 22.23 (7/8)	13,300	10
PFC 115 ZA 80 SG/22,23	800423	80	115 x 16.0 x 22.23 (7/8)	13,300	10
PFC 125 ZA 40 SG/22,23	800430	40	125 x 17.0 x 22.23 (7/8)	12,200	10
PFC 125 ZA 60 SG/22,23	800447	60	125 x 17.0 x 22.23 (7/8)	12,200	10
PFC 125 ZA 80 SG/22,23	800454	80	125 x 16.0 x 22.23 (7/8)	12,200	10
PFC 180 ZA 40 SG/22,23	800478	40	180 x 17.0 x 22.23 (7/8)	8,500	10
PFC 180 ZA 60 SG/22,23	800485	60	180 x 17.0 x 22.23 (7/8)	8,500	10

Professional tool for grinding work achieving a high surface quality with low thermal loads. Particularly low heat build-up grinding on materials which do not conduct heat well.

**Abrasive: Aluminium oxide A with coating**

Grit sizes: 40, 60, 80, 120

**Materials to be worked:**

Stainless steel (INOX), aluminium (grit sizes 40 and 60), non-ferrous metals

**Applications:**

Cool surface grinding, work on weld seams

**Recommendations for use:**

- Ensures low build-up of heat in the workpiece even when used with minimum contact pressure on variable-speed angle grinders at low rotational speeds
- Performs exceptionally well on sheet metal and thin profiles

**PFERDERGONOMICS®:**

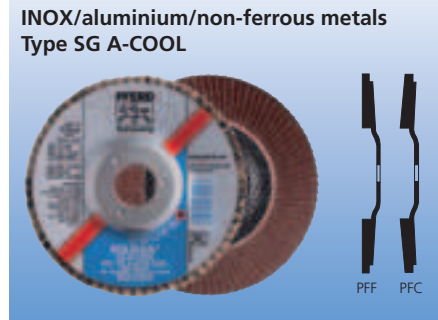

Description	EAN 4007220	Grit size	D x T x H [mm (inch)]	Max. perm. speed [RPM]	
<b>Flat type PFF</b>					
PFF 100 A 40 SG-COOL/16,0	262764	40	100 x 15.0 x 16 (5/8)	15,300	10
PFF 100 A 60 SG-COOL/16,0	262771	60	100 x 14.0 x 16 (5/8)	15,300	10
PFF 100 A 80 SG-COOL/16,0	262788	80	100 x 14.0 x 16 (5/8)	15,300	10
PFF 100 A 120 SG-COOL/16,0	934678	120	100 x 14.0 x 16 (5/8)	15,300	10
PFF 115 A 40 SG-COOL/22,23	222737	40	115 x 18.0 x 22.23 (7/8)	13,300	10
PFF 115 A 60 SG-COOL/22,23	222744	60	115 x 17.0 x 22.23 (7/8)	13,300	10
PFF 115 A 80 SG-COOL/22,23	222751	80	115 x 17.0 x 22.23 (7/8)	13,300	10
PFF 115 A 120 SG-COOL/22,23	934685	120	115 x 17.0 x 22.23 (7/8)	13,300	10
PFF 125 A 40 SG-COOL/22,23	232910	40	125 x 18.0 x 22.23 (7/8)	12,200	10
PFF 125 A 60 SG-COOL/22,23	232934	60	125 x 17.0 x 22.23 (7/8)	12,200	10
PFF 125 A 80 SG-COOL/22,23	232958	80	125 x 17.0 x 22.23 (7/8)	12,200	10
PFF 125 A 120 SG-COOL/22,23	934692	120	125 x 17.0 x 22.23 (7/8)	12,200	10
PFF 180 A 40 SG-COOL/22,23	222768	40	180 x 18.0 x 22.23 (7/8)	8,500	10
PFF 180 A 60 SG-COOL/22,23	232989	60	180 x 17.0 x 22.23 (7/8)	8,500	10
PFF 180 A 80 SG-COOL/22,23	233009	80	180 x 17.0 x 22.23 (7/8)	8,500	10
PFF 180 A 120 SG-COOL/22,23	934708	120	180 x 17.0 x 22.23 (7/8)	8,500	10
<b>Conical type PFC</b>					
PFC 115 A 40 SG-COOL/22,23	232880	40	115 x 17.0 x 22.23 (7/8)	13,300	10
PFC 115 A 60 SG-COOL/22,23	232897	60	115 x 16.0 x 22.23 (7/8)	13,300	10
PFC 115 A 80 SG-COOL/22,23	232903	80	115 x 16.0 x 22.23 (7/8)	13,300	10
PFC 115 A 120 SG-COOL/22,23	934647	120	115 x 16.0 x 22.23 (7/8)	13,300	10
PFC 125 A 40 SG-COOL/22,23	232927	40	125 x 17.0 x 22.23 (7/8)	12,200	10
PFC 125 A 60 SG-COOL/22,23	232941	60	125 x 16.0 x 22.23 (7/8)	12,200	10
PFC 125 A 80 SG-COOL/22,23	232965	80	125 x 16.0 x 22.23 (7/8)	12,200	10
PFC 125 A 120 SG-COOL/22,23	934654	120	125 x 16.0 x 22.23 (7/8)	12,200	10
PFC 180 A 40 SG-COOL/22,23	232972	40	180 x 17.0 x 22.23 (7/8)	8,500	10
PFC 180 A 60 SG-COOL/22,23	232996	60	180 x 16.0 x 22.23 (7/8)	8,500	10
PFC 180 A 80 SG-COOL/22,23	233016	80	180 x 16.0 x 22.23 (7/8)	8,500	10
PFC 180 A 120 SG-COOL/22,23	934661	120	180 x 16.0 x 22.23 (7/8)	8,500	10



# POLIFAN® flap discs

## Special Line SGP



### Steel/INOX Type SGP ZIRKON-POWER

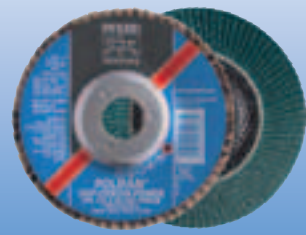

Highly resilient, aggressive special tool with long tool life and high economic value. For chamfering and deburring work with high stock removal requirements.

**Abrasive: Zirconia alumina Z**

Grit sizes: 40, 60

**Materials to be worked:**

Steel, stainless steel (INOX)

**Applications:**

Work on weld seams, chamfering, deburring

**Recommendations for use:**

- The high-performance abrasive zirconia alumina achieves its best grinding results on air turbine grinders and powerful high-frequency or electric angle grinders

**PFERDERGONOMICS®:**



Description	EAN 4007220	Grit size	D x T x H [mm (inch)]	Max. perm. speed [RPM]	
-------------	----------------	-----------	--------------------------	---------------------------	--

**Conical type PFC**

PFC 115 Z 40 SGP-POWER/22,23	618578	40	115 x 17.0 x 22.23 (7/8)	13,300	10
PFC 115 Z 60 SGP-POWER/22,23	758717	60	115 x 17.0 x 22.23 (7/8)	13,300	10
PFC 125 Z 40 SGP-POWER/22,23	614631	40	125 x 17.0 x 22.23 (7/8)	12,200	10
PFC 125 Z 60 SGP-POWER/22,23	758724	60	125 x 17.0 x 22.23 (7/8)	12,200	10
PFC 180 Z 40 SGP-POWER/22,23	618585	40	180 x 19.0 x 22.23 (7/8)	8,500	10

### INOX Type SGP ZIRKON-COOL

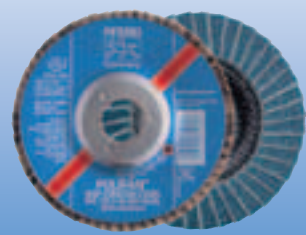

Special tool with particularly low heat generation, aggressive stock removal performance and high economic value.

For demanding grinding work with minimum thermal loads.

**Abrasive: Zirconia alumina Z with patented COOL FLAP® flaps**

Grit sizes: 40, 60, 80

**Materials to be worked:**

Stainless steel (INOX), materials which do not conduct heat well

**Applications:**

Surface grinding, work on weld seams

**Recommendations for use:**

- The combination of abrasive and COOL FLAP® flaps provides optimum grinding results without heat discoloration
- Achieves best results on high-powered angle grinders

**PFERDERGONOMICS®:**



Description	EAN 4007220	Grit size	D x T x H [mm (inch)]	Max. perm. speed [RPM]	
-------------	----------------	-----------	--------------------------	---------------------------	--

**Flat type PFF**

PFF 115 Z 40 SGP-COOL/22,23	611838	40	115 x 18.0 x 22.23 (7/8)	13,300	10
PFF 115 Z 60 SGP-COOL/22,23	611845	60	115 x 18.0 x 22.23 (7/8)	13,300	10
PFF 115 Z 80 SGP-COOL/22,23	611852	80	115 x 18.0 x 22.23 (7/8)	13,300	10
PFF 125 Z 40 SGP-COOL/22,23	611869	40	125 x 18.0 x 22.23 (7/8)	12,200	10
PFF 125 Z 60 SGP-COOL/22,23	611876	60	125 x 18.0 x 22.23 (7/8)	12,200	10
PFF 125 Z 80 SGP-COOL/22,23	611883	80	125 x 18.0 x 22.23 (7/8)	12,200	10

**Conical type PFC**

PFC 115 Z 40 SGP-COOL/22,23	611777	40	115 x 16.0 x 22.23 (7/8)	13,300	10
PFC 115 Z 60 SGP-COOL/22,23	611784	60	115 x 16.0 x 22.23 (7/8)	13,300	10
PFC 115 Z 80 SGP-COOL/22,23	611791	80	115 x 16.0 x 22.23 (7/8)	13,300	10
PFC 125 Z 40 SGP-COOL/22,23	611807	40	125 x 16.0 x 22.23 (7/8)	12,200	10
PFC 125 Z 60 SGP-COOL/22,23	611814	60	125 x 16.0 x 22.23 (7/8)	12,200	10
PFC 125 Z 80 SGP-COOL/22,23	611821	80	125 x 16.0 x 22.23 (7/8)	12,200	10

Special tool for particularly low heat generation, very aggressive stock removal performance and high economic value. For demanding grinding work on materials which are very hard to machine.

**Abrasive: Ceramic oxide grain CO with coating**  
Grit sizes: 40, 60

**Materials to be worked:**  
High-alloy and rust-resistant steel, nickel-based alloys, titanium alloys, steel

**Applications:**  
Surface grinding, work on weld seams, chamfering, deburring

**Recommendations for use:**

- The self-sharpening action of the ceramic oxide grain is effective even at low contact pressures, giving optimum grinding results without heat discolouration of the work-piece
- This product is also suitable for use on hard mill scale
- Achieves best results on high-powered angle grinders

**PFERDERGONOMICS®:**

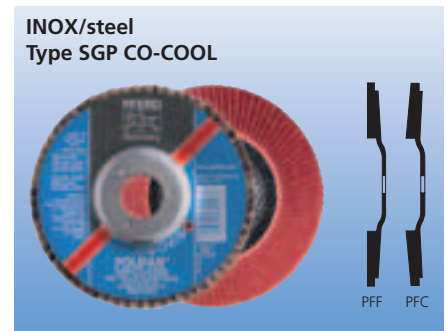

Description	EAN 4007220	Grit size	D x T x H [mm (inch)]	Max. perm. speed [RPM]	
<b>Flat type PFF</b>					
PFF 115 CO 40 SGP-COOL/22,23	725436	40	115 x 18.0 x 22.23 (7/8)	13,300	10
PFF 115 CO 60 SGP-COOL/22,23	793145	60	115 x 17.0 x 22.23 (7/8)	13,300	10
PFF 125 CO 40 SGP-COOL/22,23	725450	40	125 x 18.0 x 22.23 (7/8)	12,200	10
PFF 125 CO 60 SGP-COOL/22,23	793152	60	125 x 17.0 x 22.23 (7/8)	12,200	10
PFF 180 CO 40 SGP-COOL/22,23	725474	40	180 x 20.0 x 22.23 (7/8)	8,500	10
<b>Conical type PFC</b>					
PFC 115 CO 40 SGP-COOL/22,23	725443	40	115 x 17.0 x 22.23 (7/8)	13,300	10
PFC 115 CO 60 SGP-COOL/22,23	793169	60	115 x 16.0 x 22.23 (7/8)	13,300	10
PFC 125 CO 40 SGP-COOL/22,23	725467	40	125 x 17.0 x 22.23 (7/8)	12,200	10
PFC 125 CO 60 SGP-COOL/22,23	793176	60	125 x 16.0 x 22.23 (7/8)	12,200	10
PFC 180 CO 40 SGP-COOL/22,23	725481	40	180 x 20.0 x 22.23 (7/8)	8,500	10

Special accessory for cleaning clogged abrasive tools. Powerful cleaning action on coated abrasives.

**Recommendations for use:**

- For cleaning clogged fibre discs, POLIFAN® flap discs and abrasive belts
- Cleaning stick is held against the rotating tool

## Cleaning stick ABRACLEAN

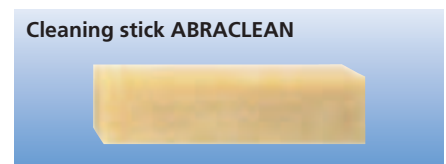

Description	EAN 4007220	Dimensions [mm]	
RG 300 50	165225	300 x 50 x 50.0	2

# POLIFAN® flap discs

## Special Line SGP



### POLIFAN®-STRONG

The patented design of the flap disc POLIFAN®-STRONG, with its long, compactly arranged flaps, introduces a whole new dimension in grinding.

#### Advantages:

- Fast grinding through constant grinding aggressiveness to the last abrasive grit
- Highest economic value through greater performance per time unit, less wear on the disc and reduced set-up times
- The greatest possible stock removal
- Extremely long tool life

#### Recommendations for use:

- Grit sizes 36/40 ideal for high stock removal, such as when working on weld seams
- Grit size 50 ideal for work on edges, such as chamfering, or for attaining fine surfaces
- Suitable for angle grinders of all output categories

PFERDERGONOMICS® recommends the flap disc POLIFAN®-STRONG to sustainably reduce vibration, noise and dust levels generated during use.



#### PFERDVIDEO

You will receive more information here or at [www.pferd.com](http://www.pferd.com)

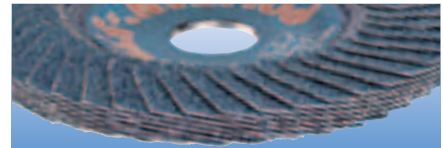

#### Steel Type SGP ZIRKON-STRONG

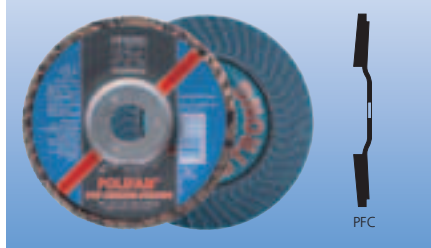

The SGP ZIRKON-STRONG is a high-performance tool with particularly high machining performance and maximum stock removal rates for demanding grinding work.

#### Abrasive: Zirconia alumina Z

Grit sizes: 36, 50

#### Materials to be worked:

Steel

#### Applications:

Work on weld seams, chamfering, deburring



#### PFERDERGONOMICS®:



Description	EAN 4007220	Grit size	D x T x H [mm (inch)]	Max. perm. speed [RPM]	
<b>Conical type PFC</b>					
PFC 115 Z 36 SGP-STRONG/22,23	777862	36	115 x 18.0 x 22.23 (7/8)	13,300	10
PFC 115 Z 50 SGP-STRONG/22,23	777879	50	115 x 18.0 x 22.23 (7/8)	13,300	10
PFC 125 Z 36 SGP-STRONG/22,23	777886	36	125 x 18.0 x 22.23 (7/8)	12,200	10
PFC 125 Z 50 SGP-STRONG/22,23	777893	50	125 x 18.0 x 22.23 (7/8)	12,200	10
PFC 180 Z 36 SGP-STRONG/22,23	827468	36	180 x 18.0 x 22.23 (7/8)	8,600	10
PFC 180 Z 50 SGP-STRONG/22,23	827482	50	180 x 18.0 x 22.23 (7/8)	8,600	10

#### Steel Type SGP CO-STRONG



The SGP CO-STRONG is a high-performance tool with particularly high machining performance for demanding grinding work.

The ceramic oxide grain provides maximum stock removal rates and outstanding tool life on steel.

#### Abrasive: Ceramic oxide grain CO

Grit size: 40

#### Materials to be worked:

Steel

#### Applications:

Surface grinding, work on weld seams

#### Recommendations for use:

- Achieves its best grinding results on air turbine grinders and high-frequency or electric angle grinders

#### PFERDERGONOMICS®:



Description	EAN 4007220	Grit size	D x T x H [mm (inch)]	Max. perm. speed [RPM]	
<b>Conical type PFC</b>					
PFC 125 CO 40 SGP-STRONG/22,23	957134	40	125 x 18.0 x 22.23 (7/8)	12,200	10
PFC 180 CO 40 SGP-STRONG/22,23	953334	40	180 x 18.0 x 22.23 (7/8)	8,600	10



### POLIFAN®-STRONG-FREEZE

With the innovative POLIFAN®-STRONG-FREEZE, PFERD offers a flap disc with worldwide unparalleled cool grinding. This is particularly beneficial for work on materials which do not conduct heat well, such as stainless steel (INOX).

The usual sparks are reduced to a minimum due to the novel structure of the abrasive. Damage to stainless steel workpieces by hot flying sparks is thus almost impossible.

**Note:**

Even during first use of the POLIFAN®-STRONG-FREEZE, the flaps exhibit an exceptional wear pattern after just a few seconds. The highly effective fillers form a shiny cooling film on the flaps (no "vitrification"). This provides the basis for unprecedented cooling, aggressiveness, and tool life.

The shape and colour of the chips generated with the POLIFAN®-STRONG-FREEZE attest to the extremely low temperatures during the grinding process.

PFERDERGONOMICS® recommends the flap disc POLIFAN®-STRONG-FREEZE to sustainably reduce vibration, noise and dust levels generated during use.



**PFERDVIDEO**

You will receive more information here or at [www.pferd.com](http://www.pferd.com)

### Special features

#### Flap disc POLIFAN®-STRONG-FREEZE

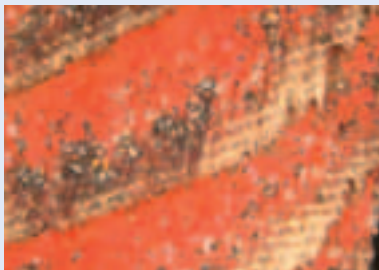

Typical wear pattern with its characteristically shiny cooling film (no "vitrification").



Long chips generated with the POLIFAN®-STRONG-FREEZE. No blue colouration due to low thermal loads.

#### Conventional flap disc

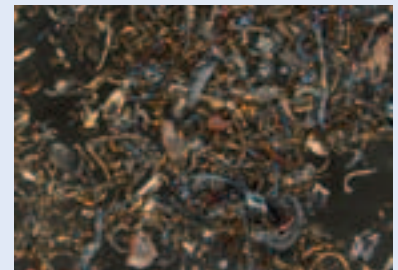

Chips produced with conventional reinforced grinding wheels or flap discs. Blue colouration due to overheating.

The SGP CO-STRONG-FREEZE is a high-performance tool with maximum stock removal and outstanding tool life for demanding grinding tasks.

The innovative abrasive with ceramic oxide grain guarantees ultra-cool grinding on materials which do not conduct heat well.

**Abrasive: Ceramic oxide grain CO**

Grit sizes: 36, 50

**Materials to be worked:**

Stainless steel (INOX), materials which do not conduct heat well, nickel- and cobalt-based alloys (aircraft engine and turbine construction), titanium, Inconel®, Hastelloy®

**Applications:**

Surface grinding, work on weld seams

**Recommendations for use:**

- Achieves best results with high-powered angle grinders

**PFERDERGONOMICS®:**



**INOX Type SGP CO-STRONG-FREEZE**



Description	EAN 4007220	Grit size	D x T x H [mm (inch)]	Max. perm. speed [RPM]	
<b>Conical type PFC</b>					
PFC 115 CO 36 SGP-STRONG-FREEZE/22,23	835296	36	115 x 18.0 x 22.23 (7/8)	13,300	10
PFC 115 CO 50 SGP-STRONG-FREEZE/22,23	835302	50	115 x 18.0 x 22.23 (7/8)	13,300	10
PFC 125 CO 36 SGP-STRONG-FREEZE/22,23	835319	36	125 x 18.0 x 22.23 (7/8)	12,200	10
PFC 125 CO 50 SGP-STRONG-FREEZE/22,23	835326	50	125 x 18.0 x 22.23 (7/8)	12,200	10
PFC 180 CO 36 SGP-STRONG-FREEZE/22,23	835333	36	180 x 18.0 x 22.23 (7/8)	8,500	10
PFC 180 CO 50 SGP-STRONG-FREEZE/22,23	835340	50	180 x 18.0 x 22.23 (7/8)	8,500	10

# POLIFAN® flap discs

## Special Line SGP

### POLIFAN®-CURVE

POLIFAN®-CURVE is a PFERD innovation for work on fillet welds. The unique radial design (PFR) offers convincing results during complex and demanding work on fillet welds through the special arrangement of the abrasive flaps.

#### Advantages:

- High stock removal rates through unparalleled fast, aggressive grinding and thus significant savings in labour costs
- Precise and optimal grinding out of fillet welds
- High-quality work results through form stability

- Outstanding tool life during work on fillet welds
- Optimal utilization of the abrasives in the radius

#### Recommendations for use:

- **Type M** for fillet weld radii > 5 mm, radial width: 11 mm
- **Type L** for fillet weld radii > 8 mm, radial width: 14 mm
- Suitable for angle grinders of all output categories

PFERDERGONOMICS® recommends the flap disc POLIFAN®-CURVE to sustainably reduce vibration, noise and dust levels generated during use and to improve the working comfort.

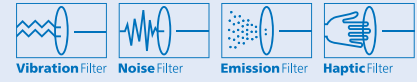

#### PFERDVIDEO

You will receive more information here or at [www.pferd.com](http://www.pferd.com)

#### PFERDERGONOMICS®:

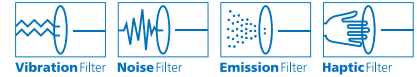

#### Steel/INOX Type SGP ZIRKON-CURVE



High-performance tool SGP ZIRKON-CURVE with particularly high stock removal rates for demanding grinding work.

**Abrasive: Zirconia alumina Z**  
Grit size: 40

**Materials to be worked:**  
Steel, stainless steel (INOX)

**Applications:**  
Fillet weld grinding, chamfering, deburring, contour grinding

Description	EAN 4007220	Grit size	Fillet weld width	D x T x H [mm (inch)]	Max. perm. speed [RPM]	
<b>Radial type PFR</b>						
PFR 115 Z 40 SGP-CURVE M/22,23	821671	40	> 5 mm	115 x 14.0 x 22.23 (7/8)	13,300	10
PFR 115 Z 40 SGP-CURVE L/22,23	821695	40	> 8 mm	115 x 16.0 x 22.23 (7/8)	13,300	10
PFR 125 Z 40 SGP-CURVE M/22,23	790151	40	> 5 mm	125 x 14.0 x 22.23 (7/8)	12,200	10
PFR 125 Z 40 SGP-CURVE L/22,23	790175	40	> 8 mm	125 x 16.0 x 22.23 (7/8)	12,200	10
PFR 150 Z 40 SGP-CURVE M/22,23	844939	40	> 5 mm	150 x 14.0 x 22.23 (7/8)	10,200	10
PFR 150 Z 40 SGP-CURVE L/22,23	844946	40	> 8 mm	150 x 16.0 x 22.23 (7/8)	10,200	10
PFR 180 Z 40 SGP-CURVE L/22,23	881248	40	> 8 mm	180 x 16.0 x 22.23 (7/8)	8,600	10



High-performance tool SGP CO-CURVE with high stock removal rates, for demanding grinding work, especially for achieving fine surface finishes.

The ceramic oxide grain guarantees extremely cool grinding on materials which do not conduct heat well, which means optimum grinding results without thermal damage to the workpiece.

**Abrasive: Ceramic oxide grain CO**  
Grit size: 60

**Materials to be worked:**  
Stainless steel (INOX), steel

**Applications:**  
Fillet weld grinding, chamfering, deburring, contour grinding

**PFERDERGONOMICS®:**

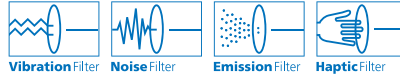

Description	EAN 4007220	Grit size	Fillet weld width	D x T x H [mm (inch)]	Max. perm. speed [RPM]	
<b>Radial type PFR</b>						
PFR 115 CO 60 SGP-CURVE M/22,23	827444	60	> 5 mm	115 x 14.0 x 22.23 (7/8)	13,300	10
PFR 115 CO 60 SGP-CURVE L/22,23	827451	60	> 8 mm	115 x 16.0 x 22.23 (7/8)	13,300	10
PFR 125 CO 60 SGP-CURVE M/22,23	790168	60	> 5 mm	125 x 14.0 x 22.23 (7/8)	12,200	10
PFR 125 CO 60 SGP-CURVE L/22,23	790182	60	> 8 mm	125 x 16.0 x 22.23 (7/8)	12,200	10

High-performance tool SGP CURVE-ALU for demanding grinding work. Particularly suitable for work on aluminium. No clogging of the tool even on soft, lubricating materials.

Contains no fillers that could leave undesirable residues on the workpiece. The surface can therefore be welded immediately.

**Abrasive: Aluminium oxide A**  
Grit size: 40

**Materials to be worked:**  
Aluminium, non-ferrous metals

**Applications:**  
Fillet weld grinding, chamfering, deburring, contour grinding

**PFERDERGONOMICS®:**

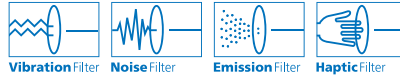

Description	EAN 4007220	Grit size	Fillet weld width	D x T x H [mm (inch)]	Max. perm. speed [RPM]	
<b>Radial type PFR</b>						
PFR 115 A 40 SGP-CURVE L/22,23	851968	40	> 8 mm	115 x 16.0 x 22.23 (7/8)	13,300	10
PFR 125 A 40 SGP-CURVE L/22,23	851975	40	> 8 mm	125 x 16.0 x 22.23 (7/8)	12,200	10

Special tool with high stock removal rates for grinding work on fillet welds and angles which are hard to reach.

**Abrasive: Zirconia alumina Z**  
Grit size: 40

**Materials to be worked:**  
Steel, stainless steel (INOX)

**Applications:**  
Work on fillet welds and angles

**Recommendations for use:**

- The projecting flaps adapt especially well to concave contours. After the projecting parts of the flaps have worn down, the tool can be used as a conventional flap disc.

**PFERDERGONOMICS®:**

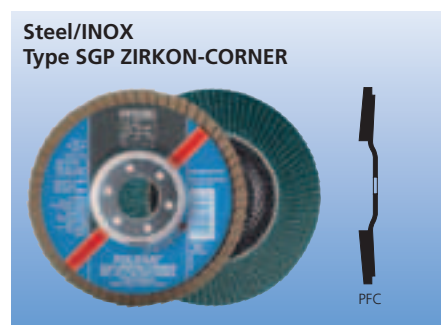

Description	EAN 4007220	Grit size	D x T x H [mm (inch)]	Max. perm. speed [RPM]	
<b>Conical type PFC</b>					
PFC 125 Z 40 SGP-CORNER/22,23	614648	40	125 x 15.0 x 22.23 (7/8)	12,200	10







### Thin cut-off wheels

In all our thin cut-off wheels product lines, PFERD has produced a noticeable performance increase for the user:

- Thinner, faster cutting with little burr formation
- Highest possible economic value
- Comfortable and safe

PFERD thin cut-off wheels are characterized by their special bond formulation.

Intensive research, development and targeted implementation in state-of-the-art production facilities guarantee our high quality and safety standards.

In addition to the high quality standards, health and safety as well as ergonomics play a prominent role at PFERD.

### PFERDERGONOMICS®

PFERDERGONOMICS® recommends the thin cut-off wheels to sustainably reduce vibration, noise and dust levels during use and to improve working comfort.

The range of extremely thin cut-off wheels (< 2 mm) made by PFERD will help to improve the working conditions of the user significantly. The tools are characterized by reduced noise values, reduced vibrations under 5 m/s<sup>2</sup> (according to ISO 5349-1+2) and less dust. Working with the exceptionally aggressive and fast PFERD cut-off wheels allows cool cutting with little burr formation and unsurpassed comfort.

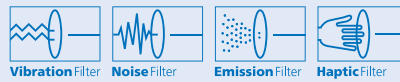

### PFERDVIDEO

You will receive more information here or at [www.pferd.com](http://www.pferd.com)



### Cut-off wheels for cordless angle grinders

Thin cut-off wheels of width 0.8 mm and 1.0 mm are ideally suitable for modern cordless angle grinders due to their narrow width, their superior cutting characteristics and optimum guidability. They guarantee more cuts per battery charge, which is why they are very economical.



### Cut-off wheels for work on stainless steel (INOX)

The importance of stainless steel (INOX) materials is continually growing due to their special material properties.

When cutting sheet metal and profiles, excessive thermal loads must be avoided to prevent thermal distortion and subsequent corrosion.

PFERD cut-off wheels for work on stainless steel (INOX) are characterized by optimum guidability. The continuous free-cutting action significantly reduces friction in the cut.

#### Advantages:

- The fastest, thinnest as well as cool cuts with little burr formation
- Longest tool life and typical PFERD safety for the lowest costs per cut
- Manufactured without addition of ferrous, chlorinated or sulphurous fillers



### Cut-off wheels for use in foundries

Cast iron, cast iron with flake graphite, cast iron with nodular graphite/nodular cast iron and similar materials are predominantly used in foundries. The removal of risers and sprues places the most stringent requirements on cut-off wheels.

In addition to high cutting characteristics and long tool life, maximum breakage resistance is a primary requirement.

PFERD cut-off wheels for foundry use meet the high requirements of speed-stable compressed-air or high-frequency angle grinders in tough grinding applications.

# Cut-off wheels

The fast way to the best tool

The wide product range of cut-off wheels offers the best solution for every application.

PFERD cut-off wheels are used where there are high demands on economic value and the quality of the work results.



## Product lines

For the many different cutting tasks in industry and crafts, PFERD offers cut-off wheels in three product lines with diverse special features:

Universal Line PS-FORTE (PSF)	Performance Line SG-ELASTIC (SG)	Special Line SG-PLUS (SGP)
 <p>For general use in industry and crafts</p>	 <p>Widest range of tools for professional use in industry and crafts</p>	 <p>For special tasks in the industry</p>

## The fast way to the best tool

Starting with the application ① and material ②, the overview shows the various types of tools in the PFERD range and helps you to find the best tool. For notes on tool drives, please refer to the respective catalogue page.

① Application	② Material	Steel		Stainless steel (INOX)		Aluminium/ non-ferrous metals		Casting scale/ cast iron		Cast iron/stone	
		Type	Page	Type	Page	Type	Page	Type	Page	Type	Page
Cutting of sheet metal and thin-walled profiles < 3 mm		<b>PS-FORTE</b> Hardness P	48	<b>PS-FORTE</b> Hardness L	49	<b>SG-ELASTIC</b> Hardness P (C) 50 <b>PS-FORTE</b> Hardness N 54		-			
		<b>SG-ELASTIC</b> Hardness S	51	Hardness P (INOX)	49						
		Hardness P	56	<b>SG-ELASTIC</b> Hardness R (INOX)	52						
		<b>SG-PLUS</b> Hardness T	60	Hardness Q (INOX)	53						
				Hardness P	56						
Cutting of solid material and profiles		<b>PS-FORTE</b> Hardness P	48	<b>PS-FORTE</b> Hardness L	49	<b>PS-FORTE</b> Hardness P (C) 50 <b>SG-ELASTIC</b> Hardness N 54 Hardness R (C) 55					
		<b>SG-ELASTIC</b> Hardness S	51, 58	Hardness P (INOX)	49						
		<b>SG-PLUS</b> Hardness T	60	<b>SG-ELASTIC</b> Hardness R (INOX)	52						
				Hardness Q (INOX)	53						
				Hardness Q (INOX-CAST)	62						
		<b>SG-PLUS</b> Hardness S (INOX)	61	Hardness Q (INOX-CAST)	62	<b>SG-ELASTIC</b> Hardness P (CAST) 62 Hardness Q (CAST) 63	<b>SG-PLUS</b> Hardness Q (CAST) 63	<b>PS-FORTE</b> Hardness P (C) 50 <b>SG-ELASTIC</b> Hardness R (C) 55, 59 Hardness Q 59			



You will find the combination abrasive DUODISC® for cutting and light deburring on page 12.

**PFERD description**  
EHT 178-1,6 A 46 Q SG-INOX/22.23  
① ② ③ ④ ⑤ ⑥ ⑦ ⑧ ⑨

**① Description and shape of the tool**

EHT = Flat type  
EH = Depressed-centre type

**② Outer diameter**

Outer dia. D in [mm]

**③ Wheel thickness**

Width T or U in [mm]

**④ Abrasive**

A = Aluminium oxide  
AC = Aluminium oxide/silicon carbide  
C = Silicon carbide  
ZA = Zirconia alumina/aluminium oxide

**⑤ Grit size according to ISO 8486**

**⑥ Hardness grade (wheel properties)**

Hardness grade	Wheel properties	Material groups
<b>Universal Line PS-FORTE (PSF)</b>		
L	soft	Stainless steel (INOX)
P	medium-hard	Steel, stainless steel (INOX), stone
<b>Performance Line SG-ELASTIC (SG)</b>		
N	soft	Aluminium, non-ferrous metals
P	medium-hard	Steel, stainless steel (INOX), cast iron, non-ferrous metals
Q	medium-hard	Stainless steel (INOX), INOX cast, cast iron
R	hard	Stainless steel (INOX), stone
S	hard	Steel
<b>Special Line SG-PLUS (SGP)</b>		
Q	medium-hard	INOX cast
S	hard	Stainless steel (INOX)
T	very hard	Steel

**⑦ PFERD product lines**

Universal Line PS-FORTE (PSF)  
Performance Line SG-ELASTIC (SG)  
Special Line SG-PLUS (SGP)

**⑧ Material group**

See also point 6

**⑨ Centre hole diameter**

Centre hole dia. H in [mm]

**Designation according to EN 12413**

41 A 46 R BF 80  
① ② ③ ④ ⑤ ⑥

**① Designation and shape of the tool**

41 = Flat cut-off wheel  
42 = Depressed-centre cut-off wheel

**② Abrasives**

A = Aluminium oxide  
C = Silicon carbide  
AC = Aluminium oxide/silicon carbide  
ZA = Zirconia alumina/aluminium oxide

**③ Grit size according to ISO 8486**

**④ Hardness (wheel properties)**

Abrasive hardness grades are classified using letters in increasing alphabetical order from the softest to hardest (A to Z).

**⑤ Bond**

BF = Fibre-reinforced resinoid bond with cloth

**⑥ Maximum operating speed in [m/s]**

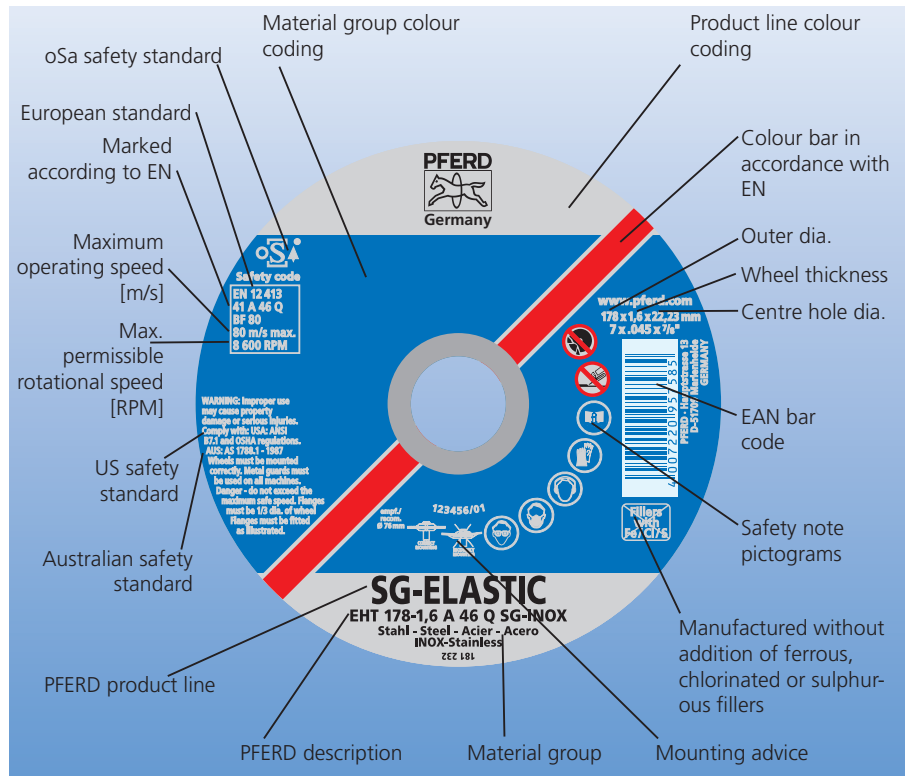

**Colour coding for the three product lines**

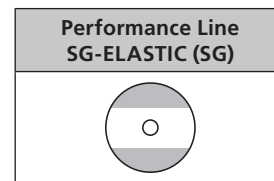
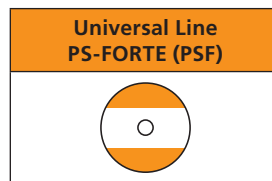

**Colour coding of the materials to be worked**

Universal Line PS-FORTE (PSF)		
Material = Colour		Page
	Steel = black	48
	Stainless steel (INOX) = blue	49
	Non-ferrous metals/aluminium/stone = silver/green	50

Performance Line SG-ELASTIC (SG)		
Material = Colour		Page
	Steel = black	51 58
	Stainless steel (INOX) = blue	52 53
	Non-ferrous metals/aluminium = silver	54
	Cast iron = red	63
	Steel/cast iron = black/red	62
	Cast INOX = blue/red	62
	Stone/cast iron = green/red	59
	Stone = green	55 59

Special Line SG-PLUS (SGP)		
Material = Colour		Page
	Steel = black	60
	Stainless steel (INOX) = blue	61
	Cast iron = red	63

# Cut-off wheels

## Universal Line PS-FORTE



Medium-hard, multipurpose tool of hardness P with high cutting performance and long tool life.

**Abrasive: Aluminium oxide A**

**Materials to be worked:**

Steel

**Applications:**

Cutting of sheet metal, profiles and solid material

**Recommendations for use:**

- Wheel thicknesses 1.9/1.6/1.0 mm for fast, easy cutting with minimized burr formation
- Wheel thickness 2.4 mm for multipurpose cutting work

- Wheel thicknesses 3.2/3.0 mm for maximum tool life and high lateral stability
- Suitable for use on angle grinders of all output categories
- Use of large clamping flanges (SFS 76, page 48) increases the lateral stability and ensures precise wheel guidance, in particular for thin cut-off wheels of the flat type with dia. 178 and 230 mm

**PFERDERGONOMICS®:**

Thin cut-off wheels < 2.0 mm:

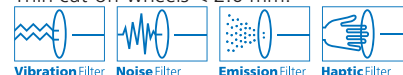

Description	EAN 4007220	EN designation	D x T/U x H [mm (inch)]	Max. perm. speed [RPM]	
<b>Flat type EHT (shape 41)</b>					
EHT 100-2,4 A 46 P PSF/16,0	321256	41 A 46 P BF 80	100 x 2.4 x 16.0 (5/8)	15,300	25
EHT 115-1,0 A 60 P PSF/22,23	560242	41 A 60 P BF 80	115 x 1.0 x 22.23 (7/8)	13,300	25
EHT 115-1,6 A 46 P PSF/22,23	538111	41 A 46 P BF 80	115 x 1.6 x 22.23 (7/8)	13,300	25
EHT 115-2,4 A 46 P PSF/22,23	669174	41 A 46 P BF 80	115 x 2.4 x 22.23 (7/8)	13,300	25
EHT 125-1,0 A 60 P PSF/22,23	560259	41 A 60 P BF 80	125 x 1.0 x 22.23 (7/8)	12,200	25
EHT 125-1,6 A 46 P PSF/22,23	538128	41 A 46 P BF 80	125 x 1.6 x 22.23 (7/8)	12,200	25
EHT 125-2,4 A 46 P PSF/22,23	669167	41 A 46 P BF 80	125 x 2.4 x 22.23 (7/8)	12,200	25
EHT 150-1,6 A 46 P PSF/22,23	953341	41 A 46 P BF 80	150 x 1.6 x 22.23 (7/8)	10,200	25
EHT 178-1,6 A 46 P PSF/22,23	581209	41 A 46 P BF 80	178 x 1.6 x 22.23 (7/8)	8,600	25
EHT 178-3,0 A 24 P PSF/22,23	163474	41 A 24 P BF 80	178 x 3.0 x 22.23 (7/8)	8,600	25
EHT 230-1,9 A 46 P PSF/22,23	581339	41 A 46 P BF 80	230 x 1.9 x 22.23 (7/8)	6,600	25
EHT 230-3,0 A 24 P PSF/22,23	163498	41 A 24 P BF 80	230 x 3.0 x 22.23 (7/8)	6,600	25
<b>Depressed-centre type EH (shape 42)</b>					
EH 100-2,4 A 46 P PSF/16,0	163511	42 A 46 P BF 80	100 x 2.4 x 16.0 (5/8)	15,300	25
EH 100-3,2 A 46 P PSF/16,0	522981	42 A 46 P BF 80	100 x 3.2 x 16.0 (5/8)	15,300	25
EH 115-2,4 A 46 P PSF/22,23	163528	42 A 46 P BF 80	115 x 2.4 x 22.23 (7/8)	13,300	25
EH 115-3,2 A 46 P PSF/22,23	522998	42 A 46 P BF 80	115 x 3.2 x 22.23 (7/8)	13,300	25
EH 125-2,4 A 46 P PSF/22,23	163429	42 A 46 P BF 80	125 x 2.4 x 22.23 (7/8)	12,200	25
EH 125-3,2 A 46 P PSF/22,23	523001	42 A 46 P BF 80	125 x 3.2 x 22.23 (7/8)	12,200	25
EH 178-3,0 A 24 P PSF/22,23	163436	42 A 24 P BF 80	178 x 3.0 x 22.23 (7/8)	8,600	25
EH 230-3,0 A 24 P PSF/22,23	163450	42 A 24 P BF 80	230 x 3.0 x 22.23 (7/8)	6,600	25

## Clamping flange

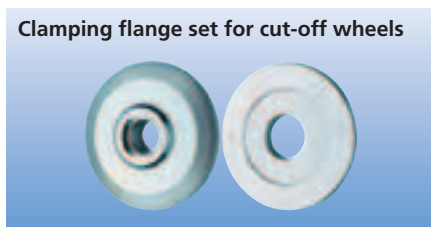

Special flange dia. 76 mm for drive spindles M14 or 5/8" of tool steel. Increases lateral stability and improves power transmission on cut-off wheels.

**Recommendations for use:**

- The use of large clamping flanges (SFS 76) increases the lateral stability and ensures accurate wheel guidance, in particular for thin cut-off wheels of the flat type with dia. 178 or 230 mm



Description	EAN 4007220	Flange dia. [mm]	
SFS 76 M14	595275	76	1
SFS 76 5/8"	895856	76	1



Medium-hard, multipurpose tool of hardness P (INOX) with high cutting performance and long tool life, for reduced heat build-up during cutting.

**Abrasive: Aluminium oxide A**

Manufactured without addition of ferrous, chlorinated and sulphurous fillers.

**Materials to be worked:**

Stainless steel (INOX)

**Applications:**

Cutting of sheet metal, profiles and solid material

**Recommendations for use:**

- Wheel thicknesses 1.9/1.6/1.0 mm for fast, easy cutting with minimized burr formation

- Wheel thicknesses 2.5/2.4 mm for multipurpose cutting work
- Wheel thickness 3.2 mm for maximum tool life and high lateral stability
- Suitable for use on angle grinders of all output categories
- The use of large clamping flanges (SFS 76, page 48) increases the lateral stability and ensures precise wheel guidance, in particular for thin cut-off wheels of the flat type with dia. 178 and 230 mm

**PFERDERGONOMICS®:**

Thin cut-off wheels < 2.0 mm:

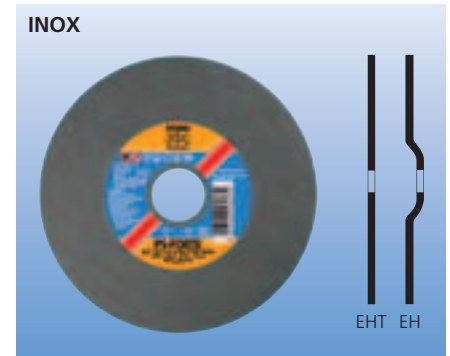
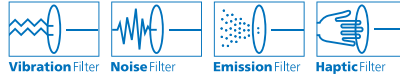

Description	EAN 4007220	EN designation	D x T/U x H [mm (inch)]	Max. perm. speed [RPM]	
<b>Flat type EHT (shape 41)</b>					
EHT 115-1,0 A 60 P PSF-INOX/22,23	560266	41 A 60 P BF 80	115 x 1.0 x 22.23 (7/8)	13,300	25
EHT 115-1,6 A 46 P PSF-INOX/22,23	538135	41 A 46 P BF 80	115 x 1.6 x 22.23 (7/8)	13,300	25
EHT 115-2,4 A 46 P PSF-INOX/22,23	523025	41 A 46 P BF 80	115 x 2.4 x 22.23 (7/8)	13,300	25
EHT 125-1,0 A 60 P PSF-INOX/22,23	560372	41 A 60 P BF 80	125 x 1.0 x 22.23 (7/8)	12,200	25
EHT 125-1,6 A 46 P PSF-INOX/22,23	538142	41 A 46 P BF 80	125 x 1.6 x 22.23 (7/8)	12,200	25
EHT 125-2,4 A 46 P PSF-INOX/22,23	523049	41 A 46 P BF 80	125 x 2.4 x 22.23 (7/8)	12,200	25
EHT 150-1,6 A 46 P PSF-INOX/22,23	581223	41 A 46 P BF 80	150 x 1.6 x 22.23 (7/8)	10,200	25
EHT 178-1,6 A 46 P PSF-INOX/22,23	581230	41 A 46 P BF 80	178 x 1.6 x 22.23 (7/8)	8,600	25
EHT 178-2,5 A 24 P PSF-INOX/22,23	523063	41 A 24 P BF 80	178 x 2.5 x 22.23 (7/8)	8,600	25
EHT 230-1,9 A 46 P PSF-INOX/22,23	581216	41 A 46 P BF 80	230 x 1.9 x 22.23 (7/8)	6,600	25
EHT 230-2,5 A 24 P PSF-INOX/22,23	523087	41 A 24 P BF 80	230 x 2.5 x 22.23 (7/8)	6,600	25
<b>Depressed-centre type EH (shape 42)</b>					
EH 100-3,2 A 46 P PSF-INOX/16,0	523018	42 A 46 P BF 80	100 x 3.2 x 16.0 (5/8)	15,300	25
EH 115-3,2 A 46 P PSF-INOX/22,23	523032	42 A 46 P BF 80	115 x 3.2 x 22.23 (7/8)	13,300	25
EH 125-3,2 A 46 P PSF-INOX/22,23	523056	42 A 46 P BF 80	125 x 3.2 x 22.23 (7/8)	12,200	25
EH 178-2,5 A 24 P PSF-INOX/22,23	523070	42 A 24 P BF 80	178 x 2.5 x 22.23 (7/8)	8,600	25
EH 230-2,5 A 24 P PSF-INOX/22,23	523094	42 A 24 P BF 80	230 x 2.5 x 22.23 (7/8)	6,600	25

Soft, multipurpose tool of hardness L with high cutting performance and long tool life, for reduced heat build-up during cutting.

**Abrasive: Aluminium oxide A**

Manufactured without addition of ferrous, chlorinated and sulphurous fillers.

**Materials to be worked:**

Stainless steel (INOX)

**Applications:**

Cutting of sheet metal, profiles and solid material

**Recommendations for use:**

- For fast, easy cutting with minimized burr formation
- Suitable for use on angle grinders of all output categories

**PFERDERGONOMICS®:**

Thin cut-off wheels < 2.0 mm:

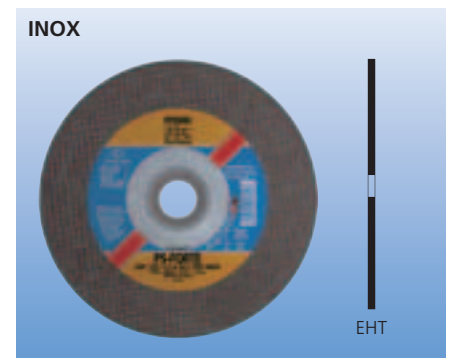
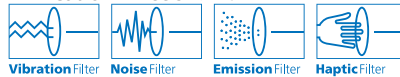

Description	EAN 4007220	EN designation	D x T/U x H [mm (inch)]	Max. perm. speed [RPM]	
<b>Flat type EHT (shape 41)</b>					
EHT 115-1,0 A 60 L PSF-INOX/22,23	957400	41 A 60 L BF 80	115 x 1.0 x 22.23 (7/8)	13,300	25
EHT 115-1,6 A 46 L PSF-INOX/22,23	957516	41 A 46 L BF 80	115 x 1.6 x 22.23 (7/8)	13,300	25
EHT 125-1,0 A 60 L PSF-INOX/22,23	957523	41 A 60 L BF 80	125 x 1.0 x 22.23 (7/8)	12,200	25
EHT 125-1,6 A 46 L PSF-INOX/22,23	957530	41 A 46 L BF 80	125 x 1.6 x 22.23 (7/8)	12,200	25

# Cut-off wheels

## Universal Line PS-FORTE



### Stone/aluminium/non-ferrous metals



Medium-hard, multipurpose tool of hardness P (C) with high cutting performance and long tool life.

**Abrasive: Silicon carbide C**

**Materials to be worked:**

Natural stone, synthetic stone, fire-resistant stone, aluminium, non-ferrous metals

**Applications:**

Cutting of solid material

**Recommendations for use:**

■ Wheel thicknesses 1.6/1.0 mm for fast, easy cutting with minimized burr formation

- Wheel thickness 2.4 mm for multipurpose cutting work
- Wheel thicknesses 3.2/3.0 mm for maximum tool life with high lateral stability
- Suitable for use on angle grinders of all output categories

**PFERDERGONOMICS®:**

Thin cut-off wheels < 2.0 mm:

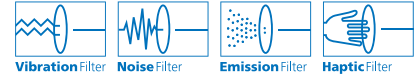

Description	EAN 4007220	EN designation	D x T/U x H [mm (inch)]	Max. perm. speed [RPM]	
<b>Flat type EHT (shape 41)</b>					
EHT 115-1,0 C 60 P PSF/22,23	669310	41 C 60 P BF 80	115 x 1.0 x 22.23 (7/8)	13,300	25
EHT 115-1,6 C 46 P PSF/22,23	669297	41 C 46 P BF 80	115 x 1.6 x 22.23 (7/8)	13,300	25
EHT 125-1,0 C 60 P PSF/22,23	804278	41 C 60 P BF 80	125 x 1.0 x 22.23 (7/8)	12,200	25
EHT 125-1,6 C 46 P PSF/22,23	804308	41 C 46 P BF 80	125 x 1.6 x 22.23 (7/8)	12,200	25
EHT 178-3,2 C 24 P PSF/22,23	163641	41 C 24 P BF 80	178 x 3.2 x 22.23 (7/8)	8,600	25
EHT 230-3,2 C 24 P PSF/22,23	163658	41 C 24 P BF 80	230 x 3.2 x 22.23 (7/8)	6,600	25
<b>Depressed-centre type EH (shape 42)</b>					
EH 100-2,4 C 30 P PSF/16,0	523124	42 C 30 P BF 80	100 x 2.4 x 16.0 (5/8)	15,300	25
EH 115-2,4 C 30 P PSF/22,23	163665	42 C 30 P BF 80	115 x 2.4 x 22.23 (7/8)	13,300	25
EH 125-2,4 C 30 P PSF/22,23	163597	42 C 30 P BF 80	125 x 2.4 x 22.23 (7/8)	12,200	25
EH 150-3,0 C 24 P PSF/22,23	523131	42 C 24 P BF 80	150 x 3.0 x 22.23 (7/8)	10,200	25
EH 178-3,2 C 24 P PSF/22,23	163603	42 C 24 P BF 80	178 x 3.2 x 22.23 (7/8)	8,600	25
EH 230-3,2 C 24 P PSF/22,23	163627	42 C 24 P BF 80	230 x 3.2 x 22.23 (7/8)	6,600	25



Hard, high-performance tool of hardness S with high cutting performance and very long tool life.

**Abrasive: Aluminium oxide A**

**Materials to be worked:**

Steel

**Applications:**

Cutting of sheet metal, profiles and solid material

**Recommendations for use:**

- Wheel thicknesses 1.9/1.6/1.0 mm for fast, easy cutting with minimized burr formation
- Wheel thickness 2.4 mm for multipurpose cutting work

- Wheel thicknesses 3.2/3.0/2.9 mm for maximum tool life with high lateral stability
- Suitable for use on angle grinders of all output categories
- The use of large clamping flanges (SFS 76, page 48) increases the lateral stability and ensures precise wheel guidance, in particular for thin cut-off wheels of the flat type with dia. 178 and 230 mm

**PFERDERGONOMICS®:**  
Thin cut-off wheels < 2.0 mm:

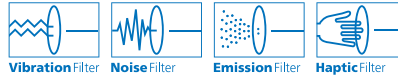

Description	EAN 4007220	EN designation	D x T/U x H [mm (inch)]	Max. perm. speed [RPM]	
<b>Flat type EHT (shape 41)</b>					
EHT 100-2,4 A 46 S SG/16,0	162590	41 A 46 S BF 80	100 x 2.4 x 16.0 (5/8)	15,300	25
EHT 105-1,0 A 60 S SG/16,0	953358	41 A 60 S BF 80	105 x 1.0 x 16.0 (5/8)	14,500	25
EHT 115-1,0 A 60 S SG/22,23	499719	41 A 60 S BF 80	115 x 1.0 x 22.23 (7/8)	13,300	25
EHT 115-1,6 A 46 S SG/22,23	522813	41 A 46 S BF 80	115 x 1.6 x 22.23 (7/8)	13,300	25
EHT 115-2,4 A 30 S SG/22,23	162637	41 A 30 S BF 80	115 x 2.4 x 22.23 (7/8)	13,300	25
EHT 125-1,0 A 60 S SG/22,23	499740	41 A 60 S BF 80	125 x 1.0 x 22.23 (7/8)	12,200	25
EHT 125-1,6 A 46 S SG/22,23	522691	41 A 46 S BF 80	125 x 1.6 x 22.23 (7/8)	12,200	25
EHT 125-2,4 A 30 S SG/22,23	162231	41 A 30 S BF 80	125 x 2.4 x 22.23 (7/8)	12,200	25
EHT 150-1,6 A 46 S SG/22,23	953365	41 A 46 S BF 80	150 x 1.6 x 22.23 (7/8)	10,200	25
EHT 150-3,0 A 24 S SG/22,23	162248	41 A 24 S BF 80	150 x 3.0 x 22.23 (7/8)	10,200	25
EHT 178-1,6 A 46 S SG/22,23	581155	41 A 46 S BF 80	178 x 1.6 x 22.23 (7/8)	8,600	25
EHT 178-2,9 A 24 S SG/22,23	522639	41 A 24 S BF 80	178 x 2.9 x 22.23 (7/8)	8,600	25
EHT 178-3,2 A 24 S SG/22,23	162347	41 A 24 S BF 80	178 x 3.2 x 22.23 (7/8)	8,600	25
EHT 230-1,9 A 46 S SG/22,23	581162	41 A 46 S BF 80	230 x 1.9 x 22.23 (7/8)	6,600	25
EHT 230-2,9 A 24 S SG/22,23	522677	41 A 24 S BF 80	230 x 2.9 x 22.23 (7/8)	6,600	25
EHT 230-3,2 A 24 S SG/22,23	162422	41 A 24 S BF 80	230 x 3.2 x 22.23 (7/8)	6,600	25
<b>Depressed-centre type EH (shape 42)</b>					
EH 100-2,4 A 46 S SG/16,0	162576	42 A 46 S BF 80	100 x 2.4 x 16.0 (5/8)	15,300	25
EH 115-2,4 A 30 S SG/22,23	162606	42 A 30 S BF 80	115 x 2.4 x 22.23 (7/8)	13,300	25
EH 115-3,2 A 30 S SG/22,23	522424	42 A 30 S BF 80	115 x 3.2 x 22.23 (7/8)	13,300	25
EH 125-2,4 A 30 S SG/22,23	162217	42 A 30 S BF 80	125 x 2.4 x 22.23 (7/8)	12,200	25
EH 125-3,2 A 30 S SG/22,23	522431	42 A 30 S BF 80	125 x 3.2 x 22.23 (7/8)	12,200	25
EH 150-3,0 A 24 S SG/22,23	162255	42 A 24 S BF 80	150 x 3.0 x 22.23 (7/8)	10,200	25
EH 178-2,9 A 24 S SG/22,23	522653	42 A 24 S BF 80	178 x 2.9 x 22.23 (7/8)	8,600	25
EH 178-3,2 A 24 S SG/22,23	162262	42 A 24 S BF 80	178 x 3.2 x 22.23 (7/8)	8,600	25
EH 230-2,9 A 24 S SG/22,23	522684	42 A 24 S BF 80	230 x 2.9 x 22.23 (7/8)	6,600	25
EH 230-3,2 A 24 S SG/22,23	162309	42 A 24 S BF 80	230 x 3.2 x 22.23 (7/8)	6,600	25



**PFERDVIDEO**

You will receive more information here or at [www.pferd.com](http://www.pferd.com)

# Cut-off wheels

## Performance Line SG-ELASTIC

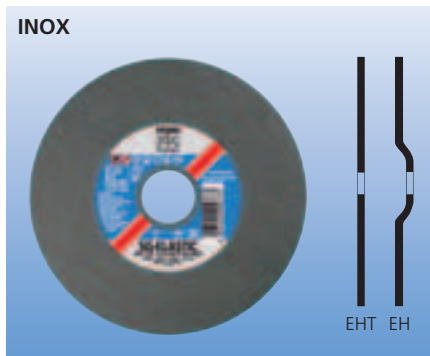

Hard, high-performance tool of hardness R (INOX) with high cutting performance and very long tool life for reduced heat build-up during cutting.

**Abrasive: Aluminium oxide A**

Manufactured without addition of ferrous, chlorinated and sulphurous fillers.

**Materials to be worked:**

Stainless steel (INOX)

**Applications:**

Cutting of sheet metal, profiles and solid material

**Recommendations for use:**

- Wheel thicknesses 1.9/1.6/1.0 mm for fast, easy cutting with minimized burr formation

- Wheel thicknesses 2.5/2.4/2.0 mm for multi-purpose cutting work
- Wheel thickness 3.2 mm for maximum tool life with high lateral stability
- Suitable for use on angle grinders of all output categories
- The use of large clamping flanges (SFS 76, page 48) increases lateral stability and ensures accurate wheel guidance, in particular for thin cut-off wheels of the flat type with dia. 178 and 230 mm

**PFERDERGONOMICS®:**

Thin cut-off wheels < 2.0 mm:

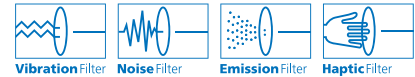

Description	EAN 4007220	EN designation	D x T/U x H [mm (inch)]	Max. perm. speed [RPM]	
<b>Flat type EHT (shape 41)</b>					
EHT 100-1,0 A 60 R SG-INOX/16,0	511787	41 A 60 R BF 80	100 x 1.0 x 16.0 (5/8)	15,300	25
EHT 105-1,0 A 60 R SG-INOX/16,0	953372	41 A 60 R BF 80	105 x 1.0 x 16.0 (5/8)	14,500	25
EHT 105-1,3 A 60 R SG-INOX/16,0	953396	41 A 60 R BF 80	105 x 1.3 x 16.0 (5/8)	14,500	25
EHT 115-1,0 A 60 R SG-INOX/22,23	499702	41 A 60 R BF 80	115 x 1.0 x 22.23 (7/8)	13,300	25
EHT 115-1,6 A 46 R SG-INOX/22,23	355442	41 A 46 R BF 80	115 x 1.6 x 22.23 (7/8)	13,300	25
EHT 115-2,0 A 46 R SG-INOX/22,23	953402	41 A 46 R BF 80	115 x 2.0 x 22.23 (7/8)	13,300	25
EHT 115-2,4 A 46 R SG-INOX/22,23	522851	41 A 46 R BF 80	115 x 2.4 x 22.23 (7/8)	13,300	25
EHT 125-1,0 A 60 R SG-INOX/22,23	499733	41 A 60 R BF 80	125 x 1.0 x 22.23 (7/8)	12,200	25
EHT 125-1,6 A 46 R SG-INOX/22,23	355459	41 A 46 R BF 80	125 x 1.6 x 22.23 (7/8)	12,200	25
EHT 125-2,0 A 46 R SG-INOX/22,23	953419	41 A 46 R BF 80	125 x 2.0 x 22.23 (7/8)	12,200	25
EHT 125-2,4 A 46 R SG-INOX/22,23	522875	41 A 46 R BF 80	125 x 2.4 x 22.23 (7/8)	12,200	25
EHT 150-1,6 A 46 R SG-INOX/22,23	581179	41 A 46 R BF 80	150 x 1.6 x 22.23 (7/8)	10,200	25
EHT 178-1,6 A 46 R SG-INOX/22,23	807729	41 A 46 R BF 80	178 x 1.6 x 22.23 (7/8)	8,600	25
EHT 178-2,5 A 24 R SG-INOX/22,23	162378	41 A 24 R BF 80	178 x 2.5 x 22.23 (7/8)	8,600	25
EHT 230-1,9 A 46 R SG-INOX/22,23	807736	41 A 46 R BF 80	230 x 1.9 x 22.23 (7/8)	6,600	25
EHT 230-2,5 A 24 R SG-INOX/22,23	162446	41 A 24 R BF 80	230 x 2.5 x 22.23 (7/8)	6,600	25
EHT 230-3,2 A 24 R SG-INOX/22,23	475690	41 A 24 R BF 80	230 x 3.2 x 22.23 (7/8)	6,600	25
<b>Depressed-centre type EH (shape 42)</b>					
EH 115-2,4 A 46 R SG-INOX/22,23	162613	42 A 46 R BF 80	115 x 2.4 x 22.23 (7/8)	13,300	25
EH 115-3,2 A 46 R SG-INOX/22,23	522868	42 A 46 R BF 80	115 x 3.2 x 22.23 (7/8)	13,300	25
EH 125-2,4 A 46 R SG-INOX/22,23	162651	42 A 46 R BF 80	125 x 2.4 x 22.23 (7/8)	12,200	25
EH 125-3,2 A 46 R SG-INOX/22,23	522882	42 A 46 R BF 80	125 x 3.2 x 22.23 (7/8)	12,200	25
EH 178-2,5 A 24 R SG-INOX/22,23	162279	42 A 24 R BF 80	178 x 2.5 x 22.23 (7/8)	8,600	25
EH 230-2,5 A 24 R SG-INOX/22,23	162316	42 A 24 R BF 80	230 x 2.5 x 22.23 (7/8)	6,600	25



**PFERDVIDEO**

You will receive more information here or at [www.pferd.com](http://www.pferd.com)



Medium-hard, high-performance tool of hardness Q (INOX) with high cutting performance and long tool life.

**Abrasives: Aluminium oxide A**

Manufactured without addition of ferrous, chlorinated and sulphurous fillers.

**Materials to be worked:**

Stainless steel (INOX)

**Applications:**

Cutting of sheet metal, profiles and solid material

**Recommendations for use:**

- For fast, easy cutting with minimized burr formation
- For use on angle grinders of all output categories
- The use of large clamping flanges (SFS 76, page 48) increases lateral stability and ensures accurate wheel guidance, in particular for thin cut-off wheels of the flat type with dia. 178 and 230 mm

**PFERDERGONOMICS®:**

Thin cut-off wheels < 2.0 mm:

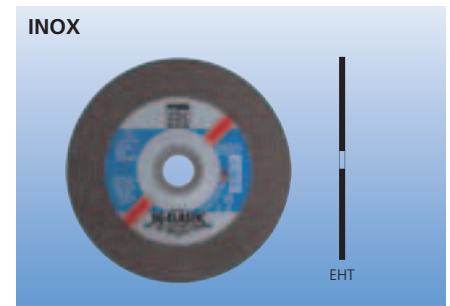
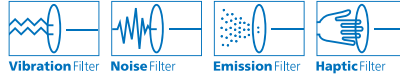

Description	EAN 4007220	EN designation	D x T/U x H [mm (inch)]	Max. perm. speed [RPM]	
<b>Flat type EHT (shape 41)</b>					
EHT 115-1,0 A 60 Q SG-INOX/22,23	957547	41 A 60 Q BF 80	115 x 1.0 x 22.23 (7/8)	13,300	25
EHT 115-1,6 A 46 Q SG-INOX/22,23	957554	41 A 46 Q BF 80	115 x 1.6 x 22.23 (7/8)	13,300	25
EHT 125-1,0 A 60 Q SG-INOX/22,23	957561	41 A 60 Q BF 80	125 x 1.0 x 22.23 (7/8)	12,200	25
EHT 125-1,6 A 46 Q SG-INOX/22,23	957578	41 A 46 Q BF 80	125 x 1.6 x 22.23 (7/8)	12,200	25
EHT 178-1,6 A 46 Q SG-INOX/22,23	957585	41 A 46 Q BF 80	178 x 1.6 x 22.23 (7/8)	8,600	25
EHT 230-2,0 A 46 Q SG-INOX/22,23	957592	41 A 46 Q BF 80	230 x 2.0 x 22.23 (7/8)	6,600	25



# Cut-off wheels

## Performance Line SG-ELASTIC



### Aluminium/non-ferrous metals

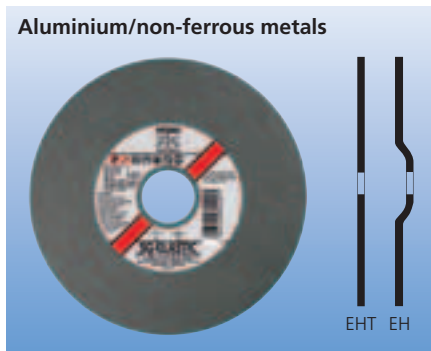

Soft, high-performance tool of hardness N with high cutting performance and very long tool life.

Contains no fillers that could leave undesirable residues on the workpiece. The surface can therefore be welded immediately.

#### Abrasive: Aluminium oxide A

#### Materials to be worked:

Tough and hard aluminium, non-ferrous metals

#### Applications:

Cutting of sheet metal, profiles and solid material

#### Recommendations for use:

- Wheel thicknesses 1.6/1.0 mm for fast, easy cutting with minimized burr formation

- Wheel thickness 2.4 mm for multipurpose cutting work
- Wheel thickness 2.9 mm for maximum tool life with high lateral stability
- Suitable for use on angle grinders of all output categories
- The use of large clamping flanges (SFS 76, page 48) increases the lateral stability and ensures accurate wheel guidance, in particular for thin cut-off wheels of the flat type with dia. 178 and 230 mm

#### PFERDERGONOMICS®:

Thin cut-off wheels < 2.0 mm:



Description	EAN 4007220	EN designation	D x T/U x H [mm (inch)]	Max. perm. speed [RPM]	
<b>Flat type EHT (shape 41)</b>					
EHT 100-1,0 A 60 N SG-ALU/16,0	885222	41 A 60 N BF 80	100 x 1.0 x 16.0 (5/8)	15,300	25
EHT 115-1,0 A 60 N SG-ALU/22,23	804964	41 A 60 N BF 80	115 x 1.0 x 22.23 (7/8)	13,300	25
EHT 115-1,6 A 46 N SG-ALU/22,23	804988	41 A 46 N BF 80	115 x 1.6 x 22.23 (7/8)	13,300	25
EHT 115-2,4 A 30 N SG-ALU/22,23	617892	41 A 30 N BF 80	115 x 2.4 x 22.23 (7/8)	13,300	25
EHT 125-1,0 A 60 N SG-ALU/22,23	804995	41 A 60 N BF 80	125 x 1.0 x 22.23 (7/8)	12,200	25
EHT 125-1,6 A 46 N SG-ALU/22,23	805008	41 A 46 N BF 80	125 x 1.6 x 22.23 (7/8)	12,200	25
EHT 125-2,4 A 30 N SG-ALU/22,23	617786	41 A 30 N BF 80	125 x 2.4 x 22.23 (7/8)	12,200	25
EHT 150-1,6 A 46 N SG-ALU/22,23	953426	41 A 46 N BF 80	150 x 1.6 x 22.23 (7/8)	10,200	25
EHT 178-1,6 A 46 N SG-ALU/22,23	805015	41 A 46 N BF 80	178 x 1.6 x 22.23 (7/8)	8,600	25
EHT 178-2,9 A 24 N SG-ALU/22,23	538487	41 A 24 N BF 80	178 x 2.9 x 22.23 (7/8)	8,600	25
EHT 230-2,9 A 24 N SG-ALU/22,23	538524	41 A 24 N BF 80	230 x 2.9 x 22.23 (7/8)	6,600	25
<b>Depressed-centre type EH (shape 42)</b>					
EH 115-2,4 A 30 N SG-ALU/22,23	522936	42 A 30 N BF 80	115 x 2.4 x 22.23 (7/8)	13,300	25
EH 125-2,4 A 30 N SG-ALU/22,23	389027	42 A 30 N BF 80	125 x 2.4 x 22.23 (7/8)	12,200	25
EH 178-2,9 A 24 N SG-ALU/22,23	538517	42 A 24 N BF 80	178 x 2.9 x 22.23 (7/8)	8,600	25
EH 230-2,9 A 24 N SG-ALU/22,23	538548	42 A 24 N BF 80	230 x 2.9 x 22.23 (7/8)	6,600	25



Hard, high-performance tool of hardness R (C) with high cutting performance, high lateral stability and very long tool life.

**Abrasive: Silicon carbide C**

**Materials to be worked:**

Natural stone, synthetic stone, fire-resistant stone, cast iron, non-ferrous metals

**Applications:**

Cutting of solid material and profiles

**Recommendations for use:**

- Wheel thickness 2.4 mm for multipurpose cutting work
- Wheel thicknesses 3.2/3.0 mm for maximum tool life with high lateral stability
- Suitable for use on angle grinders of all output categories

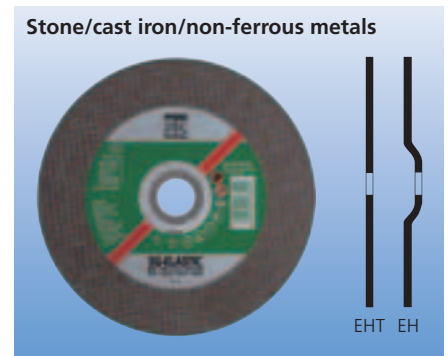

Description	EAN 4007220	EN designation	D x T/U x H [mm (inch)]	Max. perm. speed [RPM]	
<b>Flat type EHT (shape 41)</b>					
EHT 100-2,4 C 46 R SG/16,0	163016	41 C 46 R BF 80	100 x 2.4 x 16.0 (5/8)	15,300	25
EHT 150-3,0 C 24 R SG/22,23	163047	41 C 24 R BF 80	150 x 3.0 x 22.23 (7/8)	10,200	25
EHT 178-3,2 C 24 R SG/22,23	163092	41 C 24 R BF 80	178 x 3.2 x 22.23 (7/8)	8,600	25
EHT 230-3,2 C 24 R SG/22,23	163146	41 C 24 R BF 80	230 x 3.2 x 22.23 (7/8)	6,600	25
<b>Depressed-centre type EH (shape 42)</b>					
EH 115-2,4 C 30 R SG/22,23	163252	42 C 30 R BF 80	115 x 2.4 x 22.23 (7/8)	13,300	25
EH 125-2,4 C 30 R SG/22,23	162996	42 C 30 R BF 80	125 x 2.4 x 22.23 (7/8)	12,200	25
EH 230-3,2 C 24 R SG/22,23	163078	42 C 24 R BF 80	230 x 3.2 x 22.23 (7/8)	6,600	25



# Cut-off wheels

## Performance Line SG-ELASTIC



Medium-hard, multipurpose tool of hardness P with high cutting performance and long tool life for reduced heat build-up during cutting.

**Abrasive: Aluminium oxide A**

Manufactured without addition of ferrous, chlorinated or sulphurous fillers.

**Materials to be worked:**

Steel, stainless steel (INOX), heat-resistant steels, cast iron, non-ferrous metals, nickel-based alloys

**Applications:**

Cutting of sheet metal, profiles and solid material

**Recommendations for use:**

- For multipurpose cutting work

- Specially designed for hard-to-reach places
- For use on electric and air-powered straight grinders of all output categories
- Can be used with mounted arbor on straight grinders up to the maximum rotational speed of the arbor
- Cut-off wheels up to dia. 76 mm can be used without a guard

**Ordering note:**

Please order arbor separately.

**PFERDERGONOMICS®:**

Thin cut-off wheels < 2.0 mm:



Description	EAN 4007220	EN designation	D x T x H [mm (inch)]	Max. perm. speed [RPM] of the cut-off wheel without arbor	Max. perm. speed [RPM] of the cut-off wheel with PFERD arbor	
<b>Flat type EHT (shape 41)</b>						
EHT 30-1,1 A 60 P SG/6,0	165621	41 A 60 P BF 80	30 x 1.1 x 6.0 (1/4)	51,000	31,800	50
EHT 30-1,4 A 60 P SG/6,0	165638	41 A 60 P BF 80	30 x 1.4 x 6.0 (1/4)	51,000	31,800	50
EHT 40-1,1 A 60 P SG/6,0	165645	41 A 60 P BF 80	40 x 1.1 x 6.0 (1/4)	38,200	23,900	50
EHT 40-2,1 A 46 P SG/6,0	165652	41 A 46 P BF 80	40 x 2.1 x 6.0 (1/4)	38,200	23,900	50
EHT 50-0,8 A 60 P SG/6,0	849156	41 A 60 P BF 80	50 x 0.8 x 6.0 (1/4)	30,600	19,100	50
EHT 50-1,1 A 60 P SG/6,0	165669	41 A 60 P BF 80	50 x 1.1 x 6.0 (1/4)	30,600	19,100	50
EHT 50-1,4 A 60 P SG/6,0	165676	41 A 60 P BF 80	50 x 1.4 x 6.0 (1/4)	30,600	19,100	50
EHT 50-2,1 A 46 P SG/6,0	165683	41 A 46 P BF 80	50 x 2.1 x 6.0 (1/4)	30,600	19,100	50
EHT 50-3,0 A 46 P SG/6,0	165690	41 A 46 P BF 80	50 x 3.0 x 6.0 (1/4)	30,600	19,100	50
EHT 65-0,8 A 60 P SG/6,0	849187	41 A 60 P BF 80	65 x 0.8 x 6.0 (1/4)	23,500	14,700	50
EHT 65-0,8 A 60 P SG/10,0	849194	41 A 60 P BF 80	65 x 0.8 x 10.0 (25/64)	23,500	14,700	50
EHT 65-1,1 A 60 P SG/6,0	165706	41 A 60 P BF 80	65 x 1.1 x 6.0 (1/4)	23,500	14,700	50
EHT 65-1,1 A 60 P SG/10,0	165713	41 A 60 P BF 80	65 x 1.1 x 10.0 (25/64)	23,500	14,700	50
EHT 65-1,4 A 60 P SG/10,0	165720	41 A 60 P BF 80	65 x 1.4 x 10.0 (25/64)	23,500	14,700	50
EHT 65-2,1 A 46 P SG/10,0	165737	41 A 46 P BF 80	65 x 2.1 x 10.0 (25/64)	23,500	14,700	50
EHT 65-3,0 A 46 P SG/10,0	165744	41 A 46 P BF 80	65 x 3.0 x 10.0 (25/64)	23,500	14,700	50
EHT 70-1,1 A 60 P SG/10,0	165751	41 A 60 P BF 80	70 x 1.1 x 10.0 (25/64)	21,800	13,600	50
EHT 70-1,4 A 60 P SG/10,0	165768	41 A 60 P BF 80	70 x 1.4 x 10.0 (25/64)	21,800	13,600	50
EHT 70-2,1 A 46 P SG/10,0	165775	41 A 46 P BF 80	70 x 2.1 x 10.0 (25/64)	21,800	13,600	50
EHT 70-3,0 A 46 P SG/10,0	165782	41 A 46 P BF 80	70 x 3.0 x 10.0 (25/64)	21,800	13,600	50
EHT 76-0,8 A 60 P SG/6,0	849217	41 A 60 P BF 80	76 x 0.8 x 6.0 (1/4)	20,100	12,500	50
EHT 76-0,8 A 60 P SG/10,0	849200	41 A 60 P BF 80	76 x 0.8 x 10.0 (25/64)	20,100	12,500	50
EHT 76-1,1 A 60 P SG/6,0	165812	41 A 60 P BF 80	76 x 1.1 x 6.0 (1/4)	20,100	12,500	50
EHT 76-1,1 A 60 P SG/10,0	165829	41 A 60 P BF 80	76 x 1.1 x 10.0 (25/64)	20,100	12,500	50
EHT 76-1,4 A 60 P SG/10,0	165836	41 A 60 P BF 80	76 x 1.4 x 10.0 (25/64)	20,100	12,500	50
EHT 76-2,1 A 46 P SG/10,0	165843	41 A 46 P BF 80	76 x 2.1 x 10.0 (25/64)	20,100	12,500	50
EHT 76-3,0 A 46 P SG/10,0	165850	41 A 46 P BF 80	76 x 3.0 x 10.0 (25/64)	20,100	12,500	50





Tool dia. [mm]	Max. perm. speed [RPM]
30	31,800
40	23,900
50	19,100
65	14,700
70	13,600
76	12,500

Accessory for mounting small cut-off wheels on straight grinders. Stable arrangement with high shank breakage resistance.

**Safety notes:**

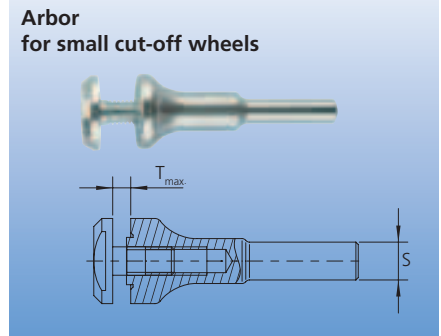
- When using this arbor, please observe the maximum permissible rotational speed indicated on the instruction sheet. Arbors with mounted cut-off wheels can be used up to the maximum speed permitted for the arbor (see table).



Description	EAN 4007220	Shank dia. S [mm]	Tool centre hole dia. [mm]	Max. tool width T <sub>max</sub> [mm]	
BO 6/6 0-4	219119	6	6	0-4	1
BO 6,35/6 0-4 (1/4)	219126	6.35	6	0-4	1
BO 6/10 0-4	219140	6	10	0-4	1
BO 6,35/10 0-4 (1/4)	219133	6.35	10	0-4	1
BO 8/10 0-4	219157	8	10	0-4	1



# Cut-off wheels

## Performance Line SG-ELASTIC (dia. 300–400 mm)

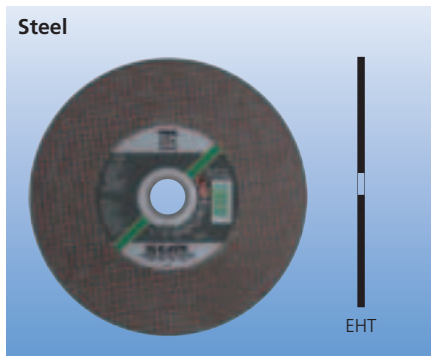

Hard, special tool of hardness S with high cutting performance and long tool life for use on hand-held cut-off machines (wheel dia. 300–400 mm).

**Abrasive: Aluminium oxide A**

**Materials to be worked:**  
Steel, cast iron

**Applications:**  
Cutting of solid material and profiles

- Recommendations for use:**
- Can be used on hand-held cut-off machines with electric, high-frequency or petrol motors
  - Alternative wheels with dia. 300 mm for 80 m/s and 100 m/s are available to match existing machines

**Ordering note:**  
When ordering, please specify centre hole dia. and desired maximum operating speed (80 or 100 m/s).

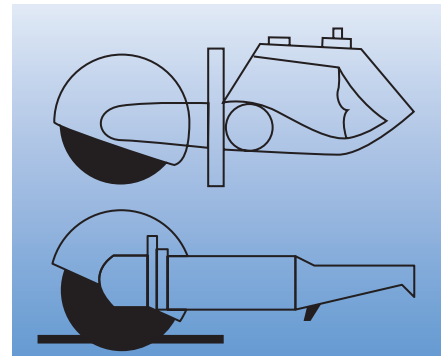

Description	EAN 4007220	EN designation	D x T x H [mm (inch)]	Max. perm. speed [RPM]	
<b>Maximum operating speed 80 m/s, flat type EHT (shape 41)</b>					
80 EHT 300-4,0 A 24 S SG/20,0	162460	41 A 24 S BF 80	300 x 4.0 x 20.0	5,100	20
80 EHT 300-4,0 A 24 S SG/22,23	162477	41 A 24 S BF 80	300 x 4.0 x 22.23 (7/8)	5,100	20
80 EHT 300-4,0 A 24 S SG/25,4	162484	41 A 24 S BF 80	300 x 4.0 x 25.4 (1)	5,100	20
<b>Maximum operating speed 100 m/s, flat type EHT (shape 41)</b>					
100 EHT 300-4,0 A 24 S SG/20,0	540008	41 A 24 S BF 100	300 x 4.0 x 20.0	6,400	20
100 EHT 300-4,0 A 24 S SG/22,23	540015	41 A 24 S BF 100	300 x 4.0 x 22.23 (7/8)	6,400	20
100 EHT 300-4,0 A 24 S SG/25,4	540022	41 A 24 S BF 100	300 x 4.0 x 25.4 (1)	6,400	20
100 EHT 350-4,5 A 24 S SG/20,0	540039	41 A 24 S BF 100	350 x 4.5 x 20.0	5,500	10
100 EHT 350-4,5 A 24 S SG/22,23	540046	41 A 24 S BF 100	350 x 4.5 x 22.23 (7/8)	5,500	10
100 EHT 350-4,5 A 24 S SG/25,4	540053	41 A 24 S BF 100	350 x 4.5 x 25.4 (1)	5,500	10
100 EHT 400-4,8 A 24 S SG/20,0	953433	41 A 24 S BF 100	400 x 4.8 x 20.0	4,800	10
100 EHT 400-4,8 A 24 S SG/22,23	540060	41 A 24 S BF 100	400 x 4.8 x 22.23 (7/8)	4,800	10
100 EHT 400-4,8 A 24 S SG/25,4	540077	41 A 24 S BF 100	400 x 4.8 x 25.4 (1)	4,800	10



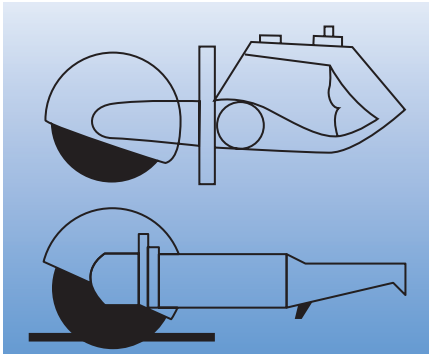

Hard, special tool of hardness R (C) with high cutting performance and long tool life for use on hand-held cut-off machines (wheel dia. 300–350 mm).

**Abrasive: Silicon carbide C**

**Materials to be worked:**

Natural stone, fire-resistant stone, cast iron, non-ferrous metals

**Applications:**

Cutting of solid material and profiles

**Recommendations for use:**

- Can be used on hand-held cut-off machines with electric, high-frequency or petrol motors
- Alternative wheels with dia. 300 mm for 80 m/s and 100 m/s are available to match existing machines

**Ordering note:**

When ordering, please specify centre hole dia. and desired maximum operating speed (80 or 100 m/s).

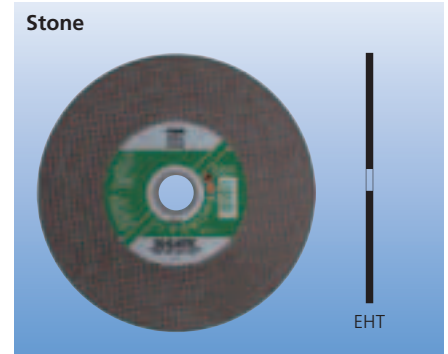

Description	EAN 4007220	EN designation	D x T x H [mm (inch)]	Max. perm. speed [RPM]	
<b>Maximum operating speed 80 m/s, flat type EHT (shape 41)</b>					
80 EHT 300-4,0 C 24 R SG/20,0	163177	41 C 24 R BF 80	300 x 4.0 x 20.0	5,100	20
80 EHT 300-4,0 C 24 R SG/22,23	163184	41 C 24 R BF 80	300 x 4.0 x 22.23 (7/8)	5,100	20
80 EHT 300-4,0 C 24 R SG/25,4	163191	41 C 24 R BF 80	300 x 4.0 x 25.4 (1)	5,100	20
<b>Maximum operating speed 100 m/s, flat type EHT (shape 41)</b>					
100 EHT 350-4,5 C 24 R SG/20,0	540145	41 C 24 R BF 100	350 x 4.5 x 20.0	5,500	10
100 EHT 350-4,5 C 24 R SG/22,23	540152	41 C 24 R BF 100	350 x 4.5 x 22.23 (7/8)	5,500	10
100 EHT 350-4,5 C 24 R SG/25,4	540169	41 C 24 R BF 100	350 x 4.5 x 25.4 (1)	5,500	10

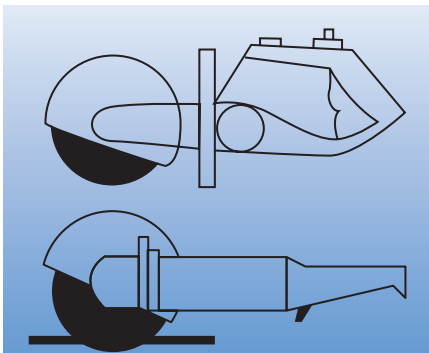

Medium-hard, special tool of hardness Q with high cutting performance and long tool life, for use on hand-held cut-off machines (wheel dia. 300–350 mm).

**Abrasive: Aluminium oxide/ silicon carbide AC**

**Materials to be worked:**

Cast iron, reinforced concrete, ductile materials

**Applications:**

Cutting of composite materials

**Recommendations for use:**

- Can be used on hand-held cut-off machines with electric, high-frequency or petrol motors

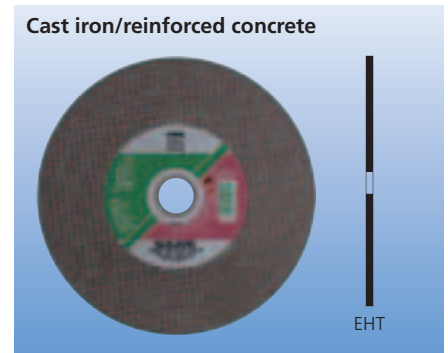

Description	EAN 4007220	EN designation	D x T x H [mm (inch)]	Max. perm. speed [RPM]	
<b>Maximum operating speed 100 m/s, flat type EHT (shape 41)</b>					
100 EHT 300-4,0 AC 24 Q SG/20,0	540084	41 AC 24 Q BF 100	300 x 4.0 x 20.0	6,400	20
100 EHT 300-4,0 AC 24 Q SG/22,23	540091	41 AC 24 Q BF 100	300 x 4.0 x 22.23 (7/8)	6,400	20
100 EHT 300-4,0 AC 24 Q SG/25,4	540107	41 AC 24 Q BF 100	300 x 4.0 x 25.4 (1)	6,400	20
100 EHT 350-4,5 AC 24 Q SG/20,0	540114	41 AC 24 Q BF 100	350 x 4.5 x 20.0	5,500	10
100 EHT 350-4,5 AC 24 Q SG/22,23	540121	41 AC 24 Q BF 100	350 x 4.5 x 22.23 (7/8)	5,500	10
100 EHT 350-4,5 AC 24 Q SG/25,4	540138	41 AC 24 Q BF 100	350 x 4.5 x 25.4 (1)	5,500	10

# Cut-off wheels

## Special Line SG-PLUS



Very hard, extremely resistant high-performance tool of hardness T with very high cutting performance and outstanding tool life.

**Abrasive: Aluminium oxide A**

**Materials to be worked:**

Steel

**Applications:**

Cutting of sheet metal, profiles and solid material

**Recommendations for use:**

■ Wheel thicknesses 1.6/1.0 mm for fast, easy cutting with minimized burr formation

- Wheel thicknesses 2.5/2.4 mm for multipurpose cutting work with maximum tool life
- Wheel thickness 2.8 mm for maximum tool life with high lateral stability
- Achieves best cutting results on high-performance angle grinders

**PFERDERGONOMICS®:**

Thin cut-off wheels < 2.0 mm:



Description	EAN 4007220	EN designation	D x T/U x H [mm (inch)]	Max. perm. speed [RPM]	
<b>Flat type EHT (shape 41)</b>					
EHT 105-1,0 A 60 T SGP/16,0	953440	41 A 60 T BF 80	105 x 1.0 x 16.0 (5/8)	14,500	25
EHT 115-1,0 A 60 T SGP/22,23	538043	41 A 60 T BF 80	115 x 1.0 x 22.23 (7/8)	13,300	25
EHT 115-2,4 A 30 T SGP/22,23	248133	41 A 30 T BF 80	115 x 2.4 x 22.23 (7/8)	13,300	25
EHT 125-1,0 A 60 T SGP/22,23	538050	41 A 60 T BF 80	125 x 1.0 x 22.23 (7/8)	12,200	25
EHT 125-2,4 A 30 T SGP/22,23	248140	41 A 30 T BF 80	125 x 2.4 x 22.23 (7/8)	12,200	25
EHT 150-1,6 4 46 T SGP/22,23	953457	41 A 46 T BF 80	150 x 1.6 x 22.23 (7/8)	10,200	25
EHT 178-2,5 A 24 T SGP/22,23	522707	41 A 24 T BF 80	178 x 2.5 x 22.23 (7/8)	8,600	25
EHT 178-2,8 A 24 T SGP/22,23	162392	41 A 24 T BF 80	178 x 2.8 x 22.23 (7/8)	8,600	25
EHT 230-2,5 A 24 T SGP/22,23	522721	41 A 24 T BF 80	230 x 2.5 x 22.23 (7/8)	6,600	25
EHT 230-2,8 A 24 T SGP/22,23	162453	41 A 24 T BF 80	230 x 2.8 x 22.23 (7/8)	6,600	25
<b>Depressed-centre type EH (shape 42)</b>					
EH 115-2,4 A 30 T SGP/22,23	248126	42 A 30 T BF 80	115 x 2.4 x 22.23 (7/8)	13,300	25
EH 125-2,4 A 30 T SGP/22,23	248157	42 A 30 T BF 80	125 x 2.4 x 22.23 (7/8)	12,200	25
EH 178-2,5 A 24 T SGP/22,23	522714	42 A 24 T BF 80	178 x 2.5 x 22.23 (7/8)	8,600	25
EH 178-2,8 A 24 T SGP/22,23	162293	42 A 24 T BF 80	178 x 2.8 x 22.23 (7/8)	8,600	25
EH 230-2,8 A 24 T SGP/22,23	162330	42 A 24 T BF 80	230 x 2.8 x 22.23 (7/8)	6,600	25





Hard, extremely resistant high-performance tool of hardness S (INOX) with very high cutting performance and outstanding tool life.

**Abrasive: Aluminium oxide A**

Manufactured without addition of ferrous, chlorinated or sulphurous fillers.

**Materials to be worked:**

Stainless steel (INOX)

**Applications:**

Cutting of sheet metal, profiles and solid material

**Recommendations for use:**

- X-SLIM® type (0.8 mm) for very fast, cool and particularly thin cuts with minimized burr formation. Ergonomic and convenient with a high degree of safety.
- Wheel thicknesses 1.9/1.6/1.0 mm for cool, fast, convenient cutting with minimized burr formation and maximum tool life

- Wheel thicknesses 2.3/2.2 mm for multipurpose cutting work with maximum tool life
- Wheel thicknesses 2.8/2.5 for maximum tool life with high lateral stability
- Achieves best cutting results on high-performance angle grinders
- Disc thicknesses 1.0/0.8 mm, ideal for use on battery-powered angle grinders
- The use of large clamping flanges (SFS 76, page 48) increases the lateral stability and ensures accurate wheel guidance, in particular for thin cut-off wheels of the flat type with dia. 178 and 230 mm



**PFERDERGONOMICS®:**

Thin cut-off wheels < 2.0 mm:



Description	EAN 4007220	EN designation	D x T/U x H [mm (inch)]	Max. perm. speed [RPM]	
<b>Flat type EHT (shape 41)</b>					
EHT 100-0,8 A 60 S SGP-INOX X-SLIM/16,0	845103	41 A 60 S BF 80	100 x 0.8 x 16.0 (5/8)	15,300	25
EHT 100-1,0 A 60 S SGP-INOX/16,0	538067	41 A 60 S BF 80	100 x 1.0 x 16.0 (5/8)	15,300	25
EHT 105-0,8 A 60 S SGP-INOX X-SLIM/16,0	953464	41 A 60 S BF 80	105 x 0.8 x 16.0 (5/8)	14,500	25
EHT 105-1,0 A 60 S SGP-INOX/16,0	953471	41 A 60 S BF 80	105 x 1.0 x 16.0 (5/8)	14,500	25
EHT 115-0,8 A 60 S SGP-INOX X-SLIM/22,23	835357	41 A 60 S BF 80	115 x 0.8 x 22.23 (7/8)	13,300	25
EHT 115-1,0 A 60 S SGP-INOX/22,23	538074	41 A 60 S BF 80	115 x 1.0 x 22.23 (7/8)	13,300	25
EHT 115-1,6 A 46 S SGP-INOX/22,23	538081	41 A 46 S BF 80	115 x 1.6 x 22.23 (7/8)	13,300	25
EHT 115-2,2 A 46 S SGP-INOX/22,23	281956	41 A 46 S BF 80	115 x 2.2 x 22.23 (7/8)	13,300	25
EHT 125-0,8 A 60 S SGP-INOX X-SLIM/22,23	835364	41 A 60 S BF 80	125 x 0.8 x 22.23 (7/8)	12,200	25
EHT 125-1,0 A 60 S SGP-INOX/22,23	538098	41 A 60 S BF 80	125 x 1.0 x 22.23 (7/8)	12,200	25
EHT 125-1,6 A 46 S SGP-INOX/22,23	538104	41 A 46 S BF 80	125 x 1.6 x 22.23 (7/8)	12,200	25
EHT 125-2,2 A 46 S SGP-INOX/22,23	281970	41 A 46 S BF 80	125 x 2.2 x 22.23 (7/8)	12,200	25
EHT 150-1,6 A 46 S SGP-INOX/22,23	953488	41 A 46 S BF 80	150 x 1.6 x 22.23 (7/8)	10,200	25
EHT 150-2,5 A 46 S SGP-INOX/22,23	953495	41 A 46 S BF 80	150 x 2.5 x 22.23 (7/8)	10,200	25
EHT 178-1,6 A 46 S SGP-INOX/22,23	357873	41 A 46 S BF 80	178 x 1.6 x 22.23 (7/8)	8,600	25
EHT 178-2,3 A 24 S SGP-INOX/22,23	522752	41 A 24 S BF 80	178 x 2.3 x 22.23 (7/8)	8,600	25
EHT 178-2,8 A 24 S SGP-INOX/22,23	281994	41 A 24 S BF 80	178 x 2.8 x 22.23 (7/8)	8,600	25
EHT 230-1,9 A 46 S SGP-INOX/22,23	522776	41 A 46 S BF 80	230 x 1.9 x 22.23 (7/8)	6,600	25
EHT 230-2,3 A 24 S SGP-INOX/22,23	522783	41 A 24 S BF 80	230 x 2.3 x 22.23 (7/8)	6,600	25
EHT 230-2,8 A 24 S SGP-INOX/22,23	282014	41 A 24 S BF 80	230 x 2.8 x 22.23 (7/8)	6,600	25
<b>Depressed-centre type EH (shape 42)</b>					
EH 115-2,2 A 46 S SGP-INOX/22,23	281963	42 A 46 S BF 80	115 x 2.2 x 22.23 (7/8)	13,300	25
EH 125-2,2 A 46 S SGP-INOX/22,23	281987	42 A 46 S BF 80	125 x 2.2 x 22.23 (7/8)	12,200	25
EH 178-2,8 A 24 S SGP-INOX/22,23	282007	42 A 24 S BF 80	178 x 2.8 x 22.23 (7/8)	8,600	25
EH 230-2,3 A 24 S SGP-INOX/22,23	522790	42 A 24 S BF 80	230 x 2.3 x 22.23 (7/8)	6,600	25
EH 230-2,8 A 24 S SGP-INOX/22,23	282021	42 A 24 S BF 80	230 x 2.8 x 22.23 (7/8)	6,600	25



**PFERDVIDEO**  
You will receive more information here or at [www.pferd.com](http://www.pferd.com)

# Cut-off wheels

## Performance Line SG-ELASTIC

### Foundry cut-off wheels

To match the hard conditions encountered on air turbine grinders and powerful high-frequency or electric angle grinders in foundries, PFERD has developed cut-off wheels which meet particularly high quality and safety standards.

PFERD cut-off wheels for foundries perform very well on casting scale with sand contamination, cast iron, cast iron with flake graphite, cast iron with nodular graphite/nodular cast iron, as well as on steel.

Cutting off risers and cutting of all kinds are the most common applications in tough foundry use.

For all matters relating to work in foundries, PFERD offers you targeted and individual support. Our experienced sales representatives and technical advisors will be pleased to assist you. Please contact us.

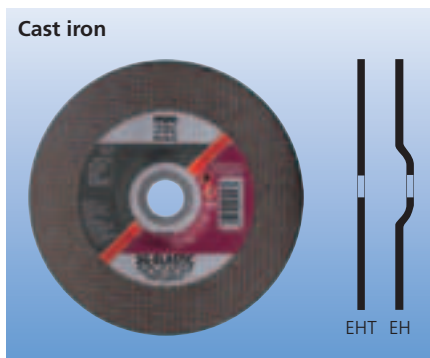

Soft, multipurpose tool of hardness P (CAST) with high cutting performance, high lateral stability and long tool life.

**Abrasive: Aluminium oxide A**

**Materials to be worked:**

Cast iron, steel

**Applications:**

Cutting of solid material and profiles

**Recommendations for use:**

- Provides optimum cutting results on air turbine grinders and powerful high-frequency or electric angle grinders

Description	EAN 4007220	EN designation	D x T/U x H [mm (inch)]	Max. perm. speed [RPM]	
<b>Flat type EHT (shape 41)</b>					
EHT 230-3,2 A 24 P SG/22,23	952542	41 A 24 P BF 80	230 x 3.2 x 22.23 (7/8)	6,600	25
<b>Depressed-centre type EH (shape 42)</b>					
EH 230-3,2 A 24 P SG/22,23	952535	42 A 24 P BF 80	230 x 3.2 x 22.23 (7/8)	6,600	25

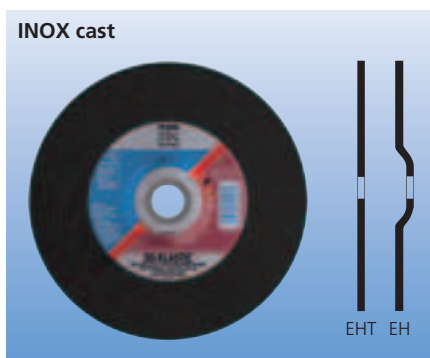

Medium-hard, high-performance tool of hardness Q (INOX-CAST) with high cutting performance, high lateral stability and very long tool life.

**Abrasive: Aluminium oxide A**

Manufactured without addition of ferrous, chlorinated and sulphurous fillers.

**Materials to be worked:**

INOX cast, cast steel

**Applications:**

Cutting of solid material and profiles

**Recommendations for use:**

- Provides optimum cutting results on air turbine grinders and powerful high-frequency or electric angle grinders

Description	EAN 4007220	EN designation	D x T/U x H [mm (inch)]	Max. perm. speed [RPM]	
<b>Flat type EHT (shape 41)</b>					
EHT 230-2,9 A 24 Q SG-INOX-Guss/22,23	522899	41 A 24 Q BF 80	230 x 2.9 x 22.23 (7/8)	6,600	25
<b>Depressed-centre type EH (shape 42)</b>					
EH 230-2,9 A 24 Q SG-INOX-Guss/22,23	522905	42 A 24 Q BF 80	230 x 2.9 x 22.23 (7/8)	6,600	25

Medium-hard, high-performance tool of hardness Q (CAST) with high cutting performance, high lateral stability and very long tool life.

**Abrasive: Aluminium oxide/silicon carbide AC**

**Materials to be worked:**

Cast iron with flake graphite, cast iron with nodular graphite/nodular cast iron

**Applications:**

Cutting of solid material and profiles

**Recommendations for use:**

■ Provides optimum cutting results on air turbine grinders and powerful high-frequency or electric angle grinders

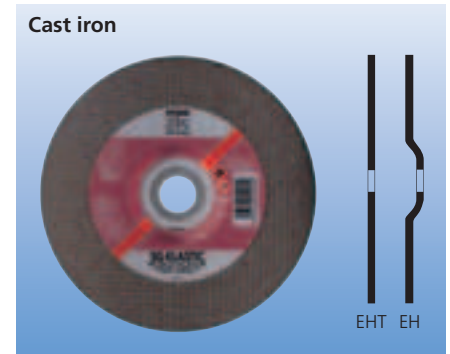

Description	EAN 4007220	EN designation	D x T/U x H [mm (inch)]	Max. perm. speed [RPM]	
<b>Flat type EHT (shape 41)</b>					
EHT 230-3,2 AC 24 Q SG/22,23	522912	41 AC 24 Q BF 80	230 x 3.2 x 22.23 (7/8)	6,600	25
<b>Depressed-centre type EH (shape 42)</b>					
EH 230-3,2 AC 24 Q SG/22,23	522929	42 AC 24 Q BF 80	230 x 3.2 x 22.23 (7/8)	6,600	25

Medium-hard, extremely resilient high-performance tool of hardness Q (CAST) with very high cutting performance, high lateral stability and outstanding tool life.

**Abrasive: Zirconia alumina/aluminium oxide ZA**

**Materials to be worked:**

Cast iron with flake graphite, cast iron with nodular graphite/nodular cast iron

**Applications:**

Cutting of solid material and profiles

**Recommendations for use:**

■ Preferably for use on air turbine grinders and powerful high-frequency or electric angle grinders

**Special Line SG-PLUS**

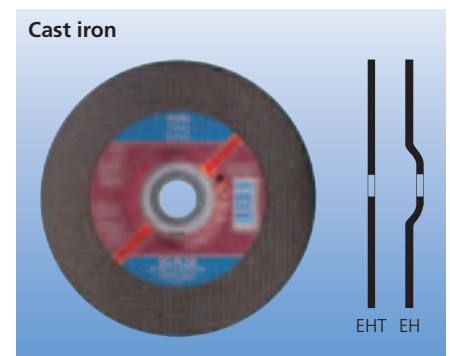

Description	EAN 4007220	EN designation	D x T/U x H [mm (inch)]	Max. perm. speed [RPM]	
<b>Flat type EHT (shape 41)</b>					
EHT 230-3,4 ZA 24 Q SGP/22,23	522837	41 ZA 24 Q BF 80	230 x 3.4 x 22.23 (7/8)	6,600	25
<b>Depressed-centre type EH (shape 42)</b>					
EH 230-3,4 ZA 24 Q SGP/22,23	522844	42 ZA 24 Q BF 80	230 x 3.4 x 22.23 (7/8)	6,600	25

 For detailed information and ordering data on electroplated diamond cut-off wheels, please refer to Catalogue 205.

 **PFERDINFORMATION**  
 You will receive more information here or at [www.pferd.com](http://www.pferd.com)

 Electroplated diamond cut-off wheels can also be used for cutting off risers, feeders, sprues, parting lines or burrs on grey and nodular cast iron (GG/GGG and GJL/GJS) workpieces. They are characterized by an exceptionally long tool life and an ideal cutting performance when working in deep-laying areas (due to constant tool diameter). In addition, they allow quick and comfortable elimination of burning-in.



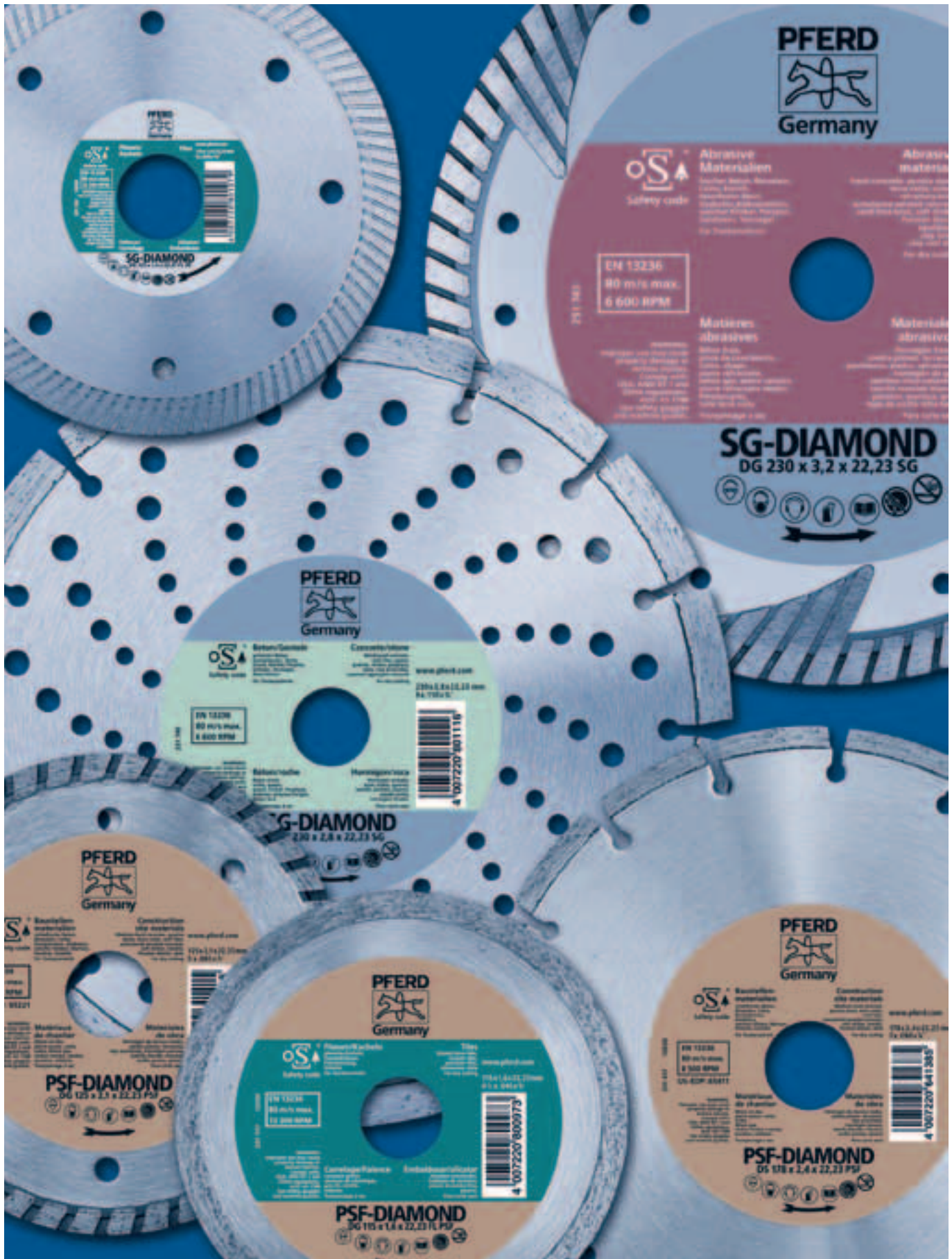



PFERD diamond cut-off wheels are manufactured in compliance with the highest quality and safety standards. They guarantee the best cutting results and allow economic work on diverse materials, such as concrete, exposed aggregate concrete, clinker, hard stone, granite or other abrasive construction materials. The wide product range offers the best tool for every application.

PFERD diamond cut-off wheels are characterized by:

- First-rate diamond qualities
- Excellent cutting characteristics and short cutting times
- Long tool life
- Excellent cutting ease
- High economic value

PFERD quality is certified according to ISO 9001.

### PFERD description

DG 230 x 2.8 x 22.23 SG

① ② ③ ④ ⑤

#### ① Description and shape of the tool

- DS = Diamond, segmented type
- DG = Diamond, continuous rim type for flags and tiles

#### ② Outer diameter

Outer dia. D in [mm]

#### ③ Wheel thickness

Wheel thickness T in [mm]

#### ④ Centre hole diameter

Centre hole dia. H in [mm]

#### ⑤ PFERD product line

- Universal Line PSF
- Performance Line SG

The PFERD description corresponds to the designation conforming to EN 13236.

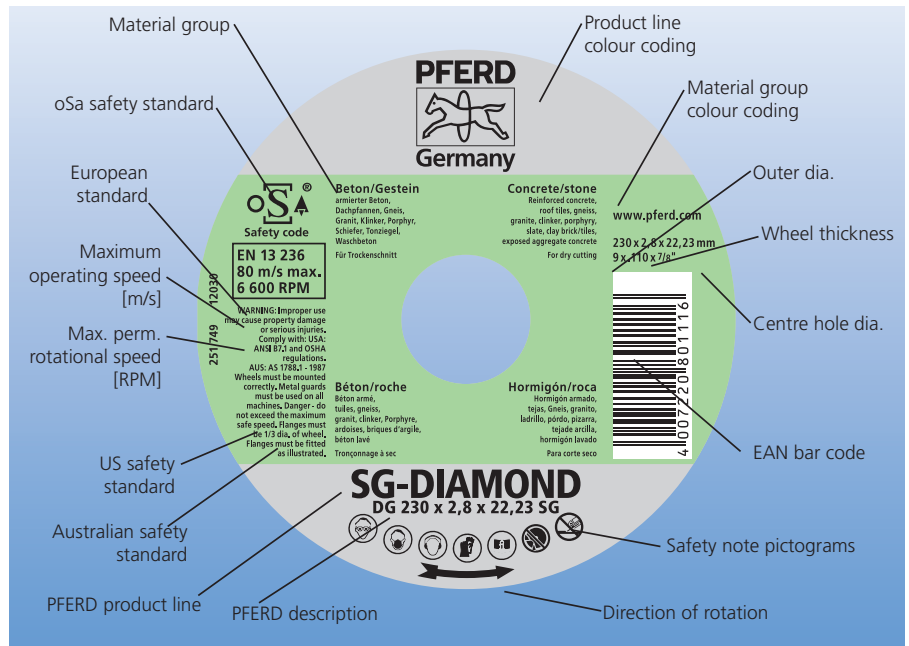

### Colour coding of the two product lines and materials to be worked

PFERD diamond cut-off wheels for diverse cutting applications in construction work, crafts and industry are available in two product lines with diverse special features:

Universal Line PSF		
General use in construction, crafts and industry		
Material = Colour		Page
	Construction site materials = orange	66
	Flags/tiles = dark green	66

Performance Line SG		
Widest range of tools for professional use in construction, crafts and industry		
Material = Colour		Page
	Abrasive materials = signal red	68
	Concrete/stone = light green	67
	Flags/tiles = dark green	68

### The fast way to the best tool

Starting with the application ① and material ②, the overview shows the various types of tools in the PFERD range and helps you to find the best tool. For information on tool drives, please refer to the respective catalogue page.

① Application	② Material		③ Material		④ Material		⑤ Material	
	Type	Page	Type	Page	Type	Page	Type	Page
Aggressive, fast cutting	DS PSF	66	–	–	DS SG	67	–	–
Easy cutting with high-quality cut	DG PSF	66	DG SG	68	–	–	DG FL PSF	68
							DG FL SG	68

# Diamond cut-off wheels

## Universal Line PSF

### Construction site materials Type DS



Multipurpose segmented-edge tool for aggressive, fast cutting with high cutting performance and long tool life.

**Abrasive: Diamond D**

**Materials to be worked:**  
Construction site materials

**Applications:**  
Aggressive, fast cutting of solid material

**Recommendations for use:**

- Suitable for use on angle grinders of all output categories

Description	EAN 4007220	D [mm]	H [mm]	H [inch]	Width T [mm]	Segment height X [mm]	Max. perm. speed [RPM]	
DS 115 x 2,2 x 22,23 PSF	641361	115	22.23	7/8	2.2	7	13,300	1
DS 125 x 2,2 x 22,23 PSF	641378	125	22.23	7/8	2.2	7	12,200	1
DS 178 x 2,4 x 22,23 PSF	641385	178	22.23	7/8	2.4	7	8,500	1
DS 230 x 2,4 x 22,23 PSF	641392	230	22.23	7/8	2.4	7	6,600	1

### Construction site materials Type DG



Multipurpose continuous-edge tool for easy cutting with high cutting performance and long tool life.

**Abrasive: Diamond D**

**Materials to be worked:**  
Construction site materials

**Applications:**  
Easy cutting of solid material with high cutting quality

**Recommendations for use:**

- Suitable for use on angle grinders of all output categories

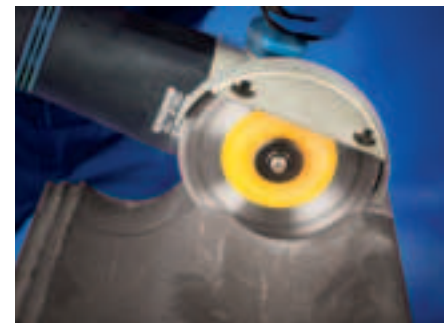

Description	EAN 4007220	D [mm]	H [mm]	H [inch]	Width T [mm]	Segment height X [mm]	Max. perm. speed [RPM]	
DG 115 x 2,1 x 22,23 PSF	641408	115	22.23	7/8	2.1	7	13,300	1
DG 125 x 2,1 x 22,23 PSF	641415	125	22.23	7/8	2.1	7	12,200	1
DG 178 x 2,4 x 22,23 PSF	641422	178	22.23	7/8	2.4	7	8,500	1
DG 230 x 2,6 x 22,23 PSF	641439	230	22.23	7/8	2.6	7	6,600	1

### Flags/tiles Type DG FL



Multipurpose continuous-edge tool for cutting without edge breakages on workpieces with high-quality surfaces. High cutting performance and long tool life.

**Abrasive: Diamond D**

**Materials to be worked:**  
Flags, tiles

**Applications:**  
Easy cutting of flags and tiles with high cutting quality

**Recommendations for use:**

- Suitable for use on angle grinders of all output categories

Description	EAN 4007220	D [mm]	H [mm]	H [inch]	Width T [mm]	Segment height X [mm]	Max. perm. speed [RPM]	
DG 115 x 1,6 x 22,23 FL PSF	800973	115	22.23	7/8	1.6	7	13,300	1
DG 125 x 1,6 x 22,23 FL PSF	800980	125	22.23	7/8	1.6	7	12,200	1

High-performance segmented-edge tool for aggressive, fast cutting of hard materials with high cutting performance and very long tool life.

**Abrasive: Diamond D**

**Materials to be worked:**

Reinforced concrete, roofing tiles, gneiss, granite, clinker, porphyry, slate, clay tile, exposed aggregate concrete, hard concrete, concrete blocks, concrete pipes

**Applications:**

Aggressive, fast cutting of solid material

**Recommendations for use:**

- The maximum operating speed for diamond cut-off wheels DS with dia. 300 to 400 mm is 100 m/s
- Suitable for use on angle grinders of all output categories

**Ordering note:**

All diamond cut-off wheels with centre hole dia. 25.4 mm are supplied with reducing ring to 22.23 mm for use on angle grinders.

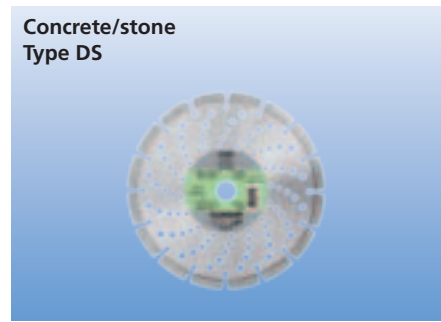

Concrete/stone  
Type DS

Description	EAN 4007220	D [mm]	H [mm]	H [inch]	Width T [mm]	Segment height X [mm]	Max. perm. speed [RPM]	
DS 115 x 2,4 x 22,23 SG	801086	115	22.23	7/8	2.4	10	13,300	1
DS 125 x 2,4 x 22,23 SG	801093	125	22.23	7/8	2.4	10	12,200	1
DS 178 x 2,6 x 22,23 SG	801109	178	22.23	7/8	2.6	10	8,500	1
DS 230 x 2,8 x 22,23 SG	801116	230	22.23	7/8	2.8	10	6,600	1
DS 300 x 2,8 x 20,0 SG	801123	300	20.0	-	2.8	10	6,400	1
DS 300 x 2,8 x 25,4 SG	801147	300	25.4 (22.23)	1 (7/8)	2.8	10	6,400	1
DS 350 x 2,8 x 20,0 SG	801154	350	20.0	-	2.8	10	5,400	1
DS 350 x 2,8 x 25,4 SG	801161	350	25.4 (22.23)	1 (7/8)	2.8	10	5,400	1
DS 400 x 3,2 x 25,4 SG	801178	400	25.4 (22.23)	1 (7/8)	3.2	10	4,800	1

## Sharpening block

Special accessories for reshaping or reconditioning cutting segments. Type with soft polyurethane bond.

**Abrasive: Silicon carbide C**

**Recommendations for use:**

- PFERD diamond cut-off wheels can be reshaped or reconditioned, as required, by cutting off thin slices with the sharpening block



Sharpening block DSB

Description	EAN 4007220	Grit size	Dimensions [mm]	
DSB 2005025	168332	80	200 x 25 x 50.0	1



# Diamond cut-off wheels

## Performance Line SG

### Abrasive materials Type DG



High-performance continuous-edge tool for easy cutting with high cutting performance and very long tool life.

**Abrasive: Diamond D**

**Materials to be worked:**

Fresh concrete, pumice, cotto, screed, fire-resistant stone, aerated concrete, lime malm brick, soft clinker, poroton, sandstone, clay tile

**Applications:**

Easy cutting of solid material with high cutting quality

**Recommendations for use:**

- Suitable for use on angle grinders of all output levels

Description	EAN 4007220	D [mm]	H [mm]	H [inch]	Width T [mm]	Segment height X [mm]	Max. perm. speed [RPM]	
DG 115 x 2,2 x 22,23 SG	801000	115	22.23	7/8	2.2	8	13,300	1
DG 125 x 2,2 x 22,23 SG	801024	125	22.23	7/8	2.2	8	12,200	1
DG 178 x 2,5 x 22,23 SG	801031	178	22.23	7/8	2.5	8	8,500	1
DG 230 x 2,8 x 22,23 SG	801048	230	22.23	7/8	2.8	8	6,600	1

### Flags/tiles Type DG FL

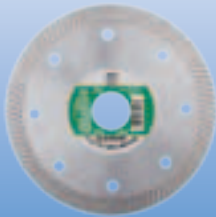

High-performance continuous-edge tool for cutting without edge breakages on workpieces with high-quality surfaces. High cutting performance and very long tool life.

**Abrasive: Diamond D**

**Materials to be worked:**

Glazed tiles, ceramic tiles, stoneware, slate

**Applications:**

Easy cutting of flags and tiles with high cutting quality

**Recommendations for use:**

- Suitable for use on angle grinders of all output levels

Description	EAN 4007220	D [mm]	H [mm]	H [inch]	Width T [mm]	Segment height X [mm]	Max. perm. speed [RPM]	
DG 115 x 1,4 x 22,23 FL SG	801055	115	22.23	7/8	1.4	8	13,300	1
DG 125 x 1,4 x 22,23 FL SG	801079	125	22.23	7/8	1.4	8	12,200	1



Printed in Germany.

Subject to technical modifications.

02/2014

832 106

