



INDUSTRIAL TOOL & MACHINERY SALES

Holemaker
QUALITY EUROPEAN MADE MAGNETIC DRILLING MACHINES

TRADEMASTER
INDUSTRIAL TOOLS

GROZ

m7

Drill Doctor
The Drill Bit Sharpener

Star



WIKUT
CUTTING TOOLS

MACC

EHOMA
Superior Clamping Force

NPK

WORK SHARP
The Tool Sharpener

DAREX
WORLD'S BEST SELLING INDUSTRIAL DRILL SHARPENERS

CATALOGUE
MARCH 2016



MAGNETIC BASE DRILLING MACHINES

Magnetic Base Drilling Machines	6
Magnetic Base Drill Accessories	16
Cutting Fluid	22



CUTTING TOOLS

Annular Cutters	25
- H.S.S. Cutters	26
- T.C.T. Cutters	40
- T.C.T. Rail Cutters	45
Weldon Shank Cutting Tools	45
- Countersinks	45
- Twist Drills	45
- Centurail	46
Combination Drill Tap	46
Sheet Metal Cutters	47
Drill Bits	48
Bi - Metal Holesaws	52
T.C.T. Holesaws	56
Step Drills	62
Countersinks	63
Carbide Burrs	64
Hand Deburring Tools	69
Adjustable Hand Reamers	70
Tap Wrenches	71
Button Die Holders	71



CLAMPS

Forged Steel Clamps	75
Toolmakers Parallel Clamps	81
Woodworkers Parallel Clamps	81
Cast Iron Clamps	82
Multi Purpose Clamps	83
Locking Clamps & Pliers	84
Sash Cramps	85
Toggle Clamps	86



ENGINEER'S TOOLS

Set Up Tools	92
Marking Tools	99
Measuring Tools	100

ENGINEER'S TOOLS (CONTINUED)

Precision Measuring Tools	106
Machine Tool Accessories	111
Machine Vises Precision	113
Premium Drill Press Vises	116
General Purpose Drill Press Vises	117
Bench Vises	118
Hobby Vises	119
Punches	120
Chisels & Bolsters	126
Tweezers	127
Wheel Dressers	127
LED Lights	128



SHARPENING MACHINES

Drill Bit Sharpeners - KEF	131
Knife Sharpeners - Worksharp	132
Drill Bit Sharpeners - Drill Doctor	140
Drill Bit Sharpeners - Darex	142
Annular Cutter Sharpeners - Holemaker	145



METAL CUTTING SAWS

Metal Cutting Saws - MACC	148
Metal Cutting Saws - Trademaster	157
Metal Cutting Saws - Steelmax	157
Roller Stands & Conveyors	171
Coldsaw Blades	172
Bandsaw Blades	174
T.C.T. Saw Blades	175



DRILLING MACHINES

Drillmate	177
Vacforce 2000	177
Drilling Machines - Belt Drive	178
Drilling Machines - Geared Head	180



WELDING CARRIAGES & BEVELLING MACHINES

Plate Beveling Machines	184
Pipe Beveling Machines	188
Welding Carriages	193



201

PUNCHES & SHEARS

Manual Shears	202
Manual Punches	202
Hydraulic Punches	203



206

GRINDING MACHINES

Bench Grinders	207
Belt Grinders	208
Pipe Notchers	209

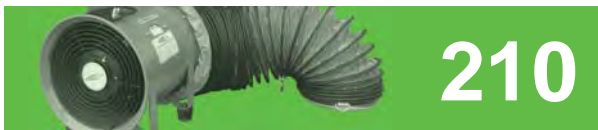

210

FANS & VENTILATORS

Industrial Fans	211
Ventilators	212



214

WORKSHOP STORAGE

Parts Cabinets	215
Parts Bins	219
Workshop Shelving	221
Tool Carts	223



224

M7 AIR TOOLS

Impact Wrenches	226
Angle Drive Impact Ratchets	232
Ratchet Wrenches	233
Hydraulic Rivet Nut Tools	234
Rivet Nut Tools	235
Tappers	235
Hydraulic Riveters	236
Riveter Adaptors	238
Rivet Nut Adaptors	238
Sheet Metal Cutters	239
Nailers	240
Staplers	241
Angle Grinders	242
Cut Off Tools	244
Straight Grinders	245
Die Grinders	246

M7 AIR TOOLS (CONTINUED)

Engraving Pen	248
Buffer	249
Drills	250
Screwdrivers	252
Punch & Flange Tool	253
Polishers	254
Sanders	255
Belt Sanders	258
Flux Chipper	258
Needle Scalars	259
Air Hammers	260
Grease Guns	262
Automotive Tools	262
Alr Brush Set	267
Air Tool Accessories	267
Impact Sockets	270
Impact Socket Accessories	288
Impact Socket Sets	290



293

NPK AIR TOOLS

Impact Wrenches	294
Drills	298
Die Grinders	300
Straight & CNS Grinders	301
Angle Grinders	302
Sanders	303
Chipping Hammers	304
New Kelens	304
Flux Scaling Hammers	305
Auto Chiselers	305
Sand Rammers	306
Hoists	307
Pneumatic Tools	308



310

PNEUMATIC EQUIPMENT

Spray Equipment	311
Suction Feed Guns	311
Gravity Feed Guns	312
Touch Up Guns	313
Pressure Pot Outfits	313
Air Blow Guns - M7	314
Pro Series Air Blow Guns - Groz	316
Filters & Regulators	320
Air Line Couplers	323
Air Line Manifolds	324
Air Hoses & Accessories	326
Push Fit Fittings	328

Magnetic Base Drilling Machines

Cutting Tools

Clamps

Engineer's Tools

Sharpening Machines

Metal Cutting Saws

Drilling Machines

Bevelling Machines & Welding Carriages

Punches & Shears

Grinding Machines

Fans & Ventilators

Workshop Storage

M7 Airtools

NPK Airtools

Pneumatic Products



Magnetic Base Drilling Machines

Magnetic Base Drilling Machines	6
Magnetic Base Drill Accessories	16
Cutting Fluid	22

Magnetic Base Drilling Machines Australia's most comprehensive range!

With our wide range of machine styles, sizes and designs,
there is a Holemaker machine to suit **every application!**

- Reliable and durable European made machines
- Over 20 different models of magnetic drilling machines, stocked in Australia!
- Over 25 years of development



MACHINE SELECTION GUIDE

	Model	Cutter Capacity	Tooling Capacity	Morse Taper	Weight	Stroke	Pg #
Cutting Tools	 Holemaker PRO 35	35mm Diameter 52mm Depth	12mm Drill Bit 40mm Countersink		10.0kg	70mm	7
Clamps	 Holemaker PRO 35 AUTO	35mm Diameter 52mm Depth	12mm Drill Bit 40mm Countersink		13.5kg	70mm	7
Engineer's Tools	 Holemaker PRO 40 PRO 40 QG PRO 40 GR	40mm Diameter 52mm Depth	13mm Drill Bit 40mm Countersink		12.5kg	124mm	8
Sharpening Machines	 Holemaker 40 AD	40mm Diameter 25mm Depth	12mm Drill Bit 40mm Countersink		11.1kg	40mm	9
Metal Cutting Saws	 Holemaker PRO 50 PRO 50 QG	52mm Diameter 52mm Depth	23mm Drill Bit 55mm Countersink	#2 Morse Taper	16.5kg	153mm	9
Drilling Machines	 Holemaker PRO 50 D	52mm Diameter 75mm Depth	23mm Drill Bit 55mm Countersink	#2 Morse Taper	16.5kg	153mm	9
Bevelling Machines & Welding Carriages	 Holemaker PRO 75 PRO 75 SR	75mm Diameter 110mm Depth	32mm Drill Bit 63mm Countersink M24 Tapping	#3 Morse Taper	27.0kg	214mm	10
Punches & Shears	 Holemaker PRO 110	110mm Diameter 110mm Depth	47mm Drill Bit 63mm Countersink M30 Tapping	#4 Morse Taper	31.0kg	214mm	11
Grinding Machines	 Holemaker MAX 2X2	52mm Diameter 52mm Depth	23mm Drill Bit 55mm Countersink	#2 Morse Taper	17.0kg	100mm	12
	 Holemaker MAX 3X3 MAX 3X3SB	75mm Diameter 75mm Depth	32mm Drill Bit 63mm Countersink M24 Tapping	#3 Morse Taper	28.0kg	215mm	12
Fans & Ventilators	 Holemaker MAX 4X4	110mm Diameter 100mm Depth	40mm Drill Bit 63mm Countersink M30 Tapping	#3 Morse Taper	33.0kg	215mm	13
Workshop Storage	 Holemaker TAP 50	200mm Diameter 250mm Depth	55mm Drill Bit 80mm Countersink M52 Tapping	#5 Morse Taper	53.0kg	265mm	14
M7 Airtools	 Holemaker HMP35AD HMP35AD-ATEX	35mm Diameter 25mm Depth	12mm Drill Bit		13.0kg	39mm	14
NPK Airtools	 Holemaker HMP45	45mm Diameter 52mm Depth	23mm Drill Bit 40mm Countersink	#2 Morse Taper	19.0kg	150mm	14
	 Holemaker PRO 200A ATEX	200mm Diameter 52mm Depth	52mm Drill Bit 80mm Countersink M52 Tapping	#5 Morse Taper	130kg	400mm	14
Pneumatic Products	 Holemaker PRO 200H ATEX	200mm Diameter 52mm Depth	52mm Drill Bit 80mm Countersink M52 Tapping	#5 Morse Taper	130kg	400mm	14

HOLEMAKER PRO 35 QUALITY, COMPACT & ROBUST FULLY FEATURED MACHINE



The Holemaker PRO 35 is a high quality, compact and robust, fully featured machine. Weighing in at just 10kg, this machine is ideal for those on-site and overhead tasks, whilst the solid, robust construction means the HMPRO35 is perfect for everyday manufacturing type applications.



The 35mm diameter and 52mm depth cutting capacity will suffice for most general holemaking requirements. Other standard features include a gravity feed coolant system with a magnetically attached coolant bottle, which can be easily removed and attached to the work piece, allowing coolant feed whilst drilling in horizontal applications. The feed handles can be placed on either the left or right hand side, providing further versatility when using this compact machine in tight positions. Dual rail slide system provides rigidity and eliminates the need for gib adjustments. The well designed cutter guard system is easy to use and practical.

*12mm twist drill capacity using Weldon Shank twist drill bits.

OPTIONAL ACCESSORIES & CONSUMABLES

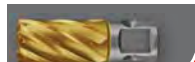

Holemaker Cutters - pg25

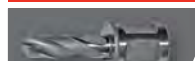

Weldon Shank Drills - pg46



M7 Spring Balancer -pg268

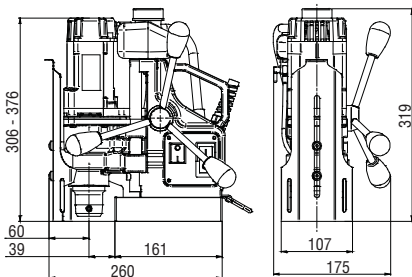

HOLEMAKER PRO 35 AUTO QUALITY, COMPACT & ROBUST FULLY FEATURED MACHINE



The Holemaker PRO 35 AUTO is equipped with many advanced systems & is an ideal cost saving solution for drilling a large number of holes with diameters up to 35mm and maximum depth up to 52mm.



Superior features of the Holemaker PRO 35 AUTO drilling machine include:

- Compact, rigid design with ultra-light weight of 13.5 kg
- Perfect combination of spindle speeds and torque reduces cycle times for both TCT and HSS cutters
- Smart control systems for excellent performance and operator's safety
- Dual rail slide system ensures extraordinary rigidity and maintenance free operation
- Integrated cutter guard
- Large capacity coolant tank



OPTIONAL ACCESSORIES & CONSUMABLES

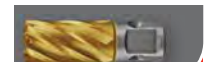

Holemaker Cutters - pg25

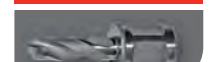

Weldon Shank Drills - pg46



M7 Spring Balancer -pg268

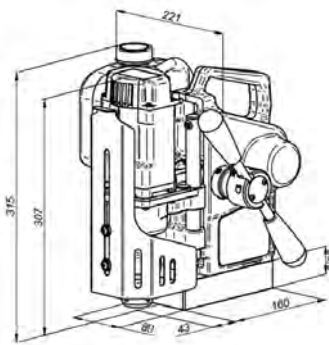

Part No.	HMPRO35
Capacity (Diameter)	35mm
Capacity (Depth)	52mm
Motor Power	920 watt
Input Power	1000 watt Single Phase 240V
Speed	350rpm
Weight	10.0kg
Magnetic Dead Lift	9500Nm On 25mm Steel Plate
Stroke	70mm
Height (min / max)	306 / 376mm
Through Spindle Coolant System	
Smart Magnet Technology To Ensure Sufficient Magnetic Adhesion	
Supplied In Plastic Carry Case With Cutter Guard & Safety Strap	

Part No.	HMPRO35AUTO
Capacity (Diameter)	35mm
Capacity (Depth)	52mm
Motor Power	920 watt
Input Power	1000 watt Single Phase 240V
Speed	350rpm
Weight	13.5kg
Magnetic Dead Lift	9500Nm On 25mm Steel Plate
Stroke	70mm
Height (min / max)	306 / 376mm
Through Spindle Coolant System	
Smart Magnet Technology To Ensure Sufficient Magnetic Adhesion	
Supplied In Metal Carry Case With Cutter Guard & Safety Strap	

HOLEMAKER PRO 36 AD ULTRA LOW PROFILE MAGNETIC BASE DRILL



The PRO 36 AD is an ultra-low profile mag drill, that fits in the tightest of spots. Perfect solution for any applications in confined spaces, where typical mag drills are too large. A powerful motor and strong electromagnetic base enable drilling of holes up to 36 mm diameter to a depth of up to 30 mm (1-3/16").

PRO-36 AD accepts both TCT and HSS cutters as well as twist drill drills with 19,05 mm (3/4") Weldon shank.



OPTIONAL ACCESSORIES & CONSUMABLES



Holemaker Cutters - pg25



Taper Shank Drills



M7 Spring Balancer -pg268

Features

- Ultra-low profile mag drill of 176 mm height only
- Extremely low weight of just 9.5 kg (21 lbs)
- Milling capacity up to 36 mm (1-7/16")
- Accepts also twist drills with 19,05 mm (3/4") Weldon shank
- Stroke – 39 mm
- Integrated swarf guard
- Detachable feed lever (feat. ratchet) can be fixed from either side
- Lifting handle for easy transportation
- Cooling with a bottle

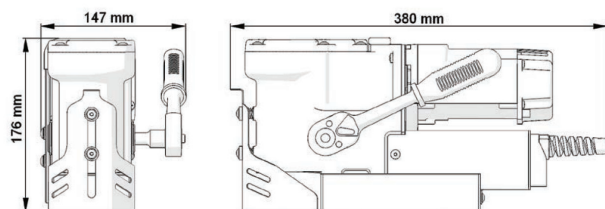

Part No.	HMPRO36AD
Capacity (Diameter)	36mm
Capacity (Depth)	30mm
Capacity (Twist Drill)	12mm
Motor Power	920 watt
Input Power	1000 watt Single Phase 240V
Speed	370rpm
Weight	9.5kg
Magnetic Dead Lift	8900Nm On 25mm Steel Plate
Stroke	36mm
Height (min / max)	176mm Constant Working Height
Through Spindle Coolant System	
Smart Magnet Technology To Ensure Sufficient Magnetic Adhesion	
Supplied In Metal Carry Case With Cutter Guard & Safety Strap	

HOLEMAKER PRO 40 DURABLE & VERSATILE MACHINE



The Holemaker Pro 40 is a highly versatile, durable machine, offering exceptional value for money.

This quality European machine features a 1020 watt industrial motor, powerful dual coil magnet and cutting capacity of 40mm diameter and 52mm depth using Holemaker cutters.

Offered as standard with a grub screw arbor system, which fastens positively onto Holemaker cutters. A Quick Grip Arbor System is available as an option.



The through cutter coolant feed, with an external side mounted gravity feed coolant tank ensures smooth fast clean hole cutting.

The feed handles can be placed on either the left or right hand side, for increased versatility.

An optional drill chuck system is available (SA70102), giving the ability to use twist drills up to 13mm diameter. The drill chuck system replaces the entire weldon arbor, allowing the full stroke of the machine to be utilised when using drill bits.

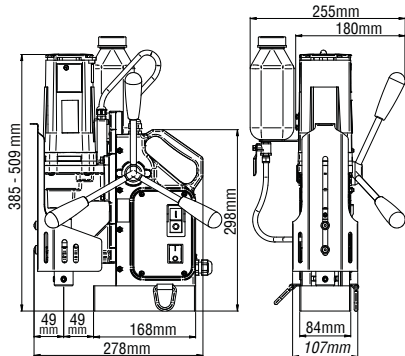

OPTIONAL ACCESSORIES & CONSUMABLES

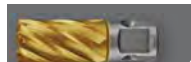

Holemaker Cutters - pg25



Twist Drill Chuck - pg17



M7 Spring Balancer -pg268

Part No.	HMPRO40
Capacity (Diameter)	40mm
Capacity (Depth)	52mm
Capacity (Twist Drill)	13mm
Motor Power	1020 watt
Input Power	1100 watt Single Phase 240V
Speed	440rpm
Weight	12.5kg
Magnetic Dead Lift	10650Nm On 25mm Steel Plate
Stroke	124mm
Height (min / max)	385 / 509mm
Through Spindle Coolant System	
Smart Magnet Technology To Ensure Sufficient Magnetic Adhesion	
Supplied In Metal Carry Case With Cutter Guard & Safety Strap	

HOLEMAKER PRO 40 QG AS PER THE HOLEMAKER PRO 40 WITH QUICK GRIP ARBOR SYSTEM



The Holemaker PRO 40 is available with an optional Quick Grip Arbor System.

This arbor offers a fast, tool-less approach to inserting and removing Holemaker cutters.

The Quick Grip Arbor System is suitable for use with standard Weldon Shank annular cutters with 2 flat sections at 90°, as well as Holemaker universal shank cutters.



Part No.	Description
HMPRO40QG	Holemaker Pro 40 With Quick Grip Arbor

HOLEMAKER PRO 40 GR AS PER THE HOLEMAKER PRO 40 WITH FEED GEAR REDUCTION SYSTEM



The Holemaker Pro 40 is available with Feed Gear Reduction. This unique feature reduces the gearing 2:1 on the down feed which makes for smoother hole cutting and ease of operation.



This feature is highly beneficial when drilling hardened steels such as Bisalloy, wear plate and exotic alloys.

Part No.	Description
HMPRO40GR	Holemaker Pro 40 With Feed Gear Reduction

HOLEMAKER PRO 40 OPTIONAL DRILL CHUCK

An optional drill chuck system is available for the Holemaker Pro 40, as pictured, giving the ability to use twist drills up to 13mm diameter. The drill chuck system replaces the entire Weldon arbor, allowing the full stroke of the machine to be utilised when using drill bits. Suitable for use with Jobber drills up to 10.0mm (see pg48.) Suitable for use with Stub drills up to 13.0mm.



Part No.	Description
SA70102	13mm Drill Chuck & Adaptor To Suit PRO 40

HOLEMAKER 40 ANGLE DRIVE LOW PROFILE ANGLE DRIVE DRILLING MACHINE



The Holemaker 40AD is a low profile angle drive machine providing a constant working height of 181mm. The Holemaker 40AD utilises standard 3/4" shank Holemaker cutters up to 40mm diameter and 25mm depth, ensuring a wide range of cutters is always available. The feed handle can be easily changed to either side or removed for use with a socket wrench on the hex drive, and with the combination of a 181mm constant working height, this machine can work in areas most others cannot. This machine is ideal for working with truck chassis.

The remote pressure feed coolant system, supplies cutting fluid to the centre of the annular cutter even when the machine is positioned in vertical & horizontal positions.

*12mm twist drill capacity using Weldon Shank twist drill bits.

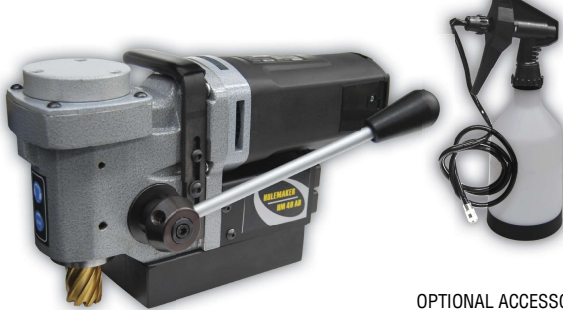

OPTIONAL ACCESSORIES & CONSUMABLES

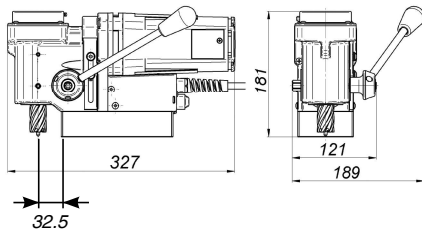

HOLEMAKER PRO 50 #2 MORSE TAPER, DURABLE MULTI-PURPOSE MACHINE



The ability to use Holemaker cutters, No. 2 Morse Taper shank drills & reamers, as well as a drill chuck makes this a very multi-purpose machine. Satisfying most requirements with a capacity of 52mm diameter & 75mm* depth of cut when using Holemaker cutters, and 23mm diameter using taper shank drills or reamers. An industrial 2 speed gearbox and 1260w motor provide a strong hardworking machine. Other standard features include cast iron construction, gravity feed coolant system & left or right hand feed handle operation. The unique semi-automatic gib adjustment system enables simple, fast and always correct fine tuning without any expert knowledge or experience.

Suitable for steel fabrication, engineering workshops & maintenance facilities where a heavy duty versatile machine is highly beneficial.

* Supplied complete with arbor for use with Holemaker cutters up to 52mm depth of cut. Optional arbor to take Holemaker cutters up to 75mm depth of cut is available.

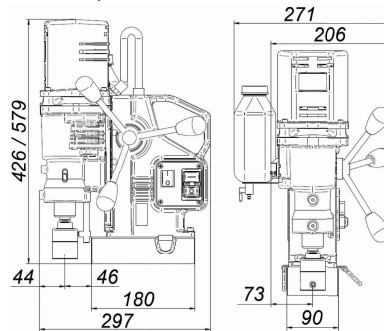

OPTIONAL ACCESSORIES & CONSUMABLES



Part No.	HM40AD
Capacity (Diameter)	40mm
Capacity (Depth)	25mm
Motor Power	1020 watt
Input Power	1100 watt Single Phase 240V
Speed	310rpm
Weight	11.1kg
Stroke	40mm
Magnetic Dead Lift	9500Nm On 25mm Steel Plate
Height (min / max)	181mm Constant Working Height

Through Spindle Coolant System

Smart Magnet Technology To Ensure Sufficient Magnetic Adhesion

Supplied In Metal Carry Case With Cutter Guard & Safety Strap

Part No.	HMPRO50 (With Grub Screw Arbor)
Part No.	HMPRO50QG (With Quick Grip Arbor)
Part No.	HMPRO50D (With 75mm Depth Capacity)
Capacity (Diameter)	52mm
Capacity (Depth)	75mm
Capacity (Twist Drill)	#2 Morse Taper 23mm
Motor Power	1260 watt
Input Power	1340 watt Single Phase 240V
Speed	2 speed 200 / 400rpm
Weight	16.5kg
Magnetic Dead Lift	12000Nm On 25mm Steel Plate
Stroke	153mm
Height (min / max)	426mm / 579mm

Through Spindle Coolant System

Smart Magnet Technology To Ensure Sufficient Magnetic Adhesion

Supplied In Metal Carry Case With Cutter Guard & Safety Strap

HOLEMAKER PRO 75 #3 MORSE TAPER VARIABLE SPEED MACHINE



The Holemaker PRO 75 is a versatile, multi-purpose machine, equipped with a No. 3 Morse Taper spindle. The 2 speed gearbox with electronic variable speed, Electronic Speed Stabilization System (ESSS), and motor soft start feature makes this machine ideal for tapping up to M24. With a large cutting capacity of 75mm diameter and 110mm depth using Holemaker cutters, this machine will suffice for most holemaking requirements. Other standard features include gravity feed coolant system & left or right hand feed handle operation. The unique semi-automatic gib adjustment system enables simple, fast and always correct fine tuning without any expert knowledge or experience.

Supplied complete with arbor for use with Holemaker cutters up to 75mm depth of cut. Optional arbor to take Holemaker cutters up to 110mm depth of cut is available.

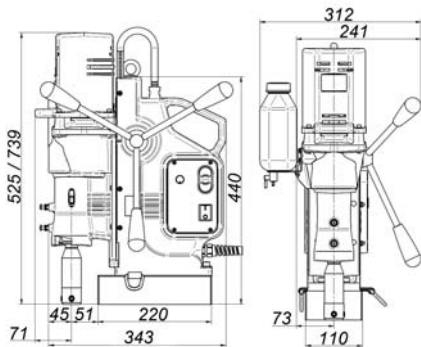

OPTIONAL ACCESSORIES & CONSUMABLES



HOLEMAKER PRO 75 SR AS PER PRO 75, WITH ADDITIONAL REVERSE AND SWIVEL BASE



The Holemaker Pro 75SR is as per the standard Holemaker Pro 75, but with the two additions of a swivel base system and jog reverse function. The swivel base system makes it easier to move the machine into the correct position for drilling.

Once the drill has been fixed to the workpiece with the magnet, it can then be moved back and forward 15mm, or swivelled left and right 30°, and is then fastened into position with one socket head bolt.

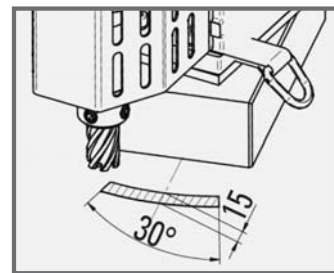

The combination of the variable speed, jog reverse function, and the swivel base system, makes this a very versatile machine that is ideal for tapping.

Part No.	Description
HMPRO75SR	Holemaker Pro 75 - With Swivel Base & Reverse

Tapping WITH THE HOLEMAKER PRO 75

The Holemaker Pro 75 makes difficult tapping jobs run smooth and easy. With the optional tapping head fitted, the Pro 75 will tap a maximum M20.

Features

- Protection against tap breakage ensured by an ultra sensitive and smooth multi-position operating ball-clutch.
- Forward and reverse ball drive design transmits rotational power to the tap and disengages smoothly and silently.
- Axial float ensures smooth tapping and better thread profile.
- Cushioned drive incorporating compression and extension, eliminates the possibility of cross threading during the tapping process, and ensures clean and accurate threads.
- A planetary gear reversing mechanism transmits smooth positive reverse to the tap retraction and it retracts 75% faster than it enters.
- Accurate depth control by means of it's precise neutral mechanism.



Specifications

- 20mm maximum tapping capacity
- 130mm stroke with tapping head fitted
- 168mm maximum length of tap

Part No.	Description
SPTH103	8-20mm Tapping Head With #3 MT

Part No.	HMPRO75
Capacity (Diameter)	75mm
Capacity (Depth)	110mm
Capacity (Twist Drill)	#3 Morse Taper 32mm
Motor Power	1650 watt
Input Power	1800 watt Single Phase 240V
Gearbox	2 Speed Gearbox With Electronic Variable Speed And Motor Soft Start Feature 80-160; 210-420rpm
Weight	27.0kg
Magnetic Dead Lift	19500Nm On 25mm Steel Plate
Stroke	214mm
Height (min / max)	525mm / 739mm
Through Spindle Coolant System	
Smart Magnet Technology To Ensure Sufficient Magnetic Adhesion	
Supplied In Metal Carry Case With Cutter Guard & Safety Strap	

HOLEMAKER PRO 110 LARGE CAPACITY #4 MORSE TAPER HEAVY DUTY MACHINE



The Holemaker PRO 110 is an extra heavy duty, large capacity machine capable of producing burr-free holes up to 110mm diameter by 110mm depth. 1650w motor with 4-speed mechanical gearbox produces superb torque through gear reduction in low speeds. No. 4 Morse Taper spindle bore for use with taper shank drills, tapping head (M30 Capacity) and taper shank reamers.



Supplied complete with side mounted coolant system and arbor for use with 3/4" shank Holemaker cutters up to 75mm diameter and 75mm depth of cut. Optional arbor to take 1-1/4" shank cutters up to 110mm diameter and 110mm depth. 1100ml pressure feed coolant bottle available, recommended for use with large diameter and depth hole drilling.

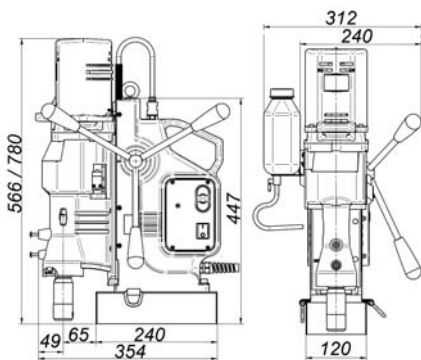

OPTIONAL ACCESSORIES & CONSUMABLES



Holemaker Cutters - pg25



Taper Shank Drills



Twist Drill Chuck - pg17



M7 Spring Balancer -pg268

Large Holes WITH THE HOLEMAKER PRO 110

Holemaker annular cutters are available up to 75mm diameter with a standard 3/4" Weldon shank.

61mm to 150mm diameter cutters are available with a 1-1/4" shank, to help increase the strength of the cutter.

The Holemaker Pro 110 is supplied as standard with No. 4 Morse Taper arbor for use with 3/4" shank Holemaker cutters up to 75mm diameter and 75mm depth of cut.

Alternatively the Pro 110 can be ordered with a number of different No. 4 Morse Taper arbors, depending on your specific job requirements.



Part No.	Morse Taper	Maximum Depth Of Cut	To Suit Shank Size
SPPR011011	#4 MT	50mm	3/4"
SAIA4S-100	#4 MT	110mm	3/4"
SPPR011011B	#4 MT	50mm	1-1/4"
SAIA4SW-100	#4 MT	110mm	1-1/4"

For example, when drilling a 82mm diameter hole through 100mm solid steel, arbor part# SAIA4SW-100 would be used with a Holemaker Maxi-Cut Cutter part# MAX100-82B (see page 43)

When drilling large diameter or deep holes with the Holemaker Pro 110, the optional 1100ml pressure feed coolant tank is highly beneficial.

The pressure feed tank will increase the coolant flow to the centre of the cut, and will also allow for larger cuts to be completed, without having to re-fill the coolant tank during the cutting process.



Part No.	Description
SA-WPB	1100ml Pressure Feed Coolant Bottle

Part No.	HMPRO110
Capacity (Diameter)	110mm
Capacity (Depth)	110mm
Capacity (Twist Drill)	#4 Morse Taper 47mm
Motor Power	1650 watt
Input Power	1800 watt Single Phase 240V
Gearbox	4 Speed Heavy Duty Mechanical Gearbox 85 / 135 / 160 / 250rpm
Weight	31.0kg
Magnetic Dead Lift	22000Nm On 25mm Steel Plate
Stroke	214mm
Height (min / max)	566mm / 780mm
Through Spindle Coolant System	
Smart Magnet Technology To Ensure Sufficient Magnetic Adhesion	
Supplied In Metal Carry Case With Cutter Guard & Safety Strap	

HOLEMAKER MAX 2X2 #2 MORSE TAPER, VERSATILE MULTI-PURPOSE MACHINE



Versatility is the hallmark of this machine. Holes up to 52mm diameter by 52mm depth can be produced quickly and efficiently using Holemaker cutters, and with the No. 2 Morse Taper it is just at home with a drill chuck and arbor or taper shank drills and reamers up to 23mm. Featuring a heavy duty 2 speed gear box and side mounted coolant system. This machine is perfectly suited to engineering workshops and maintenance facilities, where its versatility is most valuable.



OPTIONAL ACCESSORIES & CONSUMABLES



Holemaker Cutters - pg25



Taper Shank Drills



Twist Drill Chuck - pg17



M7 Spring Balancer -pg268

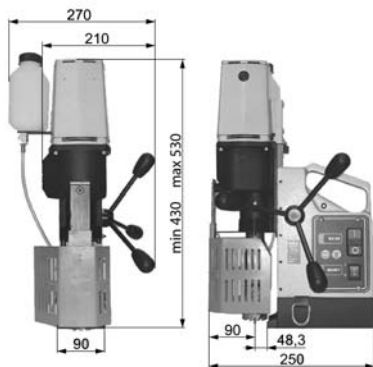

HOLEMAKER MAX 3X3 #3 MORSE TAPER VARIABLE SPEED MACHINE



No. 3 Morse Taper drilling machine accepts Holemaker cutters, No. 3 Morse Taper drill bits, tapping head & reamers.

Two speed gearbox, electronic variable speed, soft start, and jog reverse function, makes this machine ideal for tapping.

75mm diameter x 75mm depth Holemaker cutter capacity. Side mounted coolant system. Optional 1100ml pressure feed coolant bottle available.



OPTIONAL ACCESSORIES & CONSUMABLES



Holemaker Cutters - pg25



Taper Shank Drills



Twist Drill Chuck - pg17



Tapping Head - pg20



M7 Spring Balancer -pg268

The Holemaker MAX 3X3 is also available with a swivel base system fitted, which allows 30° of movement left and right, and 15mm back and forward.

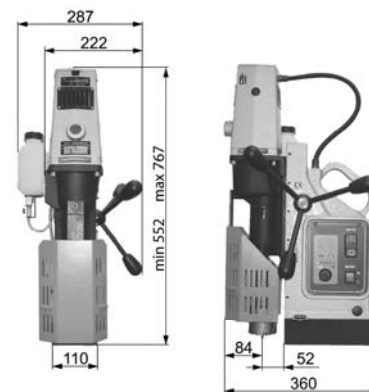

Part No.	SM2X2-MT2
Capacity (Diameter)	52mm
Capacity (Depth)	52mm
Capacity (Twist Drill)	#2 Morse Taper 23mm
Motor Power	1260 watt
Input Power	1340 watt single phase 240V
Gearbox	2 speed 210 / 420rpm
Weight	17.0kg
Stroke	100mm
Magnetic Dead Lift	12000Nm On 25mm Steel Plate
Height (min / max)	430mm / 530mm
Through Spindle Coolant System	
Smart Magnet Technology To Ensure Sufficient Magnetic Adhesion	
Supplied In Metal Carry Case With Cutter Guard & Safety Strap	

Part No.	SM3X3
Part No.	SM3X3SB (With Swivel Base Fitted)
Capacity (Diameter)	75mm
Capacity (Depth)	75mm
Capacity (Twist Drill)	#3 Morse Taper 32mm
Motor Power	1460 watt
Input Power	1570 watt Single Phase 240V
Gearbox	2 Speed Gearbox With Electronic Variable Speed And Motor Soft Start Feature 80-160; 160-320rpm
Weight	28.0kg
Stroke	215mm
Magnetic Dead Lift	19500Nm On 25mm Steel Plate
Height (min / max)	552mm / 767mm
Through Spindle Coolant System	
Smart Magnet Technology To Ensure Sufficient Magnetic Adhesion	
Supplied In Metal Carry Case With Cutter Guard & Safety Strap	

HOLEMAKER MAX 4X4 #3 MORSE TAPER LARGE CAPACITY MACHINE



The SM4X4 is capable of producing burr-free holes up to 110mm diameter and 100mm depth. 1800w motor with 4-speed mechanical gearbox produces superb torque through gear reduction in low speeds. No. 3 Morse Taper spindle bore for use with taper shank drills. Supplied complete with side mounted coolant system and arbor for use with 3/4" shank Holemaker cutters up to 75mm diameter by 75mm depth of cut. Optional arbor to take 1-1/4" shank cutters up to 110mm diameter by 100mm depth, 1100ml pressure feed coolant bottle available.

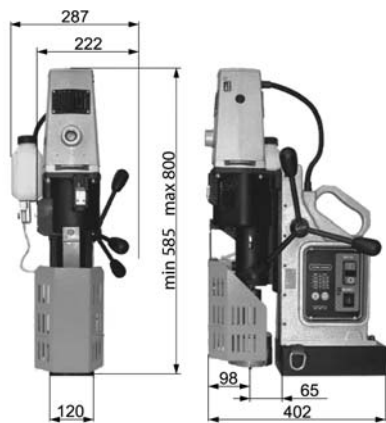

OPTIONAL ACCESSORIES & CONSUMABLES



HOLEMAKER TAP 50 #5 MORSE TAPER LARGE CAPACITY MACHINE



The TAP 50 is a portable magnetic drilling machine with 200mm diameter drilling and M52 tapping capacity (with optional tapping head) TAP 50 has a 3.0kW single phase 240V motor. The spindle bore is No.5 Morse Taper. The TAP 50 is designed for special and challenging applications that no other portable magnetic drill has been able to solve before.

- Feed handles can be placed on the left or right sides of the machine
- Reversible
- Heavy duty dual rail slides provide rigidity and quick movement



Part No.	HMTAP50
Capacity (Diameter)	200mm
Capacity (Depth)	250mm
Capacity (Tapping)	52mm
Capacity (Twist Drill)	52mm
Motor Power	3000 watt
Input Power	Single Phase 240V
Gearbox	2 Speed Variable Gearbox 20-40 / 45-110
Weight	53.0kg
Stroke	265mm
Height (min / max)	710mm / 975mm

Part No.	SM4X4
Capacity (Diameter)	110mm
Capacity (Depth)	100mm
Capacity (Twist Drill)	#3 Morse Taper 32mm
Motor Power	1800 watt
Input Power	1990 watt Single Phase 240V
Gearbox	4 Speed Heavy Duty Gearbox 100 / 150 / 200 / 310rpm
Weight	32.0kg
Stroke	215mm
Magnetic Dead Lift	22000Nm On 25mm Steel Plate
Height (min / max)	585mm / 800mm
Through Spindle Coolant System	
Smart Magnet Technology To Ensure Sufficient Magnetic Adhesion	
Supplied In Metal Carry Case With Cutter Guard & Safety Strap	

Tapping WITH THE HOLEMAKER TAP 50

With a variable speed gearbox going as low as 20rpm and reversing function, the Holemaker TAP 50 machine is well suited to tapping a large range of diameters. Used with the optional quick change chuck and tapping system (see pages 20 & 21) tapped holes can be achieved with ease.

The QASB tap collet, with factory set safety clutch to suit the specific tap size, clicks into the KTX tap adaptor that is held by the quick change master holder - providing for fast interchange of drill and tap sizes with no tooling required.



HOLEMAKER 35 PNEUMATIC PNEUMATIC POWERED LOW PROFILE ANGLE DRIVE MACHINE



The HMP35AD is a small portable pneumatic drilling machine which allows holes to be drilled up to 35mm diameter in places with restricted space, using standard 3/4" Weldon Shank cutters. This machine is the lowest height pneumatic magnetic drill currently available on the world market. The combination of pneumatic drive and permanent magnetic base eliminate the need for electric power supply thus making this machine an ideal solution in many hazardous environments such as oil drilling platforms, mining industry, shipbuilding or petrochemical industry.

*12mm twist drill capacity using Weldon Shank twist drill bits.

HMP 35 AD

The compressed-air motor used in the HMP35AD drill is certified ATEX II2G/D C IIC T6;T4 and meets the requirements for use in areas with a risk of explosion.

HMP 35 AD-ATEX

Both the machine and the body of the HMP35AD-ATEX drill is certified ATEX II2G/D C IIC T6;T4 and meets the requirements for use in areas with a risk of explosion.



OPTIONAL ACCESSORIES & CONSUMABLES



Holemaker Cutters - pg25



Weldon Shank Drills - pg46



M7 Spring Balancer -pg268

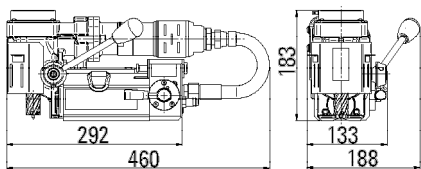

Part No.	HMP35AD
Part No.	HMP35AD-ATEX
Capacity (Diameter)	35mm
Capacity (Depth)	25mm
Motor	800 watt pneumatic, 1400L/min
Weight	13.0kg
Height	183mm Constant Working Height
Stroke	39mm
Magnetic Dead Lift	6500Nm On 25mm Steel Plate
Through Spindle Coolant System	
Supplied In Metal Carry Case With Cutter Guard & Safety Strap	

HOLEMAKER 45 PNEUMATIC #2 MORSE TAPER, VERSATILE MULTI-PURPOSE MACHINE



The HMP45 is a compact portable pneumatic powered drilling machine which allows hole cutting up to 45mm diameter and 52mm depth using Holemaker cutters. The No. 2 Morse Taper spindle allows a wide range of tooling to be used with the machine. The combination of pneumatic drive and permanent magnetic base eliminate the need for electric power supply thus making this machine an ideal solution in many hazardous environments such as oil drilling platforms, mining industry, shipbuilding or petrochemical industry.



HMP 45

The compressed-air motor used in the HMP45 drill is certified ATEX II2G/D C IIC T6;T4 and meets the requirements for use in areas with a risk of explosion.

HMP 45-ATEX

Both the machine and the body of the HMP45-ATEX drill is certified ATEX II2G/D C IIC T6;T4 and meets the requirements for use in areas with a risk of explosion.

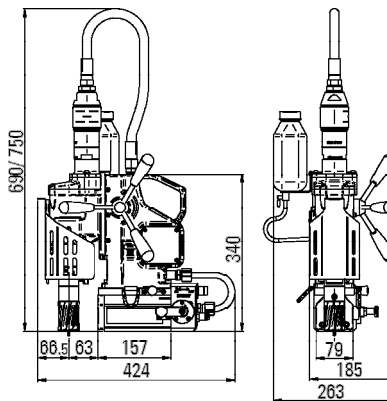

OPTIONAL ACCESSORIES & CONSUMABLES



Holemaker Cutters - pg25

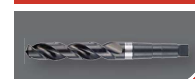

Taper Shank Drills



Twist Drill Chuck - pg17



M7 Spring Balancer -pg268

Part No.	HMP45
Part No.	HMP45-ATEX
Capacity (Diameter)	45mm
Capacity (Depth)	52mm
Capacity (Twist Drill)	#2 Morse Taper 23mm
Motor Power	800 watt Pneumatic, 1400L/min
Speed	2 Speed 190 / 290rpm
Weight	19.0kg
Magnetic Dead Lift	7500Nm On 25mm Steel Plate
Height (min / max)	690mm / 750mm
Stroke	150mm
Through Spindle Coolant System	
Supplied In Metal Carry Case With Cutter Guard & Safety Strap	

HOLEMAKER PNEUMATIC PRO 200A ATEX #5 MORSE TAPER



The PRO200A is a new pneumatic portable magnetic drilling machine with 200mm diameter drilling and M52 tapping capacity. The spindle bore is No.5 Morse Taper and the drill chuck is 1-1/4" Weldon. The PRO200A is a robust design built with modular construction and can be handled by a single operator.

Features:

- 2 speeds - ideal for drilling and tapping
- Integrated air processing module
- 2 x 14700Nm magnetic adhesion force
- Adaptive magnets, can work on curved or flat surfaces
- Integrated swarf guard
- Reverse



Both the machine and the body of the PRO200A drill is certified ATEX II2G/D C IIC T6;T4 and meets the requirements for use in areas with a risk of explosion.

Part No.	PRO200A
Capacity (Diameter)	200mm
Capacity (Tapping)	52mm
Motor Power	2000 Watt
Gearbox	2 Speed Gearbox Reversible 20 / 80rpm
Weight	130kg
Stroke	400mm
Magnetic Dead Lift	2 x 14700Nm

HOLEMAKER HYDRAULIC PRO 200H ATEX #5 MORSE TAPER



The PRO200H is a new hydraulic portable magnetic drilling machine with 200mm diameter drilling and M52 tapping capacity. The spindle bore is No.5 Morse Taper and the drill chuck is 1-1/4" Weldon.

Features:

- 2 speeds - ideal for drilling and tapping
- Detachable parts - can be delivered and assembled on site
- Powerful drive
- Robust design
- Adaptive magnets - work on flat and curved surfaces
- Low noise
- Optional hydraulic pack or can be connected to existing lines
- Runs on hydraulic oil.
- Integrated swarf guard
- Reverse
- Magnet adhesion force - 2 x 14700Nm



Both the machine and the body of the PRO200H drill is certified ATEX II2G/D C IIC T6;T4 and meets the requirements for use in areas with a risk of explosion.

Part No.	PRO200H
Capacity (Diameter)	200mm
Capacity (Tapping)	52mm
Motor Power	2000 Watt
Gearbox	2 Speed Gearbox Reversible 22 / 90rpm
Weight	130kg
Stroke	400mm
Magnetic Dead Lift	2 x 14700Nm

DRILL ACCESSORIES

INDUSTRIAL ARBORS

These arbors are designed to adapt conventional machines eg. drill presses, lathes, milling machines and others to accept Holemaker annular cutters. This becomes a very economical alternative to normal methods of drilling or boring large diameter or deep holes. By adding an extension arbor and long series annular cutter to your industrial arbor, you can achieve depths of up to 320mm in hollow section steel. Time savings in excess of 40% over normal drilling methods are not unusual.

- Adapt your drill press or lathe to use Holemaker annular cutters
- Time savings in excess of 40%
- Economical compared with conventional methods
- Large cutting capacity up to 150mm diameter



Part No.	Morse Taper	Maximum Depth Of Cut	To Suit Shank Size
SAIA2S	#2 MT	50mm	3/4"
SAIA2S-75	#2 MT	75mm	3/4"
SAIA3S	#3 MT	50mm	3/4"
SAIA3S-100	#3 MT	110mm	3/4"
SAIA3SW	#3 MT	50mm	1-1/4"
SAIA3SW-100	#3 MT	110mm	1-1/4"
SAIA4S	#4 MT	50mm	3/4"
SAIA4S-100	#4 MT	110mm	3/4"
SAIA4SW	#4 MT	50mm	1-1/4"
SAIA4SW-100	#4 MT	110mm	1-1/4"
SAIA5SW	#5 MT	50mm	1-1/4"
SAIA5SW-100	#5 MT	110mm	1-1/4"

Our large range of magnetic base drilling machine accessories enables the most diverse range of jobs to be completed successfully.

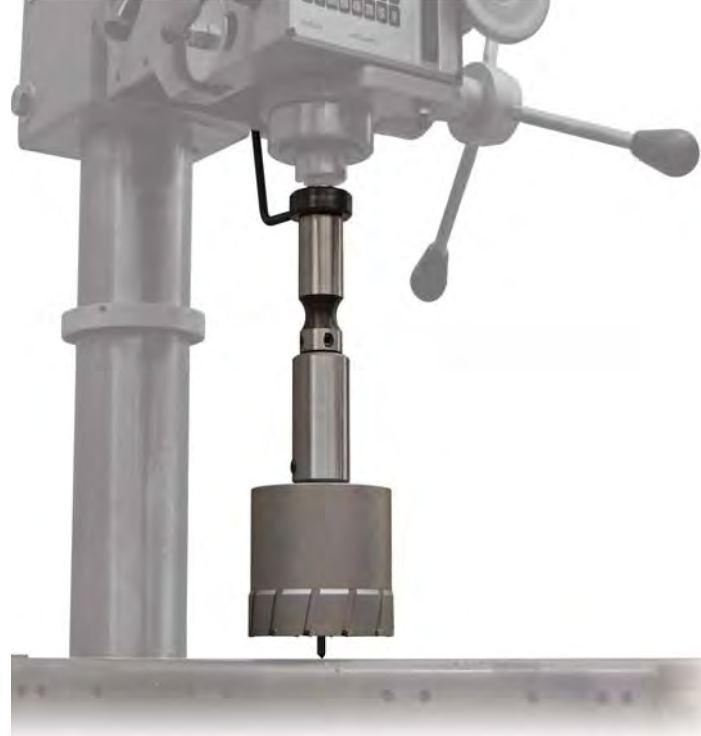

EXTENSION ARBORS

- An extension arbor allows greater depths to be reached with your Holemaker cutters



Part No.	Extension Length	Pilot Pin Diameter	Shank Diameter	Minimum Cutter Diameter
SAE025-6	25mm	6.34mm	3/4"	36mm
SAE050-6	50mm	6.34mm	3/4"	36mm
SAE075-6	75mm	6.34mm	3/4"	36mm
SAE100-6	100mm	6.34mm	3/4"	36mm
SAE025-8	25mm	8mm	3/4"	36mm
SAE050-8	50mm	8mm	3/4"	36mm
SAE075-8	75mm	8mm	3/4"	36mm
SAE100-8	100mm	8mm	3/4"	36mm
SAE050-8B	50mm	8mm	1-1/4"	50mm
SAE100-8B	100mm	8mm	1-1/4"	50mm

QUICK GRIP INDUSTRIAL ARBORS

These Quick Grip Arbors offer a tool less approach to holding 3/4" Weldon Shank Holemaker cutters in place. Complete with coolant inducer.



Part No.	Morse Taper	Maximum Depth Of Cut	To Suit Shank Size
SAQCA-2MT	#2 MT	50mm	3/4"
SAQCA-3MT	#3 MT	50mm	3/4"

DRILL CHUCKS & ADAPTORS

Complete setup to adapt your Holemaker machine to use twist drill bits.



Part No.	To Suit Machines	Arbor / Adaptor	Capacity
SA70102	HMPRO40	-	13mm
SA20102	HMPRO50 / SM2X2-MT2	#2 MT	13mm
SA3344	HMPRO75 / SM3X3 / SM4X4	#3 MT	19mm
SA4019	HMPRO110	#4 MT	19mm

ADAPTORS

Adapt your magnetic base drilling machine for various applications.



SACA-52HSS



SADCA

Part No.	Description
SADCA	3/4" Male Universal Shank To 1/2" - 20 UNF Male Thread
SACA-52-6	3/4" Male Universal Shank To 3/4" Female Weldon Shank - 6.34mm Pin
SACA-52-8	3/4" Male Universal Shank To 3/4" Female Weldon Shank - 8mm Pin
SAQA-52	3/4" Male Quick In Shank To 3/4" Female Weldon Shank - 6.34mm Pin

FOR CHUCKS, ARBORS, REDUCTION SLEEVES & DRILL DRIFT KEYS SEE PAGE 111 & 112



MAGNETIC CLEAN UP WAND

Ideal for collecting ferrous materials including metal shavings, screws etc.
Stainless steel construction with rubber handle.



Part No.	Description	Length	Diameter
MB-00	Mini Magnetic Wand	240mm	16mm
MB-01	Midi Magnetic Wand	385mm	25mm
MB-30	Maxi Magnetic Wand	1008mm	25mm

MAGNETIC CLEAN UP BROOM

Ideal for collecting ferrous materials including metal shavings, screws etc. off the floor.

- 355mm magnetic surface width
- 385mm overall width



Part No.	Description
MB-15	Magnetic Clean Up Broom

RATCHETING HEX KEY WRENCH

A complete set of standard hex wrenches in one compact tool.
The ratcheting hex key wrench makes tightening or loosening socket head screws easy.



Part No.	Description
RHM001	Hex Key Wrench Metric 1.5 - 6mm
RHS001	Hex Key Wrench Metric 5/64" to 1/4"

VACUUM PAD

Adapt your Holemaker machine for use on non-ferrous materials.

- L: 400mm W: 153mm H: 100mm
- Supply min air: 2.0CFM @ 85psi
- Surface does not have to be smooth, imperfections up to 3.0mm
- Surface holding power is 3383Nm



Part No.	Description
DM110SP	Vac Pad For Use With Magnetic Drill

PIPE ATTACHMENT

Adapt your Holemaker machine to use on pipe.
Can be used on any ferrous and non-ferrous materials.
SAPA-1 : Single chain
SAPA-2 : Double chain

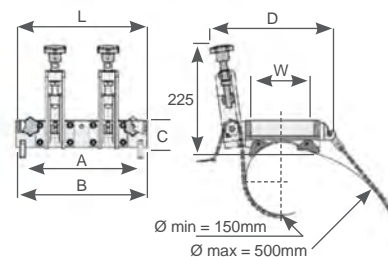
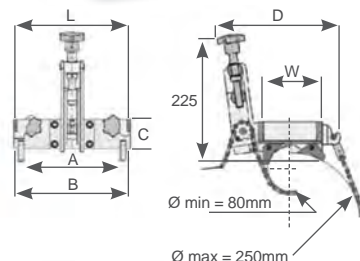

Part No.	Description	A	B	C	D	L	W
SAPA-1	Suit Pipe Ø 80mm To Ø 250mm Maximum Base Dimensions: 95 x 204mm	181	217	52.5	221	205	95
SAPA-2	Suit Pipe Ø 150mm To Ø 500mm Maximum Base Dimensions: 130 x 254mm	234	270	52.5	260	258	130

PILOT PINS

A pilot pin serves three main purposes

- Ejects the slug at the end of the cut
- Provides coolant feed into the centre of the cutter
- Locates the centre of the cut

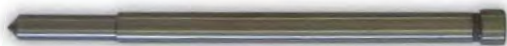

Part No.	Diameter	Annular Cutter Depth Of Cut	Overall Length
SP16001	4.70mm	25mm	77mm
SP16002	4.70mm	50mm	102mm
SP16003	6.34mm	25mm	77mm
SP16004	6.34mm	50mm	102mm
SP16005	6.34mm	75mm	127mm
SP16008	6.34mm	50mm 1-1/4" Shank	133mm
SP16009	6.34mm	100mm - Suit MAX100 (14 - 17mm Ø)	160mm
SP16010	6.34mm	100mm - Suit Extensions Arbors	153mm
SP16011	6.34mm	125mm	188mm
SP16012	6.34mm	150mm	203mm
SP16013	6.34mm	175mm	239mm
SP16015	6.34mm	Suit MAX35 (12 - 17mm Ø)	90mm
SP18025	8mm	25mm	77mm
SP18035	8mm	35mm	90mm
SP18050	8mm	50mm	108mm
SP18075	8mm	75mm	130mm
SP18100	8mm	100mm	160mm
SP18125	8mm	125mm	180mm
SP18150	8mm	150mm	205mm
SP18175	8mm	175mm	230mm
SP18200	8mm	200mm	255mm

2 PIECE PILOT PINS

The depth of cut restrictions for a magnetic base drilling machine using annular cutters is limited by the ability of the machine's arbor to retract the pilot pin within itself.

These two part pilot pins allow the depth of cut capacity to be increased. ie. a machine that is limited to 52mm depth of cut as standard can be increased to 75, 100 or 125mm depth of cut. A depth of cut capacity will still be limited by stroke.



Part No.	Diameter	Annular Cutter Depth Of Cut	Overall Length
SP20001	8mm	75mm	130mm
SP20003	8mm	100mm	158mm
SP20005	8mm	125mm	184mm

PILOT PIN SELECTION CHART

Use chart below to determine the correct pin for use with your extension arbor.

Annular Cutter Depth Of Cut	EXTENSION ARBOR LENGTH			
	25mm	50mm	75mm	100mm
6.34mm Pin				
25mm	SP16004	SP16005	SP16010	SP16011
50mm	SP16005	SP16010	SP16011	SP16012
75mm	SP16010	SP16011	SP16012	SP16013
100mm	SP16011	SP16012	SP16013	-
8.0mm Pin				
25mm	SP18050	SP18075	SP18100	SP18125
50mm	SP18075	SP18100	SP18125	SP18150
75mm	SP18100	SP18125	SP18150	SP18175
100mm	SP18125	SP18150	SP18175	SP18200
150mm	SP18150	SP18175	SP18200	-

TAPPING ACCESSORIES

TAPPING HEAD

- Protection against tap breakage ensured by an ultra sensitive and smooth multi-position operating ball-clutch
- Forward and reverse ball drive design transmits rotational power to the tap and disengages smoothly and silently
- Axial float ensures smooth tapping and better thread profile
- Cushioned drive incorporating compression and extension, eliminates the possibility of cross threading during the tapping process, and ensures clean and accurate threads
- A planetary gear reversing mechanism transmits smooth positive reverse to the tap retraction and it retracts 75% faster than it enters
- Accurate depth control by means of its precise neutral mechanism



Part No.	Description
SPTH102	3 - 12mm Tapping Head With #2 MT
SPTH103	8 - 20mm Tapping Head With #3 MT

QUICK CHANGE TAPPING CHUCK

- Use with QASB3 Tap Collets (pg 21)
- Tapping capacity M33



Part No.	Description
SPTH103-QC3	3MT Tapping Chuck, Quick Change, M14 - 33 Capacity
SPTH104-QCLK3	4MT Tapping Chuck, Quick Change, M14 - 33 Capacity With Compression Extension

QUICK CHANGE CHUCK MASTER HOLDER

- Quick change chuck master holder for use on vertical drilling and boring machines with right and left hand spindle rotation. Used with quick change adaptors for drilling (KD Adaptor) and for tapping (KTX Adaptor)
- Sliding the outer sleeve towards the spindle unlocks the adaptor and sliding away from the spindle locks it

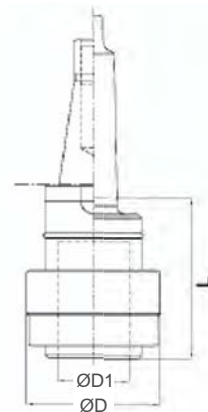

Part No.	Morse Taper	Suitable Adaptors	Shank Length	ØD	ØD1
SPTH105-TF5	#5 MT	Size 5	130.5mm	100	60

KD MORSE TAPER TOOLING ADAPTORS

- For use with any Morse Taper tooling, fits directly into Quick Change Chuck Master Holder
- Increases speed of changing from hole drilling tooling to tapping tooling



Part No.	Female MT	Suitable Chuck	ØD1	ØD3	Length (L)
SPTH105-KD5-2	#2 MT	SPTH105-TF5	60mm	73mm	25mm
SPTH105-KD5-3	#3 MT	SPTH105-TF5	60mm	73mm	25mm
SPTH105-KD5-4	#4 MT	SPTH105-TF5	60mm	73mm	31mm

KTX TAP ADAPTORS

- Fits directly into Quick Change Chuck Master Holder (pg 20)
- For use with QASB tap collets (see below)

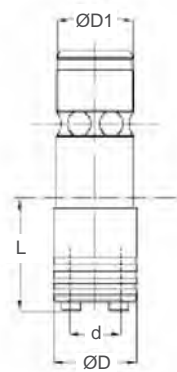

Part No.	Adaptor Size	Tapping Range	ØD1	ØD	d	Length (L)
SPTH103-KTX3/2	QASB2	M8 - M20	34mm	50mm	31mm	61mm
SPTH105-KTX5/2	QASB2	M8 - M20	60mm	50mm	31mm	61mm
SPTH105-KTX5/3	QASB3	M14 - M33	-	72mm	48mm	90mm
SPTH105-KTX5/4	QASB4	M22 - M52	-	95mm	60mm	110mm

QASB TAP COLLET

- Fits directly into KTX tap adaptors
- Safety clutch protects the tap from breakage

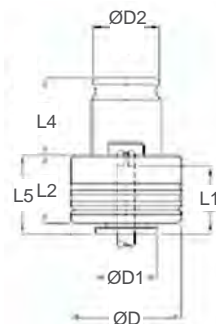

Part No.	Use Tap Adaptor	Suit Tap	ØD	ØD1	ØD2	L1	L3	L4	L5
SPTH105-QASB2-M8	QASB2	M8, 5/16" UNC/UNF/BSW, 1/8" BSP	50	30	31	30	31	35	34
SPTH105-QASB2-M10	QASB2	M10, 3/8" UNC/UNF/BSW, 1/4" BSP	50	30	31	30	31	35	34
SPTH105-QASB2-M12	QASB2	M12, 1/2" UNC/UNF/BSW	50	30	31	30	31	35	34
SPTH105-QASB2-M14	QASB2	M14, 9/16" UNC/UNF/BSW	50	30	31	30	31	35	34
SPTH105-QASB2-M16	QASB2	M16, 5/8" UNC/UNF/BSW, 3/4" BSP	50	30	31	30	31	35	34
SPTH105-QASB2-M20	QASB2	M18, M20, 3/4" UNC/UNF/BSW	50	30	31	30	31	35	34
SPTH105-QASB3-M14	QASB3	M14, 9/16" UNC/UNF/BSW	72	48	48	44	41	55.5	45
SPTH105-QASB3-M16	QASB3	M16, 5/8" UNC/UNF/BSW, 3/4" BSP	72	48	48	44	41	55.5	45
SPTH105-QASB3-M20	QASB3	M18, M20, 3/4" UNC/UNF/BSW	72	48	48	44	41	55.5	45
SPTH105-QASB3-M22	QASB3	M22, 7/8" UNC/UNF/BSW, 1/2" BSP	72	48	48	44	41	55.5	45
SPTH105-QASB3-M24	QASB3	M24, 1" UNC/UNF/BSW, 5/8" BSP	72	48	48	44	41	55.5	45
SPTH105-QASB3-M30	QASB3	M27, M30, 1-1/8" UNC/UNF/BSW, 3/4" BSP	72	48	48	44	41	55.5	45
SPTH105-QASB3-M33	QASB3	M33, 1-1/4" UNC/UNF/BSW, 7/8" BSP	72	48	48	44	41	55.5	45
SPTH105-QASB4-M22	QASB4	M22, 7/8" UNC/UNF/BSW, 1/2" BSP	95	60	60	71	61	63	68
SPTH105-QASB4-M24	QASB4	M24, 1" UNC/UNF/BSW, 5/8" BSP	95	60	60	71	61	63	68
SPTH105-QASB4-M27	QASB4	M27, M30, 1-1/8" UNC/UNF/BSW, 3/4" BSP	95	60	60	71	61	63	68
SPTH105-QASB4-M33	QASB4	M33, 1-1/4" UNC/UNF/BSW, 7/8" BSP	95	60	60	71	61	63	68
SPTH105-QASB4-M36	QASB4	M36, 1" BSP	95	60	60	71	61	63	68
SPTH105-QASB4-M39	QASB4	M39, M40, M42, 1-1/2" UNC/UNF/BSW	95	60	60	71	61	63	68
SPTH105-QASB4-M48	QASB4	M45, M48, 1-3/4" BSW, 1-1/4" BSP	95	60	60	71	61	63	68
SPTH105-QASB4-M52	QASB4	M52, 2" BSW, 1-1/2" BSP, 1-3/4" BSP	95	60	60	71	61	63	68



CUTTING FLUID

SOLUBLE METAL WORKING FLUID

Extra heavy duty, water soluble metal working fluid for use with Holemaker annular cutters and other arduous machining applications on ferrous and non ferrous metals.

- Formulated to extend tool life and improve surface finish
- Contains corrosion inhibitors to protect machine parts
- High resistance to bacterial and fungal growth

Mix 1 part fluid to 10 parts water



Part No.	Description
SPFLUID	500ml Metal Working Fluid
SPFLUID1	1 Litre Metal Working Fluid
SPFLUID5	5 Litre Metal Working Fluid
SPFLUID20	20 Litre Drum With Provision To Fit Tap

PRESSURE FEED COOLANT BOTTLE

The Pressure Feed Coolant Bottle connects directly to any magnetic drilling machine with a through spindle coolant system, making it possible to apply cutting fluid to the centre of the cut when drilling in vertical & horizontal positions. Also suitable for applications where a large amount of fluid is required - eg. large diameter, deep cutting, or very hard materials.



Part No.	Description
SA-WPB	1100ml Pressure Feed Coolant Bottle

FOR MACC SEMI SYNTHETIC METAL WORKING FLUID FOR RECIRCULATING SYSTEMS SEE PAGE 175



TAP MAGIC METAL WORKING FLUID EP-XTRA

Highly effective for all cutting operations on all metals. You will especially appreciate the performance of this cutting fluid on hard metals and with difficult extreme-pressure cuts of long duration. You will also note dramatic improvements in tool life.



Part No.	Description
TAP10004E	125ml Sprout Top Can (24 Per Carton)
TAP10125E	125ml Plastic Bottle
TAP10500E	500ml Plastic Bottle
TAP11000E	1 Litre Plastic Bottle
TAP15000E	5 Litre Plastic Bottle
TAP120000E	20 Litre Drum With Provision To Fit Tap

TAP MAGIC ALUMINIUM

Tap Magic Aluminium is a professional quality cutting fluid that is specially engineered for cutting and machining operations on aluminium and other non-ferrous metals. This is absolutely the most effective cutting fluid you can use for working with aluminium. Drilling, tapping, sawing - regardless of the cut, you'll enjoy superior performance, superb precision, and a beautiful microfine finish. Tap Magic Aluminium dissipates heat rapidly and provides closer tolerances. It also helps promote longer tool life.



Part No.	Description
TAP20004A	125ml Sprout Top Can (24 Per Carton)
TAP20016A-P	472ml Bottle (12 Per Carton)
TAP20640A	5 Gallon Drum

TAP MAGIC XTRA THICK

Tap Magic XTRA-THICK is without equal when making cuts of long duration on the hardest metals such as inconel, titanium, stainless and other hardened steels. In fact, it's highly effective on any metal up to 45 HRC! Tap Magic XTRA-THICK contains the proprietary EP-X3 additive for a performance boost. It virtually eliminates work hardening and it has an extended cling time – so it stays with the tool and work piece longer for deep hole cuts.



Part No.	Description
TAP70016E	472ml Bottle (12 Per Carton)



CUTTING TOOLS

Annular Cutters - H.S.S.	25	Step Drills	62
Annular Cutters - T.C.T.	26	Countersinks	63
Weldon Shank Cutting Tools	45	Carbide Burrs	64
Combination Drill Tap	46	Hand Deburring Tools	69
Sheet Metal Cutters	47	Adjustable Hand Reamers	70
Drill Bits	48	Tap Wrenches	71
Bi - Metal Holesaws	52	Button Die Holders	71
T.C.T. Holesaws	56		

Over 750 different types and sizes of annular cutters stocked!

Our diverse range of styles, and wide range of sizes, means that even the most demanding jobs can be completed successfully!

- Difficult materials such as Bisalloy, wear plate, stainless steel & exotic alloys
- Large diameters & depths
- General engineering
- Railway line & more!

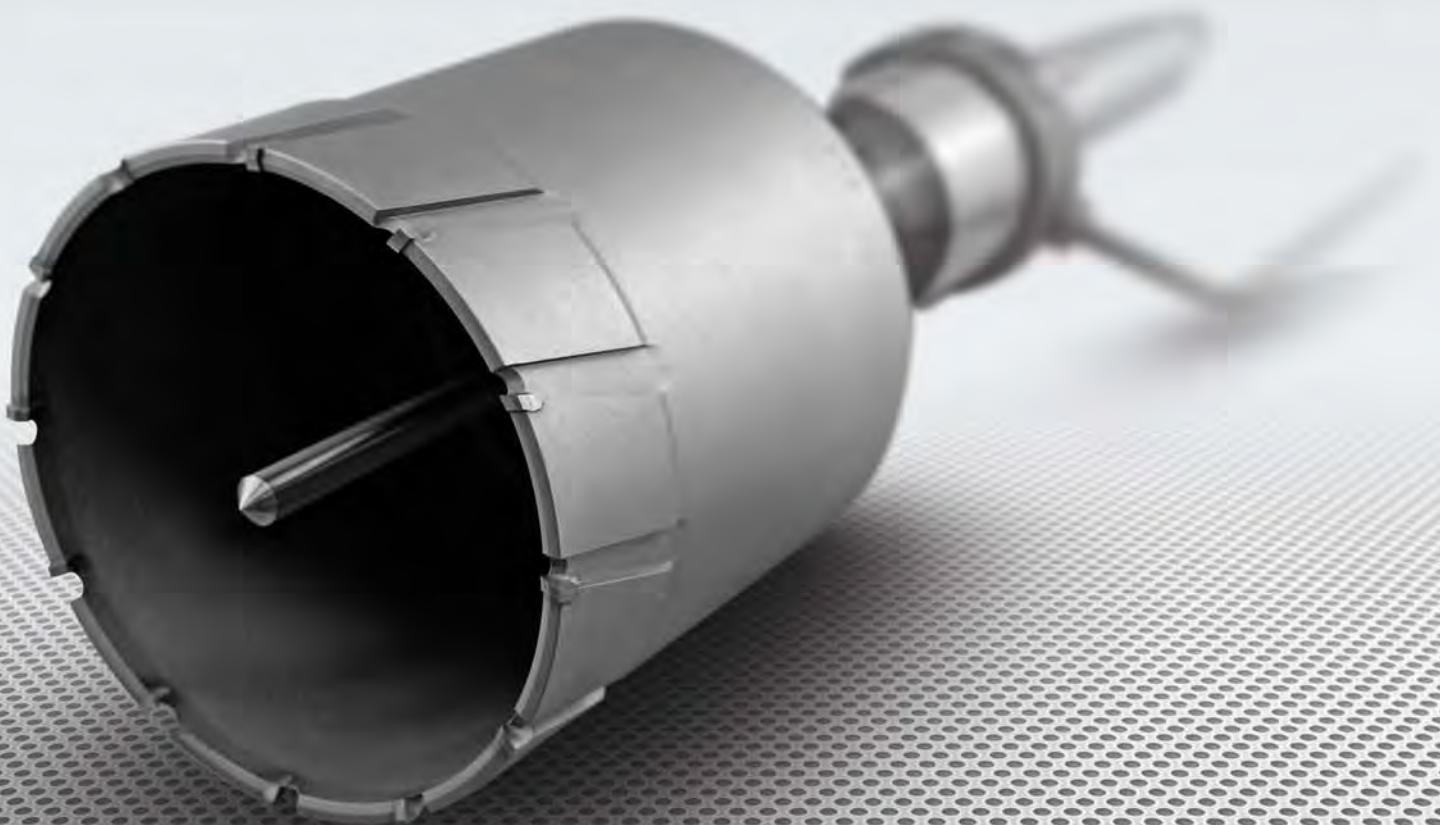

CUTTER SELECTION GUIDE

Cutter Type	Features	Diameter Available	Cut Depth Available	Applications	Pg #
Silver Series Metric 	<ul style="list-style-type: none"> • M2AL High Speed Steel • Universal Shank • Multi-Cut Geometry • Step Hardened 	• 12 to 60mm Metric	• 25mm & 50mm	• General Purpose	26, 27
Silver Series Imperial 	<ul style="list-style-type: none"> • M2AL High Speed Steel • Multi-Cut Geometry • Step Hardened 	• 7/16" to 2-1/4" Imperial	• 1" & 2"	• General Purpose	28
Gold Series Metric 	<ul style="list-style-type: none"> • M2AL High Speed Steel • Titanium Nitride Coated • Universal Shank • Multi-Cut Geometry • Step Hardened 	• 12 to 60mm Metric	• 25mm, 50mm & 75mm	• General Purpose	30, 31
Super-Cut 	<ul style="list-style-type: none"> • Made In U.S.A • Highest Quality • M2 High Speed Steel • Multi-Cut Geometry 	<ul style="list-style-type: none"> • 12 to 60mm Metric • 7/16" to 2-1/2" Imperial 	<ul style="list-style-type: none"> • 25mm, 50mm & 75mm • 1", 2" & 3" 	• General Purpose	34, 35, 36
Super-Cut TICN 	<ul style="list-style-type: none"> • Titanium Carbon Nitride Coated • Made In U.S.A • M2 High Speed Steel • Multi-Cut Geometry 	• 12 to 32mm Metric	• 25mm & 50mm	<ul style="list-style-type: none"> • Stainless Steel • Cast Iron 	38
Super-Cut M42 Cobalt 	<ul style="list-style-type: none"> • M42 High Speed Steel • 8% Cobalt • Titanium Nitride Coated • Made In U.S.A • Multi-Cut Geometry 	• 1/2" to 1" Imperial	• 1"	<ul style="list-style-type: none"> • Truck Chassis • Hardened Steels 	38
Super-Cut M42 Chassis 	<ul style="list-style-type: none"> • Stack Ground Geometry • M42 High Speed Steel • 8% Cobalt • Titanium Nitride Coated • Made In U.S.A 	• 1/2" to 1" Imperial	• 1"	<ul style="list-style-type: none"> • Truck Chassis • Multi-Layered Steel 	38
Pro-Cut 	<ul style="list-style-type: none"> • ASP Powder Steel • Multi-Cut Geometry • Incredible Performance 	• 12 to 22mm Metric	• 25mm & 50mm	<ul style="list-style-type: none"> • Rail Line • Hard Materials • Stainless Steel • Wear Plate 	39
Maxi-Cut 	<ul style="list-style-type: none"> • Tungsten Carbide Tipped • Increased Resistance to Breakage • Multi-Cut Geometry 	<ul style="list-style-type: none"> • 12 to 150mm Metric • 5/8" to 2-3/8" Imperial 	<ul style="list-style-type: none"> • 35mm, 50mm, 75mm • 100mm & 150mm 	<ul style="list-style-type: none"> • Large Diameters • Stainless Steel • Hard Materials • Wear Plate 	40, 41, 42, 43, 44
Maxi-Rail 	<ul style="list-style-type: none"> • Tungsten Carbide Tipped • Increased Resistance to Breakage • Multi-Cut Geometry 	• 18 to 35mm Metric	• 25mm	<ul style="list-style-type: none"> • Rail Line • Hard Materials • Wear Plate 	45

Note: see product pages for exact sizes available

SILVER SERIES METRIC CUTTERS

METRIC SILVER 25MM DEPTH OF CUT



M2AL HIGH SPEED STEEL MATERIAL

M2AL high speed steel is a high alloy material with a hardness of up to 67.5 HRC, designed for increased endurance of the cutting edge and tool life.

STEP HARDENED PROCESS

This state of the art manufacturing process produces cutters with extremely hard tooth tips for increased cutter performance, while maintaining a softer body which is less susceptible to breakage than standard high speed steel cutters.

MULTI-CUT GEOMETRY

Provides smooth and fast cutting, with decreased chatter. This also increases the cutters ability to remove swarf away from the cut, and helps to enhance centring.

FULLY GROUND WITH INTERNAL RELIEF

This feature allows Holemaker cutters to produce reamed quality, burr-free holes, and also helps to reduce torque and horsepower requirements.

UNIVERSAL SHANK

19.05mm (3/4") universal shank for cutters up to and including 60mm diameter. Featuring 2 flat sections to suit most magnetic base drilling machines.

Cutters of diameters 61mm and above feature a 31.75mm, 1-1/4" Weldon shank.



Part No.	Diameter	Depth Of Cut	Pilot Pin Diameter	Shank Diameter
AS1225	12mm	25mm	6.34mm	3/4" (19.05mm)
AS1325	13mm	25mm	6.34mm	3/4" (19.05mm)
AS1425	14mm	25mm	6.34mm	3/4" (19.05mm)
AS1525	15mm	25mm	6.34mm	3/4" (19.05mm)
AS1625	16mm	25mm	6.34mm	3/4" (19.05mm)
AS1725	17mm	25mm	6.34mm	3/4" (19.05mm)
AS1825	18mm	25mm	6.34mm	3/4" (19.05mm)
AS1925	19mm	25mm	6.34mm	3/4" (19.05mm)
AS2025	20mm	25mm	6.34mm	3/4" (19.05mm)
AS2125	21mm	25mm	6.34mm	3/4" (19.05mm)
AS2225	22mm	25mm	6.34mm	3/4" (19.05mm)
AS2325	23mm	25mm	6.34mm	3/4" (19.05mm)
AS2425	24mm	25mm	6.34mm	3/4" (19.05mm)
AS2525	25mm	25mm	6.34mm	3/4" (19.05mm)
AS2625	26mm	25mm	6.34mm	3/4" (19.05mm)
AS2725	27mm	25mm	6.34mm	3/4" (19.05mm)
AS2825	28mm	25mm	6.34mm	3/4" (19.05mm)
AS2925	29mm	25mm	6.34mm	3/4" (19.05mm)
AS3025	30mm	25mm	6.34mm	3/4" (19.05mm)
AS3125	31mm	25mm	6.34mm	3/4" (19.05mm)
AS3225	32mm	25mm	6.34mm	3/4" (19.05mm)
AS3325	33mm	25mm	6.34mm	3/4" (19.05mm)
AS3425	34mm	25mm	6.34mm	3/4" (19.05mm)
AS3525	35mm	25mm	6.34mm	3/4" (19.05mm)
AS3625	36mm	25mm	6.34mm	3/4" (19.05mm)
AS3725	37mm	25mm	6.34mm	3/4" (19.05mm)
AS3825	38mm	25mm	6.34mm	3/4" (19.05mm)
AS3925	39mm	25mm	6.34mm	3/4" (19.05mm)
AS4025	40mm	25mm	6.34mm	3/4" (19.05mm)
AS4125	41mm	25mm	6.34mm	3/4" (19.05mm)
AS4225	42mm	25mm	6.34mm	3/4" (19.05mm)
AS4325	43mm	25mm	6.34mm	3/4" (19.05mm)
AS4425	44mm	25mm	6.34mm	3/4" (19.05mm)
AS4525	45mm	25mm	6.34mm	3/4" (19.05mm)
AS4625	46mm	25mm	6.34mm	3/4" (19.05mm)
AS4725	47mm	25mm	6.34mm	3/4" (19.05mm)
AS4825	48mm	25mm	6.34mm	3/4" (19.05mm)
AS4925	49mm	25mm	6.34mm	3/4" (19.05mm)
AS5025	50mm	25mm	6.34mm	3/4" (19.05mm)
AS5125	51mm	25mm	6.34mm	3/4" (19.05mm)
AS5225	52mm	25mm	6.34mm	3/4" (19.05mm)

6.34mm Pilot Pin to suit - Part# SP16003

METRIC SILVER 50MM DEPTH OF CUT



Part No.	Diameter	Depth Of Cut	Pilot Pin Diameter	Shank Diameter
AS1250	12mm	50mm	6.34mm	3/4" (19.05mm)
AS1350	13mm	50mm	6.34mm	3/4" (19.05mm)
AS1450	14mm	50mm	6.34mm	3/4" (19.05mm)
AS1550	15mm	50mm	6.34mm	3/4" (19.05mm)
AS1650	16mm	50mm	6.34mm	3/4" (19.05mm)
AS1750	17mm	50mm	6.34mm	3/4" (19.05mm)
AS1850	18mm	50mm	6.34mm	3/4" (19.05mm)
AS1950	19mm	50mm	6.34mm	3/4" (19.05mm)
AS2050	20mm	50mm	6.34mm	3/4" (19.05mm)
AS2150	21mm	50mm	6.34mm	3/4" (19.05mm)
AS2250	22mm	50mm	6.34mm	3/4" (19.05mm)
AS2350	23mm	50mm	6.34mm	3/4" (19.05mm)
AS2450	24mm	50mm	6.34mm	3/4" (19.05mm)
AS2550	25mm	50mm	6.34mm	3/4" (19.05mm)
AS2650	26mm	50mm	6.34mm	3/4" (19.05mm)
AS2750	27mm	50mm	6.34mm	3/4" (19.05mm)
AS2850	28mm	50mm	6.34mm	3/4" (19.05mm)
AS2950	29mm	50mm	6.34mm	3/4" (19.05mm)
AS3050	30mm	50mm	6.34mm	3/4" (19.05mm)
AS3150	31mm	50mm	6.34mm	3/4" (19.05mm)
AS3250	32mm	50mm	6.34mm	3/4" (19.05mm)
AS3350	33mm	50mm	6.34mm	3/4" (19.05mm)
AS3450	34mm	50mm	6.34mm	3/4" (19.05mm)
AS3550	35mm	50mm	6.34mm	3/4" (19.05mm)
AS3650	36mm	50mm	6.34mm	3/4" (19.05mm)
AS3750	37mm	50mm	6.34mm	3/4" (19.05mm)
AS3850	38mm	50mm	6.34mm	3/4" (19.05mm)
AS3950	39mm	50mm	6.34mm	3/4" (19.05mm)
AS4050	40mm	50mm	6.34mm	3/4" (19.05mm)
AS4150	41mm	50mm	6.34mm	3/4" (19.05mm)
AS4250	42mm	50mm	6.34mm	3/4" (19.05mm)
AS4350	43mm	50mm	6.34mm	3/4" (19.05mm)
AS4450	44mm	50mm	6.34mm	3/4" (19.05mm)
AS4550	45mm	50mm	6.34mm	3/4" (19.05mm)
AS4650	46mm	50mm	6.34mm	3/4" (19.05mm)
AS4750	47mm	50mm	6.34mm	3/4" (19.05mm)
AS4850	48mm	50mm	6.34mm	3/4" (19.05mm)
AS4950	49mm	50mm	6.34mm	3/4" (19.05mm)
AS5050	50mm	50mm	6.34mm	3/4" (19.05mm)
AS5150	51mm	50mm	6.34mm	3/4" (19.05mm)
AS5250	52mm	50mm	6.34mm	3/4" (19.05mm)
AS5550	55mm	50mm	6.34mm	3/4" (19.05mm)
AS5950	59mm	50mm	6.34mm	3/4" (19.05mm)
AS6050	60mm	50mm	6.34mm	3/4" (19.05mm)

6.34mm Pilot Pin to suit - Part# SP16004

Part No.	Diameter	Depth Of Cut	Pilot Pin Diameter	Shank Diameter
AS6150	61mm	50mm	6.34mm	1-1/4" (31.75mm)
AS6250	62mm	50mm	6.34mm	1-1/4" (31.75mm)
AS6350	63mm	50mm	6.34mm	1-1/4" (31.75mm)
AS6450	64mm	50mm	6.34mm	1-1/4" (31.75mm)
AS6550	65mm	50mm	6.34mm	1-1/4" (31.75mm)

6.34mm Pilot Pin to suit - Part# SP16008

SILVER SERIES IMPERIAL CUTTERS

- M2AL high speed steel material
- Step hardened process
- Multi-cut geometry
- Fully ground with internal relief

IMPERIAL SILVER 1" DEPTH OF CUT

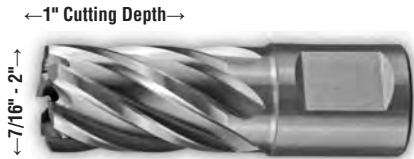

Part No.	Diameter	Depth Of Cut	Pilot Pin Diameter	Shank Diameter
HM7/16X1	7/16"	11.11mm	1"	4.70mm
HM1/2X1	1/2"	12.70mm	1"	6.34mm
HM9/16X1	9/16"	14.28mm	1"	6.34mm
HM5/8X1	5/8"	15.87mm	1"	6.34mm
HM11/16X1	11/16"	17.46mm	1"	6.34mm
HM3/4X1	3/4"	19.05mm	1"	6.34mm
HM13/16X1	13/16"	20.64mm	1"	6.34mm
HM7/8X1	7/8"	22.22mm	1"	6.34mm
HM15/16X1	15/16"	23.81mm	1"	6.34mm
HM1X1	1"	25.40mm	1"	6.34mm
HM1-1/8X1	1-1/8"	28.57mm	1"	6.34mm
HM1-3/16X1	1-3/16"	30.16mm	1"	6.34mm
HM1-1/4X1	1-1/4"	31.75mm	1"	6.34mm
HM1-5/16X1	1-5/16"	33.34mm	1"	6.34mm
HM1-3/8X1	1-3/8"	34.92mm	1"	6.34mm
HM1-1/2X1	1-1/2"	38.10mm	1"	6.34mm
HM1-5/8X1	1-5/8"	41.27mm	1"	6.34mm
HM1-3/4X1	1-3/4"	44.45mm	1"	6.34mm
HM1-7/8X1	1-7/8"	47.62mm	1"	6.34mm
HM2X1	2"	50.80mm	1"	6.34mm

4.70mm Pilot Pin to suit - Part# SP16001
6.34mm Pilot Pin to suit - Part# SP16003

IMPERIAL SILVER 2" DEPTH OF CUT



Part No.	Diameter	Depth Of Cut	Pilot Pin Diameter	Shank Diameter
HM27/64X2	27/64"	10.71mm	2"	4.70mm
HM7/16X2	7/16"	11.11mm	2"	4.70mm
HM1/2X2	1/2"	12.70mm	2"	6.34mm
HM9/16X2	9/16"	14.28mm	2"	6.34mm
HM5/8X2	5/8"	15.87mm	2"	6.34mm
HM11/16X2	11/16"	17.46mm	2"	6.34mm
HM3/4X2	3/4"	19.05mm	2"	6.34mm
HM13/16X2	13/16"	20.64mm	2"	6.34mm
HM7/8X2	7/8"	22.22mm	2"	6.34mm
HM15/16X2	15/16"	23.81mm	2"	6.34mm
HM1X2	1"	25.40mm	2"	6.34mm
HM1-1/8X2	1-1/8"	28.57mm	2"	6.34mm
HM1-3/16X2	1-3/16"	30.16mm	2"	6.34mm
HM1-1/4X2	1-1/4"	31.75mm	2"	6.34mm
HM1-5/16X2	1-5/16"	33.34mm	2"	6.34mm
HM1-3/8X2	1-3/8"	34.92mm	2"	6.34mm
HM1-1/2X2	1-1/2"	38.10mm	2"	6.34mm
HM1-5/8X2	1-5/8"	41.27mm	2"	6.34mm
HM1-3/4X2	1-3/4"	44.45mm	2"	6.34mm
HM1-7/8X2	1-7/8"	47.62mm	2"	6.34mm
HM2X2	2"	50.80mm	2"	6.34mm
HM2-1/16X2	2-1/16"	52.39mm	2"	6.34mm
HM2-1/8X2	2-1/8"	53.97mm	2"	6.34mm
HM2-1/4X2	2-1/4"	57.15mm	2"	6.34mm

4.70mm Pilot Pin to suit - Part# SP16002
6.34mm Pilot Pin to suit - Part# SP16004

SILVER SERIES CUTTER SETS



PART NO. ASSET-A | SHORT SERIES METRIC SET - 5 CUTTERS

Quantity	Part No.	Diameter	Depth Of Cut
1	AS1425	14mm	25mm
1	AS1625	16mm	25mm
1	AS1825	18mm	25mm
1	AS2025	20mm	25mm
1	AS2225	22mm	25mm

PART NO. ASSET-B | SHORT SERIES METRIC SET - 10 CUTTERS

1	AS1225	12mm	25mm
1	AS1325	13mm	25mm
1	AS1425	14mm	25mm
1	AS1625	16mm	25mm
1	AS1725	17mm	25mm
1	AS1825	18mm	25mm
1	AS2025	20mm	25mm
1	AS2225	22mm	25mm
1	AS2425	24mm	25mm
1	AS2625	26mm	25mm

PART NO. ASSET-C | LONG SERIES METRIC SET - 5 CUTTERS

1	AS1450	14mm	50mm
1	AS1650	16mm	50mm
1	AS1850	18mm	50mm
1	AS2050	20mm	50mm
1	AS2250	22mm	50mm

All Sets Include Pilot Pins

PART NO. ASSET-D | COMBINATION METRIC SET - 10 CUTTERS

Quantity	Part No.	Diameter	Depth Of Cut
1	AS1425	14mm	25mm
1	AS1625	16mm	25mm
1	AS1825	18mm	25mm
1	AS2025	20mm	25mm
1	AS2225	22mm	25mm
1	AS1450	14mm	50mm
1	AS1650	16mm	50mm
1	AS1850	18mm	50mm
1	AS2050	20mm	50mm
1	AS2250	22mm	50mm

PART NO. HMSET-E | SHORT SERIES IMPERIAL SET - 5 CUTTERS

1	HM1/2X1	1/2"	1"
1	HM5/8X1	5/8"	1"
1	HM3/4X1	3/4"	1"
1	HM7/8X1	7/8"	1"
1	HM1X1	1"	1"

PART NO. HMSET-F | COMBINATION IMPERIAL SET - 10 CUTTERS

1	HM1/2X1	1/2"	1"
1	HM5/8X1	5/8"	1"
1	HM3/4X1	3/4"	1"
1	HM7/8X1	7/8"	1"
1	HM1X1	1"	1"
1	HM1/2X2	1/2"	2"
1	HM5/8X2	5/8"	2"
1	HM3/4X2	3/4"	2"
1	HM7/8X2	7/8"	2"
1	HM1X2	1"	2"

PART NO. ASSET-G | SHORT SERIES METRIC SET - 6 CUTTERS

1	AS1325	13mm	25mm
1	AS1425	14mm	25mm
1	AS1625	16mm	25mm
1	AS1825	18mm	25mm
1	AS2225	22mm	25mm
1	AS2625	26mm	25mm

PART NO. ASSET-K | LONG SERIES METRIC SET - 6 CUTTERS

1	AS1350	13mm	50mm
1	AS1450	14mm	50mm
1	AS1650	16mm	50mm
1	AS1850	18mm	50mm
1	AS2250	22mm	50mm
1	AS2650	26mm	50mm

PART NO. ASSET-Z | SHORT SERIES METRIC SET - 3 CUTTERS

1	AS1425	14mm	25mm
1	AS1825	18mm	25mm
1	AS2225	22mm	25mm



GOLD SERIES METRIC CUTTERS

TITANIUM NITRIDE COATING

The titanium nitride coating significantly increases the tool life by providing the following benefits:

- Increased surface hardness to 85HRC
- Ceramic surface, reducing friction by up to 30%
- Especially resistant to cold welding
- Suitable for cutting a wide range of materials

M2AL HIGH SPEED STEEL MATERIAL

M2AL high speed steel is a high alloy material with a hardness of up to 67.5 HRC, designed for increased endurance of the cutting edge and tool life.

STEP HARDENED PROCESS

This state of the art manufacturing process produces cutters with extremely hard tooth tips for increased cutter performance, while maintaining a softer body which is less susceptible to breakage than standard high speed steel cutters.

MULTI-CUT GEOMETRY

Provides smooth and fast cutting, with decreased chatter. This also increases the cutters ability to remove swarf away from the cut, and helps to enhance centring.

FULLY GROUND WITH INTERNAL RELIEF

This feature allows Holemaker cutters to produce reamed quality, burr-free holes, and also helps to reduce torque and horsepower requirements.

UNIVERSAL SHANK

19.05mm (3/4") universal shank with 2 flat sections to suit most magnetic base drilling machines.

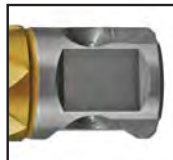

METRIC GOLD 25MM DEPTH OF CUT

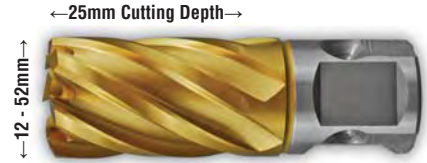

Part No.	Diameter	Depth Of Cut	Pilot Pin Diameter	Shank Diameter
AT1425A	14mm	25mm	4.70mm	3/4" (19.05mm)
AT1225	12mm	25mm	6.34mm	3/4" (19.05mm)
AT1325	13mm	25mm	6.34mm	3/4" (19.05mm)
AT1425	14mm	25mm	6.34mm	3/4" (19.05mm)
AT1525	15mm	25mm	6.34mm	3/4" (19.05mm)
AT1625	16mm	25mm	6.34mm	3/4" (19.05mm)
AT16.525	16.5mm	25mm	6.34mm	3/4" (19.05mm)
AT1725	17mm	25mm	6.34mm	3/4" (19.05mm)
AT1825	18mm	25mm	6.34mm	3/4" (19.05mm)
AT1925	19mm	25mm	6.34mm	3/4" (19.05mm)
AT2025	20mm	25mm	6.34mm	3/4" (19.05mm)
AT2125	21mm	25mm	6.34mm	3/4" (19.05mm)
AT2225	22mm	25mm	6.34mm	3/4" (19.05mm)
AT2325	23mm	25mm	6.34mm	3/4" (19.05mm)
AT2425	24mm	25mm	6.34mm	3/4" (19.05mm)
AT2525	25mm	25mm	6.34mm	3/4" (19.05mm)
AT2625	26mm	25mm	6.34mm	3/4" (19.05mm)
AT2725	27mm	25mm	6.34mm	3/4" (19.05mm)
AT2825	28mm	25mm	6.34mm	3/4" (19.05mm)
AT2925	29mm	25mm	6.34mm	3/4" (19.05mm)
AT3025	30mm	25mm	6.34mm	3/4" (19.05mm)
AT3125	31mm	25mm	6.34mm	3/4" (19.05mm)
AT3225	32mm	25mm	6.34mm	3/4" (19.05mm)
AT3325	33mm	25mm	6.34mm	3/4" (19.05mm)
AT3425	34mm	25mm	6.34mm	3/4" (19.05mm)
AT3525	35mm	25mm	6.34mm	3/4" (19.05mm)
AT3625	36mm	25mm	6.34mm	3/4" (19.05mm)
AT3725	37mm	25mm	6.34mm	3/4" (19.05mm)
AT3825	38mm	25mm	6.34mm	3/4" (19.05mm)
AT3925	39mm	25mm	6.34mm	3/4" (19.05mm)
AT4025	40mm	25mm	6.34mm	3/4" (19.05mm)
AT4125	41mm	25mm	6.34mm	3/4" (19.05mm)
AT4225	42mm	25mm	6.34mm	3/4" (19.05mm)
AT4325	43mm	25mm	6.34mm	3/4" (19.05mm)
AT4425	44mm	25mm	6.34mm	3/4" (19.05mm)
AT4525	45mm	25mm	6.34mm	3/4" (19.05mm)
AT4625	46mm	25mm	6.34mm	3/4" (19.05mm)
AT4725	47mm	25mm	6.34mm	3/4" (19.05mm)
AT4825	48mm	25mm	6.34mm	3/4" (19.05mm)
AT4925	49mm	25mm	6.34mm	3/4" (19.05mm)
AT5025	50mm	25mm	6.34mm	3/4" (19.05mm)
AT5125	51mm	25mm	6.34mm	3/4" (19.05mm)
AT5225	52mm	25mm	6.34mm	3/4" (19.05mm)

4.70mm Pilot Pin to suit - Part# SP16001

6.34mm Pilot Pin to suit - Part# SP16003

METRIC GOLD 50MM DEPTH OF CUT



METRIC GOLD 75MM DEPTH OF CUT



Part No.	Diameter	Depth Of Cut	Pilot Pin Diameter	Shank Diameter
AT1250	12mm	50mm	6.34mm	3/4" (19.05mm)
AT1350	13mm	50mm	6.34mm	3/4" (19.05mm)
AT1450	14mm	50mm	6.34mm	3/4" (19.05mm)
AT1550	15mm	50mm	6.34mm	3/4" (19.05mm)
AT1650	16mm	50mm	6.34mm	3/4" (19.05mm)
AT16.550	16.5mm	50mm	6.34mm	3/4" (19.05mm)
AT1750	17mm	50mm	6.34mm	3/4" (19.05mm)
AT1850	18mm	50mm	6.34mm	3/4" (19.05mm)
AT1950	19mm	50mm	6.34mm	3/4" (19.05mm)
AT2050	20mm	50mm	6.34mm	3/4" (19.05mm)
AT2150	21mm	50mm	6.34mm	3/4" (19.05mm)
AT2250	22mm	50mm	6.34mm	3/4" (19.05mm)
AT2350	23mm	50mm	6.34mm	3/4" (19.05mm)
AT2450	24mm	50mm	6.34mm	3/4" (19.05mm)
AT2550	25mm	50mm	6.34mm	3/4" (19.05mm)
AT2650	26mm	50mm	6.34mm	3/4" (19.05mm)
AT2750	27mm	50mm	6.34mm	3/4" (19.05mm)
AT2850	28mm	50mm	6.34mm	3/4" (19.05mm)
AT2950	29mm	50mm	6.34mm	3/4" (19.05mm)
AT3050	30mm	50mm	6.34mm	3/4" (19.05mm)
AT3150	31mm	50mm	6.34mm	3/4" (19.05mm)
AT3250	32mm	50mm	6.34mm	3/4" (19.05mm)
AT3350	33mm	50mm	6.34mm	3/4" (19.05mm)
AT3450	34mm	50mm	6.34mm	3/4" (19.05mm)
AT3550	35mm	50mm	6.34mm	3/4" (19.05mm)
AT3650	36mm	50mm	6.34mm	3/4" (19.05mm)
AT3750	37mm	50mm	6.34mm	3/4" (19.05mm)
AT3850	38mm	50mm	6.34mm	3/4" (19.05mm)
AT3950	39mm	50mm	6.34mm	3/4" (19.05mm)
AT4050	40mm	50mm	6.34mm	3/4" (19.05mm)
AT4150	41mm	50mm	6.34mm	3/4" (19.05mm)
AT4250	42mm	50mm	6.34mm	3/4" (19.05mm)
AT4350	43mm	50mm	6.34mm	3/4" (19.05mm)
AT4450	44mm	50mm	6.34mm	3/4" (19.05mm)
AT4550	45mm	50mm	6.34mm	3/4" (19.05mm)
AT4650	46mm	50mm	6.34mm	3/4" (19.05mm)
AT4750	47mm	50mm	6.34mm	3/4" (19.05mm)
AT4850	48mm	50mm	6.34mm	3/4" (19.05mm)
AT4950	49mm	50mm	6.34mm	3/4" (19.05mm)
AT5050	50mm	50mm	6.34mm	3/4" (19.05mm)
AT5150	51mm	50mm	6.34mm	3/4" (19.05mm)
AT5250	52mm	50mm	6.34mm	3/4" (19.05mm)
AT5550	55mm	50mm	6.34mm	3/4" (19.05mm)
AT5950	59mm	50mm	6.34mm	3/4" (19.05mm)
AT6050	60mm	50mm	6.34mm	3/4" (19.05mm)

6.34mm Pilot Pin to suit - Part# SP16004

Part No.	Diameter	Depth Of Cut	Pilot Pin Diameter	Shank Diameter
AT1875	18mm	75mm	8mm	3/4" (19.05mm)
AT1975	19mm	75mm	8mm	3/4" (19.05mm)
AT2075	20mm	75mm	8mm	3/4" (19.05mm)
AT2175	21mm	75mm	8mm	3/4" (19.05mm)
AT2275	22mm	75mm	8mm	3/4" (19.05mm)
AT2375	23mm	75mm	8mm	3/4" (19.05mm)
AT2475	24mm	75mm	8mm	3/4" (19.05mm)
AT2575	25mm	75mm	8mm	3/4" (19.05mm)
AT2675	26mm	75mm	8mm	3/4" (19.05mm)
AT2775	27mm	75mm	8mm	3/4" (19.05mm)
AT2875	28mm	75mm	8mm	3/4" (19.05mm)
AT2975	29mm	75mm	8mm	3/4" (19.05mm)
AT3075	30mm	75mm	8mm	3/4" (19.05mm)
AT3175	31mm	75mm	8mm	3/4" (19.05mm)
AT3275	32mm	75mm	8mm	3/4" (19.05mm)

8mm Pilot Pin to suit - Part# SP18075

GOLD SERIES CUTTER SETS



PART NO. ATSET-A | SHORT SERIES METRIC SET - 5 CUTTERS

Quantity	Part No.	Diameter	Depth Of Cut
1	AT1425	14mm	25mm
1	AT1625	16mm	25mm
1	AT1825	18mm	25mm
1	AT2025	20mm	25mm
1	AT2225	22mm	25mm

PART NO. ATSET-B | SHORT SERIES METRIC SET - 10 CUTTERS

1	AT1225	12mm	25mm
1	AT1325	13mm	25mm
1	AT1425	14mm	25mm
1	AT1625	16mm	25mm
1	AT1725	17mm	25mm
1	AT1825	18mm	25mm
1	AT2025	20mm	25mm
1	AT2225	22mm	25mm
1	AT2425	24mm	25mm
1	AT2625	26mm	25mm

PART NO. ATSET-C | LONG SERIES METRIC SET - 5 CUTTERS

1	AT1450	14mm	50mm
1	AT1650	16mm	50mm
1	AT1850	18mm	50mm
1	AT2050	20mm	50mm
1	AT2250	22mm	50mm

All Sets Include Pilot Pins

PART NO. ATSET-D | COMBINATION METRIC SET - 10 CUTTERS

Quantity	Part No.	Diameter	Depth Of Cut
1	AT1425	14mm	25mm
1	AT1625	16mm	25mm
1	AT1825	18mm	25mm
1	AT2025	20mm	25mm
1	AT2225	22mm	25mm
1	AT1450	14mm	50mm
1	AT1650	16mm	50mm
1	AT1850	18mm	50mm
1	AT2050	20mm	50mm
1	AT2250	22mm	50mm

PART NO. ATSET-G | SHORT SERIES METRIC SET - 6 CUTTERS

1	AT1325	13mm	25mm
1	AT1425	14mm	25mm
1	AT1625	16mm	25mm
1	AT1825	18mm	25mm
1	AT2225	22mm	25mm
1	AT2625	26mm	25mm

PART NO. ATSET-K | LONG SERIES METRIC SET - 6 CUTTERS

1	AT1350	13mm	50mm
1	AT1450	14mm	50mm
1	AT1650	16mm	50mm
1	AT1850	18mm	50mm
1	AT2250	22mm	50mm
1	AT2650	26mm	50mm

EXTENSIVE RANGE OF IN STORE MERCHANDISING PACKAGES AVAILABLE

Large range of sizes and styles including:

- Small counter top displays
- Hang pack displays
- Clamp stands
- 1.5m to 2.4m high product display stands



PLEASE CONTACT ITM
FOR A COPY OF OUR
MERCHANDISING
CATALOGUE



SUPER-CUT METRIC CUTTERS



MADE IN THE U.S.A

Holemaker Super-Cut cutters are made by the No.1 manufacturer in the U.S.A using the highest quality materials and produced on ultra modern CNC machinery to exacting standards.

M2 HIGH SPEED STEEL MATERIAL

M2 high speed steel material, providing a very high wear resistance, designed for increased endurance of the cutting edge and tool life.

MULTI-CUT GEOMETRY

Holemaker Super-Cut cutters have a unique state-of-the-art geometry, which includes alternating tooth angles across the entire range.

The alternating tooth angles equalise forces to provide smooth cutting and keeps the cutter path straight and even through the deepest holes.

FULLY GROUND WITH INTERNAL RELIEF

This feature allows Holemaker Super-Cut cutters to produce reamed quality, burr-free holes, and also helps to reduce torque and horsepower requirements.

METRIC SUPER-CUT 25MM DEPTH OF CUT

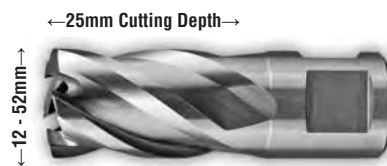

Part No.	Diameter	Depth Of Cut	Pilot Pin Diameter	Shank Diameter
SC1225	12mm	25mm	4.70mm	3/4" (19.05mm)
SC1325	13mm	25mm	4.70mm	3/4" (19.05mm)
SC1425	14mm	25mm	4.70mm	3/4" (19.05mm)
SC1525	15mm	25mm	6.34mm	3/4" (19.05mm)
SC1625	16mm	25mm	6.34mm	3/4" (19.05mm)
SC16.525	16.5mm	25mm	6.34mm	3/4" (19.05mm)
SC1725	17mm	25mm	6.34mm	3/4" (19.05mm)
SC1825	18mm	25mm	6.34mm	3/4" (19.05mm)
SC1925	19mm	25mm	6.34mm	3/4" (19.05mm)
SC2025	20mm	25mm	6.34mm	3/4" (19.05mm)
SC2225	22mm	25mm	6.34mm	3/4" (19.05mm)
SC2325	23mm	25mm	6.34mm	3/4" (19.05mm)
SC2425	24mm	25mm	6.34mm	3/4" (19.05mm)
SC2525	25mm	25mm	6.34mm	3/4" (19.05mm)
SC2625	26mm	25mm	6.34mm	3/4" (19.05mm)
SC2725	27mm	25mm	6.34mm	3/4" (19.05mm)
SC2825	28mm	25mm	6.34mm	3/4" (19.05mm)
SC2925	29mm	25mm	6.34mm	3/4" (19.05mm)
SC3025	30mm	25mm	6.34mm	3/4" (19.05mm)
SC3125	31mm	25mm	6.34mm	3/4" (19.05mm)
SC3225	32mm	25mm	6.34mm	3/4" (19.05mm)
SC3325	33mm	25mm	6.34mm	3/4" (19.05mm)
SC3425	34mm	25mm	6.34mm	3/4" (19.05mm)
SC3525	35mm	25mm	6.34mm	3/4" (19.05mm)
SC3625	36mm	25mm	6.34mm	3/4" (19.05mm)
SC3825	38mm	25mm	6.34mm	3/4" (19.05mm)
SC4025	40mm	25mm	6.34mm	3/4" (19.05mm)
SC4125	41mm	25mm	6.34mm	3/4" (19.05mm)
SC4225	42mm	25mm	6.34mm	3/4" (19.05mm)
SC4325	43mm	25mm	6.34mm	3/4" (19.05mm)
SC4425	44mm	25mm	6.34mm	3/4" (19.05mm)
SC4525	45mm	25mm	6.34mm	3/4" (19.05mm)
SC4625	46mm	25mm	6.34mm	3/4" (19.05mm)
SC4725	47mm	25mm	6.34mm	3/4" (19.05mm)
SC4825	48mm	25mm	6.34mm	3/4" (19.05mm)
SC4925	49mm	25mm	6.34mm	3/4" (19.05mm)
SC5025	50mm	25mm	6.34mm	3/4" (19.05mm)
SC5125	51mm	25mm	6.34mm	3/4" (19.05mm)
SC5225	52mm	25mm	6.34mm	3/4" (19.05mm)

4.70mm Pilot Pin to suit - Part# SP16001

6.34mm Pilot Pin to suit - Part# SP16003

METRIC SUPER-CUT 50MM DEPTH OF CUT

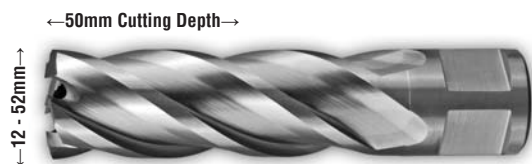

Part No.	Diameter	Depth Of Cut	Pilot Pin Diameter	Shank Diameter
SC1250	12mm	50mm	4.70mm	3/4" (19.05mm)
SC1350	13mm	50mm	4.70mm	3/4" (19.05mm)
SC1450	14mm	50mm	4.70mm	3/4" (19.05mm)
SC1550	15mm	50mm	6.34mm	3/4" (19.05mm)
SC1650	16mm	50mm	6.34mm	3/4" (19.05mm)
SC16.550	16.5mm	50mm	6.34mm	3/4" (19.05mm)
SC1750	17mm	50mm	6.34mm	3/4" (19.05mm)
SC1850	18mm	50mm	6.34mm	3/4" (19.05mm)
SC1950	19mm	50mm	6.34mm	3/4" (19.05mm)
SC2050	20mm	50mm	6.34mm	3/4" (19.05mm)
SC2150	21mm	50mm	6.34mm	3/4" (19.05mm)
SC2250	22mm	50mm	6.34mm	3/4" (19.05mm)
SC2350	23mm	50mm	6.34mm	3/4" (19.05mm)
SC2450	24mm	50mm	6.34mm	3/4" (19.05mm)
SC2550	25mm	50mm	6.34mm	3/4" (19.05mm)
SC2650	26mm	50mm	6.34mm	3/4" (19.05mm)
SC2850	28mm	50mm	6.34mm	3/4" (19.05mm)
SC2950	29mm	50mm	6.34mm	3/4" (19.05mm)
SC3050	30mm	50mm	6.34mm	3/4" (19.05mm)
SC3150	31mm	50mm	6.34mm	3/4" (19.05mm)
SC3250	32mm	50mm	6.34mm	3/4" (19.05mm)
SC3350	33mm	50mm	6.34mm	3/4" (19.05mm)
SC3450	34mm	50mm	6.34mm	3/4" (19.05mm)
SC3550	35mm	50mm	6.34mm	3/4" (19.05mm)
SC3650	36mm	50mm	6.34mm	3/4" (19.05mm)
SC3750	37mm	50mm	6.34mm	3/4" (19.05mm)
SC3850	38mm	50mm	6.34mm	3/4" (19.05mm)
SC3950	39mm	50mm	6.34mm	3/4" (19.05mm)
SC4050	40mm	50mm	6.34mm	3/4" (19.05mm)
SC4150	41mm	50mm	6.34mm	3/4" (19.05mm)
SC4250	42mm	50mm	6.34mm	3/4" (19.05mm)
SC4350	43mm	50mm	6.34mm	3/4" (19.05mm)
SC4450	44mm	50mm	6.34mm	3/4" (19.05mm)
SC4550	45mm	50mm	6.34mm	3/4" (19.05mm)
SC4650	46mm	50mm	6.34mm	3/4" (19.05mm)
SC4750	47mm	50mm	6.34mm	3/4" (19.05mm)
SC4850	48mm	50mm	6.34mm	3/4" (19.05mm)
SC5050	50mm	50mm	6.34mm	3/4" (19.05mm)
SC5150	51mm	50mm	6.34mm	3/4" (19.05mm)
SC5250	52mm	50mm	6.34mm	3/4" (19.05mm)

4.70mm Pilot Pin to suit - Part# SP16002

6.34mm Pilot Pin to suit - Part# SP16004

METRIC SUPER-CUT 75MM DEPTH OF CUT



Part No.	Diameter	Depth Of Cut	Pilot Pin Diameter	Shank Diameter
SC2075	20mm	75mm	8mm	3/4" (19.05mm)
SC2575	25mm	75mm	8mm	3/4" (19.05mm)
SC2775	27mm	75mm	8mm	3/4" (19.05mm)
SC3075	30mm	75mm	8mm	3/4" (19.05mm)
SC3275	32mm	75mm	8mm	3/4" (19.05mm)

8mm Pilot Pin to suit - Part# SP18075

SUPER-CUT IMPERIAL CUTTERS



IMPERIAL SUPER-CUT 1" DEPTH OF CUT

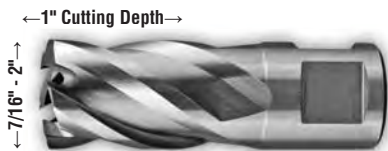

Part No.	Diameter	Depth Of Cut	Pilot Pin Diameter	Tap Size
SC7/16X1	7/16"	11.11mm	1"	4.70mm -
SC1/2X1	1/2"	12.70mm	1"	4.70mm -
SC9/16X1	9/16"	14.28mm	1"	6.34mm -
SC5/8X1	5/8"	15.87mm	1"	6.34mm 11/16" UNS
SC11/16X1	11/16"	17.46mm	1"	6.34mm -
SC3/4X1	3/4"	19.05mm	1"	6.34mm -
SC13/16X1	13/16"	20.64mm	1"	6.34mm -
SC7/8X1	7/8"	22.22mm	1"	6.34mm 1" UNC
SC1-1/8X1	1-1/8"	28.57mm	1"	6.34mm -
SC1-1/4X1	1-1/4"	31.75mm	1"	6.34mm -
SC1-5/16X1	1-5/16"	33.34mm	1"	6.34mm -
SC1-3/8X1	1-3/8"	34.92mm	1"	6.34mm -
SC1-1/2X1	1-1/2"	38.10mm	1"	6.34mm -
SC1-9/16X1	1-9/16"	39.69mm	1"	6.34mm -
SC1-5/8X1	1-5/8"	41.27mm	1"	6.34mm -
SC1-3/4X1	1-3/4"	44.45mm	1"	6.34mm -
SC1-7/8X1	1-7/8"	47.62mm	1"	6.34mm -
SC2X1	2"	50.80mm	1"	6.34mm -

3/4" (19.05mm) Shank Diameter
 4.70mm Pilot Pin to suit - Part# SP16001
 6.34mm Pilot Pin to suit - Part# SP16003

IMPERIAL SUPER-CUT 3" DEPTH OF CUT



Part No.	Diameter	Depth Of Cut	Pilot Pin Diameter	Tap Size	Shank Diameter
SC7/8X3	7/8"	22.22mm	3"	8mm	1" UNC 3/4" (19.05mm)
SC1X3	1"	25.40mm	3"	8mm	1-1/8" UNF 3/4" (19.05mm)
SC1-1/16X3	1-1/16"	26.99mm	3"	8mm	- 3/4" (19.05mm)
SC1-3/8X3	1-3/8"	34.92mm	3"	8mm	- 3/4" (19.05mm)
SC1-1/2X3	1-1/2"	38.10mm	3"	8mm	- 3/4" (19.05mm)
SC2-1/4X3	2-1/4"	57.15mm	3"	8mm	- 3/4" (19.05mm)
SC2-1/2X3B	2-1/2"	63.50mm	3"	8mm	- 1-1/4" (31.75mm)

8mm Pilot Pin to suit - Part# SP18075

IMPERIAL SUPER-CUT 2" DEPTH OF CUT

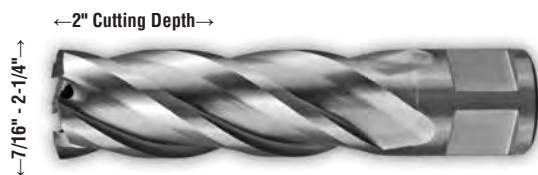

Part No.	Diameter	Depth Of Cut	Pilot Pin Diameter	Tap Size
SC7/16X2	7/16"	11.11mm	2"	4.70mm -
SC29/64X2	29/64"	11.51mm	2"	4.70mm 1/2" UNF
SC31/64X2	31/64"	12.30mm	2"	4.70mm 9/16" UNC
SC1/2X2	1/2"	12.70mm	2"	4.70mm -
SC9/16X2	9/16"	14.28mm	2"	6.34mm -
SC5/8X2	5/8"	15.87mm	2"	6.34mm 11/16" UNS
SC11/16X2	11/16"	17.46mm	2"	6.34mm 3/4" UNF
SC3/4X2	3/4"	19.05mm	2"	6.34mm -
SC49/64X2	49/64"	19.45mm	2"	6.34mm 7/8" UNC
SC51/64X2	51/64"	20.24mm	2"	6.34mm 7/8" UNF
SC13/16X2	13/16"	20.64mm	2"	6.34mm -
SC7/8X2	7/8"	22.22mm	2"	6.34mm 1" UNC
SC15/16X2	15/16"	23.81mm	2"	6.34mm -
SC1X2	1"	25.40mm	2"	6.34mm 1-1/8" UNF
SC1-11/64X2	1-11/64"	29.77mm	2"	6.34mm 1-1/4" UNF
SC1-1/4X2	1-1/4"	31.75mm	2"	6.34mm -
SC1-5/16X2	1-5/16"	33.34mm	2"	6.34mm -
SC1-3/8X2	1-3/8"	34.92mm	2"	6.34mm -
SC1-1/2X2	1-1/2"	38.10mm	2"	6.34mm -
SC1-9/16X2	1-9/16"	39.69mm	2"	6.34mm -
SC1-5/8X2	1-5/8"	41.27mm	2"	6.34mm -
SC1-7/8X2	1-7/8"	47.62mm	2"	6.34mm -
SC2X2	2"	50.80mm	2"	6.34mm -
SC2-1/16X2	2-1/16"	52.39mm	2"	6.34mm -
SC2-1/8X2	2-1/8"	53.97mm	2"	6.34mm -
SC2-1/4X2	2-1/4"	57.15mm	2"	6.34mm -

3/4" (19.05mm) Shank Diameter
 4.70mm Pilot Pin to suit - Part# SP16001
 6.34mm Pilot Pin to suit - Part# SP16003

SUPER-CUT CUTTER SETS



All sets include pilot pins

PART NO. SCSET-A | SHORT SERIES METRIC SET - 5 CUTTERS

Quantity	Part No.	Diameter	Depth Of Cut
1	SC1425	14mm	25mm
1	SC1625	16mm	25mm
1	SC1825	18mm	25mm
1	SC2025	20mm	25mm
1	SC2225	22mm	25mm

PART NO. SCSET-B | SHORT SERIES METRIC SET - 10 CUTTERS

1	SC1225	12mm	25mm
1	SC1325	13mm	25mm
1	SC1425	14mm	25mm
1	SC1625	16mm	25mm
1	SC1725	17mm	25mm
1	SC1825	18mm	25mm
1	SC2025	20mm	25mm
1	SC2225	22mm	25mm
1	SC2425	24mm	25mm
1	SC2625	26mm	25mm

PART NO. SCSET-C | LONG SERIES METRIC SET - 5 CUTTERS

1	SC1450	14mm	50mm
1	SC1650	16mm	50mm
1	SC1850	18mm	50mm
1	SC2050	20mm	50mm
1	SC2250	22mm	50mm

PART NO. SCSET-D | COMBINATION METRIC SET - 10 CUTTERS

Quantity	Part No.	Diameter	Depth Of Cut
1	SC1425	14mm	25mm
1	SC1625	16mm	25mm
1	SC1825	18mm	25mm
1	SC2025	20mm	25mm
1	SC2225	22mm	25mm
1	SC1450	14mm	50mm
1	SC1650	16mm	50mm
1	SC1850	18mm	50mm
1	SC2050	20mm	50mm
1	SC2250	22mm	50mm

PART NO. SCSET-E | SHORT SERIES IMPERIAL SET - 5 CUTTERS

1	SC1/2X1	1/2"	1"
1	SC5/8X1	5/8"	1"
1	SC3/4X1	3/4"	1"
1	SC7/8X1	7/8"	1"
1	SC1X1	1"	1"

PART NO. SCSET-F | COMBINATION IMPERIAL SET - 10 CUTTERS

1	SC1/2X1	1/2"	1"
1	SC5/8X1	5/8"	1"
1	SC3/4X1	3/4"	1"
1	SC7/8X1	7/8"	1"
1	SC1X1	1"	1"
1	SC1/2X2	1/2"	2"
1	SC5/8X2	5/8"	2"
1	SC3/4X2	3/4"	2"
1	SC7/8X2	7/8"	2"
1	SC1X2	1"	2"

PART NO. SCSET-G | SHORT SERIES METRIC SET - 6 CUTTERS

1	SC1325	13mm	25mm
1	SC1425	14mm	25mm
1	SC1625	16mm	25mm
1	SC1825	18mm	25mm
1	SC2225	22mm	25mm
1	SC2625	26mm	25mm

PART NO. SCSET-K | LONG SERIES METRIC SET - 6 CUTTERS

1	SC1350	13mm	50mm
1	SC1450	14mm	50mm
1	SC1650	16mm	50mm
1	SC1850	18mm	50mm
1	SC2250	22mm	50mm
1	SC2650	26mm	50mm

PART NO. SCSET-COSG | CHASSIS CUTTER SET - 6 CUTTERS

1	SC1/2X1COSG	1/2"	1"
1	SC9/16X1COSG	9/16"	1"
1	SC5/8X1COSG	5/8"	1"
1	SC3/4X1COSG	3/4"	1"
1	SC7/8X1COSG	7/8"	1"
1	SC1X1COSG	1"	1"

Magnetic
Base
Drilling
Machines

Cutting
Tools

Clamps

Engineer's
Tools

Sharpening
Machines

Metal
Cutting
Saws

Drilling
Machines

Bevelling
Machines
& Welding
Carriages

Punches
& Shears

Grinding
Machines

Fans &
Ventilators

Workshop
Storage

M7
Airtools

NPK
Airtools

Pneumatic
Products

SUPER-CUT COBALT M42



MADE IN U.S.A

M42 High Speed Steel with 8% Cobalt

Cobalt M42 suitable for hardened steel up to 350BNH (38HRC) ie: hard steels or steel with 'hard spots'.

Titanium nitride coating (gold colour) has a hardness of 85HRC and coating thickness of 1-3 microns thus providing a harder surface, and reduced friction, giving longer life.

SUPER-CUT COBALT 1" DEPTH OF CUT



Part No.	Diameter	Depth Of Cut	Pilot Pin Diameter	Shank Diameter
SC3/4X1CTN	3/4"	1"	6.34mm	3/4" (19.05mm)
SC7/8X1CTN	7/8"	1"	6.34mm	3/4" (19.05mm)
SC1X1CTN	1"	1"	6.34mm	3/4" (19.05mm)

6.34mm Pilot Pin to suit - Part# SP16003

SUPER-CUT CHASSIS CUTTER



MADE IN U.S.A

M42 Cobalt Cutter with Stack Grinding

Stack grinding allows the cutter to go through 2 or more layers of material in one pass. These cutters are ideally suited for drilling truck chassis.

SUPER-CUT CHASSIS 1" DEPTH OF CUT

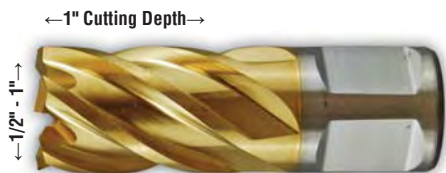

Part No.	Diameter	Depth Of Cut	Pilot Pin Diameter	Shank Diameter
SC1/2X1COSG	1/2"	1"	4.70mm	3/4" (19.05mm)
SC9/16X1COSG	9/16"	1"	6.34mm	3/4" (19.05mm)
SC5/8X1COSG	5/8"	1"	6.34mm	3/4" (19.05mm)
SC3/4X1COSG	3/4"	1"	6.34mm	3/4" (19.05mm)
SC7/8X1COSG	7/8"	1"	6.34mm	3/4" (19.05mm)
SC1X1COSG	1"	1"	6.34mm	3/4" (19.05mm)

4.70mm Pilot Pin to suit - Part# SP16001
6.34mm Pilot Pin to suit - Part# SP16003

SUPER-CUT TICN COATED



MADE IN U.S.A

Titanium Carbon Nitride Coated

TiCN coating (blue/grey in colour) is harder and tougher than other coating materials. Consequently it has high resistance to edge chipping and abrasive wear.

TiCN coating has a hardness of 90HRC and a coating thickness of 3 - 5 microns. Suitable for abrasive & difficult materials, e.g. : stainless steel, cast iron, SI-aluminium alloys.

SUPER-CUT TICN 25MM DEPTH OF CUT



Part No.	Diameter	Depth Of Cut	Pilot Pin Diameter	Shank Diameter
SC1225TICN	12mm	25mm	4.70mm	3/4" (19.05mm)
SC1425TICN	14mm	25mm	4.70mm	3/4" (19.05mm)
SC1825TICN	18mm	25mm	6.34mm	3/4" (19.05mm)
SC2025TICN	20mm	25mm	6.34mm	3/4" (19.05mm)
SC2425TICN	24mm	25mm	6.34mm	3/4" (19.05mm)
SC2625TICN	26mm	25mm	6.34mm	3/4" (19.05mm)
SC2825TICN	28mm	25mm	6.34mm	3/4" (19.05mm)
SC3025TICN	30mm	25mm	6.34mm	3/4" (19.05mm)
SC3225TICN	32mm	25mm	6.34mm	3/4" (19.05mm)

4.70mm Pilot Pin to suit - Part# SP16001

6.34mm Pilot Pin to suit - Part# SP16003

SUPER-CUT TICN 50MM DEPTH OF CUT

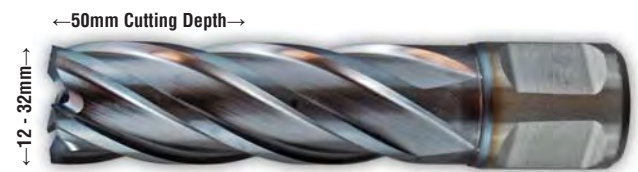

Part No.	Diameter	Depth Of Cut	Pilot Pin Diameter	Shank Diameter
SC1250TICN	12mm	50mm	4.70mm	3/4" (19.05mm)
SC1450TICN	14mm	50mm	4.70mm	3/4" (19.05mm)
SC1650TICN	16mm	50mm	6.34mm	3/4" (19.05mm)
SC2050TICN	20mm	50mm	6.34mm	3/4" (19.05mm)
SC2250TICN	22mm	50mm	6.34mm	3/4" (19.05mm)
SC2450TICN	24mm	50mm	6.34mm	3/4" (19.05mm)
SC2650TICN	26mm	50mm	6.34mm	3/4" (19.05mm)
SC2850TICN	28mm	50mm	6.34mm	3/4" (19.05mm)
SC3050TICN	30mm	50mm	6.34mm	3/4" (19.05mm)
SC3250TICN	32mm	50mm	6.34mm	3/4" (19.05mm)

4.70mm Pilot Pin to suit - Part# SP16001
6.34mm Pilot Pin to suit - Part# SP16003

PRO-CUT ASP® POWDER STEEL

Pro-Cut ASP® powder steel cutters offer incredible wear resistance & ductility.

ASP® steels are produced by powder metallurgy through a 3-step process: gas-atomisation, hot isostatic pressing and post processing operations such as forging, rolling or drawing.

Suitable for drilling railway line, stainless steel & hardened steels, where high wear resistance and lifetime are required.

- Incredible wear resistance
- Uniform micro structure
- Less susceptible to breakage

PRO-CUT 25MM DEPTH OF CUT



Part No.	Diameter	Depth Of Cut	Pilot Pin Diameter	Shank Diameter
PC1225	12mm	25mm	6.34mm	3/4" (19.05mm)
PC1325	13mm	25mm	6.34mm	3/4" (19.05mm)
PC1425	14mm	25mm	6.34mm	3/4" (19.05mm)
PC1625	16mm	25mm	6.34mm	3/4" (19.05mm)
PC1825	18mm	25mm	6.34mm	3/4" (19.05mm)
PC1925	19mm	25mm	6.34mm	3/4" (19.05mm)
PC2025	20mm	25mm	6.34mm	3/4" (19.05mm)
PC2225	22mm	25mm	6.34mm	3/4" (19.05mm)

6.34mm Pilot Pin to suit - Part# SP16003

PRO-CUT 50MM DEPTH OF CUT



Part No.	Diameter	Depth Of Cut	Pilot Pin Diameter	Shank Diameter
PC1250	12mm	50mm	6.34mm	3/4" (19.05mm)
PC1350	13mm	50mm	6.34mm	3/4" (19.05mm)
PC1450	14mm	50mm	6.34mm	3/4" (19.05mm)
PC1650	16mm	50mm	6.34mm	3/4" (19.05mm)
PC1850	18mm	50mm	6.34mm	3/4" (19.05mm)
PC1950	19mm	50mm	6.34mm	3/4" (19.05mm)
PC2050	20mm	50mm	6.34mm	3/4" (19.05mm)
PC2250	22mm	50mm	6.34mm	3/4" (19.05mm)

6.34mm Pilot Pin to suit - Part# SP16004

Performance of the Holemaker PRO-CUT Annular Cutter versus standard annular cutters when cutting 500BHN plate steel. The comparison video can be viewed at : www.holemaker.com/pro-cut.html



- | | |
|---|---|
| PRO-CUT Annular Cutters <ul style="list-style-type: none"> • Minimal wear • Optimal life | Standard Cutters <ul style="list-style-type: none"> • Cutter burnt out • High wear |
|---|---|

MAXI-CUT METRIC CUTTERS

Tungsten Carbide Tipped Annular Cutters

As well as providing excellent life in mild steel, Tungsten Carbide Tipped Cutters are suitable for drilling difficult materials eg. stainless steel, Bialloy and wear plate.

These Tungsten Carbide Tipped Cutters consist of an alloy metal body, and tungsten carbide cutting teeth. Due to this composition, these cutters are less susceptible to breakage than standard high speed steel cutters, especially in larger diameters and longer lengths.

The tungsten carbide cutting teeth can also be sharpened and replaced.

Large range available in sizes 12-150mm diameters, and lengths up to 150mm.

METRIC MAXI-CUT 35MM DEPTH OF CUT



Part No.	Diameter	Depth Of Cut	Pilot Pin Diameter	Shank Diameter
MAX35-12	12mm	35mm	6.34mm	3/4" (19.05mm)
MAX35-13	13mm	35mm	6.34mm	3/4" (19.05mm)
MAX35-14	14mm	35mm	6.34mm	3/4" (19.05mm)
MAX35-15	15mm	35mm	6.34mm	3/4" (19.05mm)
MAX35-16	16mm	35mm	6.34mm	3/4" (19.05mm)
MAX35-17	17mm	35mm	6.34mm	3/4" (19.05mm)
MAX35-18	18mm	35mm	8mm	3/4" (19.05mm)
MAX35-19	19mm	35mm	8mm	3/4" (19.05mm)
MAX35-20	20mm	35mm	8mm	3/4" (19.05mm)
MAX35-21	21mm	35mm	8mm	3/4" (19.05mm)
MAX35-22	22mm	35mm	8mm	3/4" (19.05mm)
MAX35-23	23mm	35mm	8mm	3/4" (19.05mm)
MAX35-24	24mm	35mm	8mm	3/4" (19.05mm)
MAX35-25	25mm	35mm	8mm	3/4" (19.05mm)
MAX35-26	26mm	35mm	8mm	3/4" (19.05mm)
MAX35-27	27mm	35mm	8mm	3/4" (19.05mm)
MAX35-28	28mm	35mm	8mm	3/4" (19.05mm)
MAX35-29	29mm	35mm	8mm	3/4" (19.05mm)
MAX35-30	30mm	35mm	8mm	3/4" (19.05mm)
MAX35-31	31mm	35mm	8mm	3/4" (19.05mm)
MAX35-32	32mm	35mm	8mm	3/4" (19.05mm)
MAX35-35	35mm	35mm	8mm	3/4" (19.05mm)
MAX35-36	36mm	35mm	8mm	3/4" (19.05mm)
MAX35-38	38mm	35mm	8mm	3/4" (19.05mm)
MAX35-40	40mm	35mm	8mm	3/4" (19.05mm)

6.34mm Pilot Pin to suit - Part# SP16015

8mm Pilot Pin to suit - Part# SP18035

METRIC MAXI-CUT 50MM DEPTH OF CUT

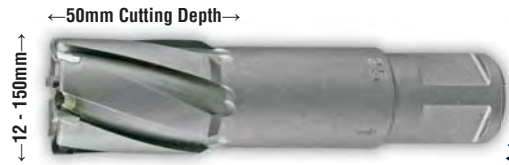

Part No.	Diameter	Depth Of Cut	Pilot Pin Diameter	Shank Diameter
3/4" SHANK TYPE				
MAX50-12	12mm	50mm	6.34mm	3/4" (19.05mm)
MAX50-13	13mm	50mm	6.34mm	3/4" (19.05mm)
MAX50-14	14mm	50mm	6.34mm	3/4" (19.05mm)
MAX50-15	15mm	50mm	6.34mm	3/4" (19.05mm)
MAX50-16	16mm	50mm	6.34mm	3/4" (19.05mm)
MAX50-17	17mm	50mm	6.34mm	3/4" (19.05mm)
MAX50-18	18mm	50mm	8mm	3/4" (19.05mm)
MAX50-19	19mm	50mm	8mm	3/4" (19.05mm)
MAX50-20	20mm	50mm	8mm	3/4" (19.05mm)
MAX50-21	21mm	50mm	8mm	3/4" (19.05mm)
MAX50-22	22mm	50mm	8mm	3/4" (19.05mm)
MAX50-23	23mm	50mm	8mm	3/4" (19.05mm)
MAX50-24	24mm	50mm	8mm	3/4" (19.05mm)
MAX50-25	25mm	50mm	8mm	3/4" (19.05mm)
MAX50-26	26mm	50mm	8mm	3/4" (19.05mm)
MAX50-27	27mm	50mm	8mm	3/4" (19.05mm)
MAX50-28	28mm	50mm	8mm	3/4" (19.05mm)
MAX50-29	29mm	50mm	8mm	3/4" (19.05mm)
MAX50-30	30mm	50mm	8mm	3/4" (19.05mm)
MAX50-31	31mm	50mm	8mm	3/4" (19.05mm)
MAX50-32	32mm	50mm	8mm	3/4" (19.05mm)
MAX50-33	33mm	50mm	8mm	3/4" (19.05mm)
MAX50-34	34mm	50mm	8mm	3/4" (19.05mm)
MAX50-35	35mm	50mm	8mm	3/4" (19.05mm)
MAX50-36	36mm	50mm	8mm	3/4" (19.05mm)
MAX50-37	37mm	50mm	8mm	3/4" (19.05mm)
MAX50-38	38mm	50mm	8mm	3/4" (19.05mm)
MAX50-39	39mm	50mm	8mm	3/4" (19.05mm)
MAX50-40	40mm	50mm	8mm	3/4" (19.05mm)
MAX50-41	41mm	50mm	8mm	3/4" (19.05mm)
MAX50-42	42mm	50mm	8mm	3/4" (19.05mm)
MAX50-43	43mm	50mm	8mm	3/4" (19.05mm)
MAX50-44	44mm	50mm	8mm	3/4" (19.05mm)
MAX50-45	45mm	50mm	8mm	3/4" (19.05mm)
MAX50-46	46mm	50mm	8mm	3/4" (19.05mm)
MAX50-47	47mm	50mm	8mm	3/4" (19.05mm)
MAX50-48	48mm	50mm	8mm	3/4" (19.05mm)
MAX50-49	49mm	50mm	8mm	3/4" (19.05mm)
MAX50-50	50mm	50mm	8mm	3/4" (19.05mm)
MAX50-51	51mm	50mm	8mm	3/4" (19.05mm)
MAX50-52	52mm	50mm	8mm	3/4" (19.05mm)
MAX50-53	53mm	50mm	8mm	3/4" (19.05mm)
MAX50-54	54mm	50mm	8mm	3/4" (19.05mm)

6.34mm Pilot Pin to suit - Part# SP16004

8mm Pilot Pin to suit - Part# SP18050

METRIC MAXI-CUT 50MM DEPTH OF CUT

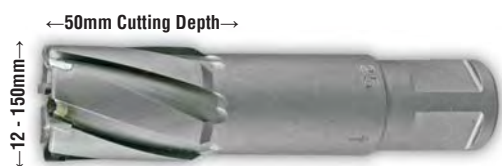

Part No.	Diameter	Depth Of Cut	Pilot Pin Diameter	Shank Diameter
3/4" SHANK TYPE				
MAX50-55	55mm	50mm	8mm	3/4" (19.05mm)
MAX50-56	56mm	50mm	8mm	3/4" (19.05mm)
MAX50-57	57mm	50mm	8mm	3/4" (19.05mm)
MAX50-58	58mm	50mm	8mm	3/4" (19.05mm)
MAX50-59	59mm	50mm	8mm	3/4" (19.05mm)
MAX50-60A	60mm	50mm	8mm	3/4" (19.05mm)
MAX50-61A	61mm	50mm	8mm	3/4" (19.05mm)
MAX50-62A	62mm	50mm	8mm	3/4" (19.05mm)
MAX50-63A	63mm	50mm	8mm	3/4" (19.05mm)
MAX50-64A	64mm	50mm	8mm	3/4" (19.05mm)
MAX50-65A	65mm	50mm	8mm	3/4" (19.05mm)
MAX50-66A	66mm	50mm	8mm	3/4" (19.05mm)
MAX50-67A	67mm	50mm	8mm	3/4" (19.05mm)
MAX50-68A	68mm	50mm	8mm	3/4" (19.05mm)
MAX50-69A	69mm	50mm	8mm	3/4" (19.05mm)
MAX50-70A	70mm	50mm	8mm	3/4" (19.05mm)
MAX50-71A	71mm	50mm	8mm	3/4" (19.05mm)
MAX50-72A	72mm	50mm	8mm	3/4" (19.05mm)
MAX50-73A	73mm	50mm	8mm	3/4" (19.05mm)
MAX50-74A	74mm	50mm	8mm	3/4" (19.05mm)
MAX50-75A	75mm	50mm	8mm	3/4" (19.05mm)

8mm Pilot Pin to suit - Part# SP18050

METRIC MAXI-CUT 50MM DEPTH OF CUT

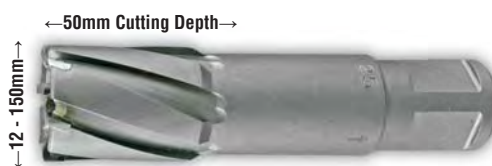

Part No.	Diameter	Depth Of Cut	Pilot Pin Diameter	Shank Diameter
1-1/4" SHANK TYPE				
MAX50-60B	60mm	50mm	8mm	1-1/4" (31.75mm)
MAX50-61B	61mm	50mm	8mm	1-1/4" (31.75mm)
MAX50-62B	62mm	50mm	8mm	1-1/4" (31.75mm)
MAX50-63B	63mm	50mm	8mm	1-1/4" (31.75mm)
MAX50-64B	64mm	50mm	8mm	1-1/4" (31.75mm)
MAX50-65B	65mm	50mm	8mm	1-1/4" (31.75mm)
MAX50-66B	66mm	50mm	8mm	1-1/4" (31.75mm)
MAX50-67B	67mm	50mm	8mm	1-1/4" (31.75mm)
MAX50-68B	68mm	50mm	8mm	1-1/4" (31.75mm)
MAX50-69B	69mm	50mm	8mm	1-1/4" (31.75mm)
MAX50-70B	70mm	50mm	8mm	1-1/4" (31.75mm)
MAX50-71B	71mm	50mm	8mm	1-1/4" (31.75mm)
MAX50-72B	72mm	50mm	8mm	1-1/4" (31.75mm)
MAX50-73B	73mm	50mm	8mm	1-1/4" (31.75mm)
MAX50-74B	74mm	50mm	8mm	1-1/4" (31.75mm)
MAX50-75B	75mm	50mm	8mm	1-1/4" (31.75mm)
MAX50-76B	76mm	50mm	8mm	1-1/4" (31.75mm)
MAX50-77B	77mm	50mm	8mm	1-1/4" (31.75mm)
MAX50-78B	78mm	50mm	8mm	1-1/4" (31.75mm)
MAX50-79B	79mm	50mm	8mm	1-1/4" (31.75mm)
MAX50-80B	80mm	50mm	8mm	1-1/4" (31.75mm)
MAX50-81B	81mm	50mm	8mm	1-1/4" (31.75mm)
MAX50-82B	82mm	50mm	8mm	1-1/4" (31.75mm)
MAX50-83B	83mm	50mm	8mm	1-1/4" (31.75mm)
MAX50-84B	84mm	50mm	8mm	1-1/4" (31.75mm)
MAX50-85B	85mm	50mm	8mm	1-1/4" (31.75mm)
MAX50-86B	86mm	50mm	8mm	1-1/4" (31.75mm)
MAX50-87B	87mm	50mm	8mm	1-1/4" (31.75mm)
MAX50-88B	88mm	50mm	8mm	1-1/4" (31.75mm)
MAX50-89B	89mm	50mm	8mm	1-1/4" (31.75mm)
MAX50-90B	90mm	50mm	8mm	1-1/4" (31.75mm)
MAX50-92B	92mm	50mm	8mm	1-1/4" (31.75mm)
MAX50-95B	95mm	50mm	8mm	1-1/4" (31.75mm)
MAX50-98B	98mm	50mm	8mm	1-1/4" (31.75mm)
MAX50-100B	100mm	50mm	8mm	1-1/4" (31.75mm)
MAX50-102B	102mm	50mm	8mm	1-1/4" (31.75mm)
MAX50-105B	105mm	50mm	8mm	1-1/4" (31.75mm)
MAX50-110B	110mm	50mm	8mm	1-1/4" (31.75mm)
MAX50-115B	115mm	50mm	8mm	1-1/4" (31.75mm)
MAX50-120B	120mm	50mm	8mm	1-1/4" (31.75mm)
MAX50-125B	125mm	50mm	8mm	1-1/4" (31.75mm)
MAX50-130B	130mm	50mm	8mm	1-1/4" (31.75mm)
MAX50-135B	135mm	50mm	8mm	1-1/4" (31.75mm)
MAX50-140B	140mm	50mm	8mm	1-1/4" (31.75mm)
MAX50-145B	145mm	50mm	8mm	1-1/4" (31.75mm)
MAX50-150B	150mm	50mm	8mm	1-1/4" (31.75mm)

8mm Pilot Pin to suit - Part# SP18050

METRIC MAXI-CUT 75MM DEPTH OF CUT

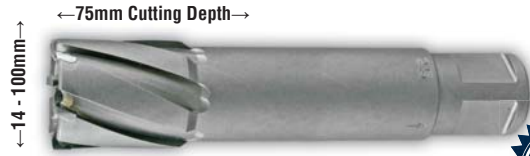

Part No.	Diameter	Depth Of Cut	Pilot Pin Diameter	Shank Diameter
3/4" SHANK TYPE				
MAX75-14	14mm	75mm	6.34mm	3/4" (19.05mm)
MAX75-15	15mm	75mm	6.34mm	3/4" (19.05mm)
MAX75-16	16mm	75mm	6.34mm	3/4" (19.05mm)
MAX75-17	17mm	75mm	6.34mm	3/4" (19.05mm)
MAX75-18	18mm	75mm	8mm	3/4" (19.05mm)
MAX75-19	19mm	75mm	8mm	3/4" (19.05mm)
MAX75-20	20mm	75mm	8mm	3/4" (19.05mm)
MAX75-22	22mm	75mm	8mm	3/4" (19.05mm)
MAX75-24	24mm	75mm	8mm	3/4" (19.05mm)
MAX75-25	25mm	75mm	8mm	3/4" (19.05mm)
MAX75-26	26mm	75mm	8mm	3/4" (19.05mm)
MAX75-28	28mm	75mm	8mm	3/4" (19.05mm)
MAX75-30	30mm	75mm	8mm	3/4" (19.05mm)
MAX75-32	32mm	75mm	8mm	3/4" (19.05mm)
MAX75-33	33mm	75mm	8mm	3/4" (19.05mm)
MAX75-34	34mm	75mm	8mm	3/4" (19.05mm)
MAX75-35	35mm	75mm	8mm	3/4" (19.05mm)
MAX75-36	36mm	75mm	8mm	3/4" (19.05mm)
MAX75-38	38mm	75mm	8mm	3/4" (19.05mm)
MAX75-40	40mm	75mm	8mm	3/4" (19.05mm)
MAX75-42	42mm	75mm	8mm	3/4" (19.05mm)
MAX75-45	45mm	75mm	8mm	3/4" (19.05mm)
MAX75-50	50mm	75mm	8mm	3/4" (19.05mm)
MAX75-50.5	50.5mm	75mm	8mm	3/4" (19.05mm)
MAX75-52	52mm	75mm	8mm	3/4" (19.05mm)
MAX75-55	55mm	75mm	8mm	3/4" (19.05mm)
1-1/4" SHANK TYPE				
MAX75-60B	60mm	75mm	8mm	1-1/4" (31.75mm)
MAX75-60.5B	60.5mm	75mm	8mm	1-1/4" (31.75mm)
MAX75-64B	64mm	75mm	8mm	1-1/4" (31.75mm)
MAX75-65B	65mm	75mm	8mm	1-1/4" (31.75mm)
MAX75-67B	67mm	75mm	8mm	1-1/4" (31.75mm)
MAX75-68B	68mm	75mm	8mm	1-1/4" (31.75mm)
MAX75-70B	70mm	75mm	8mm	1-1/4" (31.75mm)
MAX75-73B	73mm	75mm	8mm	1-1/4" (31.75mm)
MAX75-75B	75mm	75mm	8mm	1-1/4" (31.75mm)
MAX75-80B	80mm	75mm	8mm	1-1/4" (31.75mm)
MAX75-85B	85mm	75mm	8mm	1-1/4" (31.75mm)
MAX75-90B	90mm	75mm	8mm	1-1/4" (31.75mm)
MAX75-95B	95mm	75mm	8mm	1-1/4" (31.75mm)
MAX75-100B	100mm	75mm	8mm	1-1/4" (31.75mm)

6.34mm Pilot Pin to suit - Part# SP16005
8mm Pilot Pin to suit - Part # SP18075

METRIC MAXI-CUT 100MM DEPTH OF CUT



Part No.	Diameter	Depth Of Cut	Pilot Pin Diameter	Shank Diameter
3/4" SHANK TYPE				
MAX100-14	14mm	100mm	6.34mm	3/4" (19.05mm)
MAX100-15	15mm	100mm	6.34mm	3/4" (19.05mm)
MAX100-16	16mm	100mm	6.34mm	3/4" (19.05mm)
MAX100-17	17mm	100mm	6.34mm	3/4" (19.05mm)
MAX100-18	18mm	100mm	8mm	3/4" (19.05mm)
MAX100-19	19mm	100mm	8mm	3/4" (19.05mm)
MAX100-20	20mm	100mm	8mm	3/4" (19.05mm)
MAX100-21	21mm	100mm	8mm	3/4" (19.05mm)
MAX100-22	22mm	100mm	8mm	3/4" (19.05mm)
MAX100-23	23mm	100mm	8mm	3/4" (19.05mm)
MAX100-24	24mm	100mm	8mm	3/4" (19.05mm)
MAX100-25	25mm	100mm	8mm	3/4" (19.05mm)
MAX100-26	26mm	100mm	8mm	3/4" (19.05mm)
MAX100-27	27mm	100mm	8mm	3/4" (19.05mm)
MAX100-28	28mm	100mm	8mm	3/4" (19.05mm)
MAX100-29	29mm	100mm	8mm	3/4" (19.05mm)
MAX100-30	30mm	100mm	8mm	3/4" (19.05mm)
MAX100-31	31mm	100mm	8mm	3/4" (19.05mm)
MAX100-32	32mm	100mm	8mm	3/4" (19.05mm)
MAX100-33	33mm	100mm	8mm	3/4" (19.05mm)
MAX100-34	34mm	100mm	8mm	3/4" (19.05mm)
MAX100-35	35mm	100mm	8mm	3/4" (19.05mm)
MAX100-36	36mm	100mm	8mm	3/4" (19.05mm)
MAX100-37	37mm	100mm	8mm	3/4" (19.05mm)
MAX100-38	38mm	100mm	8mm	3/4" (19.05mm)
MAX100-39	39mm	100mm	8mm	3/4" (19.05mm)
MAX100-40	40mm	100mm	8mm	3/4" (19.05mm)
MAX100-41	41mm	100mm	8mm	3/4" (19.05mm)
MAX100-42	42mm	100mm	8mm	3/4" (19.05mm)
MAX100-43	43mm	100mm	8mm	3/4" (19.05mm)
MAX100-44	44mm	100mm	8mm	3/4" (19.05mm)
MAX100-45	45mm	100mm	8mm	3/4" (19.05mm)
MAX100-46	46mm	100mm	8mm	3/4" (19.05mm)
MAX100-47	47mm	100mm	8mm	3/4" (19.05mm)
MAX100-48	48mm	100mm	8mm	3/4" (19.05mm)
MAX100-49	49mm	100mm	8mm	3/4" (19.05mm)
MAX100-50	50mm	100mm	8mm	3/4" (19.05mm)
MAX100-51	51mm	100mm	8mm	3/4" (19.05mm)
MAX100-52	52mm	100mm	8mm	3/4" (19.05mm)
MAX100-53	53mm	100mm	8mm	3/4" (19.05mm)
MAX100-54	54mm	100mm	8mm	3/4" (19.05mm)
MAX100-55	55mm	100mm	8mm	3/4" (19.05mm)
MAX100-56	56mm	100mm	8mm	3/4" (19.05mm)
MAX100-57	57mm	100mm	8mm	3/4" (19.05mm)
MAX100-58	58mm	100mm	8mm	3/4" (19.05mm)
MAX100-59	59mm	100mm	8mm	3/4" (19.05mm)
MAX100-60	60mm	100mm	8mm	3/4" (19.05mm)

6.34mm Pilot Pin to suit - Part# SP16009
8mm Pilot Pin to suit - Part # SP18100

METRIC MAXI-CUT 100MM DEPTH OF CUT

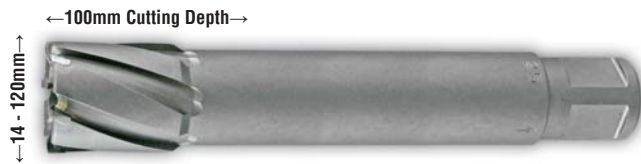

METRIC MAXI-CUT 150MM DEPTH OF CUT



Part No.	Diameter	Depth Of Cut	Pilot Pin Diameter	Shank Diameter
1-1/4" SHANK TYPE				
MAX100-61B	61mm	100mm	8mm	1-1/4" (31.75mm)
MAX100-62B	62mm	100mm	8mm	1-1/4" (31.75mm)
MAX100-63B	63mm	100mm	8mm	1-1/4" (31.75mm)
MAX100-64B	64mm	100mm	8mm	1-1/4" (31.75mm)
MAX100-65B	65mm	100mm	8mm	1-1/4" (31.75mm)
MAX100-66B	66mm	100mm	8mm	1-1/4" (31.75mm)
MAX100-67B	67mm	100mm	8mm	1-1/4" (31.75mm)
MAX100-68B	68mm	100mm	8mm	1-1/4" (31.75mm)
MAX100-69B	69mm	100mm	8mm	1-1/4" (31.75mm)
MAX100-70B	70mm	100mm	8mm	1-1/4" (31.75mm)
MAX100-71B	71mm	100mm	8mm	1-1/4" (31.75mm)
MAX100-72B	72mm	100mm	8mm	1-1/4" (31.75mm)
MAX100-73B	73mm	100mm	8mm	1-1/4" (31.75mm)
MAX100-74B	74mm	100mm	8mm	1-1/4" (31.75mm)
MAX100-75B	75mm	100mm	8mm	1-1/4" (31.75mm)
MAX100-76B	76mm	100mm	8mm	1-1/4" (31.75mm)
MAX100-77B	77mm	100mm	8mm	1-1/4" (31.75mm)
MAX100-78B	78mm	100mm	8mm	1-1/4" (31.75mm)
MAX100-79B	79mm	100mm	8mm	1-1/4" (31.75mm)
MAX100-80B	80mm	100mm	8mm	1-1/4" (31.75mm)
MAX100-81B	81mm	100mm	8mm	1-1/4" (31.75mm)
MAX100-82B	82mm	100mm	8mm	1-1/4" (31.75mm)
MAX100-83B	83mm	100mm	8mm	1-1/4" (31.75mm)
MAX100-84B	84mm	100mm	8mm	1-1/4" (31.75mm)
MAX100-85B	85mm	100mm	8mm	1-1/4" (31.75mm)
MAX100-86B	86mm	100mm	8mm	1-1/4" (31.75mm)
MAX100-87B	87mm	100mm	8mm	1-1/4" (31.75mm)
MAX100-88B	88mm	100mm	8mm	1-1/4" (31.75mm)
MAX100-89B	89mm	100mm	8mm	1-1/4" (31.75mm)
MAX100-90B	90mm	100mm	8mm	1-1/4" (31.75mm)
MAX100-92B	92mm	100mm	8mm	1-1/4" (31.75mm)
MAX100-95B	95mm	100mm	8mm	1-1/4" (31.75mm)
MAX100-100B	100mm	100mm	8mm	1-1/4" (31.75mm)
MAX100-102B	102mm	100mm	8mm	1-1/4" (31.75mm)
MAX100-105B	105mm	100mm	8mm	1-1/4" (31.75mm)
MAX100-110B	110mm	100mm	8mm	1-1/4" (31.75mm)
MAX100-115B	115mm	100mm	8mm	1-1/4" (31.75mm)
MAX100-120B	120mm	100mm	8mm	1-1/4" (31.75mm)

8mm Pilot Pin to suit - Part # SP18100

Part No.	Diameter	Depth Of Cut	Pilot Pin Diameter	Shank Diameter
3/4" SHANK TYPE				
MAX150-18	18mm	150mm	8mm	3/4" (19.05mm)
MAX150-19	19mm	150mm	8mm	3/4" (19.05mm)
MAX150-20	20mm	150mm	8mm	3/4" (19.05mm)
MAX150-22	22mm	150mm	8mm	3/4" (19.05mm)
MAX150-24	24mm	150mm	8mm	3/4" (19.05mm)
MAX150-25	25mm	150mm	8mm	3/4" (19.05mm)
MAX150-26	26mm	150mm	8mm	3/4" (19.05mm)
MAX150-28	28mm	150mm	8mm	3/4" (19.05mm)
MAX150-30	30mm	150mm	8mm	3/4" (19.05mm)
MAX150-32	32mm	150mm	8mm	3/4" (19.05mm)
MAX150-34	34mm	150mm	8mm	3/4" (19.05mm)
MAX150-35	35mm	150mm	8mm	3/4" (19.05mm)
MAX150-36	36mm	150mm	8mm	3/4" (19.05mm)
MAX150-38	38mm	150mm	8mm	3/4" (19.05mm)
MAX150-40	40mm	150mm	8mm	3/4" (19.05mm)
MAX150-42	42mm	150mm	8mm	3/4" (19.05mm)
MAX150-44	44mm	150mm	8mm	3/4" (19.05mm)
MAX150-45	45mm	150mm	8mm	3/4" (19.05mm)
MAX150-46	46mm	150mm	8mm	3/4" (19.05mm)
MAX150-48	48mm	150mm	8mm	3/4" (19.05mm)
MAX150-50	50mm	150mm	8mm	3/4" (19.05mm)
MAX150-51	51mm	150mm	8mm	3/4" (19.05mm)
MAX150-52	52mm	150mm	8mm	3/4" (19.05mm)
MAX150-54	54mm	150mm	8mm	3/4" (19.05mm)
MAX150-55	55mm	150mm	8mm	3/4" (19.05mm)
MAX150-56	56mm	150mm	8mm	3/4" (19.05mm)
MAX150-58	58mm	150mm	8mm	3/4" (19.05mm)
MAX150-60	60mm	150mm	8mm	3/4" (19.05mm)

8mm Pilot Pin to suit - Part # SP18150

MAXI-CUT IMPERIAL CUTTERS

Tungsten Carbide Tipped Annular Cutters

As well as providing excellent life in mild steel, Tungsten Carbide Tipped Annular Cutters are suitable for drilling difficult materials eg. stainless steel, Bisalloy and wear plate.

These Tungsten Carbide Tipped Cutters consist of an alloy metal body, and tungsten carbide cutting teeth. Due to this composition, these cutters are less susceptible to breakage than standard high speed steel cutters, especially in larger diameters and lengths.

The tungsten carbide cutting teeth can also be sharpened and replaced.

Large range available in sizes 5/8" to 2-1/2" diameters, and lengths up to 4".

IMPERIAL MAXI-CUT 2" DEPTH OF CUT

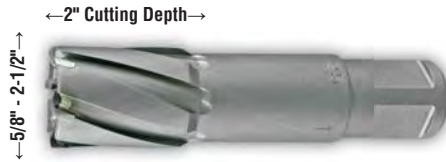

Part No.	Diameter	Depth Of Cut	Pilot Pin Diameter	Shank Diameter
MAX501-5/8	5/8"	15.87mm	2"	6.34mm
MAX501-3/4	3/4"	19.05mm	2"	6.34mm
MAX501-7/8	7/8"	22.22mm	2"	6.34mm
MAX501-1	1"	25.40mm	2"	6.34mm
MAX501-1-1/8	1-1/8"	28.57mm	2"	6.34mm
MAX501-1-1/4	1-1/4"	31.75mm	2"	6.34mm
MAX501-1-5/16	1-5/16"	33.34mm	2"	6.34mm
MAX501-1-3/8	1-3/8"	34.92mm	2"	6.34mm
MAX501-1-1/2	1-1/2"	38.10mm	2"	6.34mm
MAX501-1-5/8	1-5/8"	41.27mm	2"	6.34mm
MAX501-1-3/4	1-3/4"	44.45mm	2"	6.34mm
MAX501-1-7/8	1-7/8"	47.62mm	2"	6.34mm
MAX501-2	2"	50.80mm	2"	6.34mm
MAX501-2-1/8	2-1/8"	53.97mm	2"	6.34mm
MAX501-2-1/4	2-1/4"	57.15mm	2"	6.34mm
MAX501-2-3/8	2-3/8"	60.33mm	2"	6.34mm
MAX501-2-1/2	2-1/2"	63.50mm	2"	6.34mm

6.34mm Pilot Pin to suit - Part # SP16004

IMPERIAL MAXI-CUT 3" DEPTH OF CUT

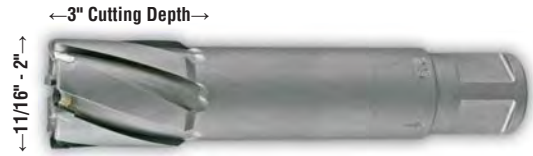

Part No.	Diameter	Depth Of Cut	Pilot Pin Diameter	Shank Diameter
MAX751-11/16	11/16"	17.46mm	3"	8mm
MAX751-3/4	3/4"	19.05mm	3"	8mm
MAX751-7/8	7/8"	22.22mm	3"	8mm
MAX751-1	1"	25.40mm	3"	8mm
MAX751-1-1/8	1-1/8"	28.57mm	3"	8mm
MAX751-1-1/4	1-1/4"	31.75mm	3"	8mm
MAX751-1-5/16	1-5/16"	33.34mm	3"	8mm
MAX751-1-3/8	1-3/8"	34.92mm	3"	8mm
MAX751-1-1/2	1-1/2"	38.10mm	3"	8mm
MAX751-1-5/8	1-5/8"	41.27mm	3"	8mm
MAX751-1-3/4	1-3/4"	44.45mm	3"	8mm
MAX751-1-7/8	1-7/8"	47.62mm	3"	8mm
MAX751-2	2"	50.80mm	3"	8mm

8mm Pilot Pin to suit - Part # SP18075

IMPERIAL MAXI-CUT 4" DEPTH OF CUT



Part No.	Diameter	Depth Of Cut	Pilot Pin Diameter	Shank Diameter
MAX1001-1	1"	25.4mm	4"	8mm

8mm Pilot Pin to suit - Part # SP18100

MAXI-RAIL

Tungsten Carbide Tipped specifically designed for drilling railway line & suitable for drilling other hard materials such as wear plate & Bisalloy.

METRIC MAXI-RAIL 25MM DEPTH OF CUT



Part No.	Diameter	Depth Of Cut	Pilot Pin Diameter	Shank Diameter
HMAIL1825	18mm	25mm	8mm	3/4" (19.05mm)
HMAIL2025	20mm	25mm	8mm	3/4" (19.05mm)
HMAIL2225	22mm	25mm	8mm	3/4" (19.05mm)
HMAIL2425	24mm	25mm	8mm	3/4" (19.05mm)
HMAIL2525	25mm	25mm	8mm	3/4" (19.05mm)
HMAIL2625	26mm	25mm	8mm	3/4" (19.05mm)
HMAIL2725	27mm	25mm	8mm	3/4" (19.05mm)
HMAIL2825	28mm	25mm	8mm	3/4" (19.05mm)
HMAIL3025	30mm	25mm	8mm	3/4" (19.05mm)
HMAIL3225	32mm	25mm	8mm	3/4" (19.05mm)
HMAIL3525	35mm	25mm	8mm	3/4" (19.05mm)

8mm Pilot Pin to suit - Part# SP18025

ASP-RAIL 25MM DEPTH OF CUT ASP® 2030 HSS POWDER STEEL

ASP® 2030 powder steel offers incredible wear resistance & ductility. ASP® steels are produced by powder metallurgy through a 3-step process: gas-atomisation, hot isostatic pressing and post processing operations such as forging, rolling or drawing.

Suitable for drilling railway line, stainless steel & hardened steels, where high wear resistance and lifetime are required.

- Incredible wear resistance
- Uniform micro structure
- Less susceptible to breakage



Part No.	Diameter	Depth Of Cut	Pilot Pin Diameter	Shank Diameter
HMAIL3225-ASP	32mm	25mm	6.34mm	3/4" (19.05mm)

6.34mm Pilot Pin to suit - Part# SP16003

COUNTERSINKS

- With 3/4" Weldon Shank for use in magnetic base drilling machines
- 3 flute high speed steel

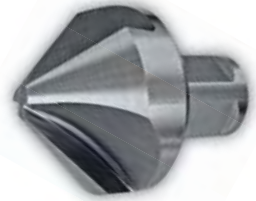

Part No.	Size Maximum	Angle	Shank Diameter
SCS90/30	30mm	90°	3/4" (19.05mm)
SCS90/40	40mm	90°	3/4" (19.05mm)
SCS90/55	55mm	90°	3/4" (19.05mm)

TWIST DRILLS & ADAPTORS

Adaptors allow the use of standard stub or jobber drills in magnetic base drilling machines.

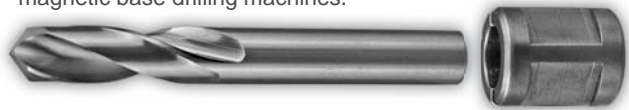

Part No.	Diameter	Part No.	Diameter
ADAPTORS		DRILL BITS	
METRIC			
SPTDA-6	6mm	SPTD-6	6mm
SPTDA-8	8mm	SPTD-8	8mm
SPTDA-10	10mm	SPTD-10	10mm
SPTDA-12	12mm	SPTD-12	12mm
IMPERIAL			
SPTDA-1/4	1/4"	SPTD-1/4	1/4"
SPTDA-5/16	5/16"	SPTD-5/16	5/16"
SPTDA-3/8	3/8"	SPTD-3/8	3/8"
SPTDA-7/16	7/16"	SPTD-7/16	7/16"
SPTDA-1/2	1/2"	SPTD-1/2	1/2"

TWIST DRILLS - WELDON SHANK



- 3/4" Weldon Shank for use in magnetic base drilling machines
- Designed to utilise through spindle coolant system, to provide coolant to the cutting edge



Part No.	Diameter	Depth Of Cut	Shank Size
METRIC			
SPTSD-06	6mm	30mm	3/4" (19.05mm)
SPTSD-08	8mm	30mm	3/4" (19.05mm)
SPTSD-10	10mm	30mm	3/4" (19.05mm)
SPTSD-12	12mm	30mm	3/4" (19.05mm)
SPTSD-13	13mm	30mm	3/4" (19.05mm)
SPTSD-16	16mm	30mm	3/4" (19.05mm)
SPTSD-18	18mm	30mm	3/4" (19.05mm)
IMPERIAL			
SPTSD-1/4	1/4"	30mm	3/4" (19.05mm)
SPTSD-5/16	5/16"	30mm	3/4" (19.05mm)
SPTSD-3/8	3/8"	30mm	3/4" (19.05mm)
SPTSD-7/16	7/16"	30mm	3/4" (19.05mm)
SPTSD-1/2	1/2"	30mm	3/4" (19.05mm)

CENTURAIL INDEXABLE INSERT DRILLS

- Solid rail cutter utilising 'SPMG' indexable carbide inserts providing high performance drilling through hard materials
- 3/4" Weldon Shank for use with Holemaker drills
- Internal coolant supply
- Ability to drill blind holes



Part No.	Diameter	Depth Of Cut	Insert Size
TSD-18	18mm	30mm	6mm
TSD-20	20mm	30mm	6mm
TSD-22	22mm	30mm	8mm
TSD-24	24mm	30mm	8mm
TSD-25	25mm	30mm	8mm
TSD-26	26mm	30mm	8mm
TSD-30	30mm	30mm	10mm
TSD-32	32mm	30mm	10mm
TSD-34	34mm	30mm	10mm
TSD-36	36mm	30mm	11.5mm

COMBINATION DRILL TAP

- Cobalt high speed steel (M35)
- 19.05mm (3/4") universal shank
- Maximum material thickness 10mm
- Will not give full thread depth so maximum torque strength cannot be applied



Part No.	Diameter	Drill Diameter	Overall Length
HMDT06	M6 X 1.0	5mm	110mm
HMDT08	M8 X 1.25	6.8mm	110mm
HMDT10	M10 X 1.5	8.5mm	113mm
HMDT12	M12 X 1.75	10.2mm	117mm
HMDT14	M14 X 2.0	12mm	117mm
HMDT16	M16 X 2.0	14mm	117mm
HMDT18	M18 X 2.5	16.5mm	130mm
HMDT20	M20 X 2.5	17.5mm	135mm
HMDT22	M22 X 2.5	19.5mm	135mm
HMDT24	M24 X 3.0	21.5mm	148mm
HMDT27	M27 X 3.0	24mm	155mm
HMDT30	M30 X 3.5	26.5mm	169mm

MINI CUTTERS

For use with hand held portable drills, bench drills, pedestal drills & magnetic base drilling machines. Suitable for cutting metals & plastics.

- 8mm depth of cut
- 1/2" Weldon Shank



Part No.	Diameter	Depth Of Cut	Shank Size
HMMC08	8mm	8mm	1/2" (12.7mm)
HMMC10	10mm	8mm	1/2" (12.7mm)
HMMC12	12mm	8mm	1/2" (12.7mm)
HMMC13	13mm	8mm	1/2" (12.7mm)
HMMC14	14mm	8mm	1/2" (12.7mm)
HMMC16	16mm	8mm	1/2" (12.7mm)
HMMC18	18mm	8mm	1/2" (12.7mm)
HMMC20	20mm	8mm	1/2" (12.7mm)
HMMC22	22mm	8mm	1/2" (12.7mm)
HMMC24	24mm	8mm	1/2" (12.7mm)
HMMC25	25mm	8mm	1/2" (12.7mm)

MINI CUTTER ADAPTOR 3/4" WELDON SHANK

Allows the use of Holemaker Mini Cutters in Holemaker Magnetic Base Drilling Machines with standard 3/4" Weldon Arbors.



Part No.	Internal Diameter	Shank
HMMCA19	1/2" Weldon	3/4" Weldon
SPMC03	Pilot Pin, 3.95 X 68mm Suit Mini Cutter In Adaptor	

MINI CUTTER ARBOR 10MM STRAIGHT SHANK

Allows the use of Holemaker Mini Cutters in standard twist drill chucks.



Part No.	Internal Diameter	Shank
HMMCA10	1/2" Weldon	10mm Straight
SPMC01	Pilot Pin, 3.95 X 43mm Suit Mini Cutter In Drill Arbor	

SHEET METAL CUTTERS INDIVIDUAL SIZES

For use with hand held portable drills, suitable for sheet metal & plastics.



Part No.	Diameter	Depth Of Cut	Thread Size
METRIC			
HSMC08	8mm	1/4" (6.34mm)	3/8-24
HSMC09	9mm	1/4" (6.34mm)	3/8-24
HSMC10	10mm	1/4" (6.34mm)	3/8-24
HSMC11	11mm	1/4" (6.34mm)	3/8-24
HSMC12	12mm	1/4" (6.34mm)	3/8-24
HSMC13	13mm	1/4" (6.34mm)	3/8-24
HSMC14	14mm	1/4" (6.34mm)	3/8-24
HSMC15	15mm	1/4" (6.34mm)	3/8-24
HSMC16	16mm	1/4" (6.34mm)	3/8-24
HSMC17	17mm	1/4" (6.34mm)	3/8-24
HSMC18	18mm	1/4" (6.34mm)	3/8-24
HSMC19	19mm	1/4" (6.34mm)	3/8-24
HSMC20	20mm	1/4" (6.34mm)	3/8-24
HSMC21	21mm	1/2" (12.7mm)	1/2-20
HSMC22	22mm	1/2" (12.7mm)	1/2-20
HSMC23	23mm	1/2" (12.7mm)	1/2-20
HSMC24	24mm	1/2" (12.7mm)	1/2-20
HSMC25	25mm	1/2" (12.7mm)	1/2-20
IMPERIAL			
HSMC-5/16	5/16"	1/4" (6.34mm)	3/8-24
HSMC-3/8	3/8"	1/4" (6.34mm)	3/8-24
HSMC-7/16	7/16"	1/4" (6.34mm)	3/8-24
HSMC-1/2	1/2"	1/4" (6.34mm)	3/8-24
HSMC-9/16	9/16"	1/4" (6.34mm)	3/8-24
HSMC-5/8	5/8"	1/4" (6.34mm)	3/8-24
HSMC-11/16	11/16"	1/4" (6.34mm)	3/8-24
HSMC-3/4	3/4"	1/4" (6.34mm)	3/8-24
HSMC-13/16	13/16"	1/2" (12.7mm)	1/2-20
HSMC-7/8	7/8"	1/2" (12.7mm)	1/2-20
HSMC-15/16	15/16"	1/2" (12.7mm)	1/2-20
HSMC-1	1"	1/2" (12.7mm)	1/2-20

SHEET METAL CUTTER SET METRIC & IMPERIAL



Part No.	Set Contents
HSMC-SET	8mm, 10mm, 12mm, 14mm, 16mm, 18mm, 20mm Arbor, Pilot Pin, Hex Key, Centre Punch, Small & Large Washers, Carry Case
HSMC-IMPSET	5/16", 3/8", 1/2", 9/16", 5/8", 11/16", 3/4" Arbor, Pilot Pin, Hex Key, Centre Punch, Small & Large Washers, Carry Case

SHEET METAL CUTTERS ARBORS & PILOT PINS

Arbors include pilot pin

Part No.	Diameter	Thread Size
H SMA0820	Arbor To Suit 8mm - 20mm, 5/16" - 3/4" Cutters	3/8-24
H SMA2125	Arbor To Suit 21mm - 25mm, 13/16" - 1" Cutters	1/2-20
H SMP0820	Pilot Pin To Suit 8mm - 20mm, 5/16" - 3/4" Cutters	-
H SMP2125	Pilot Pin To Suit 21mm - 25mm, 13/16" - 1" Cutters	-

JOBBER DRILLS - CARDED

METRIC HIGH SPEED STEEL

M2 High Speed Steel

- Premium HSS M2 material to provide long life in demanding professional applications

Split point

- Starts drilling on contact
- No "walking" or "skating" on drilling surface
- No centre punch required

118° Point Angle

- Suitable for heavy-duty drilling in metal, wood and plastic



JOBBER DRILLS - CARDED

IMPERIAL HIGH SPEED STEEL

M2 High Speed Steel

- Premium HSS M2 material to provide long life in demanding professional applications

Split point

- Starts drilling on contact
- No "walking" or "skating" on drilling surface
- No centre punch required

118° Point Angle

- Suitable for heavy-duty drilling in metal, wood and plastic



Part No.	Diameter	Flute Length	Overall Length	Qty Per Pack
UN304-010	1mm	12mm	34mm	2
UN304-015	1.5mm	18mm	40mm	2
UN304-020	2mm	24mm	49mm	2
UN304-025	2.5mm	30mm	57mm	2
UN304-030	3mm	33mm	61mm	2
UN304-035	3.5mm	39mm	70mm	1
UN304-040	4mm	43mm	75mm	1
UN304-045	4.5mm	47mm	80mm	1
UN304-050	5mm	52mm	86mm	1
UN304-055	5.5mm	57mm	93mm	1
UN304-060	6mm	57mm	93mm	1
UN304-065	6.5mm	63mm	101mm	1
UN304-070	7mm	69mm	109mm	1
UN304-075	7.5mm	69mm	109mm	1
UN304-080	8mm	75mm	117mm	1
UN304-085	8.5mm	75mm	117mm	1
UN304-090	9mm	81mm	125mm	1
UN304-095	9.5mm	81mm	125mm	1
UN304-100	10mm	87mm	133mm	1
UN304-105	10.5mm	87mm	133mm	1
UN304-110	11mm	94mm	142mm	1
UN304-115	11.5mm	94mm	142mm	1
UN304-120	12mm	101mm	151mm	1
UN304-125	12.5mm	101mm	151mm	1
UN304-130	13mm	101mm	151mm	1

Part No.	Diameter	Flute Length	Overall Length	Qty Per Pack
UN306-062	1/16"	22mm	48mm	2
UN306-078	5/64"	25mm	51mm	2
UN306-093	3/32"	32mm	57mm	2
UN306-109	7/64"	38mm	67mm	2
UN306-125	1/8"	41mm	70mm	2
UN306-140	9/64"	44mm	73mm	1
UN306-156	5/32"	51mm	79mm	1
UN306-171	11/64"	54mm	83mm	1
UN306-187	3/16"	59mm	89mm	1
UN306-203	13/64"	62mm	92mm	1
UN306-218	7/32"	64mm	95mm	1
UN306-234	15/64"	67mm	98mm	1
UN306-250	1/4"	70mm	102mm	1
UN306-265	17/64"	73mm	105mm	1
UN306-281	9/32"	75mm	108mm	1
UN306-296	19/64"	78mm	111mm	1
UN306-312	5/16"	81mm	114mm	1
UN306-328	21/64"	84mm	117mm	1
UN306-343	11/32"	87mm	121mm	1
UN306-359	23/64"	89mm	124mm	1
UN306-375	3/8"	92mm	127mm	1
UN306-390	25/64"	95mm	130mm	1
UN306-406	13/32"	98mm	133mm	1
UN306-421	27/64"	100mm	137mm	1
UN306-437	7/16"	103mm	140mm	1
UN306-453	29/64"	106mm	143mm	1
UN306-468	15/32"	110mm	146mm	1
UN306-484	31/64"	111mm	149mm	1
UN306-500	1/2"	114mm	152mm	1

JOBBER DRILLS - BULK METRIC HIGH SPEED STEEL

M2 High Speed Steel

- Premium HSS M2 material to provide long life in demanding professional applications

Split point

- Starts drilling on contact
- No "walking" or "skating" on drilling surface
- No centre punch required

118° Point Angle

- Suitable for heavy-duty drilling in metal, wood and plastic



Part No.	Diameter	Flute Length	Overall Length	Qty Per Pack
UN300-010	1mm	12mm	34mm	10
UN300-015	1.5mm	18mm	40mm	10
UN300-020	2mm	24mm	49mm	10
UN300-025	2.5mm	30mm	57mm	10
UN300-030	3mm	33mm	61mm	10
UN300-035	3.5mm	39mm	70mm	10
UN300-040	4mm	43mm	75mm	10
UN300-045	4.5mm	47mm	80mm	10
UN300-050	5mm	52mm	86mm	10
UN300-055	5.5mm	57mm	93mm	10
UN300-058	5.8mm	57mm	93mm	10
UN300-060	6mm	63mm	101mm	10
UN300-065	6.5mm	69mm	109mm	10
UN300-070	7mm	69mm	109mm	10
UN300-075	7.5mm	75mm	117mm	10
UN300-080	8mm	75mm	117mm	5
UN300-085	8.5mm	81mm	125mm	5
UN300-090	9mm	81mm	125mm	5
UN300-095	9.5mm	87mm	133mm	5
UN300-100	10mm	87mm	133mm	5
UN300-105	10.5mm	94mm	142mm	5
UN300-110	11mm	94mm	142mm	5
UN300-115	11.5mm	94mm	142mm	5
UN300-120	12mm	101mm	151mm	5
UN300-125	12.5mm	101mm	151mm	5
UN300-130	13mm	101mm	151mm	5

JOBBER DRILLS - BULK IMPERIAL HIGH SPEED STEEL

M2 High Speed Steel

- Premium HSS M2 material to provide long life in demanding professional applications

Split point

- Starts drilling on contact
- No "walking" or "skating" on drilling surface
- No centre punch required

118° Point Angle

- Suitable for heavy-duty drilling in metal, wood and plastic

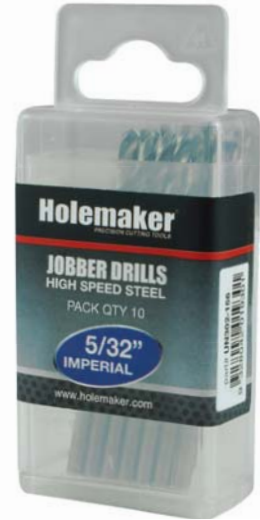

Part No.	Diameter	Flute Length	Overall Length	Qty Per Pack
UN302-062	1/16"	22mm	48mm	10
UN302-078	5/64"	25mm	51mm	10
UN302-093	3/32"	32mm	57mm	10
UN302-109	7/64"	38mm	67mm	10
UN302-125	1/8"	41mm	70mm	10
UN302-140	9/64"	44mm	73mm	10
UN302-156	5/32"	51mm	79mm	10
UN302-171	11/64"	54mm	83mm	10
UN302-187	3/16"	59mm	89mm	10
UN302-203	13/64"	62mm	92mm	10
UN302-218	7/32"	64mm	95mm	10
UN302-234	15/64"	67mm	98mm	10
UN302-250	1/4"	70mm	102mm	10
UN302-265	17/64"	73mm	105mm	10
UN302-281	9/32"	75mm	108mm	10
UN302-296	19/64"	78mm	111mm	10
UN302-312	5/16"	81mm	114mm	5
UN302-328	21/64"	84mm	117mm	5
UN302-343	11/32"	87mm	121mm	5
UN302-359	23/64"	89mm	124mm	5
UN302-375	3/8"	92mm	127mm	5
UN302-390	25/64"	95mm	130mm	5
UN302-406	13/32"	98mm	133mm	5
UN302-421	27/64"	100mm	137mm	5
UN302-437	7/16"	103mm	140mm	5
UN302-453	29/64"	106mm	143mm	5
UN302-468	15/32"	110mm	146mm	5
UN302-484	31/64"	111mm	149mm	5
UN302-500	1/2"	114mm	152mm	5

JOBBER DRILL SETS METRIC HIGH SPEED STEEL



PART NO. UN308-110 | 19 PIECE METRIC SET 1.0mm - 10.0mm

Part No.	Diameter	Part No.	Diameter
UN304-010	1mm	UN304-060	6mm
UN304-015	1.5mm	UN304-065	6.5mm
UN304-020	2mm	UN304-070	7mm
UN304-025	2.5mm	UN304-075	7.5mm
UN304-030	3mm	UN304-080	8mm
UN304-035	3.5mm	UN304-085	8.5mm
UN304-040	4mm	UN304-090	9mm
UN304-045	4.5mm	UN304-095	9.5mm
UN304-050	5mm	UN304-100	10mm
UN304-055	5.5mm		

JOBBER DRILL SETS IMPERIAL HIGH SPEED STEEL



PART NO. UN308-340 | 21 PIECE IMPERIAL SET 1/16" - 3/8"

Part No.	Diameter	Part No.	Diameter
UN306-062	1/16"	UN306-234	15/64"
UN306-078	5/64"	UN306-250	1/4"
UN306-093	3/32"	UN306-265	17/64"
UN306-109	7/64"	UN306-281	9/32"
UN306-125	1/8"	UN306-296	19/64"
UN306-140	9/64"	UN306-312	5/16"
UN306-156	5/32"	UN306-328	21/64"
UN306-171	11/64"	UN306-343	11/32"
UN306-187	3/16"	UN306-359	23/64"
UN306-203	13/64"	UN306-375	3/8"
UN306-218	7/32"		



PART NO. UN308-120 | 25 PIECE METRIC SET 1.0mm - 13.0mm

Part No.	Diameter	Part No.	Diameter
UN304-010	1mm	UN304-075	7.5mm
UN304-015	1.5mm	UN304-080	8mm
UN304-020	2mm	UN304-085	8.5mm
UN304-025	2.5mm	UN304-090	9mm
UN304-030	3mm	UN304-095	9.5mm
UN304-035	3.5mm	UN304-100	10mm
UN304-040	4mm	UN304-105	10.5mm
UN304-045	4.5mm	UN304-110	11mm
UN304-050	5mm	UN304-115	11.5mm
UN304-055	5.5mm	UN304-120	12mm
UN304-060	6mm	UN304-125	12.5mm
UN304-065	6.5mm	UN304-130	13mm
UN304-070	7mm		



PART NO. UN308-360 | 29 PIECE IMPERIAL SET 1/16" - 1/2"

Part No.	Diameter	Part No.	Diameter
UN306-062	1/16"	UN306-296	19/64"
UN306-078	5/64"	UN306-312	5/16"
UN306-093	3/32"	UN306-328	21/64"
UN306-109	7/64"	UN306-343	11/32"
UN306-125	1/8"	UN306-359	23/64"
UN306-140	9/64"	UN306-375	3/8"
UN306-156	5/32"	UN306-390	5/64"
UN306-171	11/64"	UN306-406	13/32"
UN306-187	3/16"	UN306-421	27/64"
UN306-203	13/64"	UN306-437	7/16"
UN306-218	7/32"	UN306-453	29/64"
UN306-234	15/64"	UN306-468	15/32"
UN306-250	1/4"	UN306-484	31/64"
UN306-265	17/64"	UN306-500	1/2"
UN306-281	9/32"		

JOBBER DRILL SETS

METRIC HIGH SPEED STEEL

M2 High Speed Steel

- Premium HSS M2 material to provide long life in demanding professional applications

Split point

- Starts drilling on contact
- No "walking" or "skating" on drilling surface
- No centre punch required

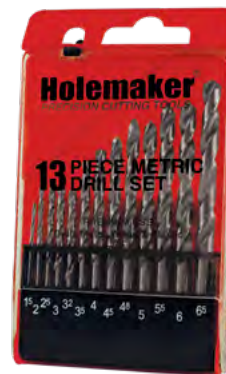

PART NO. UN308-008 | 13PIECE METRIC SET 1.5mm - 6.5mm

Part No.	Diameter	Part No.	Diameter
UN304-015	1.5mm	UN304-050	4.5mm
UN304-020	2mm	UN304-055	4.8mm
UN304-025	2.5mm	UN304-060	5mm
UN304-030	3mm	UN304-065	5.5mm
UN304-035	3.2mm	UN304-065	6mm
UN304-040	3.5mm	UN304-070	6.5mm
UN304-045	4mm		



PART NO. UN308-020 | 25 PIECE METRIC SET 1.0mm - 13.0mm

Part No.	Diameter	Part No.	Diameter
UN304-010	1mm	UN304-075	7.5mm
UN304-015	1.5mm	UN304-080	8mm
UN304-020	2mm	UN304-085	8.5mm
UN304-025	2.5mm	UN304-090	9mm
UN304-030	3mm	UN304-095	9.5mm
UN304-035	3.5mm	UN304-100	10mm
UN304-040	4mm	UN304-105	10.5mm
UN304-045	4.5mm	UN304-110	11mm
UN304-050	5mm	UN304-115	11.5mm
UN304-055	5.5mm	UN304-120	12mm
UN304-060	6mm	UN304-125	12.5mm
UN304-065	6.5mm	UN304-130	13mm
UN304-070	7mm		



PART NO. UN308-010 | 19 PIECE METRIC SET 1.0mm - 10.0mm

Part No.	Diameter	Part No.	Diameter
UN304-010	1mm	UN304-060	6mm
UN304-015	1.5mm	UN304-065	6.5mm
UN304-020	2mm	UN304-070	7mm
UN304-025	2.5mm	UN304-075	7.5mm
UN304-030	3mm	UN304-080	8mm
UN304-035	3.5mm	UN304-085	8.5mm
UN304-040	4mm	UN304-090	9mm
UN304-045	4.5mm	UN304-095	9.5mm
UN304-050	5mm	UN304-100	10mm
UN304-055	5.5mm		

REDUCED SHANK DRILLS METRIC HIGH SPEED STEEL

12.7mm shank diameter

M2 High Speed Steel

- Premium HSS M2 material to provide long life in demanding professional applications

118° Point Angle

- Suitable for heavy-duty drilling in metal, wood and plastic



Part No.	Diameter	Flute Length	Overall Length	Qty Per Pack
UN310-135	13.5mm	76mm	152mm	1
UN310-140	14mm	76mm	152mm	1
UN310-150	15mm	76mm	152mm	1
UN310-160	16mm	76mm	152mm	1
UN310-170	17mm	76mm	152mm	1
UN310-180	18mm	76mm	152mm	1
UN310-190	19mm	76mm	152mm	1
UN310-200	20mm	76mm	152mm	1
UN310-210	21mm	76mm	152mm	1
UN310-220	22mm	76mm	152mm	1
UN310-230	23mm	76mm	152mm	1
UN310-240	24mm	76mm	152mm	1
UN310-250	25mm	76mm	152mm	1
UN310-260	26mm	76mm	152mm	1
UN310-270	27mm	76mm	152mm	1
UN310-280	28mm	76mm	152mm	1
UN310-290	29mm	76mm	152mm	1
UN310-300	30mm	76mm	152mm	1
UN310-310	31mm	76mm	152mm	1
UN310-320	32mm	76mm	152mm	1

BI-METAL HOLESAWS

PREMIUM QUALITY BI-METAL M42 COBALT HIGH SPEED STEEL

Suitable for drilling a wide range of materials including steel, aluminium, brass, cast iron, plastics & wood. The M42 (8% Cobalt) high speed steel teeth offer optimal cutting life & performance.

VARIABLE PITCH 4 / 6 TEETH PER INCH

For reduced vibration delivering increased life, performance & accuracy.



Part No.	Diameter Metric	Diameter Imperial	Thread
UN100-014	14mm	9/16"	1/2"
UN100-016	16mm	5/8"	1/2"
UN100-017	17mm	11/16"	1/2"
UN100-019	19mm	3/4"	1/2"
UN100-020	20mm	-	1/2"
UN100-021	21mm	13/16"	1/2"
UN100-022	22mm	7/8"	1/2"
UN100-024	24mm	15/16"	1/2"
UN100-025	25mm	1"	1/2"
UN100-027	27mm	1-1/16"	1/2"
UN100-029	29mm	1-1/8"	1/2"
UN100-030	30mm	1-3/16"	1/2"
UN100-032	32mm	1-1/4"	5/8"
UN100-033	33mm	1-5/16"	5/8"
UN100-035	35mm	1-3/8"	5/8"
UN100-037	37mm	1-7/16"	5/8"
UN100-038	38mm	1-1/2"	5/8"
UN100-040	40mm	1-9/16"	5/8"
UN100-041	41mm	1-5/8"	5/8"
UN100-043	43mm	1-11/16"	5/8"
UN100-044	44mm	1-3/4"	5/8"
UN100-045	45mm	-	5/8"
UN100-046	46mm	1-13/16"	5/8"
UN100-048	48mm	1-7/8"	5/8"
UN100-050	50mm	-	5/8"
UN100-051	51mm	2"	5/8"
UN100-052	52mm	2-1/16"	5/8"
UN100-054	54mm	2-1/8"	5/8"
UN100-055	55mm	-	5/8"
UN100-057	57mm	2-1/4"	5/8"
UN100-059	59mm	2-5/16"	5/8"
UN100-060	60mm	2-3/8"	5/8"
UN100-064	64mm	2-1/2"	5/8"
UN100-065	65mm	2-9/16"	5/8"

Part No.	Diameter Metric	Diameter Imperial	Thread
UN100-067	67mm	2-5/8"	5/8"
UN100-068	68mm	-	5/8"
UN100-070	70mm	2-3/4"	5/8"
UN100-073	73mm	2-7/8"	5/8"
UN100-075	75mm	-	5/8"
UN100-076	76mm	3"	5/8"
UN100-079	79mm	3-1/8"	5/8"
UN100-083	83mm	3-1/4"	5/8"
UN100-086	86mm	3-3/8"	5/8"
UN100-089	89mm	3-1/2"	5/8"
UN100-092	92mm	3-5/8"	5/8"
UN100-095	95mm	3-3/4"	5/8"
UN100-098	98mm	3-7/8"	5/8"
UN100-100	100mm	-	5/8"
UN100-102	102mm	4"	5/8"
UN100-105	105mm	4-1/8"	5/8"
UN100-108	108mm	4-1/4"	5/8"
UN100-111	111mm	4-3/8"	5/8"
UN100-114	114mm	4-1/2"	5/8"
UN100-121	121mm	4-3/4"	5/8"
UN100-127	127mm	5"	5/8"
UN100-130	130mm	-	5/8"
UN100-140	140mm	5-1/2"	5/8"
UN100-146	146mm	5-3/4"	5/8"
UN100-150	150mm	-	5/8"
UN100-152	152mm	6"	5/8"

ARBOR 1/4" ROUND SHANK

- Suits 14 to 30mm holesaws



Part No.	Description
UN102-120	Arbor 1/4" Round Shank Suit 14 To 30mm Holesaws

ARBOR 11/32" QUICK CHANGE HEX SHANK

- Suits 14 to 30mm holesaws



Part No.	Description
UN102-125	Arbor 11/32" Quick Change Hex Shank Suit 14 To 30mm Holesaws

ARBOR 11/32" HEX SHANK

- Suits 32 to 152mm holesaws



Part No.	Description
UN102-130	Arbor 11/32" Hex Shank Suit 32 To 152mm Holesaws

ARBOR 11/32" QUICK CHANGE HEX SHANK

- Suits 32 to 152mm holesaws



Part No.	Description
UN102-135	Arbor 11/32" Quick Change Hex Shank Suit 32 To 152mm Holesaws

ARBOR 7/16" HEX SHANK

- Suits 32 to 152mm holesaws



Part No.	Description
UN102-140	Arbor 7/16" Hex Shank Suit 32 To 152mm Holesaws



EXTENSION BAR

- 300mm length



Part No.	Description
UN102-100	Extension Bar 300mm Length

ARBOR PILOT DRILLS



Part No.	Description
UN102-105	Arbor Pilot Drill 1/4" x 3" (6.34 x 75mm)
UN102-110	Arbor Pilot Drill 1/4" x 3-1/4" (6.34 x 83mm)
UN102-115	Arbor Pilot Drill 1/4" x 4-1/8" (6.34 x 105mm)

THREAD ADAPTOR

- Converts 1/2" to 5/8"



Part No.	Description
UN102-145	Thread Adaptor 1/2" To 5/8"

BI-METAL HOLESAW SETS

PREMIUM QUALITY BI-METAL M42 COBALT HIGH SPEED STEEL

Suitable for drilling a wide range of materials including steel, aluminium, brass, cast iron, plastics & wood. The M42 (8% Cobalt) high speed steel teeth offer optimal cutting life & performance.

VARIABLE PITCH 4 / 6 TEETH PER INCH

For reduced vibration delivering increased life, performance & accuracy.



GENERAL ENGINEERING SET

PART NO. UN108-100 SET CONTENTS			
Quantity	Part No.	Diameter Metric	Diameter Imperial
1	UN100-016	16mm	5/8"
1	UN100-019	19mm	3/4"
1	UN100-022	22mm	7/8"
1	UN100-025	25mm	1"
1	UN100-032	32mm	1-1/4"
1	UN100-035	35mm	1-3/8"
1	UN100-038	38mm	1-1/2"
1	UN100-044	44mm	1-3/4"
1	UN100-051	51mm	2"
1	UN100-057	57mm	2-1/4"
1	UN100-064	64mm	2-1/2"
1	UN100-076	76mm	3"
1	UN102-125	11/32" Arbor	
1	UN102-140	7/16" Arbor	
1	UN102-145	Arbor Thread Adaptor	
1	UN102-100	12" Extension Bar	



HANDYMAN SET

PART NO. UN108-110 SET CONTENTS			
Quantity	Part No.	Diameter Metric	Diameter Imperial
1	UN100-022	22mm	7/8"
1	UN100-025	25mm	1"
1	UN100-029	29mm	1-1/8"
1	UN100-032	32mm	1-1/4"
1	UN100-038	38mm	1-1/2"
1	UN102-125	11/32" Arbor	
1	UN102-145	Arbor Thread Adaptor	



LOCKSMITH SET

PART NO. UN108-130 SET CONTENTS			
Quantity	Part No.	Diameter Metric	Diameter Imperial
1	UN100-022	22mm	7/8"
1	UN100-025	25mm	1"
1	UN100-032	32mm	1-1/4"
1	UN100-038	38mm	1-1/2"
1	UN100-044	44mm	1-3/4"
1	UN100-054	54mm	2-1/8"
1	UN102-125	11/32" Arbor	
1	UN102-140	7/16" Arbor	
1	UN102-145	Arbor Thread Adaptor	



PLUMBERS - COPPER SET

PART NO. UN108-140 SET CONTENTS			
Quantity	Part No.	Diameter Metric	Diameter Imperial
1	UN100-016	16mm	5/8"
1	UN100-022	22mm	7/8"
1	UN100-027	27mm	1-1/16"
1	UN100-043	43mm	1-11/16"
1	UN100-054	54mm	2-1/8"
1	UN100-067	67mm	2-5/8"
1	UN102-125	11/32" Arbor	
1	UN102-140	7/16" Arbor	
1	UN102-145	Arbor Thread Adaptor	



ELECTRICIANS SET

PART NO. UN108-120 SET CONTENTS			
Quantity	Part No.	Diameter Metric	Diameter Imperial
1	UN100-016	16mm	5/8"
1	UN100-020	20mm	-
1	UN100-025	25mm	1"
1	UN100-032	32mm	1-1/4"
1	UN100-040	40mm	1-9/16"
1	UN100-051	51mm	2"
1	UN100-125	11/32" Arbor	
1	UN102-140	7/16" Arbor	
1	UN102-145	Arbor Thread Adaptor	



PLUMBERS - PVC SET

PART NO. UN108-150 SET CONTENTS			
Quantity	Part No.	Diameter Metric	Diameter Imperial
1	UN100-044	44mm	1-3/4"
1	UN100-051	51mm	2"
1	UN100-063	63mm	-
1	UN100-079	79mm	3-1/8"
1	UN100-092	92mm	3-5/8"
1	UN100-121	121mm	4-3/4"
1	UN102-140	7/16" Arbor	

T.C.T. HOLESAWS

Tungsten Carbide Tipped Holesaws. Suitable for drilling steel, stainless steel, aluminium, FRP, PVC, plastics & fibreglass. Ejector spring fitted as standard. Not for impact use.

The tungsten carbide tip maintains excellent durability due to the ideal blade angles. The cutting angle design uses the latest metal cutting technology. The escape angle discharges shavings quickly for smooth snag free cutting.

NON-UNIFORM DISTANCES BETWEEN TEETH

Vibration is reduced by the non-uniform and varied distances between the teeth

ONE PIECE BODY STRUCTURE

With a one piece structure, there is no play or flexing between the shank and cutting edge, resulting in sharp, crisp, smooth cutting

SAFE STOPPER COLLAR

Getting the holesaw stuck in the back of the cut material is prevented for safer, faster drilling

CORDLESS TOOLS

The 3.2mm depth of cut Holemaker holesaws are specially designed for use with cordless tools.

- Holemaker holesaws - 3.2mm depth include a spring
- Holemaker holesaws - 4.5mm depth include a spring
- Holemaker holesaws - 25mm depth include a spring in sizes 20mm and larger
- Holemaker holesaws - 35mm depth do not include a spring
- Holemaker holesaws - 50mm depth do not include a spring

T.C.T. HOLESAWS - 3.2MM DEPTH OF CUT TO SUIT CORDLESS DRILLS



Part No.	Diameter	Depth Of Cut	Hex Shank Size
MCJ16	16mm	3.2mm	6.34mm (1/4")
MCJ18	18mm	3.2mm	6.34mm (1/4")
MCJ19	19mm	3.2mm	6.34mm (1/4")
MCJ20	20mm	3.2mm	6.34mm (1/4")
MCJ22	22mm	3.2mm	6.34mm (1/4")
MCJ23	23mm	3.2mm	6.34mm (1/4")
MCJ24	24mm	3.2mm	6.34mm (1/4")
MCJ25	25mm	3.2mm	6.34mm (1/4")
MCJ26	26mm	3.2mm	6.34mm (1/4")
MCJ28	28mm	3.2mm	6.34mm (1/4")
MCJ30	30mm	3.2mm	6.34mm (1/4")
MCJ32	32mm	3.2mm	6.34mm (1/4")
MCJ33	33mm	3.2mm	6.34mm (1/4")
MCJ35	35mm	3.2mm	6.34mm (1/4")

Holemaker holesaws - 3.2mm depth include a spring

T.C.T. HOLESAW 3.2MM DEPTH PARTS



Part No.	Description
MCJ-DRILL	Pilot Drill To Suit Holemaker 3.2mm Depth T.C.T. Holesaws
MCJ-SPRING	Ejection Spring To Suit Holemaker 3.2mm Depth T.C.T. Holesaws

T.C.T. HOLESAWS - 4.5MM DEPTH OF CUT



Part No.	Diameter	Depth Of Cut	Shank Diameter
MCS14	14mm	4.5mm	10mm
MCS15	15mm	4.5mm	10mm
MCS16	16mm	4.5mm	10mm
MCS17	17mm	4.5mm	10mm
MCS18	18mm	4.5mm	10mm
MCS19	19mm	4.5mm	10mm
MCS20	20mm	4.5mm	10mm
MCS21	21mm	4.5mm	10mm
MCS22	22mm	4.5mm	10mm
MCS23	23mm	4.5mm	10mm
MCS24	24mm	4.5mm	10mm
MCS25	25mm	4.5mm	10mm
MCS26	26mm	4.5mm	10mm
MCS27	27mm	4.5mm	10mm
MCS28	28mm	4.5mm	10mm
MCS29	29mm	4.5mm	10mm
MCS30	30mm	4.5mm	10mm
MCS31	31mm	4.5mm	10mm
MCS32	32mm	4.5mm	10mm
MCS33	33mm	4.5mm	10mm
MCS34	34mm	4.5mm	10mm
MCS35	35mm	4.5mm	10mm / 13mm
MCS36	36mm	4.5mm	10mm / 13mm
MCS37	37mm	4.5mm	10mm / 13mm
MCS38	38mm	4.5mm	10mm / 13mm
MCS39	39mm	4.5mm	10mm / 13mm
MCS40	40mm	4.5mm	10mm / 13mm
MCS41	41mm	4.5mm	10mm / 13mm
MCS42	42mm	4.5mm	10mm / 13mm
MCS43	43mm	4.5mm	10mm / 13mm
MCS44	44mm	4.5mm	10mm / 13mm
MCS45	45mm	4.5mm	10mm / 13mm
MCS46	46mm	4.5mm	10mm / 13mm
MCS47	47mm	4.5mm	10mm / 13mm
MCS48	48mm	4.5mm	10mm / 13mm
MCS49	49mm	4.5mm	10mm / 13mm
MCS50	50mm	4.5mm	10mm / 13mm
MCS51	51mm	4.5mm	10mm / 13mm
MCS52	52mm	4.5mm	10mm / 13mm
MCS53	53mm	4.5mm	10mm / 13mm
MCS54	54mm	4.5mm	10mm / 13mm
MCS55	55mm	4.5mm	10mm / 13mm
MCS56	56mm	4.5mm	10mm / 13mm
MCS57	57mm	4.5mm	10mm / 13mm
MCS58	58mm	4.5mm	10mm / 13mm
MCS59	59mm	4.5mm	10mm / 13mm
MCS60	60mm	4.5mm	10mm / 13mm

Holemaker holesaws - 4.5mm depth include a spring

T.C.T. HOLESAWS - 4.5MM DEPTH OF CUT



Part No.	Diameter	Depth Of Cut	Shank Diameter
MCS61	61mm	4.5mm	10mm / 13mm
MCS62	62mm	4.5mm	10mm / 13mm
MCS63	63mm	4.5mm	10mm / 13mm
MCS64	64mm	4.5mm	10mm / 13mm
MCS65	65mm	4.5mm	10mm / 13mm
MCS67	67mm	4.5mm	10mm / 13mm
MCS70	70mm	4.5mm	10mm / 13mm
MCS75	75mm	4.5mm	10mm / 13mm
MCS76	76mm	4.5mm	10mm / 13mm
MCS78	78mm	4.5mm	10mm / 13mm
MCS80	80mm	4.5mm	10mm / 13mm
MCS82	82mm	4.5mm	10mm / 13mm
MCS85	85mm	4.5mm	10mm / 13mm
MCS88	88mm	4.5mm	10mm / 13mm
MCS90	90mm	4.5mm	10mm / 13mm
MCS92	92mm	4.5mm	10mm / 13mm
MCS95	95mm	4.5mm	10mm / 13mm
MCS98	98mm	4.5mm	10mm / 13mm
MCS100	100mm	4.5mm	10mm / 13mm
MCS102	102mm	4.5mm	10mm / 13mm
MCS105	105mm	4.5mm	10mm / 13mm
MCS108	108mm	4.5mm	10mm / 13mm
MCS110	110mm	4.5mm	10mm / 13mm
MCS112	112mm	4.5mm	10mm / 13mm
MCS115	115mm	4.5mm	10mm / 13mm
MCS118	118mm	4.5mm	10mm / 13mm
MCS120	120mm	4.5mm	10mm / 13mm
MCS122	122mm	4.5mm	10mm / 13mm
MCS125	125mm	4.5mm	10mm / 13mm
MCS127	127mm	4.5mm	10mm / 13mm
MCS130	130mm	4.5mm	10mm / 13mm
MCS133	133mm	4.5mm	10mm / 13mm
MCS135	135mm	4.5mm	10mm / 13mm
MCS137	137mm	4.5mm	10mm / 13mm
MCS140	140mm	4.5mm	10mm / 13mm
MCS143	143mm	4.5mm	10mm / 13mm
MCS145	145mm	4.5mm	10mm / 13mm
MCS147	147mm	4.5mm	10mm / 13mm
MCS150	150mm	4.5mm	10mm / 13mm

Holemaker holesaws - 4.5mm depth include a spring

T.C.T. HOLESAW 4.5MM DEPTH PARTS



Part No.	Description
MCS-DRILL	Pilot Drill To Suit Holemaker 4.5mm Depth T.C.T. Holesaws
MCS-SPRING	Ejection Spring To Suit Holemaker 3.2mm Depth T.C.T. Holesaws

T.C.T. HOLESAWS

WIDE RANGE OF APPLICATIONS

Suitable for drilling steel plate, stainless steel, A.C. sheeting, aluminium, FRP, PVC, fibreglass & concrete coated pipes

TRIPLE-CUT 3 EDGE CUTTING SYSTEM

There are two sets of three different edged cutting teeth. One tooth slanted outward, one inward and one that peaks in the centre. This arrangement balances the cutting effort for smooth boring, better control and less chance of excess drag.

ONE PIECE BODY STRUCTURE

With a one piece structure, there is no play or flexing between the shank and cutting edge, resulting in sharp, crisp, smooth cutting

SAFE STOPPER COLLAR

Getting the holesaw stuck in the back of the cut material is prevented for safer, faster drilling

T.C.T. HOLESAWS - 25MM DEPTH OF CUT



Part No.	Diameter	Depth Of Cut	Shank Diameter
MCTR14	14mm	25mm	10mm
MCTR15	15mm	25mm	10mm
MCTR16	16mm	25mm	10mm
MCTR17	17mm	25mm	10mm
MCTR18	18mm	25mm	10mm
MCTR19	19mm	25mm	10mm
MCTR20	20mm	25mm	10mm
MCTR21	21mm	25mm	10mm
MCTR22	22mm	25mm	10mm
MCTR23	23mm	25mm	10mm
MCTR24	24mm	25mm	10mm
MCTR25	25mm	25mm	10mm
MCTR26	26mm	25mm	10mm
MCTR27	27mm	25mm	10mm
MCTR28	28mm	25mm	10mm
MCTR29	29mm	25mm	10mm
MCTR30	30mm	25mm	10mm
MCTR31	31mm	25mm	10mm / 13mm
MCTR32	32mm	25mm	10mm / 13mm
MCTR33	33mm	25mm	10mm / 13mm
MCTR34	34mm	25mm	10mm / 13mm
MCTR35	35mm	25mm	10mm / 13mm
MCTR36	36mm	25mm	10mm / 13mm
MCTR37	37mm	25mm	10mm / 13mm
MCTR38	38mm	25mm	10mm / 13mm
MCTR39	39mm	25mm	10mm / 13mm
MCTR40	40mm	25mm	10mm / 13mm
MCTR41	41mm	25mm	10mm / 13mm
MCTR42	42mm	25mm	10mm / 13mm
MCTR43	43mm	25mm	10mm / 13mm
MCTR44	44mm	25mm	10mm / 13mm
MCTR45	45mm	25mm	10mm / 13mm
MCTR46	46mm	25mm	10mm / 13mm
MCTR47	47mm	25mm	10mm / 13mm
MCTR48	48mm	25mm	10mm / 13mm
MCTR49	49mm	25mm	10mm / 13mm
MCTR50	50mm	25mm	10mm / 13mm
MCTR51	51mm	25mm	10mm / 13mm

Holemaker holesaws - 25mm depth include a spring in sizes 20mm and larger

T.C.T. HOLESAWS - 25MM DEPTH OF CUT



Part No.	Diameter	Depth Of Cut	Shank Diameter
MCTR52	52mm	25mm	10mm / 13mm
MCTR53	53mm	25mm	10mm / 13mm
MCTR54	54mm	25mm	10mm / 13mm
MCTR55	55mm	25mm	10mm / 13mm
MCTR56	56mm	25mm	10mm / 13mm
MCTR57	57mm	25mm	10mm / 13mm
MCTR58	58mm	25mm	10mm / 13mm
MCTR59	59mm	25mm	10mm / 13mm
MCTR60	60mm	25mm	10mm / 13mm
MCTR61	61mm	25mm	10mm / 13mm
MCTR62	62mm	25mm	10mm / 13mm
MCTR63	63mm	25mm	10mm / 13mm
MCTR64	64mm	25mm	10mm / 13mm
MCTR65	65mm	25mm	10mm / 13mm
MCTR68	68mm	25mm	10mm / 13mm
MCTR70	70mm	25mm	10mm / 13mm
MCTR75	75mm	25mm	10mm / 13mm
MCTR77	77mm	25mm	10mm / 13mm
MCTR80	80mm	25mm	13mm
MCTR83	83mm	25mm	13mm
MCTR85	85mm	25mm	13mm
MCTR87	87mm	25mm	13mm
MCTR90	90mm	25mm	13mm
MCTR93	93mm	25mm	13mm
MCTR95	95mm	25mm	13mm
MCTR97	97mm	25mm	13mm
MCTR100	100mm	25mm	13mm
MCTR103	103mm	25mm	13mm
MCTR105	105mm	25mm	13mm
MCTR107	107mm	25mm	13mm
MCTR110	110mm	25mm	13mm
MCTR113	113mm	25mm	13mm
MCTR115	115mm	25mm	13mm
MCTR117	117mm	25mm	13mm
MCTR120	120mm	25mm	13mm
MCTR1-1/8	1-1/8"	25mm	10mm

Holemaker holesaws - 25mm depth include a spring in sizes 20mm and larger

T.C.T. HOLESAWS - 35MM DEPTH OF CUT



T.C.T. HOLESAWS - 35MM DEPTH OF CUT



Part No.	Diameter	Depth Of Cut	Shank Diameter
MCTN20	20mm	35mm	10mm
MCTN21	21mm	35mm	10mm
MCTN22	22mm	35mm	10mm
MCTN23	23mm	35mm	10mm
MCTN24	24mm	35mm	10mm
MCTN25	25mm	35mm	10mm
MCTN26	26mm	35mm	10mm
MCTN27	27mm	35mm	10mm
MCTN28	28mm	35mm	10mm
MCTN29	29mm	35mm	10mm
MCTN30	30mm	35mm	10mm
MCTN31	31mm	35mm	10mm
MCTN32	32mm	35mm	10mm
MCTN33	33mm	35mm	10mm
MCTN34	34mm	35mm	10mm / 13mm
MCTN35	35mm	35mm	10mm / 13mm
MCTN36	36mm	35mm	10mm / 13mm
MCTN37	37mm	35mm	10mm / 13mm
MCTN38	38mm	35mm	10mm / 13mm
MCTN39	39mm	35mm	10mm / 13mm
MCTN40	40mm	35mm	10mm / 13mm
MCTN41	41mm	35mm	10mm / 13mm
MCTN42	42mm	35mm	10mm / 13mm
MCTN43	43mm	35mm	10mm / 13mm
MCTN44	44mm	35mm	10mm / 13mm
MCTN45	45mm	35mm	10mm / 13mm
MCTN46	46mm	35mm	10mm / 13mm

Holemaker hole saws - 35mm depth do not include a spring

Part No.	Diameter	Depth Of Cut	Shank Diameter
MCTN47	47mm	35mm	10mm / 13mm
MCTN48	48mm	35mm	10mm / 13mm
MCTN49	49mm	35mm	10mm / 13mm
MCTN50	50mm	35mm	10mm / 13mm
MCTN51	51mm	35mm	10mm / 13mm
MCTN52	52mm	35mm	10mm / 13mm
MCTN53	53mm	35mm	10mm / 13mm
MCTN54	54mm	35mm	10mm / 13mm
MCTN55	55mm	35mm	10mm / 13mm
MCTN56	56mm	35mm	10mm / 13mm
MCTN57	57mm	35mm	10mm / 13mm
MCTN58	58mm	35mm	10mm / 13mm
MCTN59	59mm	35mm	10mm / 13mm
MCTN60	60mm	35mm	10mm / 13mm
MCTN61	61mm	35mm	10mm / 13mm
MCTN62	62mm	35mm	10mm / 13mm
MCTN63	63mm	35mm	10mm / 13mm
MCTN64	64mm	35mm	10mm / 13mm
MCTN65	65mm	35mm	10mm / 13mm
MCTN70	70mm	35mm	10mm / 13mm
MCTN75	75mm	35mm	10mm / 13mm
MCTN80	80mm	35mm	13mm
MCTN85	85mm	35mm	13mm
MCTN90	90mm	35mm	13mm
MCTN95	95mm	35mm	13mm
MCTN100	100mm	35mm	13mm
MCTN110	110mm	35mm	13mm

Holemaker hole saws - 35mm depth do not include a spring

HOLEMAKER CONSUMABLES



Part No.	Description
MCTR-DRILL	Pilot Drill To Suit T.C.T. Holesaws 25mm Depth
MCTR-SPRING	Ejection Spring To Suit T.C.T. Holesaws 25mm Depth
MCTR-SCREW	Grub Screw To Suit T.C.T. Holesaws 25mm Depth
MCTN-DRILL6	Pilot Drill To Suit T.C.T. Holesaws 35mm Depth 20 - 80mm Diameter holesaws (6mm pilot drill)
MCTN-DRILL8	Pilot Drill To Suit T.C.T. Holesaws 35mm Depth 85 - 110mm Diameter Holesaws (8mm pilot drill)

T.C.T. HOLESAWS - 50MM DEPTH OF CUT



Part No.	Diameter	Depth Of Cut	Shank Diameter
MX020	20mm	50mm	10mm
MX022	22mm	50mm	10mm
MX024	24mm	50mm	10mm
MX025	25mm	50mm	10mm
MX026	26mm	50mm	10mm
MX028	28mm	50mm	10mm
MX029	29mm	50mm	10mm
MX030	30mm	50mm	10mm
MX032	32mm	50mm	10mm
MX035	35mm	50mm	13mm
MX036	36mm	50mm	13mm
MX038	38mm	50mm	13mm
MX040	40mm	50mm	13mm
MX044	44mm	50mm	13mm
MX045	45mm	50mm	13mm
MX048	48mm	50mm	13mm
MX050	50mm	50mm	13mm
MX051	51mm	50mm	13mm
MX052	52mm	50mm	13mm
MX054	54mm	50mm	13mm
MX055	55mm	50mm	13mm
MX060	60mm	50mm	13mm

Holemaker hole saws - 50mm depth do not include a spring

HOLEMAKER MX PILOT DRILL



Part No.	Description
MX-DRILL	Pilot Drill To Suit T.C.T. Holesaws 50mm Depth

4.5MM DEPTH T.C.T HOLESAW SETS



PART NO. MCS-SET1 SET CONTENTS			
Quantity	Part No.	Diameter	Depth Of Cut
1	MCS16	16mm	4.5mm
1	MCS20	20mm	4.5mm
1	MCS22	22mm	4.5mm
1	MCS25	25mm	4.5mm
1	MCS32	32mm	4.5mm
1	MCS40	40mm	4.5mm

PART NO. MCS-SET2 SET CONTENTS			
Quantity	Part No.	Diameter	Depth Of Cut
1	MCS16	16mm	4.5mm
1	MCS20	20mm	4.5mm
1	MCS22	22mm	4.5mm
1	MCS25	25mm	4.5mm
1	MCS32	32mm	4.5mm
1	MCS40	40mm	4.5mm
1	MCS50	50mm	4.5mm

25MM DEPTH T.C.T HOLESAW SETS



35MM DEPTH T.C.T HOLESAW SETS



PART NO. MCTR-SET1 SET CONTENTS			
Quantity	Part No.	Diameter	Depth Of Cut
1	MCTR16	16mm	25mm
1	MCTR20	20mm	25mm
1	MCTR22	22mm	25mm
1	MCTR25	25mm	25mm
1	MCTR32	32mm	25mm
1	MCTR40	40mm	25mm

PART NO. MCTN-SET1 SET CONTENTS			
Quantity	Part No.	Diameter	Depth Of Cut
1	MCTN20	20mm	35mm
1	MCTN22	22mm	35mm
1	MCTN25	25mm	35mm
1	MCTN32	32mm	35mm
1	MCTN40	40mm	35mm

PART NO. MCTR-SET2 SET CONTENTS			
Quantity	Part No.	Diameter	Depth Of Cut
1	MCTR16	16mm	25mm
1	MCTR20	20mm	25mm
1	MCTR25	25mm	25mm
1	MCTR32	32mm	25mm
1	MCTR40	40mm	25mm
1	MCTR50	50mm	25mm

PART NO. MCTN-SET2 SET CONTENTS			
Quantity	Part No.	Diameter	Depth Of Cut
1	MCTN20	20mm	35mm
1	MCTN22	22mm	35mm
1	MCTN25	25mm	35mm
1	MCTN32	32mm	35mm
1	MCTN40	40mm	35mm
1	MCTN50	50mm	35mm

CUSTOM MADE SETS AVAILABLE ON REQUEST

STEP DRILLS

SPIRAL FLUTE STEP DRILLS

The Titanium Nitride coating significantly increases the tool life by providing the following benefits:

- Increased surface hardness to 85HRC
- Ceramic surface, reducing friction by up to 30%
- Especially resistant to cold welding
- Suitable for cutting a wide range of materials



Part No.	Sizes Included	Step Length	Over All Length	Shank Diameter
SD4-20MM	4, 6, 8, 10, 12, 14, 16, 18, 20mm	3.0mm	74.5mm	8mm
SD5-25MM	5, 7, 9, 11, 13, 15, 17, 19, 21, 23, 25mm	3.0mm	83.0mm	10mm
SD6-30MM	6, 8, 10, 12, 14, 16, 18, 20, 22, 24, 26, 28, 30mm	3.0mm	98.0mm	12mm
SD7-40.5MM	7, 10.5, 12.5, 14.5, 16.5, 18.5, 20.5, 23.5, 25.5, 30.5, 32.5, 38.5, 40.5mm	3.0mm	115mm	12mm

SPIRAL FLUTE STEP DRILLS LONG STEP



Part No.	Sizes Included	Step Length	Over All Length	Shank Diameter
SDL4-12MM	4, 5, 6, 7, 8, 9, 10, 11, 12mm	5.5mm	63.6mm	8mm
SDL6-38MM	6, 9, 13, 16, 19, 21, 23, 26, 29, 32, 35, 38mm	5.5mm	101mm	12mm

SPIRAL FLUTE STEP DRILLS EXTRA LONG STEP



Part No.	Sizes Included	Step Length	Over All Length	Shank Diameter
SDXL4-12MM	4, 6, 8, 10, 12mm	8.0mm	64.0mm	8mm

STRAIGHT FLUTE STEP DRILLS



Part No.	Sizes Included	Step Length	Over All Length	Shank Diameter
SDST4-12MM	4, 5, 6, 7, 8, 9, 10, 11, 12mm	3.75mm	65.5mm	8mm
SDST4-20MM	4, 6, 8, 10, 12, 14, 16, 18, 20mm	4.0mm	75.0mm	8mm
SDST5-25MM	5, 7, 9, 11, 13, 15, 17, 19, 21, 23, 25mm	4.0mm	81.8mm	10mm
SDST6-30MM	6, 8, 10, 12, 14, 16, 18, 20, 22, 24, 26, 28, 30mm	3.75mm	97.0mm	12mm



SPIRAL FLUTE STEP DRILL SET

PART NO. SDSET-1 | SET CONTENTS

Quantity	Part No.	Size min-max
1	SD4-20MM	4 - 20mm
1	SD5-25MM	5 - 25mm
1	SD6-30MM	6 - 30mm

STRAIGHT FLUTE STEP DRILL SET

PART NO. SDSTSET-1 | SET CONTENTS

Quantity	Part No.	Size min-max
1	SDST4-12MM	4 - 12mm
1	SDST5-25MM	5 - 25mm
1	SDST6-30MM	6 - 30mm

COUNTERSINKS

COUNTERSINKS CROSS HOLE HIGH SPEED STEEL



Part No.	Size	Angle	Shank Diameter
SWCS-5	2 - 5mm	90°	6mm
SWCS-10	5 - 10mm	90°	8mm
SWCS-15	10 - 15mm	90°	10mm
SWCS-20	15 - 20mm	90°	12mm
SWCS-25	20 - 25mm	90°	12mm



CROSS HOLE COUNTERSINK SET

PART NO. SWSET-05 | SET CONTENTS

Quantity	Size min-max
1	2 - 5mm
1	5 - 10mm
1	10 - 15mm
1	15 - 20mm
1	20 - 25mm

COUNTERSINKS 3 FLUTE HIGH SPEED STEEL



Part No.	Size min-max	Angle	Shank Diameter
STCS-06	3 - 6.4mm	90°	5mm
STCS-08	3 - 8.4mm	90°	6mm
STCS-10	3 - 10.4mm	90°	6mm
STCS-12	3 - 12.4mm	90°	8mm
STCS-16	3 - 16.5mm	90°	10mm
STCS-20	3 - 20.5mm	90°	10mm
STCS-25	3 - 25mm	90°	10mm
STCS-31	3 - 31mm	90°	12mm
STCS-40	3 - 40mm	90°	15mm



STSET-03

3 FLUTE COUNTERSINK SETS

PART NO. STSET-01 | SET CONTENTS

Quantity	Size min-max
1	3 - 6.4mm
1	3 - 8.4mm
1	3 - 10.4mm
1	3 - 12.4mm
1	3 - 16.5mm
1	3 - 20.5mm

PART NO. STSET-03 | SET CONTENTS

Quantity	Size min-max
1	3 - 10.4mm
1	3 - 16.5mm
1	3 - 25mm



PART NO. STSET-05 | SET CONTENTS

Quantity	Size min-max
1	3 - 8.4mm
1	3 - 12.4mm
1	3 - 20.5mm



CARBIDE BURRS DOUBLE CUT

CYLINDRICAL - SQUARE END



Part No.	Head Diameter	Flute Length	Over All Length	Shank Diameter	Style
CB-SA43	1/8"	9/16"	1-1/2"	1/8"	SA-43
CB-SA51	1/4"	1/2"	1-1/2"	1/8"	SA-51
CB-SA14	3/16"	5/8"	2"	1/4"	SA-14
CB-SA1	1/4"	5/8"	2"	1/4"	SA-1
CB-SA2	5/16"	3/4"	2-1/2"	1/4"	SA-2
CB-SA3	3/8"	3/4"	2-1/2"	1/4"	SA-3
CB-SA4	7/16"	1"	2-3/4"	1/4"	SA-4
CB-SA5	1/2"	1"	2-3/4"	1/4"	SA-5
CB-SA6	5/8"	1"	2-3/4"	1/4"	SA-6
CB-SA7	3/4"	1"	2-3/4"	1/4"	SA-7
CB-SA9	1"	1"	2-3/4"	1/4"	SA-9

CYLINDRICAL - END CUT



Part No.	Head Diameter	Flute Length	Over All Length	Shank Diameter	Style
CB-SB43	1/8"	9/16"	1-1/2"	1/8"	SB-43
CB-SB1	1/4"	5/8"	2"	1/4"	SB-1
CB-SB2	5/16"	3/4"	2-1/2"	1/4"	SB-2
CB-SB3	3/8"	3/4"	2-1/2"	1/4"	SB-3
CB-SB4	7/16"	1"	2-3/4"	1/4"	SB-4
CB-SB5	1/2"	1"	2-3/4"	1/4"	SB-5
CB-SB6	5/8"	1"	2-3/4"	1/4"	SB-6
CB-SB7	3/4"	1"	2-3/4"	1/4"	SB-7
CB-SB9	1"	1"	2-3/4"	1/4"	SB-9

CYLINDRICAL - RADIUS END



Part No.	Head Diameter	Flute Length	Over All Length	Shank Diameter	Style
CB-SC42	1/8"	9/16"	1-1/2"	1/8"	SC-42
CB-SC53	3/16"	1/2"	1-1/2"	1/8"	SC-53
CB-SC51	1/4"	1/2"	1-3/4"	1/8"	SC-51
CB-SC1	1/4"	5/8"	2"	1/4"	SC-1
CB-SC2	5/16"	3/4"	2-1/2"	1/4"	SC-2
CB-SC3	3/8"	3/4"	2-1/2"	1/4"	SC-3
CB-SC4	7/16"	1"	2-3/4"	1/4"	SC-4
CB-SC5	1/2"	1"	2-3/4"	1/4"	SC-5
CB-SC6	5/8"	1"	2-3/4"	1/4"	SC-6
CB-SC7	3/4"	1"	2-3/4"	1/4"	SC-7

BALL SHAPE



Part No.	Head Diameter	Flute Length	Over All Length	Shank Diameter	Style
CB-SD42	1/8"	-	1-1/2"	1/8"	SD-42
CB-SD51	1/4"	-	2"	1/8"	SD-51
CB-SD1	1/4"	-	2"	1/4"	SD-1
CB-SD2	5/16"	-	2-1/16"	1/4"	SD-2
CB-SD3	3/8"	-	2-1/16"	1/4"	SD-3
CB-SD4	7/16"	-	2-1/8"	1/4"	SD-4
CB-SD5	1/2"	-	2-3/16"	1/4"	SD-5
CB-SD6	5/8"	-	2-5/16"	1/4"	SD-6
CB-SD7	3/4"	-	2-7/16"	1/4"	SD-7
CB-SD9	1"	-	2-3/4"	1/4"	SD-9

OVAL SHAPE



Part No.	Head Diameter	Flute Length	Over All Length	Shank Diameter	Style
CB-SE41	1/8"	7/32"	1-1/2"	1/8"	SE-41
CB-SE1	1/4"	3/8"	2"	1/4"	SE-1
CB-SE3	3/8"	5/8"	2-3/8"	1/4"	SE-3
CB-SE5	1/2"	7/8"	2-5/8"	1/4"	SE-5
CB-SE6	5/8"	1"	2-3/4"	1/4"	SE-6
CB-SE7	3/4"	1"	2-3/4"	1/4"	SE-7

TREE SHAPE - RADIUS END



Part No.	Head Diameter	Flute Length	Over All Length	Shank Diameter	Style
CB-SF42	1/8"	1/2"	1-1/2"	1/8"	SF-42
CB-SF51	1/4"	1/2"	1-3/4"	1/8"	SF-51
CB-SF1	1/4"	3/4"	2"	1/4"	SF-1
CB-SF3	3/8"	3/4"	2-1/2"	1/4"	SF-3
CB-SF4	7/16"	1"	2-3/4"	1/4"	SF-4
CB-SF5	1/2"	1"	2-3/4"	1/4"	SF-5
CB-SF6	5/8"	1"	2-3/4"	1/4"	SF-6
CB-SF7	3/4"	1"	2-3/4"	1/4"	SF-7

TAPERED - RADIUS END



Part No.	Head Diameter	Flute Length	Over All Length	Shank Diameter	Angle	Style
CB-SL42	1/8"	1/2"	1-1/2"	1/8"	7°	SL-42
CB-SL1	1/4"	5/8"	2"	1/4"	14°	SL-1
CB-SL2	5/16"	7/8"	2-5/8"	1/4"	14°	SL-2
CB-SL3	3/8"	1-1/16"	2-13/16"	1/4"	14°	SL-3
CB-SL4	1/2"	1-1/8"	2-7/8"	1/4"	14°	SL-4
CB-SL6	5/8"	1-5/16"	3-1/16"	1/4"	14°	SL-6
CB-SL7	3/4"	1-1/2"	3-1/4"	1/4"	14°	SL-7

TREE SHAPE - POINTED END



Part No.	Head Diameter	Flute Length	Over All Length	Shank Diameter	Style
CB-SG43	1/8"	3/8"	1-1/2"	1/8"	SG-43
CB-SG1	1/4"	5/8"	2"	1/4"	SG-1
CB-SG2	5/16"	3/4"	2-1/2"	1/4"	SG-2
CB-SG3	3/8"	3/4"	2-1/2"	1/4"	SG-3
CB-SG5	1/2"	1"	2-3/4"	1/4"	SG-5
CB-SG6	5/8"	1"	2-3/4"	1/4"	SG-6
CB-SG7	3/4"	1"	2-3/4"	1/4"	SG-7

CONE SHAPE



Part No.	Head Diameter	Flute Length	Over All Length	Shank Diameter	Angle	Style
CB-SM42	1/8"	1/2"	1-1/2"	1/8"	12°	SM-42
CB-SM2	1/4"	3/4"	2"	1/4"	14°	SM-2
CB-SM4	3/8"	3/4"	2-1/2"	1/4"	28°	SM-4
CB-SM5	1/2"	1"	2-3/4"	1/4"	28°	SM-5
CB-SM6	5/8"	1-1/8"	2-7/8"	1/4"	31°	SM-6

FLAME SHAPE



Part No.	Head Diameter	Flute Length	Over All Length	Shank Diameter	Style
CB-SH41	1/8"	1/4"	1-1/2"	1/8"	SH-41
CB-SH1	1/4"	5/8"	2"	1/4"	SH-1
CB-SH2	5/16"	3/4"	2-1/2"	1/4"	SH-2
CB-SH3	3/8"	1"	2-3/4"	1/4"	SH-3
CB-SH5	1/2"	1-1/4"	3"	1/4"	SH-5
CB-SH6	5/8"	1-7/16"	3-3/16"	1/4"	SH-6
CB-SH7	3/4"	1-5/8"	3-3/8"	1/4"	SH-7

INVERTED CONE SHAPE



Part No.	Head Diameter	Flute Length	Over All Length	Shank Diameter	Angle	Style
CB-SN42	1/8"	1/8"	1-1/2"	1/8"	14°	SN-42
CB-SN1	1/4"	1/4"	2"	1/4"	10°	SN-1
CB-SN2	3/8"	3/8"	2-1/8"	1/4"	13°	SN-2
CB-SN4	1/2"	1/2"	2-1/4"	1/4"	28°	SN-4
CB-SN6	5/8"	3/4"	2-1/2"	1/4"	18°	SN-6
CB-SN7	3/4"	5/8"	2-3/8"	1/4"	30°	SN-7

CARBIDE BURRS

EXTENDED SHANK DOUBLE CUT

CYLINDRICAL - END CUT



Part No.	Head Diameter	Flute Length	Over All Length	Shank Diameter	Style
CB-SB1L6	1/4"	5/8"	6-5/8"	1/4"	SB-1L6
CB-SB3L6	3/8"	3/4"	6-3/4"	1/4"	SB-3L6
CB-SB5L6	1/2"	1"	7"	1/4"	SB-5L6

CYLINDRICAL - RADIUS END



Part No.	Head Diameter	Flute Length	Over All Length	Shank Diameter	Style
CB-SC1L6	1/4"	5/8"	6-5/8"	1/4"	SC-1L6
CB-SC3L6	3/8"	3/4"	6-3/4"	1/4"	SC-3L6
CB-SC5L6	1/2"	1"	7"	1/4"	SC-5L6

BALL SHAPE



Part No.	Head Diameter	Flute Length	Over All Length	Shank Diameter	Style
CB-SD1L6	1/4"	-	6-1/8"	1/4"	SD-1L6
CB-SD3L6	3/8"	-	6-1/4"	1/4"	SD-3L6
CB-SD5L6	1/2"	-	6-3/8"	1/4"	SD-5L6

TREE SHAPE - RADIUS END



Part No.	Head Diameter	Flute Length	Over All Length	Shank Diameter	Style
CB-SF1L6	1/4"	5/8"	6-5/8"	1/4"	SF-1L6
CB-SF3L6	3/8"	3/4"	6-3/4"	1/4"	SF-3L6
CB-SF5L6	1/2"	1"	7"	1/4"	SF-5L6

TAPERED - RADIUS END

14° Included Angle



Part No.	Head Diameter	Flute Length	Over All Length	Shank Diameter	Style
CB-SL1L6	1/4"	5/8"	6-5/8"	1/4"	SL-1L6
CB-SL3L6	3/8"	1-1/16"	7"	1/4"	SL-3L6
CB-SL4L6	1/2"	1-1/8"	7-1/8"	1/4"	SL-4L6

CARBIDE BURRS

ALUMINIUM CUT

CYLINDRICAL - SQUARE END



Part No.	Head Diameter	Flute Length	Over All Length	Shank Diameter	Style
CB-SA1-AC	1/4"	3/4"	2"	1/4"	SA-1AC
CB-SA3-AC	3/8"	3/4"	2-1/2"	1/4"	SA-3AC
CB-SA5-AC	1/2"	1"	2-3/4"	1/4"	SA-5AC
CB-SA6-AC	5/8"	1"	2-3/4"	1/4"	SA-6AC
CB-SA7-AC	3/4"	1"	2-3/4"	1/4"	SA-7AC

CYLINDRICAL - RADIUS END



Part No.	Head Diameter	Flute Length	Over All Length	Shank Diameter	Style
CB-SC1-AC	1/4"	5/8"	2"	1/4"	SC-1AC
CB-SC3-AC	3/8"	3/4"	2-1/2"	1/4"	SC-3AC
CB-SC5-AC	1/2"	1"	2-3/4"	1/4"	SC-5AC
CB-SC6-AC	5/8"	1"	2-3/4"	1/4"	SC-6AC
CB-SC7-AC	3/4"	1"	2-3/4"	1/4"	SC-7AC

BALL SHAPE



Part No.	Head Diameter	Flute Length	Over All Length	Shank Diameter	Style
CB-SD1-AC	1/4"	-	2"	1/4"	SD-1AC
CB-SD3-AC	3/8"	-	2-1/16"	1/4"	SD-3AC
CB-SD5-AC	1/2"	-	2-3/16"	1/4"	SD-5AC
CB-SD6-AC	5/8"	-	2-5/16"	1/4"	SD-6AC
CB-SD7-AC	3/4"	-	2-7/16"	1/4"	SD-7AC

OVAL SHAPE



Part No.	Head Diameter	Flute Length	Over All Length	Shank Diameter	Style
CB-SE1-AC	1/4"	3/8"	2"	1/4"	SE-1AC
CB-SE3-AC	3/8"	5/8"	2-3/8"	1/4"	SE-3AC
CB-SE5-AC	1/2"	7/8"	2-5/8"	1/4"	SE-5AC
CB-SE6-AC	5/8"	1"	2-3/4"	1/4"	SE-6AC

TREE SHAPE - RADIUS END



Part No.	Head Diameter	Flute Length	Over All Length	Shank Diameter	Style
CB-SF1-AC	1/4"	3/4"	2"	1/4"	SF-1AC
CB-SF3-AC	3/8"	3/4"	2-1/2"	1/4"	SF-3AC
CB-SF5-AC	1/2"	1"	2-3/4"	1/4"	SF-5AC
CB-SF6-AC	5/8"	1"	2-3/4"	1/4"	SF-6AC

TAPERED - RADIUS END

14° Included Angle



Part No.	Head Diameter	Flute Length	Over All Length	Shank Diameter	Style
CB-SL3-AC	3/8"	1-1/16"	2-13/16"	1/4"	SL-3AC
CB-SL4-AC	1/2"	1-1/8"	2-7/8"	1/4"	SL-4AC
CB-SL6-AC	5/8"	1-5/16"	3-1/16"	1/4"	SL-6AC
CB-SL7-AC	3/4"	1-1/2"	3-1/4"	1/4"	SL-7AC

CARBIDE BURRS SETS



CB-SET-01

PART NO. CB-SET-01 | 3/8" 5 PIECE SET

QTY	Part No.	Head Dia.	Description	Cut Style	Style
1	CB-SB3	3/8"	Cylindrical End Cut	DC	SB-3
1	CB-SC3	3/8"	Cylindrical Radius End	DC	SC-3
1	CB-SD3	3/8"	Ball Shape	DC	SD-3
1	CB-SF3	3/8"	Tree Shape Radius End	DC	SF-3
1	CB-SA3-AC	3/8"	Cylindrical	AC	SA-3

PART NO. CB-SET-02 | 3/8" 5 PIECE SET

1	CB-SB3	3/8"	Cylindrical End Cut	DC	SB-3
1	CB-SC3	3/8"	Cylindrical Radius End	DC	SC-3
1	CB-SD3	3/8"	Ball Shape	DC	SD-3
1	CB-SF3	3/8"	Tree Shape Radius End	DC	SF-3
1	CB-SA3-AC	3/8"	Cylindrical	AC	SA-3

PART NO. CB-SET-04 | 1/2" 5 PIECE SET

1	CB-SB5	1/2"	Cylindrical End Cut	DC	SB-5
1	CB-SC5	1/2"	Cylindrical Radius End	DC	SC-5
1	CB-SD5	1/2"	Ball Shape	DC	SD-5
1	CB-SF5	1/2"	Tree Shape Radius End	DC	SF-5
1	CB-SA5-AC	1/2"	Cylindrical	AC	SA-5

PART NO. CB-SET-06 | 3/8" to 1/2" 5 PIECE SET

1	CB-SB3	3/8"	Cylindrical End Cut	DC	SB-3
1	CB-SC3	3/8"	Cylindrical Radius End	DC	SC-3
1	CB-SB5	1/2"	Cylindrical End Cut	DC	SB-5
1	CB-SC5	1/2"	Cylindrical Radius End	DC	SC-5
1	CB-SF5	1/2"	Tree Shape Radius End	DC	SF-5

PART NO. CB-SET-08 | 1/4" 7 PIECE SET

1	CB-SB1	1/4"	Cylindrical End Cut	DC	SB-1
1	CB-SC1	1/4"	Cylindrical Radius End	DC	SC-1
1	CB-SD1	1/4"	Ball Shape	DC	SD-1
1	CB-SF1	1/4"	Tree Shape Radius End	DC	SF-1
1	CB-SH1	1/4"	Flame Shape	DC	SH-1
1	CB-SL1	1/4"	Taper Radius End	DC	SL-1
1	CB-SM2	1/4"	Cone Pointed End	DC	SM-2

PART NO. CB-SET-10 | 3/8" 7 PIECE SET

QTY	Part No.	Head Dia.	Description	Cut Style	Style
1	CB-SB3	3/8"	Cylindrical End Cut	DC	SB-3
1	CB-SC3	3/8"	Cylindrical Radius End	DC	SC-3
1	CB-SD3	3/8"	Ball Shape	DC	SD-3
1	CB-SF3	3/8"	Tree Shape Radius End	DC	SF-3
1	CB-SH3	3/8"	Flame Shape	DC	SH-3
1	CB-SL3	3/8"	Taper Radius End	DC	SL-3
1	CB-SM4	3/8"	Cone Pointed End	DC	SM-4

PART NO. CB-SET-12 | 1/2" 7 PIECE SET

1	CB-SB5	1/2"	Cylindrical End Cut	DC	SB-5
1	CB-SC5	1/2"	Cylindrical Radius End	DC	SC-5
1	CB-SD5	1/2"	Ball Shape	DC	SD-5
1	CB-SF5	1/2"	Tree Shape Radius End	DC	SF-5
1	CB-SH5	1/2"	Flame Shape	DC	SH-5
1	CB-SL4	1/2"	Taper Radius End	DC	SL-4
1	CB-SM5	1/2"	Cone Pointed End	DC	SM-5

PART NO. CB-SET-13 | 1/2" 8 PIECE SET

1	CB-SA5	1/2"	Cylindrical Square End	DC	SA-5
1	CB-SC5	1/2"	Cylindrical Radius End	DC	SC-5
1	CB-SD5	1/2"	Ball Shape	DC	SD-5
1	CB-SE5	1/2"	Oval Shape	DC	SE-5
1	CB-SF5	1/2"	Tree Shape Radius End	DC	SF-5
1	CB-SG5	1/2"	Tree Shape Pointed End	DC	SG-5
1	CB-SL4	1/2"	Tapered Radius End	DC	SL-4
1	CB-SM5	1/2"	Cone Shape	DC	SM-5

PART NO. CB-SET-14 | 1/4" to 1/2" 8 PIECE SET

1	CB-SB1	1/4"	Cylindrical End Cut	DC	SB-1
1	CB-SC1	1/4"	Cylindrical Radius End	DC	SC-1
1	CB-SD1	1/4"	Ball Shape	DC	SD-1
1	CB-SC3	3/8"	Cylindrical Radius End	DC	SC-3
1	CB-SD3	3/8"	Ball Shape	DC	SD-3
1	CB-SE3	3/8"	Oval Shape	DC	SE-3
1	CB-SB5	1/2"	Cylindrical End Cut	DC	SB-5
1	CB-SF5	1/2"	Tree Shape Radius End	DC	SF-5

PART NO. CB-SET-16 | 1/4" to 1/2" 8 PIECE SET - ALUMINIUM CUT

1	CB-SA1-AC	1/4"	Cylindrical End Cut	AC	SA-1
1	CB-SC1-AC	1/4"	Cylindrical Radius End	AC	SC-1
1	CB-SD1-AC	1/4"	Ball Shape	AC	SD-1
1	CB-SC3-AC	3/8"	Cylindrical Radius End	AC	SC-3
1	CB-SD3-AC	3/8"	Ball Shape	AC	SD-3
1	CB-SE3-AC	3/8"	Oval Shape	AC	SE-3
1	CB-SA5-AC	1/2"	Cylindrical End Cut	AC	SA-5
1	CB-SF5-AC	1/2"	Tree Shape Radius End	AC	SF-5

HAND DEBURRING TOOLS

HAND HELD RE-THREADERS



Part No.	Description
SHT-03	M3 X 0.5
SHT-04	M4 X 0.7
SHT-05	M5 X 0.8
SHT-06	M6 X 1.0

HAND HELD TAPER REAMER

- For sheet metal hole alignment or enlarging

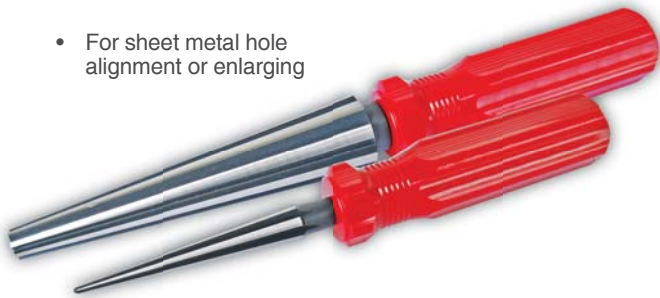

Part No.	Description
STR-12	3 - 12mm
STR-25	10 - 25mm

HAND HELD PIPE REAMER

- For deburring pipe
- 1/4" hex drive



Part No.	Description
SPR-34	10 - 34mm

HAND HELD COUNTERSINKS

- 1/4" hex drive



Part No.	Description
SHC-12	90 Degree, 12.4mm
SHC-25	90 Degree, 25mm

1/4" DRIVE CAN BE MOUNTED IN FRONT OR SIDE OF HANDLE, OR IN ELECTRIC AND CORDLESS DRILLS.



ADJUSTABLE HAND REAMERS

ADJUSTABLE HAND REAMER SETS

ADJUSTABLE HAND REAMERS

- The Groz range of Adjustable Hand Reamers are extremely useful precision tools for any engineering or auto-repair shop.
- Just 16 sizes cover diameters ranging from 9.5mm - 56.34mm (3/8" to 2-7/32").
- Suitable for use on ferrous or non ferrous metals.
- The reamer blades are made from High Speed Steel, accurately hardened 60 - 64 HRC and relief ground.
- Each adjustable reamer has a chamfer or lead on the front end of diameter 0.004" - 0.019" according to size, which helps to make a quick start in reaming operations.
- Reamers expand by loosening one adjusting nut and tightening the other.
- Concentricity within 30 microns



Part No.	Code	Type	Range
GZ-11930	AHR/8/ST	H4 - H11	11.9 - 26.98mm
GZ-11931	AHR/11/ST	H4 - H14	11.9 - 38.1mm

Part No.	Code	Type	Range
GZ-11905	AHR/5	H1	9.5 - 10.3mm
GZ-11906	AHR/6	H2	10.3 - 11.11mm
GZ-11907	AHR/7	H3	11.11 - 11.9mm
GZ-11908	AHR/8	H4	11.9 - 13.5mm
GZ-11909	AHR/9	H5	13.5 - 15mm
GZ-11910	AHR/10	H6	15 - 16.6mm
GZ-11911	AHR/11	H7	16.6 - 18.25mm
GZ-11912	AHR/12	H8	18.25 - 19.8mm
GZ-11913	AHR/13	H9	19.8 - 21.4mm
GZ-11914	AHR/14	H10	21.4 - 23.8mm
GZ-11915	AHR/15	H11	23.8 - 26.98mm
GZ-11916	AHR/16	H12	23.98 - 30.16mm
GZ-11917	AHR/17	H13	30.16 - 34.1mm
GZ-11918	AHR/18	H14	34.1 - 38.1mm
GZ-11919	AHR/19	H15	38.1 - 46mm
GZ-11920	AHR/20	H16	46.0 - 56.3mm

TAP & DIE HOLDERS

ADJUSTABLE TAP & REAMER WRENCHES FORGED STEEL & CAST IRON BAR TYPE

- The straight handle design of these tap wrenches provides greater leverage, particularly useful when working with large diameter taps.
- Extra heavy duty. Industrial quality tap wrenches - virtually unbreakable Nr. 0,00, 5 & 6 have a FORGED STEEL BODY. Nr. 7 & 8 are cast from S.G. Iron.



Part No.	Code	Tap Capacity
Forged Steel Tap & Reamer Wrenches		
GZ-09220	ARWR/SG/0	1 - 12mm
GZ-09221	ARWR/SG/00	1 - 6mm
GZ-09222	ARWR/SG/5	4 - 16mm
GZ-09223	ARWR/SG/6	4 - 20mm
Cast Iron Tap & Reamer Wrenches		
GZ-09224	ARWR/SG/7	6 - 30mm
GZ-09225	ARWR/SG/8	9 - 45mm

DIE STOCK HOLDERS STEEL CAST ROUND DIES

- Die holders are used for holding round dies, that are suited for efficient and clean cutting of external threads
- Die holders have a rugged construction



Part No.	Code	Die Size
GZ-09111	DS/0-1	1"
GZ-09113	DS/1-1-2	1-1/2"
GZ-09114	DS/0-2	2"

TAP WRENCHES T HANDLE TYPE

- Industrial quality Tap Wrenches for the professional user.
- Designed to give the user the reach and leverage needed for accurate tapping, these are used for holding taps, drills, reamers & other small tools to be turned by hand.
- CNC machined to very close tolerances with self centring powder metallurgy hardened jaws & knurled chuck sleeve for positive grip.
- Ratchet handle can be set for right or left hand operation or locked for non ratchet use. Self centring powder metallurgy hardened jaws and knurled chuck sleeve provide positive grip on taps, reamers and small tools Sliding T – Handle for fitting into tight spaces with greater leverage.
- Also available with longer body for added leverage in hard to reach places.



Part No.	Code	Body Length	Capacity
Tap Wrench Regular Length			
GZ-09361	TW/164	70mm	1.6 - 6mm
GZ-09362	TW/166	95mm	6 - 12mm
Ratchet Tap Wrench Regular Length			
GZ-09371	TW/R/161	88mm	1.6 - 6mm
GZ-09372	TW/R/162	106mm	6 - 12mm
Ratchet Tap Wrench Extra Long Length			
GZ-09375	TW/R/161L	330mm	1.6 - 6mm
GZ-09376	TW/R/162L	330mm	6 - 12mm

TM620-002
HAND RIVETER

- Durable steel body and handles
 - Chrome molybdenum steel collet
 - Comfortable rubber grip
- Nozzle sizes : 2.4mm, 3.2mm, 4.0mm, 4.8mm



TM620-006
ROTATING HEAD HAND RIVETER

- Premium cast aluminium body
 - Chrome molybdenum steel collet
 - 360° Rotating head for hard to reach places
 - Durable powder coat finish
 - Comfortable rubber grip
- 4 Nozzles included: 2.4mm, 3.2mm, 4.0mm, 4.8mm



TM620-004
HEAVY DUTY HAND RIVETER

- Premium cast aluminium body
 - Chrome molybdenum steel collet
 - Durable powder coat finish
 - Comfortable rubber grip
- 4 Nozzles included: 2.4mm, 3.2mm, 4.0mm, 4.8mm



TM620-008
EASY PULL TWIN HANDLE RIVETER

- Premium quality
 - Strong aluminium alloy body
 - High impact long lasting PVC handle
 - Chrome molybdenum steel collet
 - 3 Jaw system
 - Durable powder coat finish
- 5 Nozzles : 3.2mm, 4.0mm, 4.8mm, 6.0mm & 6.4mm



TM620-010
SHORT ARM HAND RIVETER

- Premium quality
 - Strong aluminium alloy body
 - High impact long lasting PVC handle
 - Chrome molybdenum steel collet
 - 3 Jaw system
 - Durable powder coat finish
- 5 Nozzles : 3.2mm, 4.0mm, 4.8mm, 6.0mm & 6.4mm



TM620-012
HEAVY DUTY LAZY TONG RIVETER

- Premium quality
 - Single pull action designed for fast repetitive applications
 - Strong aluminium alloy body
 - Chrome molybdenum steel collet
 - 3 Jaw system
- 5 Nozzles : 3.2mm, 4.0mm, 4.8mm, 6.0mm & 6.4mm



Part No.	Aluminium Rivet Capacity	Steel Rivet Capacity	Stainless Steel Rivet Capacity
TM620-002	2.4mm (3/32") to 4.8mm (3/16")	2.4mm (3/32") to 4.8mm (3/16")	2.4mm (3/32") to 4.0mm (5/32")
TM620-004	2.4mm (3/32") to 4.8mm (3/16")	2.4mm (3/32") to 4.8mm (3/16")	2.4mm (3/32") to 4.0mm (5/32")
TM620-006	2.4mm (3/32") to 4.8mm (3/16")	2.4mm (3/32") to 4.8mm (3/16")	2.4mm (3/32") to 4.0mm (5/32")
TM620-008	3.2mm (1/8") to 6.4mm (1/4")	3.2mm (1/8") to 6.4mm (1/4")	3.2mm (1/8") to 6.0mm (15/64")
TM620-010	3.2mm (1/8") to 6.4mm (1/4")	3.2mm (1/8") to 6.4mm (1/4")	3.2mm (1/8") to 6.0mm (15/64")
TM620-012	3.2mm (1/8") to 6.4mm (1/4")	3.2mm (1/8") to 6.4mm (1/4")	3.2mm (1/8") to 6.4mm (1/4")

TM620-014
SCREW NUT GUN

- Premium quality
- Light weight cast aluminium construction
- Single or two hand operation
- Easy change mandrels
- Sets 3, 4, 5 & 6mm rivet nuts



Part No.	Description
TM620-014	Screw Nut Gun

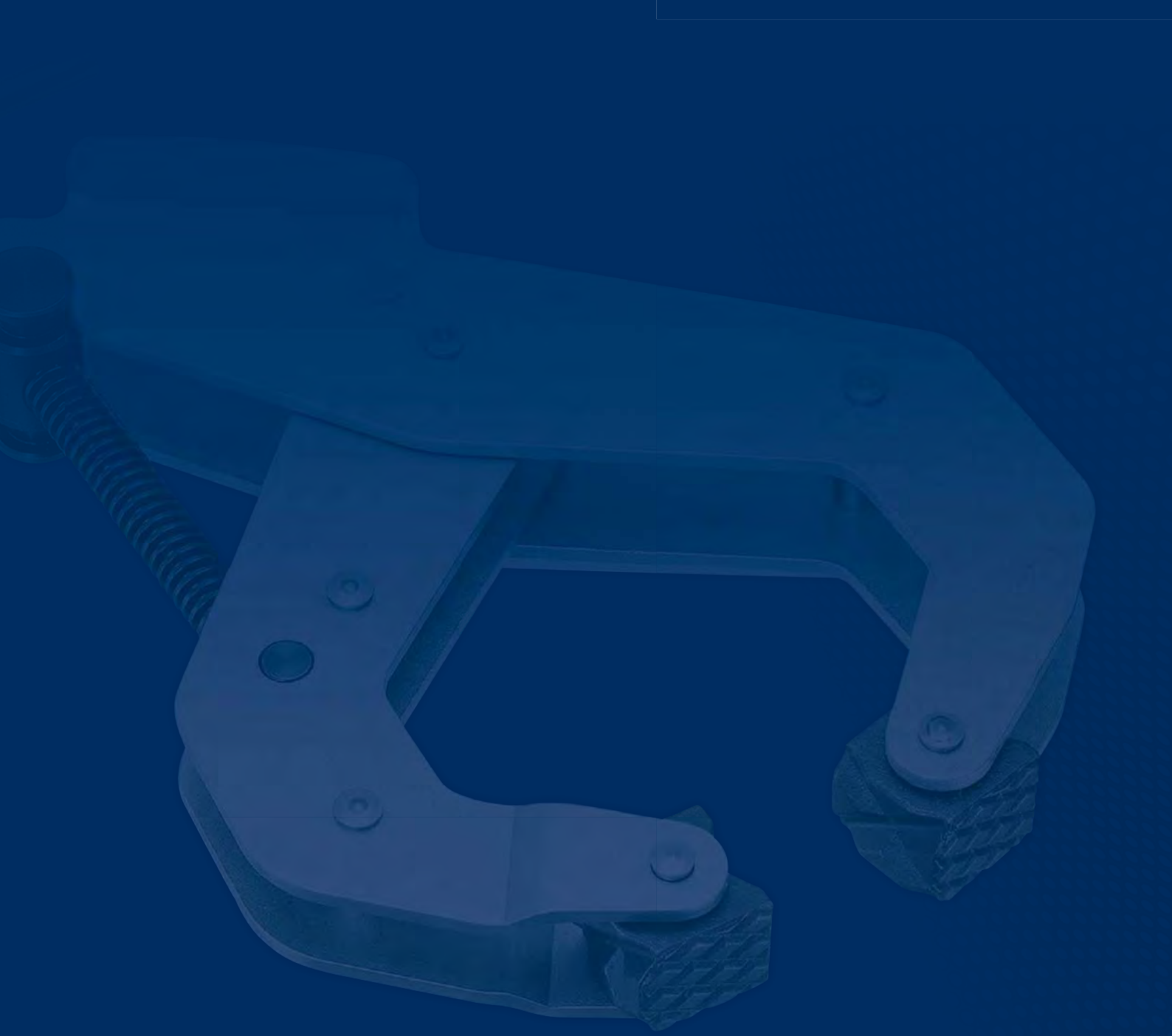

CLAMPS

Forged Steel Welding Clamps	75	Multi Purpose Clamps	83
Tool Makers Parallel Clamps	81	Locking Clamps & Pliers	84
Woodworkers Parallel Clamps	81	Sash Cramps	85
Cast Iron Clamps	82	Toggle Clamps	86

FORGED STEEL WELDING CLAMPS

Cold drawn profiled steel. Precisely controlled hardening and tempering process over the whole clamp body gives strength for high clamping force.

Nickel and chrome plating for high corrosion resistance.



Hot Forged Head

Cold Forged Pad

SPAN

DEPTH

Tempered and hot forged steel for rigidity.

Specially developed alloyed steel. Hardened spindle thread for strong tightening force.

CLAMP SELECTION GUIDE

Image	Model	Span x Depth	Clamping Force	Pg #
	General Purpose Forged Steel Clamp	100 x 50mm to 1500 x 120mm	220kg to 1000kg	75
	Heavy Duty Forged Steel Clamp	300 x 140mm to 1500 x 175mm	1200kg to 2200kg	75
	High Force Forged Steel Clamp	200 x 80mm to 1000 x 120mm	1100kg to 2600kg	76
	Pivot Handle Forged Steel Clamp	200 x 100mm to 600 x 175mm	450kg to 700kg	76
	Quick Action Lever Forged Steel Clamp	160 x 80mm to 500 x 120mm	300kg to 550kg	76
	Beam Forged Steel Clamp	250 x 120mm to 500 x 175mm	550kg to 2200kg	76
	Quick Action Beam Forged Steel	250 x 120mm to 300 x 140mm	400kg to 500kg	77
	C Clamp Deep Throat Forged Steel Clamp	50 x 100mm to 250 x 400mm	600kg to 1000kg	77
	C Clamp General Purpose Forged Steel Clamp	100 x 50mm to 400 x 175mm	900kg to 2000kg	77
	C Clamp Heavy Duty Forged Steel Clamp	50 x 50mm to 200 x 90mm	1000kg to 4000kg	77
	Self Assembled Deep Throat Clamp	400 x 300mm to 1000 x 500mm	-	78
	Cantilever Forged Steel Clamp	300 x 100mm	700kg	79
	Cantilever C Clamp	-	130kg to 850kg	79
	Tool Maker's Parallel Clamp	30 x 50mm to 70 x 100mm	-	81
	Woodworker's Parallel Jaw Clamp	160 x 80mm to 600 x 80mm	200kg	81
	Premium Woodworker's Parallel Jaw Clamp	300 x 125mm to 2500mm x 125mm	710kg	81

Image	Model	Span x Depth	Clamping Force	Pg #
	Premium F Screw Cast Iron Clamp	120 x 60mm to 600 x 175mm	200kg to 1000kg	82
	F Screw Cast Iron Clamp	200 x 120mm to 800 x 120mm	-	82
	C Clamp Cast Iron	75 x 100mm to 300 x 100mm	-	82
	Bar Clamp & Spreader	150 x 85mm to 600 x 85mm	-	83
	Spring Clamp	30 x 25mm to 80 x 70mm	-	83
	Quick Release Hand Clamp	50 x 55mm to 75 x 85mm	-	83
	Multi Adjustment Clamp	180 x 60mm to 260 x 120mm	-	83
	Quick Gear Clamp	80 x 300mm	-	83
	Cast Alloy Quick Lever Bar Clamp	150 x 85mm to 600 x 85mm	400kg	84
	Cast Alloy Multi Function Bar Clamp	150 x 85mm to 600 x 85mm	400kg	84
	Locking Plier	-	-	84
	Locking C Clamps With Swivel Pads	-	-	84
	Locking Welding Clamp	-	-	84
	Sash Bar Cramp	450 x 50mm to 1200 x 50mm	-	85
	Cramp Head Set	-	-	85
	Sash Cramp Heavy Duty	750 x 48mm to 1980 x 48mm	-	85

FORGED STEEL WELDING CLAMPS

GENERAL PURPOSE FORGED STEEL CLAMP

For general duty clamping applications. Swivel pad ensures even pressure is applied on angular workpieces.

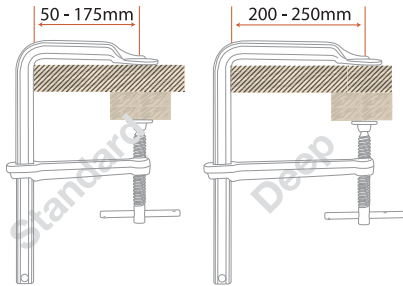

HEAVY DUTY FORGED STEEL CLAMP

Larger rail sizes & acme spindle
For heavy duty applications.

- Changeable clamping heads
- Socket drive handle

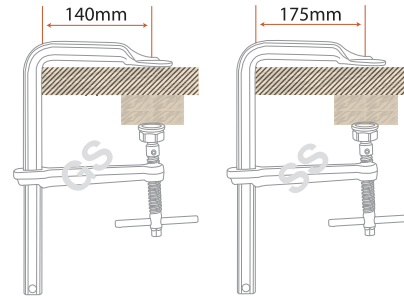

Heavy Duty Clamp Features

- Socket Drive Handle
- Changeable Clamp Heads

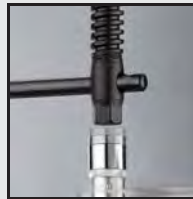

STANDARD DEPTH			
Part No.	Span x Depth	Rail Size	Clamping Force
EC-G10CS	100 x 50mm	11.5 x 5.7mm	220kg
EC-G16CS	160 x 80mm	16 x 7.5mm	300kg
EC-G20CS	200 x 100mm	19.5 x 9.5mm	450kg
EC-G25CS	250 x 120mm	22 x 10.5mm	550kg
EC-G30CS	300 x 140mm	25 x 12mm	670kg
EC-SG40CS	400 x 120mm	25 x 12mm	750kg
EC-G40CS	400 x 175mm	27 x 13mm	1000kg
EC-SG50CS	500 x 120mm	25 x 12mm	750kg
EC-SG60CS	600 x 120mm	25 x 12mm	750kg
EC-G60CS	600 x 175mm	27 x 13mm	1000kg
EC-SG80CS	800 x 120mm	27 x 13mm	1000kg
EC-G80CS	800 x 175mm	27 x 13mm	1000kg
EC-G100CS	1000 x 175mm	27 x 13mm	1000kg
EC-SG125CS	1250 x 120mm	27 x 13mm	1000kg
EC-SG150CS	1500 x 120mm	27 x 13mm	1000kg

EXTRA DEPTH			
Part No.	Span x Depth	Rail Size	Clamping Force
EC-SD30T20	300 x 200mm	30 x 15mm	800kg
EC-SD50T25	500 x 250mm	30 x 15mm	700kg
EC-SD100T25	1000 x 250mm	30 x 15mm	700kg

GS SERIES HEAVY DUTY			
Part No.	Span x Depth	Rail Size	Clamping Force
EC-GS30C	300 x 140mm	30 x 15mm	1200kg
EC-GS40C	400 x 120mm	30 x 15mm	1200kg
EC-GS50C	500 x 140mm	30 x 15mm	1200kg
EC-GS60C	600 x 120mm	30 x 15mm	1200kg
EC-GS80C	800 x 140mm	30 x 15mm	1200kg
EC-GS100C	1000 x 120mm	30 x 15mm	1200kg

SS SERIES EXTRA HEAVY DUTY			
Part No.	Span x Depth	Rail Size	Clamping Force
EC-SS30C	300 x 175mm	40 x 20mm	2200kg
EC-SS40C	400 x 175mm	40 x 20mm	2200kg
EC-SS50C	500 x 175mm	40 x 20mm	2200kg
EC-SS60C	600 x 175mm	40 x 20mm	2200kg
EC-SS100C	1000 x 175mm	40 x 20mm	2200kg
EC-SS150C	1500 x 175mm	40 x 20mm	2200kg

OPTIONAL PLASTIC SOFT PADS AVAILABLE. PROTECT YOUR WORKPIECE! SEE PAGE 80



HIGH FORCE FORGED STEEL CLAMP

Larger rail sizes & shorter depths giving high clamping force. Knurled clamping face & pad provide stronger grip on the workpiece.

- Socket Drive Handle Featured On Clamps With 30mm Or 40mm Rail Size

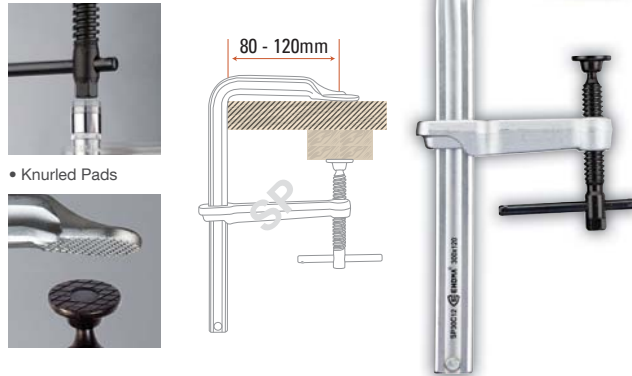

- Knurled Pads

Part No.	Span x Depth	Rail Size	Clamping Force
EC-SP20C8	200 x 80mm	27 x 13mm	1100kg
EC-SP25C8	250 x 80mm	27 x 13mm	1100kg
EC-SP30C8	300 x 80mm	27 x 13mm	1100kg
EC-SP25C10	250 x 100mm	30 x 15mm	1400kg
EC-SP40C10	400 x 100mm	30 x 15mm	1400kg
EC-SP60C10	600 x 100mm	30 x 15mm	1400kg
EC-SP30C12	300 x 120mm	40 x 20mm	2600kg
EC-SP50C12	500 x 120mm	40 x 20mm	2600kg
EC-SP100C12	1000 x 120mm	40 x 20mm	2600kg

PIVOT HANDLE FORGED STEEL CLAMP

The comfortable pivot handle makes it easier to achieve maximum clamping pressure & allows faster clamping in restricted working areas.

- Easy Operation In Restricted Working Areas

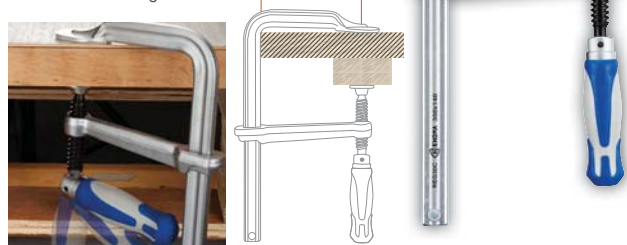

Part No.	Span x Depth	Rail Size	Clamping Force
EC-REG20C	200 x 100mm	19.5 x 9.5mm	450kg
EC-REG30C	300 x 140mm	25 x 12mm	670kg
EC-REG40C	400 x 175mm	27 x 13mm	700kg
EC-REG60C	600 x 175mm	27 x 13mm	700kg

QUICK ACTION LEVER FORGED STEEL CLAMP

Ratchet type lever prevents overloading & resists vibration. For high pressure, fast action clamping purposes.

- Fast & Easy To Use

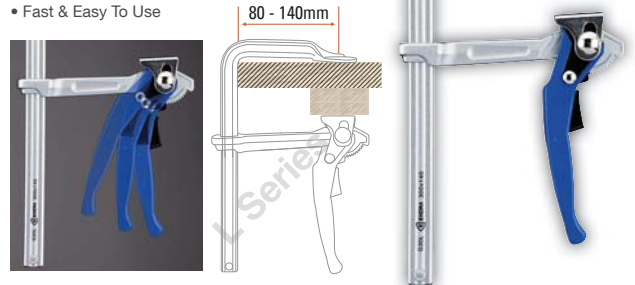

Part No.	Span x Depth	Rail Size	Clamping Force
EC-G16L	160 x 80mm	16 x 7.5mm	300kg
EC-G20L	200 x 100mm	19.5 x 9.5mm	350kg
EC-G30L	300 x 140mm	25 x 12mm	500kg
EC-G40L	400 X 120mm	25 x 12mm	550kg
EC-G50L	500 x 120mm	25 x 12mm	550kg

BEAM FORGED STEELCLAMP

U-Turn design is ideal for clamping H beam when welding

- Changeable Heads



- Socket Drive Handle

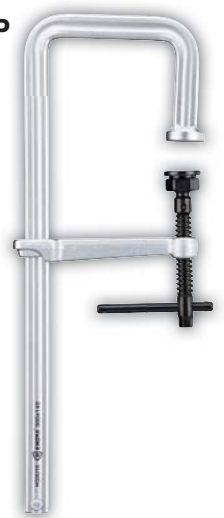
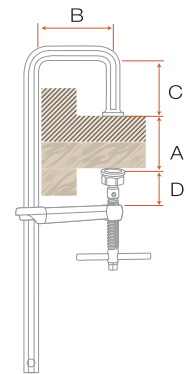

Part No.	Span x Depth (A x B)	U Depth (C)	Overpass (D)	Rail Size	Clamping Force
EC-H25U6	250 x 120	60	90	22 x 10.5	550kg
EC-H30U10	300 x 140	100	100	25 x 12	650kg
EC-H30U11	300 x 140	110	115	30 x 15	1100kg
EC-H50U11	500 x 140	110	115	30 x 15	1100kg
EC-H30U15	300 x 175	150	130	40 x 20	2200kg
EC-H40U15	400 x 175	150	130	40 x 20	2200kg
EC-H50U15	500 x 175	150	130	40 x 20	2200kg

QUICK ACTION BEAM FORGED STEEL CLAMP

As above with Ratchet type lever to prevent overloading & resist vibration. For high pressure, fast action clamping purposes

• Fast & Easy To Use

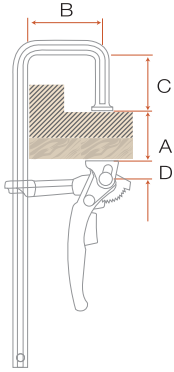

Part No.	Span x Depth (A x B)	U Depth (C)	Overpass (D)	Rail Size	Clamping Force
EC-H25U6L	250 x 120	60	10	22 x 10.5	400kg
EC-H30U10L	300 x 140	100	12	25 x 12	500kg

C CLAMP DEEP THROAT FORGED STEEL CLAMP

As per standard General Purpose C Clamp, with increased depth capacity



Part No.	Span x Depth	Rail Size	Clamping Force
EC-UC2	50 x 100mm	19.5 x 9.5mm	600kg
EC-UC3	75 x 125mm	22 x 10.5mm	600kg
EC-UC4	100 x 160mm	25 x 12mm	650kg
EC-UC5	125 x 200mm	27 x 13mm	700kg
EC-UC6	150 x 250mm	30 x 15mm	800kg
EC-UC8	200 x 350mm	36 x 18mm	850kg
EC-UC10	250 x 400mm	40 x 20mm	1000kg

C CLAMP GENERAL PURPOSE FORGED STEEL CLAMP

These General Duty C Clamps are suitable for a wide range of applications.

- Hardened Acme Spindle
- Swivel pad ensures even pressure is applied on angular workpieces.

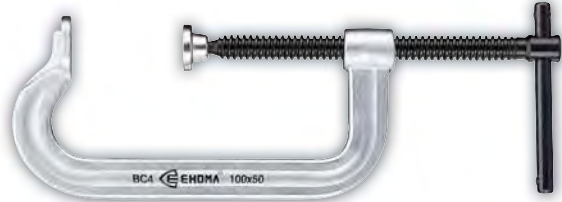

Part No.	Span x Depth	Rail Size	Clamping Force
EC-BC4	100 x 50mm	19.5 x 9.5mm	900kg
EC-BC5	125 x 65mm	19.5 x 9.5mm	850kg
EC-BC6	150 x 75mm	22 x 10.5mm	1000kg
EC-BC8	200 x 100mm	25 x 12mm	1000kg
EC-BC10	250 x 115mm	27 x 13mm	1200kg
EC-BC12	300 x 125mm	30 x 15mm	1500kg
EC-BC14	350 x 150mm	36 x 18mm	1800kg
EC-BC16	400 x 175mm	40 x 20mm	2000kg

C CLAMP HEAVY DUTY FORGED STEEL CLAMP

- Larger rail sizes & Acme spindle for heavy duty applications
- Swivel pad ensures even pressure is applied on angular workpieces



Part No.	Span x Depth	Rail Size	Clamping Force
EC-CT-2	50 x 50mm	19.5 x 9.5mm	1000kg
EC-CT-3	75 x 50mm	22 x 10.5mm	1300kg
EC-CT-4	100 x 60mm	25 x 12mm	1500kg
EC-CT-6	150 x 75mm	27 x 13mm	2200kg
EC-CT-8	200 x 90mm	30 x 15mm	4000kg

CAST IRON C CLAMPS AVAILABLE. SEE PAGE 82



SELF ASSEMBLED DEEP THROAT CLAMP

The post rail & arms are purchased separately to create a clamp that best suits your needs. Multiple arms can be attached to the post rail, as uniform rail size allows use of all arms on all post rails.



POST RAIL		
Part No.	Span (Length)	Rail Size
EC-PR36040	400mm	36 x 18mm
EC-PR36060	600mm	36 x 18mm
EC-PR36080	800mm	36 x 18mm
EC-PR36100	1000mm	36 x 18mm

FIXED & SLIDING ARM SET		
Part No.	Depth	To Suit Rail Size
EC-DSFAT363	300mm	36 x 18mm
EC-DSFAT364	400mm	36 x 18mm
EC-DSFAT365	500mm	36 x 18mm

SLIDING ARM		
Part No.	Depth	To Suit Rail Size
EC-DSAT3630	300mm	36 x 18mm
EC-DSAT3640	400mm	36 x 18mm
EC-DSAT3650	500mm	36 x 18mm

JOINT BLOCK & EXTENSION RAIL

Extend your clamping span by 1000mm. Suitable for use with all Ehoma Clamps with the equivalent rail size



EXTENSION RAIL		
Part No.	Length	Rail Size
EC-CR27100	1000mm	27 x 13mm
EC-CR30100	1000mm	30 x 15mm
EC-CR36100	1000mm	36 x 18mm
EC-CR40100	1000mm	40 x 20mm



JOINT BLOCK	
Part No.	To Suit Rail Size
EC-CJB27	27 x 13mm
EC-CJB30	30 x 15mm
EC-CJB36	36 x 18mm
EC-CJB40	40 x 20mm

CANTILEVER CLAMP FORGED STEEL CLAMP

Obtain maximum clamping pressure with minimum tightening force. Designed for clamping inward & outward in various applications.

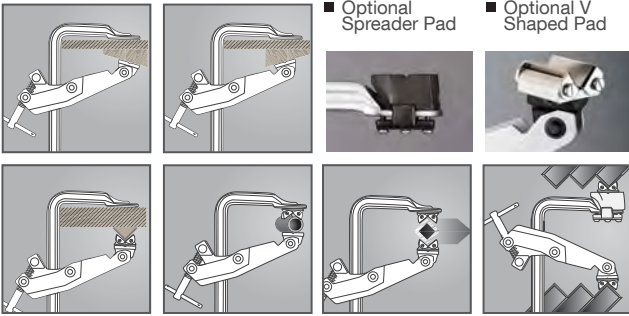
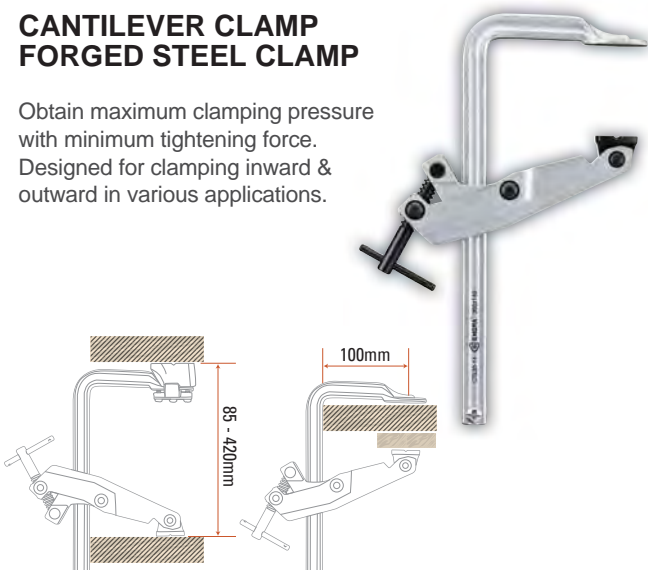

Part No.	Span x Depth	Rail Size	Clamping Force
EC-CTL30	300 x 100mm	27 x 13mm	700kg
EC-CTD-2	Spreader Pad To Suit Cantilever Clamp		
EC-CTV	V Shaped Pressure Pad To Suit Cantilever Clamp		

C CLAMP CANTILEVER FORGED STEEL CLAMP

- Cantilever clamping action, which removes the handle away from the work area
- 4 Sided Swivel Pads
- Quick adjust function on ECCTC-4.5 & ECCTC-6

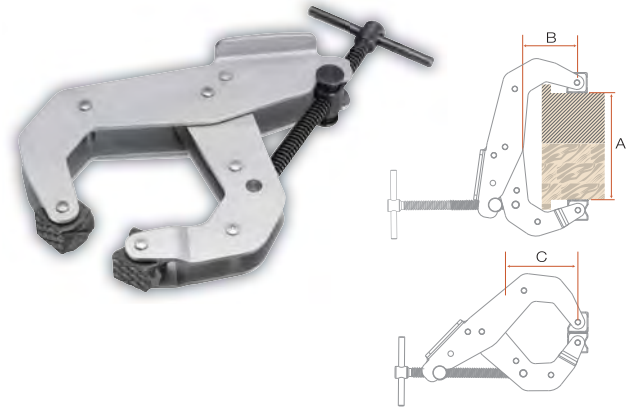

Part No.	Span (A)	Depth (B)	Depth (C)	Clamping Force
EC-CTC-1	25mm	15mm	20mm	130kg
EC-CTC-2	50mm	33mm	42mm	310kg
EC-CTC-3	75mm	35mm	49mm	500kg
EC-CTC-4.5	110mm	58mm	78mm	680kg
EC-CTC-6	150mm	110mm	128mm	850kg

CLAMP PARTS

PADS

Replacement pressure pad to suit General Purpose Clamps, Pivot Handle Clamp & C Clamps



Part No.	To Suit Rail Size
EC-PAD16CS	EC-G16CS
EC-PAD20CS	EC-G20CS, EC-G25CS,
EC-PAD30CS	EC-G30CS, EC-SG40CS, EC-G40CS, EC-SG50CS, EC-SG60CS, EC-G60CS, EC-SG80CS, EC-G80CS, EC-G100CS, EC-SG125CS, EC-SG150CS

PIVOT HANDLE

Includes Handle, Pin, Ball Bearing, Spring



Part No.	To Suit Clamps
ECP-ESP16RSET	EC-REG20C
ECP-ESP18RSET	EC-REG30C, EC-REG40C, EC-REG60C

QUICK LEVER

Includes Lever, Handle, Trigger



Part No.	To Suit Clamps
ECP-ESP20LSET	EC-G20L
ECP-ESP30LSET	EC-G30L, EC-G40L, EC-G50L

HEAVY DUTY PADS

To suit Heavy Duty Clamp & Beam Clamp

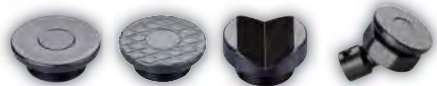

ECGSP ECGSR ECGSV ECGSPADASSY

Part No.	To Suit Rail Size
EC-GSP	30x15, 40x20mm
EC-GSR	30x15, 40x20mm
EC-GSV	30x15, 40x20mm
EC-GSPADASSY	30x15, 40x20mm

HEAVY DUTY SPINDLE & T-BAR

To suit Heavy Duty Clamp



Part No.	To Suit Rail Size
ECP-ESP30ST-H	30.0mm
ECP-ESP40ST-H	40.0mm

HEAVY DUTY ARM ASSEMBLY

Includes Arm, Spindle, T-Bar, Pad



Part No.	To Suit Rail Size	Depth
ECP-ESP3014AST-P	30.0mm	140mm
ECP-ESP4017AST-P	40.0mm	175mm

SOFT PADS

This 2 piece soft pad set is simply placed over your existing pad & is designed to stop clamps marking softer surfaces.



Part No.	To Suit Clamps
EC-PPAD20	EC-G20CS, EC-REG20C
EC-PPAD30	EC-G30CS, EC-SG40CS, EC-G40CS, EC-SG50CS, EC-SG60CS, EC-G60CS, EC-SG80CS, EC-G80CS, EC-REG30C, EC-REG40C, EC-REG50C, EC-REG60C

SPINDLE & T-BAR

To suit General Purpose Clamp

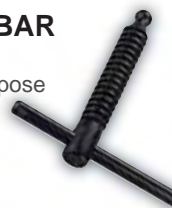

Part No.	To Clamp
ECP-ESP10TH	EC-G10CS
ECP-ESP14TH	EC-G16CS
ECP-ESP16TH	EC-G20CS, EC-G25CS,
ECP-ESP18TH	EC-G30CS, EC-SG40CS, EC-G40CS, EC-SG50CS, EC-SG60CS, EC-G60CS, EC-SG80CS, EC-G80CS, EC-G100CS, EC-SG125CS, EC-SG150CS

GENERAL PURPOSE ARM ASSEMBLY

Includes Arm, Spindle, T-Bar, Pad



Part No.	To Suit Rail Size	Depth
ECP-ESP1105AST	11.5mm	50mm
ECP-ESP1608AST	16.0mm	80mm
ECP-ESP1910AST	19.5mm	100mm
ECP-ESP2212AST	22.0mm	120mm
ECP-ESP2512AST	25.0mm	120mm
ECP-ESP2514AST	25.0mm	140mm
ECP-ESP2712AST	27.0mm	120mm
ECP-ESP2717AST	27.0mm	175mm

TOOL MAKER'S PARALLEL CLAMPS

TOOL MAKER'S PARALLEL JAW CLAMP

- Manufactured from case hardened steel 45 ± 5HRC . Parallel Clamps are designed for maximum strength and rigidity
- All sizes are equipped with a spring clip
- A retaining ring holds the loose jaw in alignment when the clamp is being opened or closed. The ends of the jaws are rounded to permit clamping under shoulders or in recesses
- These clamps are extremely useful for holding work together in tapping, drilling & on various machine setups



Part No.	Code	Span x Depth
GZ-35601	PC/1	30 x 50mm
GZ-35602	PC/2	44 x 63mm
GZ-35603	PC/3	56 x 75mm
GZ-35604	PC/4	70 x 100mm

WOODWORKER'S PARALLEL CLAMPS

WOODWORKER'S PARALLEL JAW CLAMP

- The large clamping area and parallel jaws allow secure even clamping of the work piece and prevent damage
- Anti-slip system prevents the lower rail slipping or un-clamping
- Can be used as a spreader



Part No.	Span x Depth	Spreading	Rail Size	Weight	Clamping Force
EC-PJ16	160 x 80mm	172-270mm	20 x 5mm	0.6kg	200kg
EC-PJ30	300 x 80mm	172-415mm	20 x 5mm	0.7kg	200kg
EC-PJ60	600 x 80mm	172-720mm	20 x 5mm	0.9kg	200kg

PREMIUM WOODWORKER'S PARALLEL JAW CLAMP

- The large clamping area and parallel jaws allow secure & even clamping of the work piece and prevents damage
- Anti-slip system prevents the lower rail slipping or un-clamping
- Workpiece platform prevents direct contact between the workpiece and the rail
- Replaceable pressure caps protect delicate surfaces and are resistant to glue, paint and grease solvents
- Can be used as a spreader
- Large 29mm x 9mm rail size



Part No.	Span x Depth	Spreading	Weight	Clamping Force
EC-PJH30	300 x 125mm	245-435mm	2.03kg	710kg
EC-PJH60	600 x 125mm	245-735mm	2.57kg	710kg
EC-PJH80	800 x 125mm	245-935mm	2.93kg	710kg
EC-PJH100	1000 x 125mm	245-1135mm	3.28kg	710kg
EC-PJH125	1250 x 125mm	245-1385mm	3.73kg	710kg
EC-PJH150	1500 x 125mm	245-1635mm	4.18kg	710kg
EC-PJH200	2000 x 125mm	245-2135mm	5.07kg	710kg
EC-PJH250	2500 x 125mm	245-2635mm	5.96kg	710kg

CAST IRON CLAMPS

PREMIUM F SCREW CLAMP

- Premium quality F screw clamp manufactured by Ehoma
- High-quality profiled rail, serrated to prevent slipping
- Malleable cast iron arms
- Two piece comfortable handle
- Replaceable rubber pressure pads both on the head and clamping pad

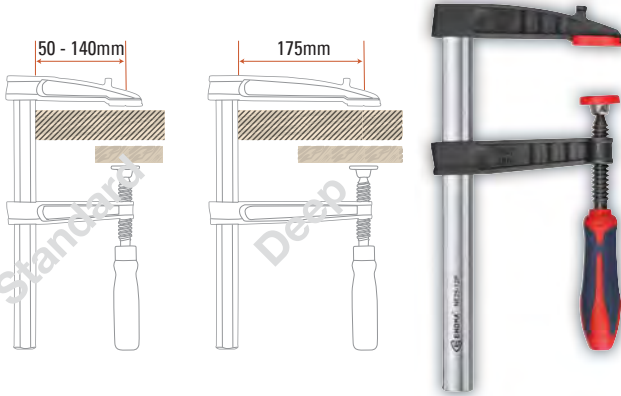

Part No.	Span x Depth	Rail Size	Clamping Force
EC-NB12-6P	120 x 60mm	20 x 5mm	200kg
EC-NC16-8P	160 x 80mm	25 x 6mm	270kg
EC-ND20-10P	200 x 100mm	27 x 7mm	400kg
EC-NE25-12P	250 x 120mm	29 x 9mm	500kg
EC-NF30-14P	300 x 140mm	32 x 10mm	550kg
EC-NF40-17P	400 x 175mm	32 x 10mm	1000kg
EC-NF60-17P	600 x 175mm	32 x 10mm	1000kg

F SCREW CLAMP

- Malleable cast jaws for strength and durability
- Serrated slip resistant profiled rail
- Rubber grip handle
- Removable soft pads



Part No.	Span x Depth
TC-F200120	200 x 120mm
TC-F250120	250 x 120mm
TC-F300120	300 x 120mm
TC-F400120	400 x 120mm
TC-F500120	500 x 120mm
TC-F600120	600 x 120mm
TC-F800120	800 x 120mm

C CLAMP

- Cast iron construction



Part No.	Span x Depth
TC-C075	75 x 100mm
TC-C100	100 x 100mm
TC-C150	150 x 100mm
TC-C200	200 x 100mm
TC-C250	250 x 100mm
TC-C300	300 x 100mm

MULTI PURPOSE CLAMPS

BAR CLAMP & SPREADER



- Durable plastic construction
- Removable rubber pressure pads
- Rubber grip handle
- Quick release lever
- Head can be placed on opposite end to create a spreader

Part No.	Span x Depth	Spreading Capacity
TC-6PT	150 x 85mm	167 - 350mm
TC-12PT	300 x 85mm	167 - 500mm
TC-18PT	450 x 85mm	167 - 650mm
TC-24PT	600 x 85mm	167 - 800mm

QUICK GEAR CLAMP

- Quick gear clamping and releasing mechanism
- Removable pads



Part No.	Span x Depth	Rail Size
TC-QG12	80 x 300mm	19 x 6mm

SPRING CLAMP

- Durable plastic construction
- Light weight
- Soft rubber handle
- Extra strong grip



Part No.	Span x Depth
TC-SP3	30 x 25mm
TC-SP4	40 x 35mm
TC-SP6	60 x 55mm
TC-SP9	80 x 70mm

QUICK RELEASE HAND CLAMP



- Durable plastic construction & metal locking mechanism
- Swivel pads
- Serrated edge
- Quick release lever

Part No.	Span x Depth
TC-107	50 x 55mm
TC-109	75 x 85mm

MULTI ADJUSTMENT CLAMP



- Durable plastic construction & metal locking mechanism
- Movable arm positions to best suit the application
- Quick release lever
- Rubber grip handle
- Swivel pads

Part No.	Span x Depth
TC-0179	180 x 60mm
TC-0169	260 x 100mm
TC-0159	260 x 120mm

**QUICK LEVER BAR CLAMP
CAST ALLOY CONSTRUCTION**

This clamp has all of the great features of the multi function one hand bar clamp & spreader, but with a single action quick clamping mechanism.

Slide the tool into position, then clamp the work with one movement of the lever!

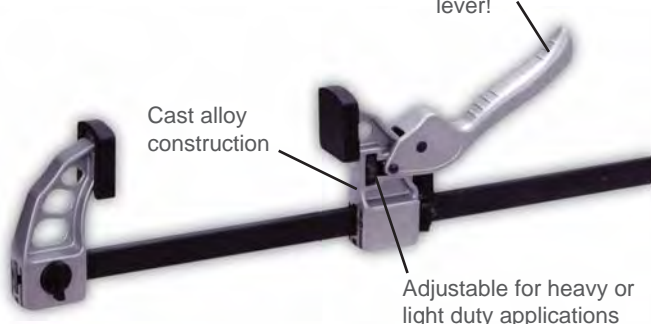

Part No.	Span x Depth	Spreading Capacity	Clamping Force
EC-TC-6HA	150 x 85mm	170 - 365mm	400kg
EC-TC-12HA	300 x 85mm	170 - 515mm	400kg
EC-TC-18HA	450 x 85mm	170 - 665mm	400kg
EC-TC-24HA	600 x 85mm	170 - 815mm	400kg

**CAST ALLOY BAR CLAMP
MULTI FUNCTION**



Part No.	Span x Depth	Spreading Capacity	Clamping Force
EC-TC-6A	150 x 85mm	170 - 365mm	400kg
EC-TC-12A	300 x 85mm	170 - 515mm	400kg
EC-TC-18A	450 x 85mm	170 - 665mm	400kg
EC-TC-24A	600 x 85mm	170 - 815mm	400kg

**LOCKING CLAMPS
& PLIERS**

LOCKING PLIER



Part No.	Description
H304	10" Locking Plier

LOCKING C CLAMPS WITH SWIVEL PADS



Part No.	Description
H307/11SP	11" Locking "C" Clamp With Swivel Pads
H307/18SP	18" Locking "C" Clamp With Swivel Pads

LOCKING WELDING CLAMP



Part No.	Description
H313	9" Locking Welding Clamp

SASH CRAMPS

SASH BAR CRAMPS

Bar cramps are especially useful for clamping large section workpieces during fabrication, gluing in joinery, carpentry and boat building.

The bars are made from drawn steel with a section of 32mm x 6mm. Malleable iron head and slides provide rigidity and strength even under heavy tension. Both head and slide have a flat bottom allowing the bar to stand upright without support. The head is fitted square to the bar with 1.5° to 2° taper for true parallel clamping action.

Main screw and handle are made from high-grade steel and have a blackened finish for increased resistance to corrosion. The screw has rolled Acme threads that impart extra strength and are wear resistant.

Features:

- Throat depth : 50mm (2")
- Width of clamp face : 30mm (1-3/16")

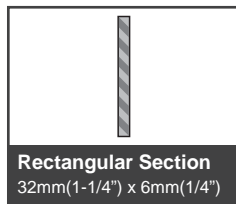

Part No.	Code	Bar Length	Clamping Capacity
GZ-39110	SBC/24	600mm	450mm
GZ-39111	SBC/30	750mm	600mm
GZ-39112	SBC/36	900mm	750mm
GZ-39113	SBC/42	1050mm	900mm
GZ-39114	SBC/48	1200mm	1050mm
GZ-39115	SBC/54	1350mm	1200mm

CRAMP HEAD SET

Cramp heads are a low cost alternative to the full size T Bar and Sash Bar Cramps. A bar cramp of any length can be made by using a piece of timber 25mm(1") thick. The timber is drilled with holes producing a light duty bar cramp as strong and as true as the timber chosen. The heads are made from malleable iron, the handle screw and pin from high quality steel for hard wearing long life. Blackened screw has rolled Acme threads for extra strength and resistance to wear.

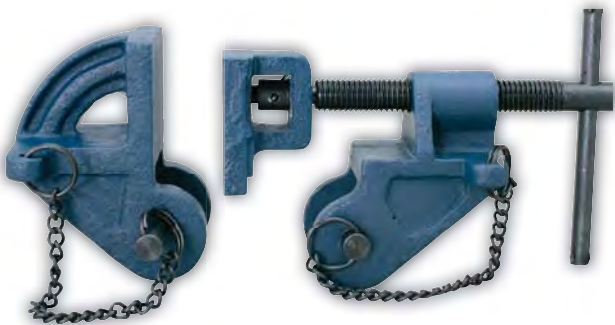

Part No.	Code	Description
GZ-39120	CHST/25-25	Cramp Head Set

SASH CRAMPS HEAVY DUTY T BAR

A robust set of cramps designed for applications that require extra resilience under extreme pressure, these can be permanently fixed onto the workbench as well.

The "T" section bar is made from special cold drawn steel with a section of 41mm x 25mm which offers great resistance to bending in use. Malleable iron head and slide allow these cramps to be used in extra heavy duty applications. The main screw has rolled Acme threads for smooth movement and increased resistance to wear. The sliding head is fastened to the T Bar by inserting a steel pin through any of the locating holes on the bar. The main screw, handle and pins are blackened for increased resistance to corrosion.

Features:

- Throat depth : 48mm (1-7/8")
- Width of clamp face : 54mm (2-1/8")

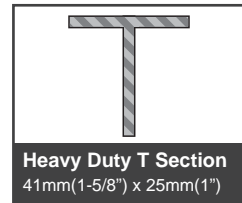

Part No.	Code	Bar Length	Clamping Capacity
GZ-39100	TBC/3	900mm	750mm
GZ-39101	TBC/4	1200mm	1050mm
GZ-39102	TBC/5	1500mm	1350mm
GZ-39103	TBC/6	1800mm	1650mm
GZ-39151	TBC/7	2100mm	1980mm

TOGGLE CLAMPS

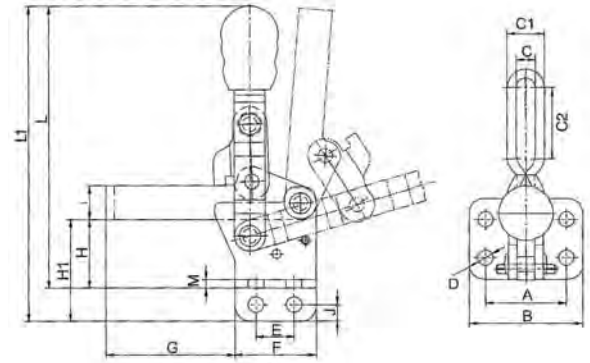

VERTICAL HANDLE

- Flanged base type
- Straight handle

Part No.	Hold Capacity	Spindle Type	Bar Type	Bar Opens	Handle Opens	Weight	A	B	C	C1	C2	D	E	F	G	H	I	J	L	M
CH-101-A	50kg	Cushion	U Bar	100°	56°	60g	23.8	33.3	5	9	17.5	4.4	15.9	25.4	26	19	8	4.8	77	2
CH-10752-B	75kg	Bolt	U Bar	195°	125°	50g	24	34	5.5	9.5	17	4.4	16	26	31	16	9	5	86.5	2
CH-12050	91kg	Cushion	Solid	100°	60°	170g	27	39.7	-	-	-	5.2	12.7	25.4	32.9	22.7	9.8	6.4	97.3	3
CH-11401	100kg	Bolt	Solid	95°	65°	200g	30	44	6.3	-	-	6.3	18	33	34	21.5	13	7	110	3
CH-11502-B	150kg	Bolt	U Bar	185°	110°	230g	26.8	37.8	6.2	12.2	24.5	5.1	12.7	27	43	23	11	5.4	123	3
CH-101-D-15	180kg	Cushion	U Bar	100°	60°	412g	31	42	9.4	15.4	132.7	6.3	19	39.4	154	36	14	5.5	145	3
CH-101-E-20	180kg	Cushion	U Bar	100°	60°	440g	31	42	9.4	15.4	182.7	6.3	19	39.4	204	36	14	5.5	145	3
CH-12205	182kg	Cushion	U Bar	101°	57°	620g	34.9	54	8.7	14.7	79.4	7.2	28.6	49.2	106.3	50.8	19	9.6	200	3
CH-11421	200kg	Bolt	U Bar	94°	45°	370g	33	50	11	17	-	8.5	24	43	63	38	16	8.5	139	3
CH-12130	227kg	Cushion	U Bar	100°	60°	355g	31.8	46	8.7	14.7	47.6	7.2	19	34.9	71.4	31.8	16	7.1	140	3
CH-12132	227kg	Cushion	U Bar	100°	60°	370g	31.8	46	8.7	14.7	71.4	7.2	19	34.9	95.2	31.8	16	7.1	140	3
CH-12265	340kg	Cushion	U Bar	105°	58°	635g	45.3	64.3	11	19	62.5	8.7	31.8	49.2	85.1	44	19	9.5	202	3
CH-101-EL	360kg	Cushion	U Bar	90°	60°	860g	45	65	11	19	52.3	8	41	62	85	47	18	10	230	4
CH-101-H	450kg	Bolt	U Bar	101°	63°	1250g	43	70	16.5	24.5	90.5	9	40	70	128	60	20.8	13.5	280	4
CH-10247	450kg	Bolt	U Bar	115°	68°	1250g	45.2	64.2	13.4	23.4	79.4	8.7	31.8	50.8	125.4	51	22.5	9.5	225.4	5

VERTICAL HANDLE

- Flanged base type
- Tee handle

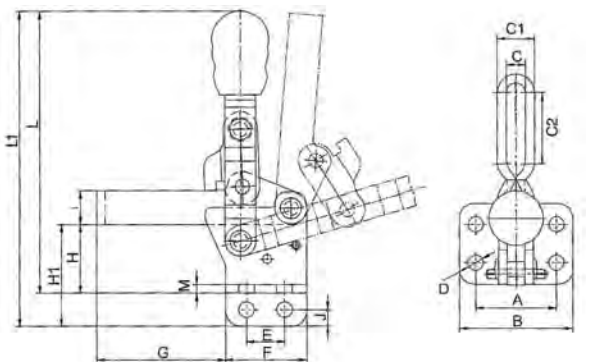
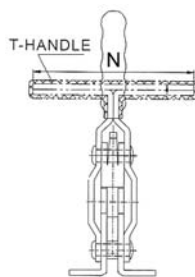

Part No.	Hold Capacity	Spindle Type	Bar Type	Bar Opens	Handle Opens	Weight	A	B	C	C1	C2	D	E	F	G	H	I	J	L	M	N
CH-12131	227kg	Cushion	U Bar	100°	60°	370g	31.8	46	8.7	14.7	71.4	7.2	19	34.9	71.4	31.8	16	7.1	140	3	87
CH-12133	227kg	Cushion	U Bar	100°	60°	400g	31.8	46	8.7	14.7	71.4	7.2	19	34.9	95.2	31.8	16	7.1	140	3	87
CH-12285	340kg	Cushion	U Bar	105°	58°	710g	45.3	64.3	11	19	62.5	8.7	31.8	49.2	85.1	44	19	9.5	152	3	129

VERTICAL HANDLE

- Straight base type
- Straight handle

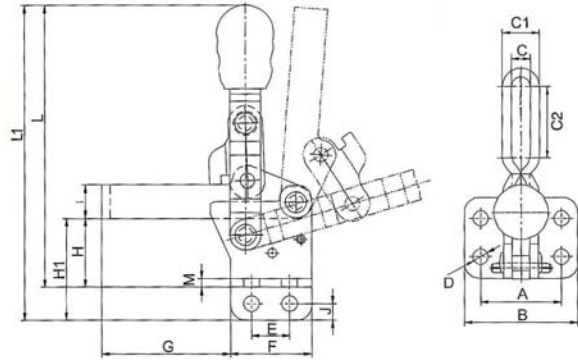

Part No.	Hold Capacity	Spindle Type	Bar Type	Bar Opens	Handle Opens	Weight	A	B	C	C1	C2	D	E	F	G	H1	I	J	L1	M
CH-10751-B	75kg	Bolt	U Bar	195°	125°	50g	-	-	5.5	9.5	17	4.4	16	26	31	28	9	5	98	2
CH-11501-B	150kg	Bolt	U Bar	185°	110°	230g	-	-	6.2	12.2	24.5	5.1	12.7	27	43	33.4	11	5.4	135	3
CH-12210	182kg	Cushion	U Bar	101°	57°	620g	-	-	8.7	14.7	79.4	7.2	28.6	49.2	106.3	70.4	19	9.6	220	3
CH-12137	227kg	Cushion	U Bar	100°	60°	370g	-	-	8.7	14.7	71.4	7.2	19	34.9	95.2	46.9	16	7.1	154	3
CH-12270	340kg	Cushion	U Bar	105°	58°	635g	-	-	11	19	62.5	8.7	31.8	49.2	85.1	67.2	19	9.5	224	3
CH-10248	450kg	Bolt	U Bar	115°	68°	1250g	-	-	13.4	23.4	79.4	8.7	31.8	50.8	125.4	67	22.5	9.5	241	5

HORIZONTAL HANDLE

- Flanged base type

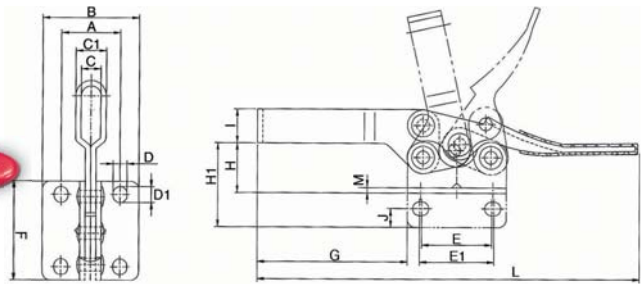

Part No.	Hold Capacity	Spindle Type	Handle Type	Bar Opens	Handle Opens	Weight	A	B	C	C1	D	D1	E	E1	F	G	H	I	J	L	M
CH-20400	20kg	Bolt	Flat	55°	60°	25.5g	15	24.5	5	8	4	5.75	11.3	14.8	24	17.6	9.8	6.5	4.75	66	1.5
CH-201-B	90kg	Cushion	Flat	85°	60°	130g	22	36	7.4	11.4	5.2	6.4	25.4	27.8	37	56.2	25.4	12.7	7	142	2
CH-201-C	100kg	Cushion	Straight	79°	92°	147g	25.0	38	7	11	5	5	28	28	40	50	26	13	6.5	146	2
CH-225-D	227kg	Cushion	Flat	90°	65°	265g	22.2	35	8.7	14.7	6.7	9	20.8	25.4	38	70	34.9	12.7	6.4	168	3
CH-22165	250kg	Cushion	Flat	96°	88°	285g	22.2	34.9	8.7	14.7	7.1	10.3	25.4	31.8	55.5	71.4	33.3	14.3	6.34	185	3
CH-20235	340kg	Cushion	Straight	85°	50°	700g	41.3	57.2	11	19	8.3	8.3	41.3	41.3	57.1	107	44.5	19	7.9	292	4
CH-200-W	400kg	Cushion	Straight	75°	77°	600g	30.0	50	12.6	19	10	10	42	42	70	60	54	20.5	10	240	3
CH-203-F	2270kg	Cushion	Straight	85°	58°	340g	29	47	9.4	15.4	7	7	41	41	57	57	34.4	16	9	193	3

HORIZONTAL HANDLE

- Straight base type

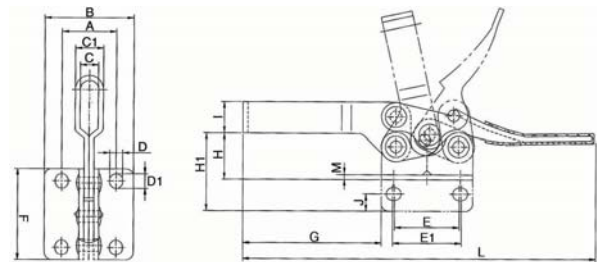

Part No.	Hold Capacity	Spindle Type	Handle Type	Bar Opens	Handle Opens	Weight	A	B	C	C1	D	D1	E	E1	F	G	H1	I	J	L	M
CH-201-BI	90kg	Cushion	Flat	85°	60°	130g	-	-	7.4	11.4	5.2	6.4	25.4	27.8	37	56.2	37.9	12.7	7	142	2
CH-225-DI	227kg	Cushion	Flat	90°	65°	265g	-	-	8.7	14.7	6.7	9	20.8	25.4	38	70	48.7	12.7	6.4	168	3
CH-22170	250kg	Cushion	Flat	96°	88°	285g	-	-	8.7	14.7	7.1	10.3	25.4	31.8	55.5	71.4	45.7	14.3	6.34	185	3
CH-20236	340kg	Cushion	Straight	85°	50°	700g	-	-	11	19	8.3	8.3	41.3	41.3	57.1	107	63	19	7.9	292	4

HORIZONTAL HANDLE

- Side mount type

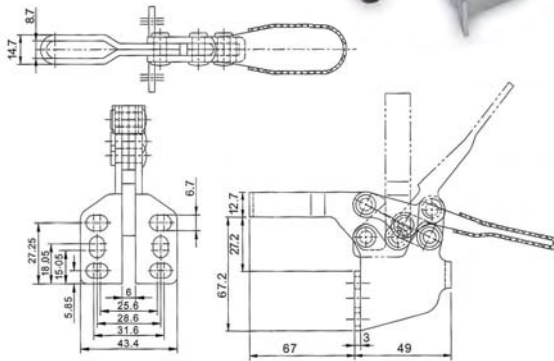

PART NO. CH-225-DSM

Holding Capacity	Spindle Type	Bar Type	Bar Opens	Handle Opens	Weight
227kg	Cushion	U Bar	90°	65°	315g

PUSH / PULL TYPE

- Threaded Collar Mount Type

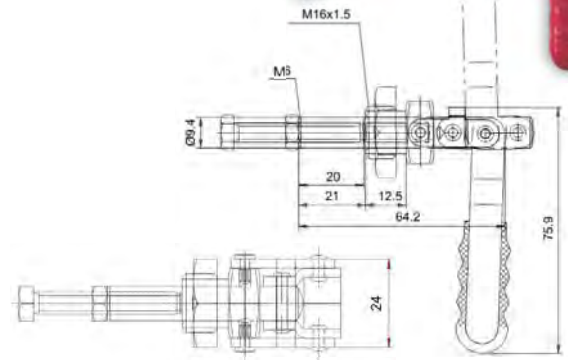

PART NO. CH-36202M

Holding Capacity	Spindle Type	Bar Type	Plunger Stroke	Handle Opens	Weight
91kg	Bolt	U Bar	20mm	180°	113g

PUSH / PULL TYPE

- Alloy base

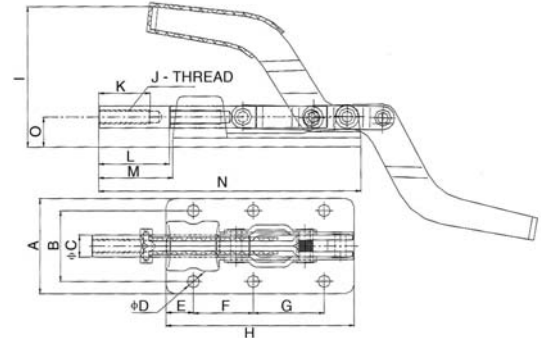

Part No.	Hold Capacity	Plunger Stroke	Handle Opens	Weight	A	B	ΦC	ΦD	E	F	G	H	I	J	L	M	N	O
CH-302-FM	136kg	32mm	180°	300g	56	41	11	5.5	11	35	-	91	78	M8 X 1.25	32	49	150	24.6
CH-36092M	180kg	32mm	180°	397g	55.6	41.3	12.7	5.2	7	34	-	92	78	M8 X 1.25	32	38	130	24.6
CH-30607M	318kg	41.3mm	180°	700g	55.6	41.3	12.7	7.1	15.9	34.9	41.3	109.5	83	M8 X 1.25	41.3	43.7	152.7	17.5
CH-36010M	364kg	40.9mm	180°	800g	57.2	41.3	15.7	8.7	7.9	41.3	-	57.2	114.8	M10 X 1.5	40.9	-	171.4	44.4
CH-36330M	1136kg	50.8mm	180°	1050g	57	41.3	15.8	8.7	12.7	34.9	41.3	127.8	72	M10 X 1.5	50.8	52.4	180.2	20.6

PUSH / PULL TYPE

- Iron base

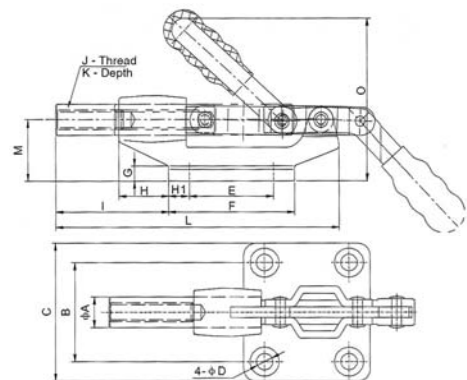

Part No.	Hold Capacity	Plunger Stroke	Handle Opens	Weight	ΦA	B	C	ΦD	E	F	G	H	H1	I	J	K	L	M	O
CH-304-CM	227kg	32mm	185°	340g	12.7	41.1	57.2	6.7	35	52.4	4.8	20.6	8.7	54.8	M8X1.25	30.2	125.7	25.4	74.2
CH-305-EM	386kg	42mm	185°	580g	16	41.1	57.2	8.3	41.1	58.8	4.8	31.8	8.8	76	M10X1.50	39.2	158.2	31.8	119.5
CH-305-HMT	680kg	60mm	185°	1580g	19.2	50.8	71.4	8.3	50.8	73.2	6.4	50.8	11.2	119.8	M12 x1.75	49.2	235	44.4	247
CH-304-HM	680kg	60mm	185°	1480g	19.2	50.8	71.4	8.3	50.8	73.2	6.4	50.8	11.1	119.8	M12X1.75	49.2	235	44.4	133.4

PNEUMATIC POWERED

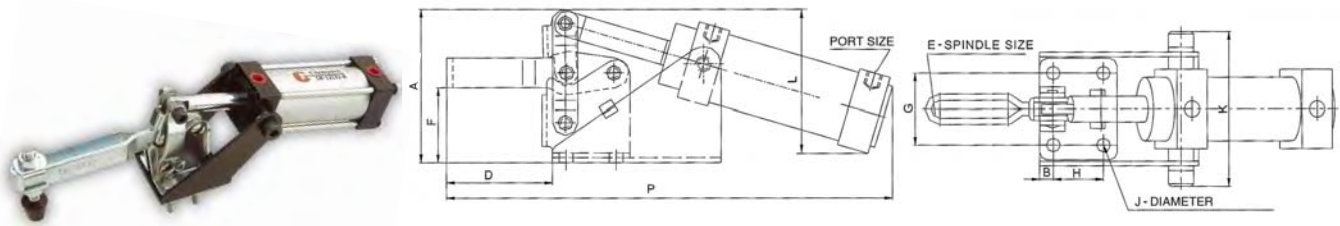

Part No.	Hold Capacity	Spindle Type	Bar Type	Bar Opens	Port Size	Weight	A	B	D	E	F	G	H	J	K	L	P
CH-12050-UA	91kg	Cushion	Solid bar	92°	G 1/8"	620g	57	6.3	35	¼ -20 x 1- ¾	25.7	27	12.7	5.2	69	51	185
CH-12130-A	227kg	Cushion	U Bar	92°	G 1/8"	900g	75.4	11	68	5/16-18 x 2- ½	34.8	31.8	19	7.1	74	75	246
CH-12132-A	227kg	Cushion	U Bar	92°	G 1/8"	900g	75.4	11	88	5/16-18 x 2- ½	34.8	31.8	19	7.1	74	75	270
CH-12265-A	340kg	Cushion	U Bar	86°	G 1/8"	1640g	97	8.7	92	3/8-16 x 3- ½	47.2	45.2	31.8	8.7	98	92	302
CH-10247-A	450kg	Bolt	U Bar	95°	G 1/8"	3620g	110	9.5	125.4	½ -12 x 3	56.8	45.2	31.8	8.7	113	105	407

LATCH CLAMPS

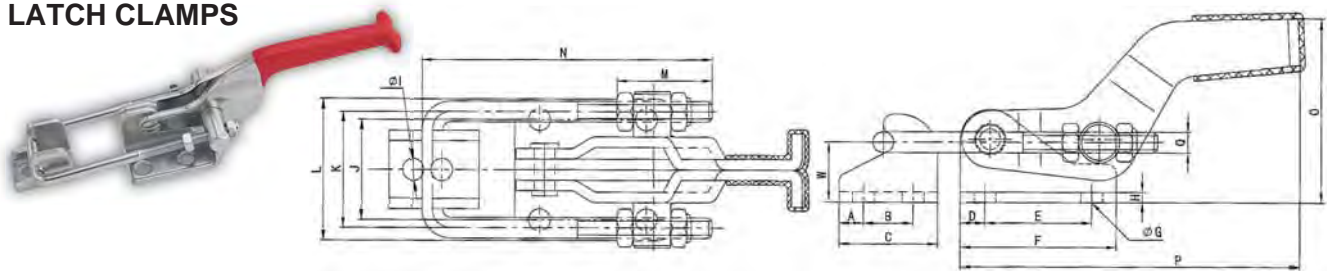

Part No.	Hold Capacity	Weight	A	B	C	D	E	F	G	H	I	J	K	L	M	N	O	P	Q	W
CH-40323	163kg	70g	5	10	20	5.2	15.9	26.2	4.4	2	4.4	19	19	28.2	24	57	29.3	75	M4 X 0.7	12
CH-431	318kg	225g	6.8	12	25.4	6.4	19	39.7	6.7	3	6.3	31.6	27	44.4	38	87	41.3	123.7	M5 X 1.0	12.2
CH-431SS	318kg	225g	6.8	12	25.4	6.4	19	39.7	6.7	3	6.3	31.6	27	44.4	38	87	41.3	123.7	M5 X 1.0	12.2
CH-40341	900kg	680g	9.5	19.2	38.1	9.5	41.3	60.3	8.6	4	8.5	38.1	44.5	54	52	115	74	168.5	M8 X 1.25	23.2

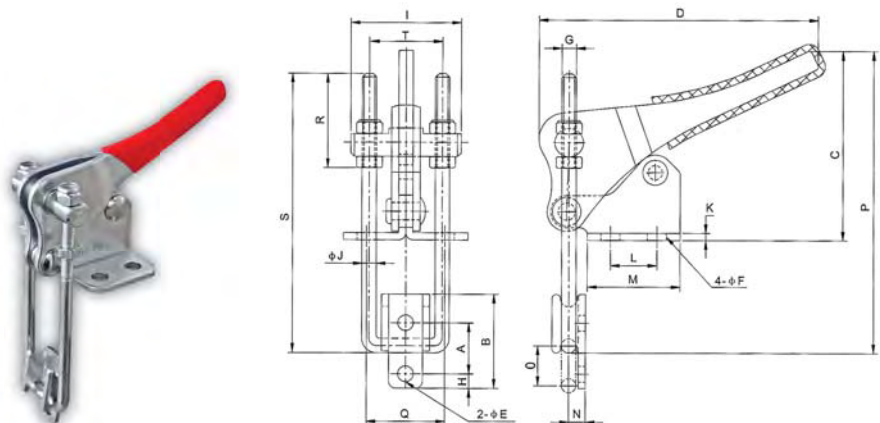

CORNER LATCH CLAMP

Part No.	Hold Capacity	Weight	A	B	C	D	E	F	G	H	I	J	K	L	M	N	O	P	Q	R	S	T
CH-40324	225kg	100g	14.3	25.4	53.3	79	4.4	5.3	M4 X 0.7	4	31	4	2	13	26	4.7	11.1	85	22	26.5	78.5	20.5
CH-40334	450kg	290g	20.6	38.1	61.9	120	7.1	7.1	M6 X 1.0	7.1	41.3	6.34	3	19.1	33.3	8.7	17.5	108.5	25.4	40.5	114	28
CH-40344	900kg	660g	27	54	88.7	130.2	8.7	8.7	M8 X 1.25	9.5	60.3	7.9	4	31.8	47.6	12.7	28.6	150	36.5	58	154	44.5



GROZ ENGINEER'S TOOLS

Set Up Tools	92	Bench Vises	118
Marking Tools	99	Hobby Vises	119
Measuring Tools	100	Punches	120
Precision Measuring Tools	106	Chisels & Bolsters	126
Machine Tool Accessories	111	Tweezers	127
Machine Vises Precision	113	Wheel Dressers	127
Premium Drill Press Vises	116	Led Lights	128
General Purpose Drill Press Vises	117		



GROZ



Engineer's Tools

www.groz.com.au

SET UP TOOLS

ENGINEER'S PRECISION SQUARES INTERNAL & EXTERNAL SQUARENESS AS PER BS 939 GRADE B

- For setting up & checking jobs where extreme accuracy is required.
- Both the blade and stock are precisely ground to ensure straightness and parallelism. Working edges of the blades are lapped which further enhances accuracy.
- A groove on the inner corner of the stock aids in the clearance of burrs and dirt.



Part No.	Code	Blade Length L1	Blade Length L2
GZ-01000	SS/A/2	50mm	50mm
GZ-01001	SS/A/3	75mm	60mm
GZ-01002	SS/A/4	100mm	75mm
GZ-01003	SS/A/6	150mm	100mm
GZ-01004	SS/A/8	200mm	125mm
GZ-01006	SS/A/10	250mm	165mm
GZ-01007	SS/A/12	300mm	210mm

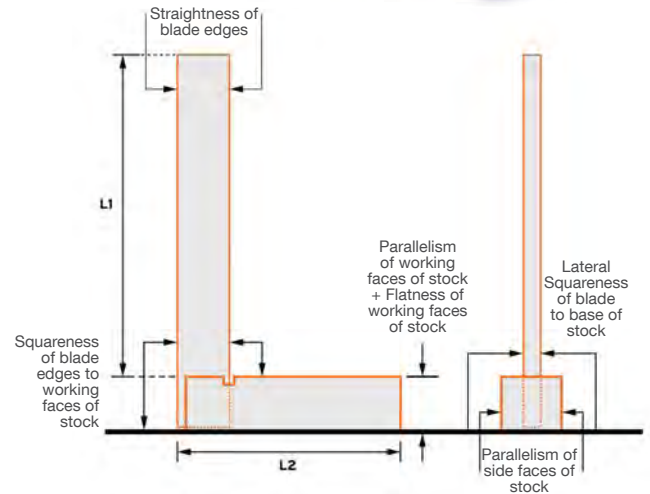

Technical Information

Part No.	Straightness of blade edges		Flatness of working faces of stock		Parallelism of working faces of stock		Parallelism of side faces of stock		Squariness of blade edges to working faces of stock		Lateral squariness of blade to base of stock	
	inch	microns	inch	microns	inch	microns	inch	microns	inch	microns	inch	microns
GZ-01000	0.00031	8	0.00016	4	0.0002	5	0.00098	25	0.00063	16	0.00492	125
GZ-01001	0.00031	8	0.00016	4	0.0002	5	0.00098	25	0.00063	16	0.00492	125
GZ-01002	0.00031	8	0.00023	6	0.0002	5	0.00098	25	0.00063	16	0.00984	250
GZ-01003	0.00031	8	0.00023	6	0.0002	5	0.00196	50	0.00063	16	0.00984	250
GZ-01004	0.00031	8	0.00031	8	0.00031	8	0.00196	50	0.00078	20	0.01476	375
GZ-01006	0.00047	12	0.00031	8	0.00031	8	0.00196	50	0.00094	24	0.01476	375
GZ-01007	0.00047	12	0.00031	8	0.00031	8	0.00196	50	0.00094	24	0.01476	375

ENGINEER'S PRECISION SQUARE SETS

- A selection of the most popular sizes available in a protective blow mould storage case

Part No.	Code	Description
GZ-01012	SS/A/2-4-6/ST	Engineer's Precision Square Set 3 Piece 50, 100, 150mm
GZ-01011	SS/A/2-3-4-6/ST	Engineer's Precision Square Set 4 Piece 50, 75, 100, 150mm



MACHINIST'S SQUARES

- Whilst ideal for everyday workshop use, these are also suitable for woodworking applications.
- Made from high grade steel with hardened blade, these squares have accurate right angles both on the inside and outside.
- Both the blade and stock are accurately ground which ensures straightness and parallelism.



Part No.	Code	Blade Length L1	Blade Length L2	Squareness of blade edges to working faces of stock (microns)
GZ-01100	SS/2	50mm	50mm	48
GZ-01101	SS/3	75mm	60mm	48
GZ-01102	SS/4	100mm	75mm	48
GZ-01103	SS/6	150mm	100mm	72
GZ-01104	SS/8	200mm	125mm	72
GZ-01106	SS/10	250mm	165mm	72
GZ-01107	SS/12	300mm	210mm	96

MACHINIST'S SQUARE SET

- Includes 50, 75, 100 & 150mm



Part No.	Code	Description
GZ-01110	SS/2-3-4-6/ST	Machinist's Square Set, 4 piece 50, 75, 100, 150mm

STRAIGHT EDGES

- Manufactured from high quality spring steel, Straight Edges are fully ground and hand scraped for a perfectly flat surface, making these an extremely accurate tool.
- Used for drawing & scribing straight lines, checking surfaces for straightness, setting up machines such as planers etc.
- Straight Edges have flat edges on both sides.



Straight Edge being used to check flatness of an engine block.

Part No.	Code	Dimensions	Flatness of Edges (Microns)	Parallelism of Faces (Microns)
GZ-02500	SE/12	300 x 36 x 8mm	12	24
GZ-02501	SE/18	450 x 36 x 8mm	12	24
GZ-02502	SE/24	600 x 36 x 8mm	17	33
GZ-02503	SE/36	900 x 61 x 10mm	21	40
GZ-02504	SE/48	1200 x 61 x 10mm	28	50
GZ-02505	SE/60	1500 x 80 x 10mm	28	50
GZ-02506	SE/72	1800 x 80 x 10mm	38	74

CENTRE SQUARE

- An extremely useful tool for the machinist on the lathe or the tool maker at the bench for locating centres of round stocks and parts quickly and easily. The Knife edge is made from Spring Steel and is hardened $40 \pm 5\text{HRC}$ and ground for extended life.
- 75mm length

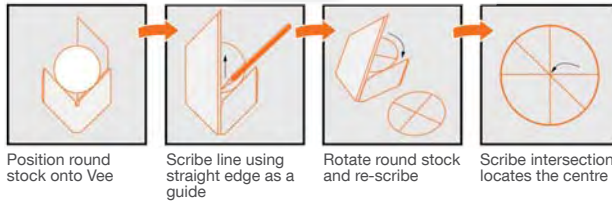

Part No.	Code	Description
GZ-03522	CS/2	Centre Square, 75mm

MACHINIST'S JACK

- Manufactured from high grade cast steel, the Machinist's Jack has a 1" adjustable screw and tilting swivel head.
- For use on drill presses, milling machines, planers etc. any place where levelling is necessary.
- Lifting capacity is approximately 454kg (1000 lbs).
- Base Diameter : 38.8mm
- Top Plate Diameter : 22.8mm
- Minimum Height : 80.4mm



Part No.	Description	Capacity	Height Adjustment
GZ-14100	MJ/01	454kg	25mm

MAGNETIC COMPASS

- An extremely versatile tool that can be used as an Angle Finder, Centre Locator & Levelling Gauge.
- Tool is designed to give accurate reading of angles for full 360° via an extremely sensitive & balanced needle.
- The protractor body is encased in cast aluminium shell with legs made from cast iron. The Vee bases have inbuilt magnets that exert magnetic pull both within the Vee & across the bottom surface of the legs of the Vee. This allows the tool to attach instantly to any ferrous surface – round or flat for accurate measurement of angles.
- The Vee bases are precision ground and the centre pin shows the middle point for locating centres on round objects. Can also be used for levelling work on workpieces.
- This tool has unlimited applications and can be used in:
 - Tool rooms & machine shops for determining angles on shapers, milling machines & grinders. For determining centre of round stocks, & for drilling operations.
 - Welding Shops
 - Construction & Maintenance sites
 - Auto & Truck shops, especially for checking angles of die lines
- Angle Accuracy: within $\pm 0.5^\circ$.



Locate centre on circumference at any angle to the ground



Check table alignment in the horizontal plane

Part No.	Code	Description
GZ-01690	MBP/01	Magnetic Compass

EDGE & CENTRE FINDERS

- Edge & Centre Finders are time saving positioning tools for use in jig boring, milling machines etc. These are used for accurately locating work edges, shoulders, grooves, centre points & scribed lines.
- Manufactured from precision ground tool steel, these are case hardened 45-48HRC.
- The diameter & concentricity are controlled to within 0.0002" (5 microns).



GZ-03501

GZ-03512

GZ-03500

GZ-03503

COMBINATION EDGE & CENTRE FINDER

One tool serves two purposes. It will find centres and also locate work edges



GZ-03506

DOUBLE EDGE FINDER



GZ-03507

Part No.	Code	Description	Shank
Combination Edge & Centre Finder			
GZ-03506	EF/6	Combination Edge & Centre Finder, 0.20" Tip	3/8"
Edge Finders			
GZ-03501	EF/2M	Edge Finder, End Style	10mm
GZ-03512	EF/13	Edge Finder, Middle Style	10mm
GZ-03500	EF/1	Edge Finder, End Style, 0.20" Tip	3/8"
GZ-03503	EF/4	Edge Finder, End Style, 0.20" Tip	1/2"
Double Edge Finder			
GZ-03507	EF/7	Double Edge Finder, End Style, 0.20" Tip	1/2"

ELECTRONIC & AUDIBLE EDGE FINDER

- Designed for 2D aligning of component reference surfaces & edges, determining bore centres with reference to the centre of the machine spindles.
- Industrial robust & non wearing design, with the body made from hardened steel & a spring loaded highly accurate steel ball.
- On contact between the spherical tip & the metal component, the unit lights up and triggers an audible alarm, thus identifying the point of reference.
- All functional parts are hardened & accurately ground.
- Reads off any electrically conductive metal.
- Comes complete with batteries.
- Concentricity controlled to within 0.0004" (10 microns)



Part No.	Code	Description	Shank
GZ-03537	EF/2D/AD/1	Electronic & Audible Edge Finder, 0.40" Ball	3/4"

CENTRE FINDER



- Centre Finder attachments with quick release chuck, clamped by a ball swivel joint which allows adjustment to any angular position.
- With needle point shank, working centres can be accurately located. Spring tension on the ball of the point allows guiding the point to true concentricity bringing perfect alignment between the work and machine spindle.
- Centre Finder with Ball Contact is useful in locating work by first bringing the ball contact against the work and then indexing it to the desired position relative to the spindle.
- Centre Finder with Disc Contact is particularly useful in locating work in confined areas such as slots or shallow holes. Diameter of Disc: 0.1".
- Centre Finder with Offset Indicator holder is useful for checking run out or concentricity and in checking straightness or alignment of flat surfaces.

Part No.	Code	Description
GZ-03520	WCF/WZ/6	Centre Finder, Chuck & 4 Attachments

TOOL MAKER'S VEE BLOCK & CLAMP SETS

- Manufactured from high grade tool steel fully hardened to 55-60 HRC.
- Manufactured and numbered in matched pairs, each pair has two 90° Vees of different capacities which are identical to the Vees of its matching block. The Vee's are ground central, parallel and square with the ends and sides.
- These Vee Blocks are very useful for holding work securely during drilling, milling and grinding operations and also in layout and inspection work. Each pair of Vee Blocks comes complete with a pair of rigid and robust clamps.
- Available in two types: Regular type and Non protruding clamp type. Top clamping design of the Non protruding clamp type allows the blocks to be used on the side faces in addition to the base.

Vee Blocks & Clamp Sets
- Regular



Vee Blocks & Clamp Sets -
Non Protuding Clamp Type

- Permissible Height difference between matched pairs
- Within 0.0002" (5 microns)
- Parallelism and Squareness of Vee grooves with respect to all surfaces
- Within 0.0003" (8 microns)
- Parallelism of opposite faces of Vee Blocks
- Within 0.0003" (8 microns)
- Squareness of adjacent exterior faces of Vee Blocks
- Within 0.0003" (8 microns)
- Flatness of Working Faces
- Within 0.0002" (5 microns)

Part No.	Code	Dimensions	Capacity
Vee Blocks & Clamps - Regular Type			
GZ-03000	VB/T/30	40 x 32 x 32mm	25mm
GZ-03001	VB/T/35	50 x 37 x 37mm	32mm
GZ-03004	VB/T/70	70 x 45 x 37mm	37mm
Vee Blocks & Clamps - Non Protuding Type			
GZ-03080	VB/SP/R/T/70	70 x 63 x 45mm	37mm

VEE BLOCKS - CAST IRON

- Made from close grained cast iron, these blocks are precisely ground and machined square and parallel.
- The Vee's are 90° centred in true.
- The blocks are manufactured and supplied in numbered pairs and come in handy for holding large jobs where clamping is not necessary.



Squareness and Parallelism of Vee Grooves with respect to base

- Within 0.0012" (30 microns)

Part No.	Code	Dimensions	Vee Width
GZ-03101	VB/C/4	100 x 40 x 65mm	56mm
GZ-03103	VB/C/6	150 x 62 x 88mm	78mm

FOR GROZ CRAMPS AND PARALLEL CLAMPS SEE PAGES 81 & 85



VEE BLOCK & CLAMP SETS

- Manufactured from high grade tool steel fully hardened to 55-60 HRC.
- The special design with 90° Vee angle provides a quick, accurate and positive means of holding workpieces for machining, grinding and in layout and inspection work.
- In addition to use on base, the Vee block can also be used on its side or end.
- The unit comes complete with a reversible swing away style clamp that clamps against almost any shape of product.
- The three tapped hole positions in the Vee block for the clamp allows the clamp to be positioned at either end or at the centre of the Vee block.
- Tapped holes on the Vee block end allow mounting the block perpendicular to the face plate. Each unit comes complete with the basic block, reversible clamp and 2 clamp screws.
- Also available in matched pairs with 2 block, 2 clamps and 4 screws.



- Parallelism and Squareness of Vee Grooves with respect to the base
- Within 0.0003" (8 microns)
- Matched Pair Tolerance
- Within 0.0002" (5 microns)



Versatile Vee Block allows reversal of clamp to facilitate clamping of jobs with a smaller diameter or irregular form.

Part No.	Code	Description	Dimensions	Capacity
GZ-03092	VB/SP/V/100S	Single	100 x 75 x 75mm	57mm
GZ-03093	VB/SP/V/100P	Matched Pair	100 x 75 x 75mm	57mm

ADJUSTABLE ANGLE BLOCK 0° - 60°

- Made from fully hardened (50-55 HRC) and ground tool steel, these precision Adjustable Angle Blocks are useful for most drilling, milling and set up jobs where a particular angle to a reference face is required.
- The block is fully adjustable from 0°-60° and can be set at any desired position by locking of the hex screw located in the base.
- Angle Accuracy : $\pm 1.0^\circ$.
- Squareness : 0.0004" (10 microns).



Part No.	Code	Angle	Dimensions
GZ-02100	PAB/01/A	0° - 60°	95 x 45 x 50mm

MAGNETIC VEE BLOCKS

- Designed for versatility and accuracy, these Vee Blocks are ideal for holding round or irregular shapes for scribing, grinding, measuring, machining and testing applications.
- All Vee's and faces can be energised or de energised simultaneously by turning the rotary action control knob. This feature enables the Vee Block to hold both itself and the work on any flat ferrous surface including a permanent magnetic chuck (without energising the chuck). Brass knob ensures no interference with the magnetic field.
- For applications requiring two Vee blocks matched and numbered pairs are available



Part No.	Code	Description	Dimensions	Capacity
GZ-02900	MVB/4S	Single	100 x 75 x 95MM	70mm
GZ-02901	MVB/4P	Matched pair	100 x 75 x 95MM	70mm

ADJUSTABLE VEE BLOCK SET

- Precision made tool performing all of the functions that would normally require usage of various shims, blocks or machinist's jacks. Ideal for inspecting shafts and parts with multiple diameters.
- Anvil height on the block is easily adjustable to support shafts, bars of varying diameters making for quick inspection without having to use centres.
- Anvil supports up to 450 kg.
- Vibration lock (position lock) prevents creeping.
- Wide angle Vee accepts 5mm to 125mm diameters.
- Top flats ground parallel to the base can hold wide, flat parts. Narrow flats may be held on a parallel across the top.
- Total Rise of Vee - 12mm. Dial graduated in increments of 0.001" (25 microns).
- Sold as a set of 2 blocks in matched pairs.



- Permissible height difference between matched pairs : Within 0.001" (25 microns)
- Flatness of base : Within 0.0002" (5 microns)



Adjustable Vee Block being used to check concentricity of different diameters on a stepped rod

Part No.	Code	Dimensions	Capacity
GZ-02930	AVB/1P	23 x 100 x 75mm	125mm

BALL BEARING VEE BLOCK & CLAMP SET

- High precision Ball Bearing Vee Blocks are used to inspect & detect out of round conditions, defects and lobes without damage to both the parts being checked and the Vee Block itself.
- Ideal for use where inspection set-ups are not otherwise possible using regular Vee Blocks. Design allows inspection of components from two angles by turning the spacer block 90°.
- Vee Block bases are made from cast iron and use hardened 60HRC wear resistant balls with sphericity controlled to within 0.00025" (0.6microns) on the small and medium sets and 0.0005" (1.27 microns) on the large set. Balls are finished to 0.2 microinches.
- Supplied in matched pairs, complete with two clamps and one test ball.
- Matched pairs are controlled to within $\pm 0.0002"$ (5 Microns)



Ball Bearing Vee Blocks with non marring balls being used to check the roundness of a stepped rod

Part No.	Code	Maximum Capacity Without Clamps	Clamping Capacity
GZ-02940	VB/BB/1-2	63mm	100kg

MARKING TOOLS

JENNY CALIPERS HERMAPHRODITE CALIPER

- Manufactured from high grade steel, the legs are exceptionally rugged and well finished. The leg that holds the adjustable point is offset. The locating lug is incorporated in the straight leg.
- These are very useful in layout work for locating and testing centres, laying off distances from an edge etc. Working faces hardened to 58 HRC.
- 150mm capacity



Lug provides additional support to the leg

A specific advantage of the Jenny Caliper is that it allows easy marking of arcs along the edge of workpiece



Part No.	Code	Description
GZ-01540	JC/6	Jenny Calipers, 150mm

WING COMPASS

- These rugged industrial grade compasses are manufactured from heavy gauge steel with a black powder coated finish.
- The tip is accurately ground. The heavy duty hinge and knurled nut help deliver a smooth action.
- Used for precisely scribing arcs and circles on projects and drawings.



Part No.	Code	Scribing Capacity
GZ-01550	WC/6	200mm
GZ-01551	WC/8	265mm

UNIVERSAL SURFACE GAUGES

A basic tool for machinists and toolmakers, the Universal Surface Gauge is used for accurately scribing lines, transferring measurements or probing surfaces in inspection work. Design incorporates:

- A fully hardened and ground base which serves as an accurate reference surface.
- A machined Vee groove in the base allows the gauge to be used conveniently on curved surfaces.
- A Vee groove at the front end allows the spindle to adjust to any angle above or below the base allowing it to be used as a height gauge and also as a depth gauge.
- Two retractable pins allow the gauge to be located against the edge of a surface plate or T-slot for linear work.
- A 6.34 mm hole in the spring loaded scriber holder allows a dial indicator to be attached conveniently making the gauge useful for checking flatness, parallelism, heights, depths etc.
- Grooves on the side of the base allow for comfortable grip.
- Well tapered scriber for better sighting while working. The scriber tip is hardened to 55-60 HRC.



Part No.	Code	Spindle Length
GZ-03200	SG/4-7	180mm
GZ-03201	SG/9-12	300mm

SCRIBERS

- A comprehensive line of steel body scribers for machinists, engravers, mechanics and craftsmen.
- Basic tool for scribing and marking. Scribers can be used on metal, glass, plastics and ceramics. Scriber points are hardened 55-60 HRC. Scribers are finely tapered permitting better sighting during work.



Part No.	Code	Description	Overall Length
GZ-03210	MS/7	Double End Scriber, Steel Body, Straight & 90 Deg Point	190mm
GZ-03211	MS/H/8	Double End Scriber, Steel Body, Straight & 90 Deg Point	230mm
GZ-03214	MS/P/3	Pocket Scriber, Steel Body	89mm
GZ-03217	MSCP/6	Double End Scriber, Steel Body, Point And Chisel End	170mm
GZ-03221	MS/MG/6	Pocket Scriber, Steel Body, Carbide Tip With Magnet	150mm

MEASURING TOOLS

SPRING CALIPERS & DIVIDERS

- Calipers are designed for taking comparative measurements and transferring the dimensions to a micrometer, precision rule etc.
- Dividers are used for marking out circles on steel or transferring measurement from master templates.
- Manufactured from high grade steel, calipers and dividers have a spring joint for precision settings. The legs pivot on a roller and are tensioned by bow spring. The fulcrum stud has a large bearing surface that prevents side deflection of legs.
- Divider points are hardened 50-55 HRC for increased wear resistance.



Part No.	Code	Arm Length
Spring Inside Calipers		
GZ-01401	ID/4	100mm
GZ-01402	ID/6	150mm
GZ-01403	ID/8	200mm
GZ-01404	ID/10	250mm
GZ-01405	ID/12	300mm
Spring Outside Calipers		
GZ-01411	OD/4	100mm
GZ-01412	OD/6	150mm
GZ-01413	OD/8	200mm
GZ-01414	OD/10	250mm
GZ-01415	OD/12	300mm
Spring Dividers		
GZ-01421	DD/4	100mm
GZ-01422	DD/6	150mm
GZ-01423	DD/8	200mm
GZ-01424	DD/10	250mm
GZ-01425	DD/12	300mm

SPRING CALIPERS & DIVIDERS - PREMIUM

- Precision made to exact standards throughout. Manufactured from high grade steel, the legs are machined to a smooth taper. Fulcrum stud has a large bearing surface preventing side deflection of legs. The finely machined solid nut runs smoothly to secure legs exactly to dimension.
- Divider points are hardened 50-55 HRC for increased wear resistance.



Spring Inside Calipers Spring Outside Calipers Spring Dividers

Part No.	Code	Arm Length
Spring Inside Calipers with Solid Nut		
GZ-01461	ID/SP/4	100mm
GZ-01462	ID/SP/6	150mm
GZ-01463	ID/SP/8	200mm
GZ-01464	ID/SP/10	250mm
GZ-01465	ID/SP/12	300mm
Spring Outside Calipers with Solid Nut		
GZ-01471	OD/SP/4	100mm
GZ-01472	OD/SP/6	150mm
GZ-01473	OD/SP/8	200mm
GZ-01474	OD/SP/10	250mm
GZ-01475	OD/SP/12	300mm
Spring Dividers with Solid Nut		
GZ-01481	DD/SP/4	100mm
GZ-01482	DD/SP/6	150mm
GZ-01483	DD/SP/8	200mm
GZ-01484	DD/SP/10	250mm
GZ-01485	DD/SP/12	300mm

SPRING CALIPERS & DIVIDERS SETS - PREMIUM

Each set includes a spring inside caliper, spring outside caliper and a spring divider



Part No.	Code	Description
GZ-01492	CD/SP/6/ST	Spring Calipers & Dividers Sets - Premium 3 Piece, 150mm
GZ-01493	CD/SP/8/ST	Spring Calipers & Dividers Sets - Premium 3 Piece, 200mm

DEGREE PROTRACTORS

- Manufactured from stainless steel, the Degree Protractor comes with a semi-circular or a rectangular head.
- The head has permanent deep etched graduations, 0° to 180° in opposite directions thus permitting reading an angle directly and also its supplement.
- The 150 mm blade has a graduation line on one end that permits accurate setting and reading of angles. The blade can be firmly set at the desired angle by means of a knurled nut.
- This is an ideal tool for machinists, draftsmen and mechanics for setting bevels, transferring angles, small squaring tasks, checking cutter clearances within limits etc.
- The rectangular head provides additional convenience as it incorporates 4 working edges.
- Angular Tolerance: 0.5°.

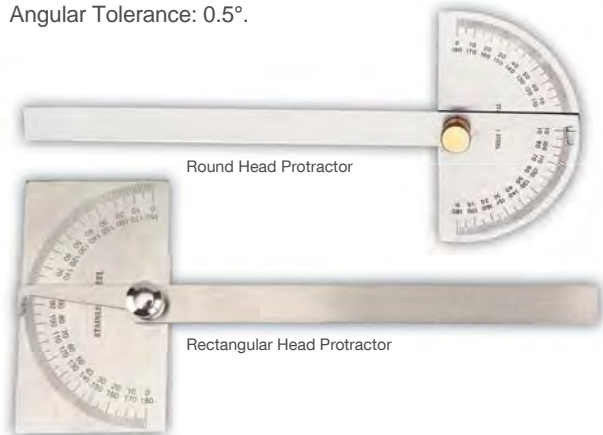

Part No.	Code	Head Shape	Blade Length
GZ-01220	DP/6	Round	150mm
GZ-01224	DP/R/6	Rectangular	150mm

DEPTH & ANGLE GAUGE

- The ability to measure depths and angles is combined in this versatile tool.
- The head is made from high grade steel and has a black finish. It is graduated both left and right to 15°, 30°, 45° and the rule can be set to any of these angles.
- A 150mm (6") steel rule is fitted to the head and can be locked in final position by a knurled nut for depth or angular measurements.
- 150mm length



Part No.	Code	Length
GZ-01214	DG/G	Depth And Angle Gauge, 150mm

DEPTH GAUGES WITH PROTRACTOR

- A versatile tool, the Depth Gauge with Protractor allows for measurement of both angles and depths.
- Manufactured from stainless steel, the protractor head has permanent deep etched graduations, 0°-180° in opposite directions, thus permitting reading an angle directly and also its supplement.
- Depths are measured by a 150mm (6") steel rule. It is graduated in imperial dimensions on one side and metric on the other and can be set at any desired angle for use as a protractor and lengthwise when used as a depth gauge. A knurled thumbnut locks the rule in the desired position.
- The gauge has a flat surface on the back of the head permitting laying the tool flat upon the work. The rectangular head provides additional convenience as it incorporates 4 working edges.
- Angular Tolerance : 0.5°.

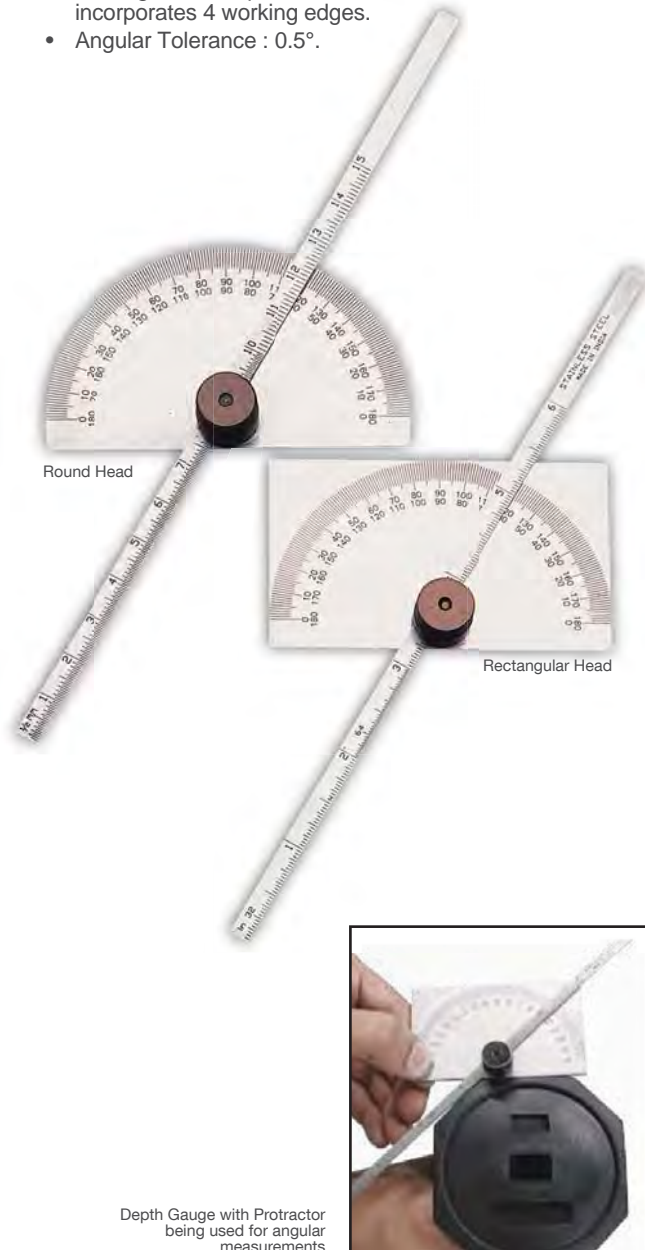

Part No.	Code	Head Shape	Blade Length
GZ-01221	PDG/6	Round	150mm
GZ-01225	PDG/R/6	Rectangular	150mm

MULTI-USE RULE & GAUGE

Can be used as:

- A Drill Point Gauge for checking 118° included angle drill points.
- A Protractor for measuring and laying out angles.
- A Centre Finder for locating centres on shafts and circles.
- A Circle Divider for dividing circles into sectors, polygons and polygrams (up to nine equal parts).
- Tap and Drill Table shows popular tap sizes and corresponding drills sizes for American National threads.

Manufactured from stainless steel, this multi-use tool comes complete with a 100mm (4") rule with permanently etched graduations in millimeters and 64th.

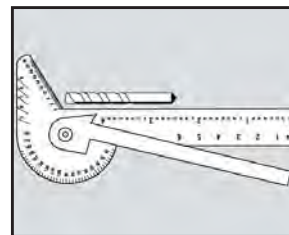

As a Drill Point Gauge

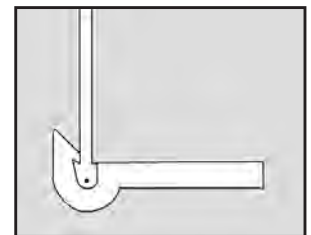

As a Square

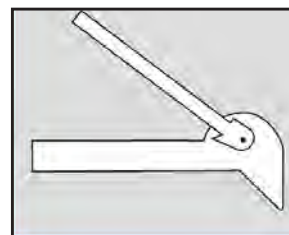

As a Protractor

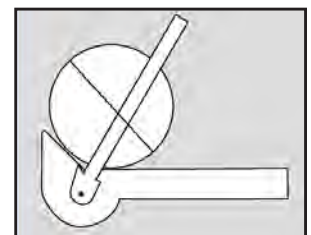

As a Centre Finder

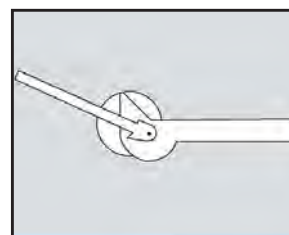

As a Circle Divider

Part No.	Code	Description
GZ-01240	RNG/4	Multi-Use Rule & Gauge 100mm

STEEL RULES

- Made from stainless steel, these rules have a polished finish with permanently engraved clear to read graduations.
- Available in two types:
 - Metric & Imperial Combined Rules
 - Metric Rules
- Metric & Imperial combined rules: These rules are graduated in metric dimensions on one edge and imperial on the other. Imperial dimensions are in 1/16th, 1/32nd & 1/64ths. Metric dimensions are in 0.5mm & 1mm. Reverse side of the rule has a permanently engraved metric to imperial conversion table.
- Metric rules : Graduated in metric dimensions 0.5mm & 1mm on both edges.



Part No.	Code	Length
Imperial and Metric		
GZ-01330	SR/6	150mm / 6"
GZ-01331	SR/12	300mm / 12"
GZ-01332	SR/18	450mm / 18"
GZ-01333	SR/24	600mm / 24"
GZ-01334	SR/40	1000mm / 40"
Metric		
GZ-01340	SR/150	150mm
GZ-01341	SR/300	300mm
GZ-01342	SR/450	450mm
GZ-01343	SR/600	600mm
GZ-01344	SR/1000	1000mm

BORE GAUGE (TAPER GAUGE)

- Manufactured from stainless steel with permanently engraved graduations.
- Accurate taper throughout the length of the gauge makes it a convenient tool for measuring diameters of small holes, slots etc.
- With imperial graduations on one side & 1-15mm metric on the other, this is an ideal tool for die makers, machinists and on inspection floors.



Part No.	Code	Description
GZ-01200	BG/1-15	Bore Gauge

SHEET METAL & WIRE GAUGES

- Made from heavy gauge hardened stainless steel.
- Designed for measuring steel wire, hot & cold rolled steel sheet etc & check sizes from 0 to 36 gauge.
- The gauge has metric dimensions marked on one side and gauge markings on the other.
- Accuracy : within 100 microns.



Part No.	Code	Description
GZ-01213	WG/RD/3	Steel Metal & Wire Gauges

SCREW CUTTING GAUGE

- Manufactured from hardened and polished stainless steel, all gauge surfaces are accurately ground.
- It is most useful for checking tool angle while cutting threads in metal turning lathes. The angle on the thread cutting tool is checked on the V slots in the gauge.

Relief at the end of each slot enables proper seating of the cutting tool in the slot thus ensuring correct angle

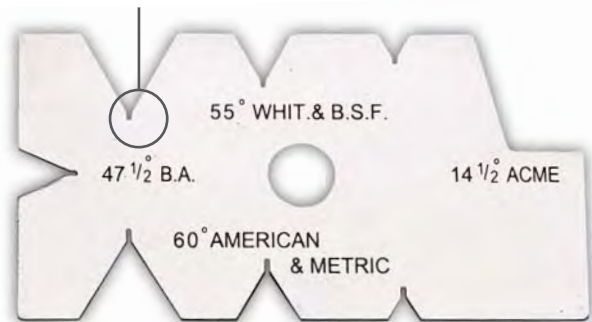

The gauge clearly indicates 55° for Whitworth and BSF Threads; 47-1/2° for BA Threads, 60° for Metric and American National Threads and 14-1/2° for Acme threads

Part No.	Code	Description
GZ-01223	SCG/4714	Screw Cutting Gauge

ENGINEER'S TOOL SETS

Each set of tools is fitted into a specially designed durable wallet with the contents detailed on the wallet.

6 PIECE SET



- Inside Caliper 4" (100mm) (GZ-01401)
- Outside Caliper 4" (100mm) (GZ-01411)
- Screw Cutting Gauge (GZ-01223)
- Steel Rule 6" (150 mm) (GZ-01330)
- Pocket Scriber 3-1/2" (89mm) (GZ-03214)
- Centre Punch 5/32" (4mm)

Part No.	Code	Description
GZ-03600	ETS/1/ST	Engineer's Tool Set, 6 Piece

7 PIECE SET



- Engineer's Precision Square 4" (100mm) (GZ-01002)
- Jenny Caliper 6" (150mm) (GZ-01540)
- Steel Rule 6" (150 mm) (GZ-01330)
- Double Ended Scriber 7-1/2" (190mm) (GZ-03210)
- Centre Punch (4mm)
- Adjustable Tap & Reamer Wrench 180mm
- Spring Divider 4" (100mm) (GZ-01421)

Part No.	Code	Description
GZ-03601	ETS/2/ST	Engineer's Tool Set, 7 Piece

CENTRE GAUGES

- Manufactured from stainless steel, these small flat gauges have angles of 55° and 60°.
- Very useful for grinding and setting thread cutting tools, these may also be used for checking the pitch of threads through the permanently deep etched graduations in 14ths, 20ths, 24ths and 32nds of an inch.
- These gauges meet the American National or US 60° and Whitworth or English 55° specifications.

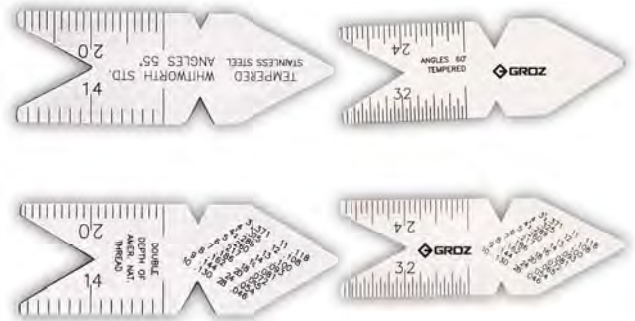

Part No.	Code	Angle
GZ-01210	CG/55	55°
GZ-01211	CG/60	60°

MEASURING TAPES

Top quality with ECC standard & reinforced tip



Part No.	Description
A8025M	8m Metric Measuring Tape
A8025MI	8m / 27ft Metric / Imperial Measuring Tape
A1025M	10m Metric Measuring Tape
A1025MI	10m / 30ft Metric / Imperial Measuring Tape

CARPENTER'S SQUARE

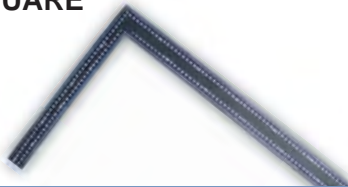

Part No.	Description
OS2060	600mm / 24" Metric / Imperial Black Carpenter Square

BALENO BUBBLE LEVEL

Quality German made vials



Part No.	Description
BMKL6024G2	600mm / 24" Magnetic Base
BAS003	Angle Setter Attaches To Baleno Level Rail

SMART TOOL

Digital levels



Part No.	Description
SLST600	600mm Smart Tool Digital Level
SLST1200	1200mm Smart Tool Digital Level
SLANFIND	Angle Finder (Module)

LUTRON DIGITAL TACHOMETER

Features

- Multi function, photo Tachometer (RPM) & contact tachometer (RPM, m/min, ft/min)
- Measuring range 0.5 to 100,000rpm
- The last value/max, value/min, value will be automatically stored in memory and can be obtained by the push of a button.
- High visibility 5 digit display
- Durable, long lasting components including strong, lightweight ABS-plastic housing



Specifications

- Photo tachometer range - 5 to 99,999RPM (0.1RPM increments up to 999.9RPM, 1RPM increments over 1000RPM)
- Contact tachometer range - 0.5 to 19,999RPM (0.1RPM increments up to 999.9RPM, 1RPM increments over 1000RPM)
- Surface speed range - 0.05 to 1999.9 m/min (0.01m/min increments up to 99.99m/min, 0.1m/min increments over 100m/min)
- Package Includes tachometer, carry case, reflective tape (600mm), cone RPM adaptor, funnel RPM adaptor, surface speed test wheel, user manual

Part No.	Description
DT2236	Lutron Digital Tachometer
DT2236TAPE	Replacement Reflective Tape To Suit DT2236

LUTRON DIGITAL SOUND LEVEL METER

Features

- Time weighting (fast & slow) dynamic characteristic modes
- Maximum Hold Function - Stores the maximum value read
- Durable, long lasting components including strong, lightweight ABS-plastic housing, assures maintenance free performance



Specifications

- 35 - 130dB range, 0.1dB increments
- Comes complete with Carry Case

Part No.	Description
SL4001	35 - 130 Decibel Digital Sound Level Meter

Magnetic Base Drilling Machines

Cutting Tools

Clamps

Engineer's Tools

Sharpening Machines

Metal Cutting Saws

Drilling Machines

Bevelling Machines & Welding Carriages

Punches & Shears

Grinding Machines

Fans & Ventilators

Workshop Storage

M7 Airtools

NPK Airtools

Pneumatic Products

PRECISION MEASURING TOOLS

OUTSIDE MICROMETERS

- Ratchet stop
- Enamel frame
- Carbide anvil with 0.000024" (0.6 micron) flatness
- Accuracy : 4 micron (0.00015")
- Resolution : 0.01mm
- Ratchet thimble
- Supplied with master for periodic calibration (except 0 - 25mm & 0 - 1")
- Supplied in moulded plastic case



Part No.	Code	Range
GZ-16104	MM/0-25	0 - 25mm
GZ-16105	MM/25-50	25 - 50mm
GZ-16106	MM/50-75	50 - 75mm
GZ-16107	MM/75-100	75 - 100mm
GZ-16108	MM/100-125	100 - 125mm
GZ-16109	MM/125-150	125 - 150mm
GZ-16112	MM/0-1	0 - 1"
GZ-16113	MM/1-2	1 - 2"
GZ-16114	MM/2-3	2 - 3"
GZ-16115	MM/3-4	3 - 4"
GZ-16116	MM/4-5	4 - 5"
GZ-16117	MM/5-6	5 - 6"

OUTSIDE MICROMETER SETS

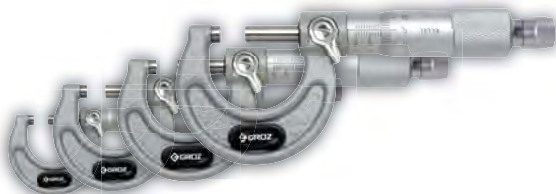

Part No.	Description
GZ-16110	4 Piece Metric Set, Plastic Case, 0 - 25mm, 25 - 50mm, 50 - 75mm & 75 - 100mm
GZ-16111	6 Piece Metric Set, Wooden Case, 0 - 25mm, 25 - 50mm, 50 - 75mm, 75 - 100mm, 100 - 125mm & 125mm - 150mm
GZ-16118	4 Piece Imperial Set, Plastic Case, 0 - 1", 1 - 2", 2 - 3" & 3 - 4"
GZ-16119	6 Piece Imperial Set, Wooden Case, 0 - 1", 1 - 2", 2 - 3", 3 - 4", 4 - 5" & 5 - 6"

IP54 DIGITAL MICROMETERS

- IP54 rated enclosure - Limited protection against dust ingress and protection against splash water
- Friction thimble
- Chrome plated frame with heat shield
- Metric and imperial digital readout on LCD screen
- Carbide anvil for added durability with 0.6 micron (0.000024") flatness
- Resolution : 0.001 mm (0.00005")
- Supplied with master for periodic calibration
- Supplied in moulded plastic case



Part No.	Code	Range
GZ-16122	MMED/1	0 - 25mm (0 - 1")
GZ-16123	MMED/2	25 - 50mm (1 - 2") Supplied With Master

IP65 DIGITAL OUTSIDE MICROMETER

- IP65 rated enclosure - Totally protected against dust ingress and protection against splash water
- Ratchet thimble
- Chrome plated frame with heat shield
- Metric and imperial digital readout on LCD screen
- Carbide anvil for added durability with 0.6 micron (0.000024") flatness
- Resolution : 0.001 mm (0.00005")
- Supplied in moulded plastic case



Part No.	Code	Range
GZ-16124	MMED/1/65	0 - 25mm (0 - 1")

VERNIER CALIPERS

- Metric & Imperial
- Stainless steel rule
- Convenient to use thumb screw locking mechanism
- Suitable for inside, outside, depth & step measurements
- Lower resolution : 0.02mm
- 300mm caliper is supplied in wooden case



Part No.	Code	Range	Jaw Length	Accuracy
GZ-16043	VNC/6	0 - 150mm (0 - 6")	40mm	20 micron
GZ-16044	VNC/8	0 - 200mm (0 - 8")	50mm	30 micron
GZ-16045	VNC/12	0 - 300mm (0 - 12")	64mm	40 micron

DIAL CALIPERS

- Stainless steel rule with dual pinion movement
- Convenient to use thumb screw locking mechanism & free wheeling thumb roller
- Suitable for inside, outside & depth measurements
- White face
- Resolution : 0.02mm
- Range per revolution : 2mm



Part No.	Code	Range	Accuracy
GZ-16062	DLC/150	0 - 150mm	20 micron
GZ-16063	DLC/200	0 - 200mm	30 micron
GZ-16064	DLC/300	0 - 300mm	40 micron

DEPTH BASE ATTACHMENT FOR CALIPER

- For use with all the calipers on this page



Part No.	Code	Base
GZ-16027	DBA/3	75mm (3")

DIGITAL CALIPERS

- Metric & imperial readout
- Hardened stainless steel design delivers accurate readings of inside, outside & step depth measurements
- Zinc die cast display chamber with hold down screw locking mechanism
- Graduation : 1mm intervals (1/10")
- Resolution : 0.01mm (0.0005")
- Accuracy : 20 micron (0.00079")
- Comes with SR44 battery



Part No.	Code	Range
GZ-16023	EDC/6	0 - 150mm (0 - 6")
GZ-16024	EDC/8	0 - 200mm (0 - 8")
GZ-16025	EDC/12	0 - 300mm (0 - 12")

IP67 DIGITAL CALIPER

- IP67 rated enclosure - Protection against coolants, dirt, chips and temporary water submersion
- Metric & imperial readout
- Hardened stainless steel design delivers accurate readings of inside, outside and depth measurements
- Auto ON / OFF feature which preserves battery life
- Zinc die cast display chamber with hold down screw locking mechanism
- Absolute and incremental measurements
- Graduation : 0 - 150mm in 1mm intervals & 0-6" in 1/10" intervals
- Resolution : 0.01mm (0.0005")
- includes 3V lithium battery



Part No.	Code	Range
GZ-16026	EDC/6/67	0 - 150mm (0 - 6")

VERNIER CALIPERS

- Metric and imperial measurements
- Manufactured from hardened stainless steel
- Convenient thumb screw locking mechanism
- Suitable for inside, outside, depth and step measurements
- Durable plastic storage case
- Graduation: 1mm intervals
- Lower resolution: 0.02mm



Part No.	Length	Accuracy	Internal Jaw Length	External Jaw Length
TM610-015	150mm	+/- 0.03mm	17mm	40mm
TM610-020	200mm	+/- 0.03mm	19mm	50mm
TM610-030	300mm	+/- 0.04mm	20mm	60mm

OUTSIDE MICROMETER

- Enamelled frame
- Ratchet stop and locking screw
- Carbide tipped measuring faces
- Ratchet thimble
- Durable plastic storage case
- Range: 0 - 25mm
- Graduation: 0.01mm
- Accuracy: +/- 0.04mm
- Jaw reach: 29mm



Part No.	Description
TM610-525	Outside Micrometer

DIGITAL VERNIER CALIPERS

- Large easy to read dual mode LCD screen (metric/imperial)
- Manufactured from hardened stainless steel
- Suitable for inside, outside, depth and step measurements
- Auto off feature
- Zero setting at any position
- Durable plastic storage case
- Graduation: 1mm intervals
- Resolution: 0.01mm (0.0005")
- Battery included



Part No.	Length	Accuracy	Internal Jaw Length	External Jaw Length
TM610-115	150mm	+/- 0.03mm	16mm	40mm
TM610-220	200mm	+/- 0.03mm	19mm	50mm
TM610-330	300mm	+/- 0.03mm	22mm	60mm

DIGITAL OUTSIDE MICROMETER

- Enamelled frame
- Carbide tipped measuring faces
- Ratchet stop and locking screw
- Dual mode digital display (metric/imperial)
- Auto off feature
- Durable plastic storage case
- Range: 0 - 25mm
- Graduation: 0.001mm (0.00005")
- Accuracy: +/- 0.04mm
- Jaw reach: 23mm
- Battery included



Part No.	Description
TM610-625	Digital Outside Micrometer

DIGITAL DEPTH GAUGES

- Made from stainless steel with thumbscrew locking mechanism
- Metric & imperial readout
- Digital Resolution : 0.01mm (0.0005")
- Base Width : 100mm
- Supplied in moulded plastic case



Part No.	Code	Range	Accuracy
GZ-16090	DDG/6	0 - 150mm (0 - 6")	20 micron (0.008")
GZ-16091	DDG/8	0 - 200mm (0 - 8")	30 micron (0.0012")
GZ-16092	DDG/12	0 - 300mm (0 - 12")	40 micron (0.0016")

VERNIER DEPTH GAUGES

- Made from stainless steel with thumbscrew locking mechanism
- Metric & Imperial
- Extendable depth gauge
- Accuracy : $\pm 0.05\text{mm}$
- Resolution : 0.05mm
- Supplied in moulded plastic case



Part No.	Code	Range	Width of Base
GZ-16080	VDG/6	0 - 150mm (0 - 6")	100mm
GZ-16081	VDG/8	0 - 200mm (0 - 8")	100mm
GZ-16082	VDG/12	0 - 300mm (0 - 12")	100mm

DIGITAL HEIGHT GAUGES

- Single beam construction
- Used for measurements and transfer of heights, scribing and marking of work pieces and other measurements like run out, centre distance etc.
- Carbide tipped scriber with clamp
- Freewheel mechanism
- Metric & imperial readout
- Zero setting at any position
- Accuracy : 40 micron (0.0016")
- Resolution : 0.01mm (0.0005")
- Includes SR44 batteries



Part No.	Code	Height Range
GZ-01636	DHG/12	0 - 300mm (0 - 12")
GZ-01637	DHG/18	0 - 450mm (0 - 18")

DIAL INDICATORS

- Robust construction
- 8mm stem diameter for metric models
- 3/8" stem diameter for imperial models
- Supplied with Lug backs
- Dial reading 0 - 100
- Built to American Gauge Design specifications
- Graduation / resolution : 0.01mm on metric models & 0.001" on imperial models
- Accuracy : $\pm 0.03\text{mm}$ ($\pm 0.002"$)
- Range per revolution : 1mm (0.1")
- Each revolution is indicated by a revolution counter
- Tolerance marker provided
- White face dial



Part No.	Code	Needle Range	Dial Range	AGD type
GZ-16202	DLG/5	0 - 5mm	0 - 100	AGD1
GZ-16203	DLG/10	0 - 10mm	0 - 100	AGD2
GZ-16204	DLG/1-2	0 - 1/2"	0 - 100	AGD2
GZ-16205	DLG/0-1	0 - 1"	0 - 100	AGD2

DIGITAL INDICATORS

- Robust construction
- Metric & imperial readout
- Supplied with flat and lug Backs
- Suitable for absolute, tolerance, metric & imperial measurements
- 8mm stem diameter
- Auto ON / OFF feature to preserve battery life
- Tolerance measurement feature allows for the upper and lower tolerance for maximum and minimum
- Accuracy: 7.6 micron (0.0003")
- Includes CR2032 3V battery



Part No.	Code	Range	Resolution
GZ-16220	DGI/1	0 - 12.5mm (0 - 0.5")	0.01mm (0.0005")
GZ-16221	DGI/2	0 - 12.5mm (0 - 0.5")	0.001mm (0.00005")

DIAL TEST INDICATORS

- Highest quality mechanism
- Clear graduations
- 32mm dial diameter for metric models
- 1-1/4" dial diameter for inch models
- 8mm dovetail stem diameter for metric models
- 3/8" dovetail stem diameter for imperial models
- Accuracy : $\pm 0.013\text{mm}$ ($\pm 0.0005"$)



Part No.	Code	Dial Reading	Range	Increments
GZ-16240	DTI/40M	0 - 40 - 0	0.8mm	0.01mm
GZ-16241	DTI/100M	0 - 100 - 0	0.2mm	0.002mm
GZ-16242	DTI/150	0 - 150 - 0	0.03"	0.005"

MAGNETIC BASES HIGH POWER

- These magnetic bases equipped with powerful permanent magnets can be readily located on any ferrous surface and are ideal for all applications that require a magnetic pull of up to 60 kgf (130lbf).
- The base and one side are energised for attachment to flat surfaces. Vee groove in the base facilitates gripping on curved surfaces.
- Unique design allows Dial Indicator to be set at any required position and easily adjusted for use. The bases have a grey hammertone finish, base post and gauge holding rod are chrome plated.
- Dial Gauge not included

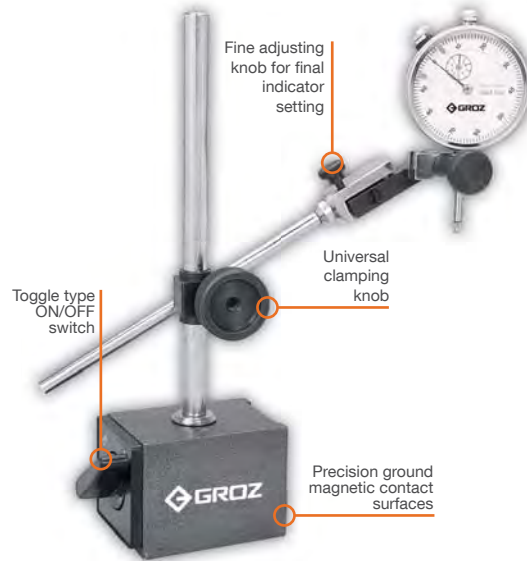

Part No.	Code	Description
GZ-03405	MB/31F	Magnetic base

ARTICULATING ARM WITH MAGNETIC BASE

- Accepts test indicators with dovetail clamping mechanism
- Arm has 3 articulating joints that can be locked with a single knob handle
- Dial gauges can be used with 3/8" or 8mm diameter stem
- Magnetic bases have ON/OFF switch
- Base has a vee groove that securely fastens to the ferrous work piece or machine table
- Working Angle : 150°
- Hole Diameter : 8mm (3/8")
- Slot : 6.5mm



Part No.	Code	Type	Arm Length	Base	Magnetic Power
GZ-03420	MB/30	I	180mm	30x40x35mm	30kg
GZ-03421	MB/80	II	280mm	50x60x55mm	80kg
GZ-03422	MB/80L	III	340mm	50x60x55mm	80kg

INTERNAL DIAL CALIPER GAUGES

- For checking internal bores, grooves and recesses
- Each revolution is indicated by a revolution counter
- Resolution : 0.025mm (0.001")
- Accuracy : $\pm 0.05\text{mm}$ ($\pm 0.002"$)
- Measuring tip diameter : 0.06"
- White dial face



Part No.	Code	Range
GZ-16070	IDC/1M	10 - 35mm
GZ-16071	IDC/1	0.375" - 1.375"

COMBINATION SQUARE SETS

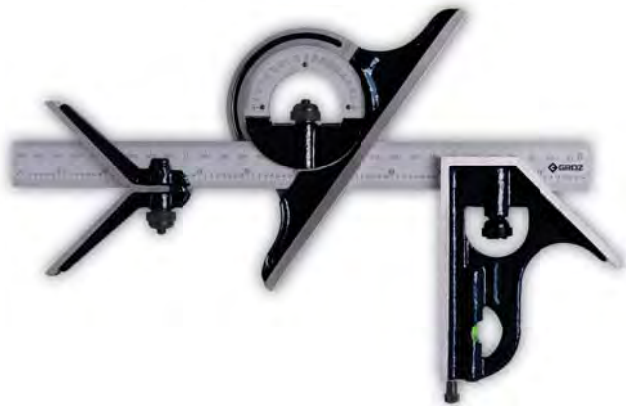

Part No.	Code	Description
GZ-01070	CSQ/12/4/ST	4 Piece Set, 12" (300mm) Blade Length
GZ-01080	RL/CSQ/12	12" (300mm) Rule To Suit GZ-01070
GZ-01081	CH/CSQ	Centre Head To Suit GZ-01070
GZ-01082	PH/CSQ	Protractor To Suit GZ-01070
GZ-01083	SH/CSQ	Square Head To Suit GZ-01070

METRIC THICKNESS GAUGES (FEELER GAUGES)

- Essential tool for checking valve tolerances, point gaps and other critical measurements
- Made from stainless steel
- Each leaf is marked with its thickness
- Locknut secures one or more leaves in position and each leaf is detachable if necessary



Part No.	Code	Range	Leaf Quantity	Leaf Width	Blade Length
GZ-01250	FLG/20/150	0.05 - 1mm	20	13mm	150mm
GZ-01251	FLG/13/100	0.05 - 1mm	13	13mm	100mm

RADIUS GAUGES

- Very useful for tool and diemakers, machinists, screw machine operators and pattern makers to lay out and check radii of tools, dies, and patterns
- Made of stainless steel
- Size is marked on each gauge leaf



Part No.	Code	Range	Leaf Quantity
GZ-01260	RDG/17/1-7	1 - 7mm	17 Pairs
GZ-01261	RDG/16/7.5-15	7.5 - 15mm	16 Pairs

MACHINE TOOL ACCESSORIES

DRILL CHUCK ARBORS

- Hardened and ground Drill Chuck Arbors, used to mount a drill chuck or any other tool which has a female taper onto a machine such as a drilling machine which has a female taper socket in its workhead.
- Manufactured from case hardened Hi-Tensile Steel (20 MnCr5/SAE 8620), all arbors are case hardened 54 - 58 HRC for increased resistance to wear.
- Precision grinding to very close tolerance with concentricity controlled to within 0.0004" (10 microns) and accurately gauged self locking tapers ensure close tolerance fit.



Part No.	Code	Description
GZ-07607	GAT/23	2MT - 3JT
GZ-07610	GAT/26	2MT - 6JT
GZ-07615	GAT/33	3MT - 3JT
GZ-07618	GAT/36	3MT - 6JT
GZ-07620	GAT/333	3MT - 33JT
GZ-07622	GAT/43	4MT - 3JT
GZ-07625	GAT/46	4MT - 6JT

DRILL CHUCKS



Part No.	Description	Mount Size	Capacity
DC11506-3	Keyed Drill Chuck	3/8" 24 Thread	13mm
DC11506-1	Keyed Drill Chuck	1/2" 20 Thread	13mm
DC11305-2	Keyed Drill Chuck	#3 JT	16mm
DC11306-1	Keyed Drill Chuck	#3 JT	19mm
DCK12305-2	Key-Less Drill Chuck	#3 JT	16mm
DCK12305-1	Key-Less Drill Chuck	#6 JT	16mm
DC11305-3	Keyed Drill Chuck	#B18	16mm
DC11506-2	Keyed Drill Chuck	#B18	13mm

REDUCTION SLEEVES (DRILL SLEEVES)

- Drill Sleeves are used to adapt smaller morse taper shank tools to larger machine spindles.
- The concentricity and taper angles are precisely controlled which allows perfect locking and concentric movement to the tool held.
- - A Grade - (Hardened and Ground) Manufactured from case hardened Hi Tensile steel (20 MnCr5/SAE 8620), these are fully hardened and are ground on the inside and outside.
- Permanent marking of size on the tang ensures convenience in use.
- Sleeve Type : A Grade
- Material : Case Hardened Steel
- Surface Finish of External Taper : Ground
- Surface Finish of Internal Taper : Ground
- Body Hardness : 54 - 58 HRC
- Tang Hardness : 54 - 58 HRC



Part No.	Code	Description
GZ-08420	DSA/2-1	2 - 1MT
GZ-08421	DSA/3-1	3 - 1MT
GZ-08423	DSA/3-2	3 - 2MT
GZ-08422	DSA/4-1	4 - 1MT
GZ-08424	DSA/4-2	4 - 2MT
GZ-08426	DSA/4-3	4 - 3MT
GZ-08432	DSA/5-1	5 - 1MT
GZ-08425	DSA/5-2	5 - 2MT
GZ-08427	DSA/5-3	5 - 3MT
GZ-08429	DSA/5-4	5 - 4MT

PIN VISE

- Pin vises are used for holding small taps, drills, reamers, scribers, wire, small files etc.
- These Pin Vises have special tool steel jaws that provide for a firm grip. A straight smooth section on the handle allows these vises to be held in machine chucks for machining operations. The handles have a hole extending through the entire length which allows holding wires of any length or diameter up to the full size of the tool. These are supplied as a set of 4.
- 0 - 4.5mm capacity



Part No.	Code	Description
GZ-35900	PV/1-4/ST	Pine Vise, 0 - 4.5mm Capacity

DRILL DRIFT KEYS



- Drop forged from specially drawn medium carbon steel, these Drift keys are accurately hardened for increased resistance to wear.
- Used for conveniently removing taper shank drills and reamers from sleeves and sockets, these are blackened and have a premium shot blast finish with permanent marking of size for easy identification.

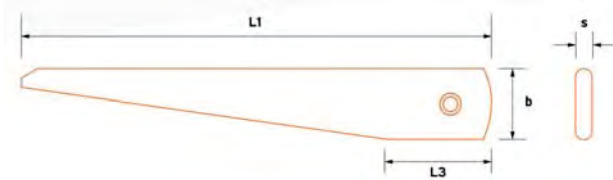

Part No.	Code	Fits Following Morse Taper	L1 (mm)	L3 (mm)	b (mm)	s (mm)
GZ-08601	DK/1-2	MT1 & MT2	140	25	20	5
GZ-08602	DK/0-3	MT3	190	40	25	7
GZ-08603	DK/0-4	MT4	225	40	30	10
GZ-08605	DK/5-6	MT5 & MT6	265	56	35	15

LATHE CENTRES (DEAD CENTRES)

- Manufactured from high quality carbon steel, solid construction and no moving parts. Fully hardened for increased resistance to wear. Hardness of tip 60 - 63 HRC, these centres are accurately ground and have a TIR of $\pm 0.0001''$ (± 2.5 microns).
- Tungsten Carbide Tip for increased durability, requiring less down time for regrinding.

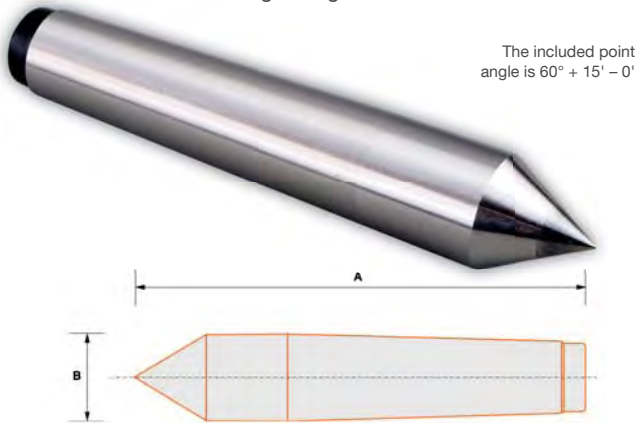

Part No.	Code	Morse Taper	A (mm)	B (mm)
GZ-11101	DCT/2	MT 2	100	18
GZ-11102	DCT/3	MT 3	125	24.1
GZ-11103	DCT/4	MT 4	160	31.6

KNURLING TOOL HOLDERS



The rigid and robust construction of the range of knurling tool holders makes them ideal for countless knurling applications. These are available in 3 types:

1. Knurling Tool Holders — 3 pairs
The revolving head is fitted with standard left and right pattern knurls in fine, medium and coarse pitch. Any pair can be brought to bear on the workpiece, thus 3 different knurling patterns are obtainable without changing the tool.
2. Knurling Tool Holder — 1 pair
A two knurl holder ideal for small knurling applications, it has a self adjusting pivot head which ensures that the knurl finds the centre line of the work exactly. It comes complete with one right and one left hand knurl.
3. Knurling Tool Holder — 1 Knurl
Single knurl holders, these are useful for light duty applications. They come complete with one straight knurl.

Part No.	Code	Knurl Dimension	Holder Size
Knurling Tool Holder - 3 Pairs			
GZ-11700	KT/6-1	19 x 9.5 x 6.35mm	190 x 35 x 16mm
GZ-11701	KT/6-2	19 x 9.5 x 6.35mm	165 x 28 x 13mm
GZ-11702	KT/6-3	16 x 8.0 x 5.5mm	142 x 22 x 10mm
Knurling Tool Holder - 1 Pair			
GZ-11814	KT/2-5	19 x 9.5 x 6.54mm	114 x 13 x 13mm
Knurling Tool Holder - 1 Knurl			
GZ-11800	KT/0-1	19 x 6.34 x 6.35mm	100 x 13 x 13mm

PIN CHUCK SET

- The Pin Chuck is a very useful reducing chuck used for holding drills too small to be held by a regular chuck. It is gripped in the larger chuck already on the machine by means of the back shank.
- Supplied with three interchangeable collets for holding small drills in varying sizes.
- 0 - 2.5mm capacity



Part No.	Code	Description
GZ-08800	PCH/1-3	Pin Chuck Set, 0 - 2.5mm Capacity, Include 3 Collets

MACHINE VISES - PRECISION

ROTARY HEAD VISE

- High Precision Milling Machine Vise with a rotary fixed head.
- The rotary head has 4 faces each with a different jaw option: Plain, Vertical V, Horizontal V & Prismatic.
- Rotary head design eliminates the possibility of any inaccuracy, which may occur when jaws are replaced.
- Jaws can be changed by simple rotation of the Rotary Head and fixed in position using 2 hex bolts.
- Manufactured from close grained hi-tensile cast iron, the vise body has a premium polychromatic finish.
- Vise jaws are made from fully hardened (55±3 HRC) and ground tool steel.
- Use of high tensile grade 10.8 fasteners provides greater strength and rigidity. The 360° swivel base allows the vise to be set at any angle along the vertical axis.



Part No.	Code	Jaw Width	Jaw Opening	Jaw Depth	Net Wt.
GZ-35051	RHV/100	100mm	100mm	37mm	20kg

MILLING MACHINE VISES SUPER PRECISION

- Manufactured from close grained hi-tensile cast iron, the vise body has a premium polychromatic finish which is scratch and rust resistant.
- Vise jaws made from fully hardened and ground tool steel allow the workpiece to be held dead square without use of any packing. This not only improves efficiency and life of jaws but also helps reduce strain on vise body.
- Usage of high tensile grade 10.8 fasteners provides greater strength and rigidity. The 360° swivel base allows the vise to be set at any angle along the vertical axis. Vise base has a milled slot which helps in accurate location of the vise on the machine table using rectangular locating nuts.
- "Hold Down" slots provide secure clamping of the vise on the machine table.

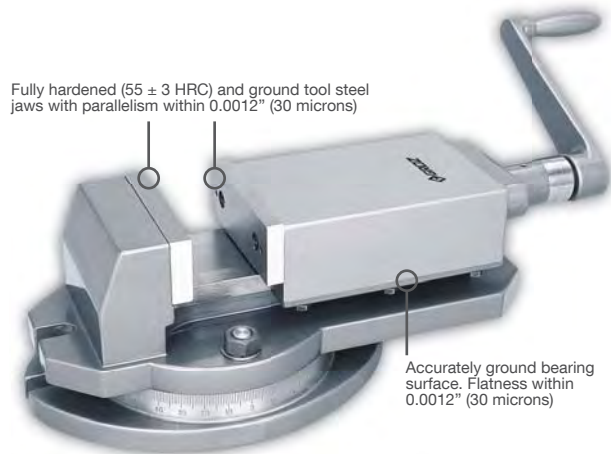

Milling machine vise being used to hold a job for milling operation.



Part No.	Code	Jaw Width	Jaw Opening	Jaw Depth	Net Wt.
GZ-35011	MMV/SP/100	100mm	100mm	38mm	17.4kg
GZ-35012	MMV/SP/150	150mm	150mm	45mm	38.8kg

ANGULAR MACHINE VISES SUPER PRECISION

- Angular adjustment is achieved via the angular slide that can be set to any desired angle 45° on either side. Additionally the fully graduated 360° swivel base allows the vise to be set at any angle along the vertical axis.
- These vises are manufactured from close grained hi-tensile seasoned cast iron with fully hardened and ground tool steel jaws.
- Ergonomically designed all steel handle allows for stress free operation. Assembled on the spindle crank with a spring loaded mechanism providing positive grip.
- Use of hi-tensile grade 10.8 fasteners provides strength and rigidity to these vises.
- Relief in clamp seat ensures complete surface contact as against a line contact between the "Hold Down" clamp and movable slide, thereby providing firm locking at any desired angle.
- A milled slot in the vise base helps in accurate location of the vise on the machine table using rectangular locating nuts.
- "Hold Down" slots provide secure clamping of the vise on the machine table.

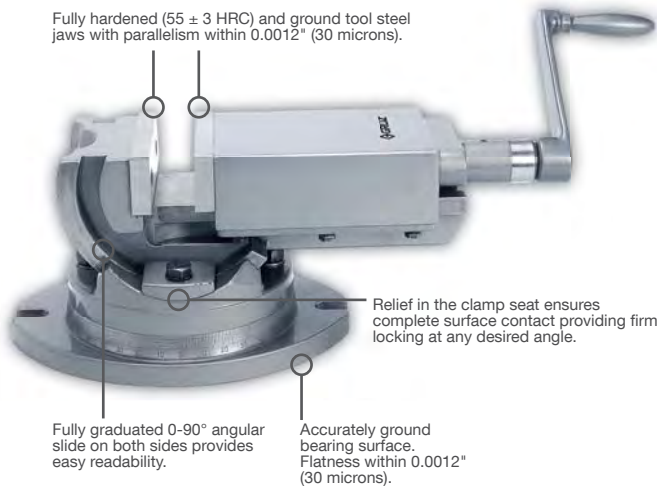

Part No.	Code	Jaw Width	Jaw Opening	Jaw Depth	Net Wt.
GZ-35002	AMV/SP/100	100mm	100mm	38mm	17.0kg
GZ-35004	AMV/SP/150	150mm	150mm	45mm	42.8kg

THREE WAY TILTING VISES SUPER PRECISION

- Tilting vises providing 3 axis settings of the workpiece in special milling, drilling, grinding, shaping and jig boring applications.
- Vises have 2 angular slides which allow the work piece to be set at any desired angle - 45° tilting range on either side and 90° vertical indexing. The 360° swivel base further allows rotation along the vertical axis.
- Manufactured from close grained hi-tensile cast iron with fully hardened and ground tool steel jaws. The vises have a premium polychromatic finish.
- Ergonomically designed all steel handle allows for stress free operation. Assembled on the spindle crank with a spring loaded mechanism providing positive grip.
- Use of hi-tensile grade 10.8 fasteners provides strength and rigidity to these vises.
- Relief in clamp seat ensures complete surface contact as against a line contact between the "Hold Down" clamp and movable slide, thereby providing firm locking at any desired angle.
- A milled slot in the vise base allows for accurate location of the vise on the machine table using rectangular locating nuts.
- "Hold Down" slots provide secure clamping of the vise on the work table.

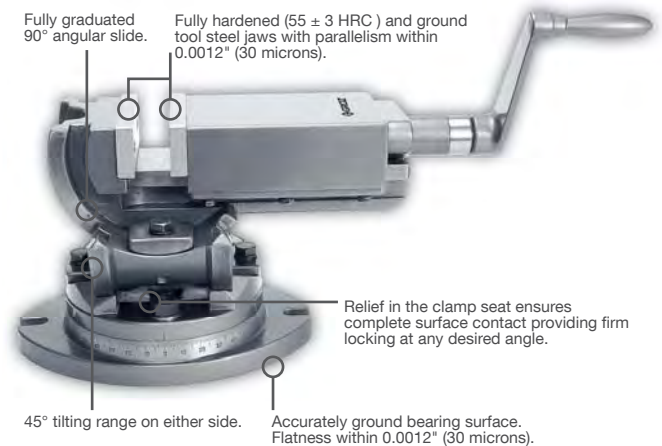

Part No.	Code	Jaw Width	Jaw Opening	Jaw Depth	Net Wt.
GZ-35022	TLT/SP/100	100mm	100mm	38mm	20.5kg
GZ-35027	TLT/SP/150	150mm	150mm	45mm	54.0kg

UNIVERSAL VISES SUPER PRECISION

- The most versatile of all machine vises with all degrees of freedom, the Universal Vise allows the work piece to be set at any desired angle.
- Low height construction makes these useful on even the most complicated applications.
- The vise has one fixed horizontal axis which allows the workpiece to be rotated at any angle. Fully graduated 360° swivel base allows complete rotation along the vertical axis. The third angular slide with a moving axis allows for any setting in the 3D plane.
- Manufactured from close grained hi-tensile cast iron with fully hardened and ground tool steel jaws. Premium polychromatic finish.
- Ergonomically designed all steel handle allows for stress free operation. It is assembled on the spindle crank with a spring loaded mechanism providing positive grip.
- Use of hi-tensile grade 10.8 fasteners provides strength and rigidity to these vises.
- A milled slot in the vise base allows for accurate location of the vise on the machine table using rectangular locating nuts.
- "Hold Down" slots provide secure clamping of the vise on the work table.

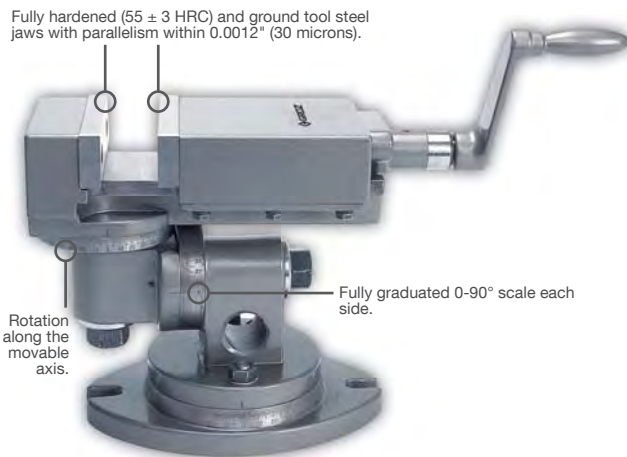

Rotation along the swivel base. Rotation along the movable axis parallel to the axis of the swivel base. Rotation along the axis perpendicular to the axis of the swivel base.



A combination of settings along the 3 axes produces the desired compound angle.

A typical case of the Universal vise set perpendicular to the base by rotation along the movable scale.

Part No.	Code	Jaw Width	Jaw Opening	Jaw Depth	Net Wt.
GZ-35031	UV/SP/100	100mm	100mm	32mm	13.4kg

SELF CENTRING VISES SUPER PRECISION

- The Self Centring Vise allows for accurate centring of jobs, automatically. The vise is especially useful in applications where the same operation is to be performed on workpieces of varying sizes.
- The special design allows accurate setting up of jobs with only a single machine setting. Centric clamping is particularly useful in milling, slot and groove cutting of all kinds.
- Manufactured from hi-tensile cast iron with fully hardened and ground tool steel jaws, the vise has opposite threads for quick and accurate centring.
- Fully graduated 360° swivel base allows the vise to be set at any angle along the vertical axis.
- A milled slot in the vise base allows for accurate location of the vise on the machine table using rectangular locating nuts.
- "Hold Down" slots provide secure clamping of the vise on the work table.

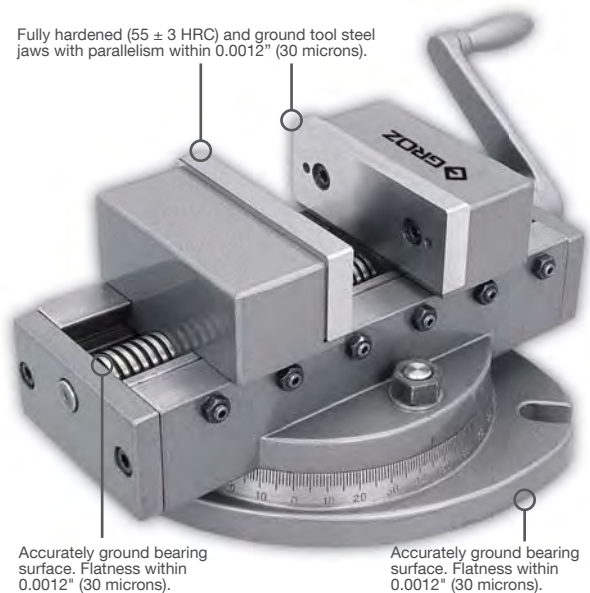

Self Centring Vise being used to mill key ways in the centre of the casting.



Part No.	Code	Jaw Width	Jaw Opening	Jaw Depth	Net Wt.
GZ-35040	SCV/SP/100	100mm	100mm	38mm	14.3kg
GZ-35045	SCV/SP/150	150mm	150mm	45mm	36.0kg

PREMIUM DRILL PRESS VISES

UNIVERSAL VISES

UNIGRIP

- Manufactured from graded cast iron, these vises have a precision ground base and vise bed for smooth lateral movement of the movable jaw.
- Longitudinal and transversal prisms in the fixed jaw allow for firm gripping of round jobs of different sizes both horizontally and vertically. Special seat in jaws facilitates retaining of flat work pieces.
- Vises are equipped with a convenient unigrip mechanism. Spindle moves inside the hollow hand grip allowing the vise to be used at a location away from the table edge.

3 WAY DRILL PRESS VISE

- This vise is also available with 3 mounting options via 2 additional precisely ground surfaces: end face and side face. This allows for drilling along all axes with a single setting of the job and holding of long workpieces which are cumbersome and difficult to manage in regular vises.



HEAVY DUTY DRILL PRESS VISES

- These Heavy Duty Drill Press Vises are specially designed for use by professionals who require a heavy accurate vise
- Manufactured from close grained cast iron, this vise offers a ground vise bed for smooth & consistent jaw movement
- Jaws are hardened & ground with cross patterned 90° V-grooves in the stationary jaw facilitating holding of round jobs both horizontally & vertically
- Rugged design makes these vises perfect for even the most difficult of drilling, tapping & reaming operations



Part No.	Code	Jaw Width	Jaw Opening	Jaw Depth	Net Weight
GZ-35102	DPV/60	63mm	70mm	25mm	2.4kg
GZ-35100	DPV/80	80mm	88mm	28mm	4.0kg
GZ-35101	DPV/100	100mm	100mm	35mm	7.7kg
GZ-35103	DPV/120	120mm	150mm	42mm	13.5kg
GZ-35104	DPV/150	150mm	170mm	50mm	22.5kg

Part No.	Code	Jaw Width	Jaw Opening	Jaw Depth
Drill Press Vise - Unigrip				
GZ-35120	DPV/UG/75	80mm	75mm	30mm
GZ-35121	DPV/UG/100	100mm	92mm	30mm
GZ-35122	DPV/UG/125	120mm	110mm	35mm
3 Way Drill Press Vise - Unigrip				
GZ-35125	DPV/UG/3/100	100mm	88mm	30mm

GENERAL PURPOSE DRILL PRESS VISES

STANDARD DRILL PRESS VISES

- Cast Iron Body
- Machined Steel Jaws
- Great For Machine Shops, Fabrication Workshops & Tool Rooms



Part No.	Jaw Width	Jaw Height	Capacity	Weight
VDP078	78mm	19mm	78mm	2.2kg
VDP102	102mm	21mm	105mm	3.2kg
VDP150	150mm	28mm	150mm	7.2kg

HEAVY DUTY DRILL PRESS VISES



Part No.	Jaw Width	Jaw Height	Capacity	Weight
VDPL100	100mm	30mm	92mm	6.75kg
VDPL155	150mm	36mm	140mm	13kg

DRILL PRESS CLAMP KITS

- 52 Piece
- 1/2" UNC Thread



Part No.	Includes
KKCLAMPKIT-9/16	9/16 T Slot, 1/2 UNC Thread 6 x T-Slot Nuts, 4 x Collarnuts Step Blocks 4 x 30mm, 4 x 46mm, 4 x 96mm Step Clamps 2 x 65mm, 2 x 100mm, 2 x 145mm Studs 4 x 75, 4 x 100, 4 x 125, 4 x 150, 4 x 175, 4 x 200mm
KKCLAMPKIT-5/8	5/8 T Slot, 1/2 UNC Thread 6 x T-Slot Nuts, 4 x Collarnuts Step Blocks 4 x 30mm, 4 x 46mm, 4 x 96mm Step Clamps 2 x 65mm, 2 x 100mm, 2 x 145mm Studs 4 x 75, 4 x 100, 4 x 125, 4 x 150, 4 x 175, 4 x 200mm

BENCH VISES

CAST IRON MECHANIC'S BENCH VISES

- Groz manufactures a comprehensive range of mechanic's vises useful for all medium to heavy duty applications. Manufactured from high quality grey iron castings - a very strong material with excellent shock absorbing capacity and immense strength under compression, these rigid & robust vises machined to close tolerances, are designed for smooth operation and reliability.
- The front jaw beam with machined construction fully encloses the vise spindle protecting the threads from contaminants and damage. The long unbreakable malleable iron nut securely locked in the body ensures maximum thread surface contact and constant alignment between body and the sliding jaw. Jaws are hardened 45 ± 5 HRC. Perfect alignment of main screw and nut reduces wear and gives long trouble free service. Vises have an attractive blue finish with main screw and handle plated. The anvil has a ground finish.
- A common sight in almost all workshops and garages, these are available with a fixed base for regular usage or a swivel base that allows rotation through 360° with firm locking at any position. The swivel base allows the vise to be used in confined spaces or where the angle of the vise has to be adjusted to accept work of varying lengths. The swivel base can be easily removed and the vise converted back to a regular fixed base vise.



Fixed Base Vise



Swivel Base Vise

Part No.	Code	Jaw Width	Jaw Opening
Fixed Base Vises			
GZ-35401	BV/F/100	100mm	125mm
GZ-35402	BV/F/125	125mm	150mm
GZ-35403	BV/F/150	150mm	175mm
GZ-35404	BV/F/200	200mm	200mm
Swivel Base To Suit Professional Mechanics Bench Vises			
GZ-35421	SWB/100	To Suit GZ-35401	
GZ-35422	SWB/125	To Suit GZ-35402	
GZ-35423	SWB/150	To Suit GZ-35403	
GZ-35424	SWB/200	To Suit GZ-35404	

FABRICATED STEEL BENCH VISES

- With an all steel construction, these fixed base Vises are built to withstand the shocks of hammering, chipping and other tough applications.
- Each Vise has an integrated anvil for shaping and beating, together with an extra heavy-duty sliding jaw and large diameter screw. Forged tommy bar along with the steel main screw helps in effective transmission of pressure on the work piece.
- Carbon Steel jaws are hardened 50 ± 5 HRC to withstand tough use and are serrated for non-slip grip. Safety stopper provided at the end of slide prevents slide from fall during usage.



Offset Jaw Vise

Part No.	Code	Jaw Width	Jaw Opening
Straight Jaw Vise			
GZ-35450	EBV/F/100	100mm	120mm
GZ-35451	EBV/F/150	150mm	150mm
GZ-35452	EBV/F/200	200mm	200mm
Offset Jaw Vises			
GZ-35460	OBV/F/100	100mm	120mm
GZ-35461	OBV/F/150	150mm	175mm
GZ-35462	OBV/F/200	200mm	200mm

REVERSIBLE VISE

- A compact and convenient vise suitable for a variety of DIY applications. Unique design additionally allows it to be used as a Pen Press.
- Made from cast iron, the body and sliding jaw are aligned with two steel guide rods and the main screw for smooth action. Polypropylene jaws impart a soft yet firm grip. Under pressure these jaws deform around the work piece and return to their original shape when the work is removed.
- Jaw capacity can be doubled from 90mm (3-1/2") to 175mm (7") by removing the sliding jaw and placing it at the back of the body, making the vise reversible.
- With a 360° swivel base this is amongst the most versatile and convenient work holding tools.



Part No.	Code	Jaw Opening
GZ-35530	RV/75-175	90 / 175mm

BENCH VICES

BENCH VICES

- Hardened steel jaws
- Close grained cast iron body



Part No.	Jaw Width	Weight
TM098-100	100mm	7kg

SWIVEL BASES

- To suit mechanics bench vices

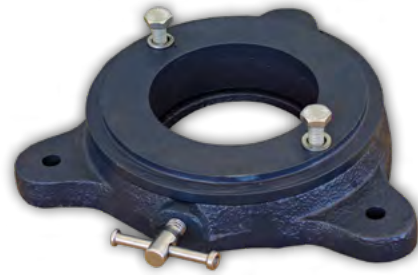

Part No.	To suit
TM110-075	TM100-075
TM110-100	TM100-100
TM110-125	TM100-125
TM110-150	TM100-150
TM110-200	TM100-200

FABRICATED STEEL BENCH VICES

- Extra heavy-duty
- Precise sliding jaw
- Large diameter screw
- Precision machined knurled jaws with V-Groove



PROFESSIONAL MECHANICS BENCH VICES

- Rugged all cast iron construction
- Integrated anvil for shaping and beating
- Extra heavy-duty sliding jaw and large diameter screw
- 50 ± 5 HRC hardened carbon steel jaws



Packaged in colour box

Part No.	Jaw Width	Weight
TM100-075	75mm	7.5kg
TM100-100	100mm	10kg
TM100-125	125mm	15.5kg
TM100-150	150mm	18kg
TM100-200	200mm	31kg

Part No.	Jaw Width	Jaw Type	Weight
TM102-100	100mm	Straight	10.5kg
TM102-125	125mm	Straight	18.5kg
TM102-150	150mm	Straight	22.6kg
TM102-200	200mm	Straight	37kg
TM104-100	100mm	Offset	11.2kg
TM104-125	125mm	Offset	20.3kg
TM104-150	150mm	Offset	25kg
TM104-200	200mm	Offset	60kg

HOBBY VISES

Groz manufactures a complete range of compact vises for a wide variety of metal and woodworking applications. While ideal for use by model makers and DIY enthusiasts, these can also be used by the serious craftsman for light duty jobs. Manufactured from high quality grey iron castings, these are machined to close tolerances resulting in smooth operation and reliability. Vises have an attractive enamelled finish with main screw and handle in chrome plated finish.

HOBBYIST VISES



Part No.	Code	Jaw Width
GZ-35510	TBV/FB/32	32mm
GZ-35512	TBV/FB/50	50mm
GZ-35514	TBV/FB/75	75mm

HOBBYIST VISES WITH INTEGRATED CLAMP



Part No.	Code	Jaw Width	Clamp Capacity
GZ-35523	TBV/C/50	50mm	35mm
GZ-35525	TBV/C/75	75mm	45mm
GZ-35526	TBV/C/100	100mm	45mm

HOBBYIST VISES WITH SWIVEL BASES

For applications that involve working in confined spaces, the swivel base vise is the ideal answer.



Part No.	Code	Jaw Width
GZ-35517	TBV/SB/50	50mm
GZ-35519	TBV/SB/75	75mm

HOBBYIST VISE WITH INTEGRATED CLAMP AND SWIVEL BASE



Part No.	Code	Jaw Width	Clamp Capacity
GZ-35520	TBV/RC/50	50mm	38mm

PUNCHES

CENTRE PUNCHES HEAVY DUTY

- Manufactured from hardened and tempered carbon steel, designed for demanding industrial use. These Centre Punches are ideal for clearly marking metal in work layout & making indentations in a work piece before drilling to ensure correct location of drill points.
- The working tips are centred and ground to the correct angle (90° included angle) for increased efficiency in marking. The striking end is chamfered to prevent breakage.
- Single piece construction with hexagonal shank, these are amongst the strongest and most durable of Centre Punches. Working ends are accurately ground and the punch body is in premium powder coated finish.



Part No.	Code	Point Size (P)		Stock Size		Overall Length	
		Inch	mm	Inch	mm	Inch	mm
GZ-25200	CP/HD/5-64	5/64"	2	1/4"	6	3-1/2"	90
GZ-25201	CP/HD/1-8	1/8"	3	5/16"	8	4-1/4"	108
GZ-25202	CP/HD/5-32	5/32"	4	3/8"	10	5"	125
GZ-25203	CP/HD/1-4	1/4"	6	1/2"	12	6"	150
GZ-25204	CP/HD/3-8	3/8"	10	5/8"	16	6-1/4"	160

CENTRE PUNCH SET HEAVY DUTY



Part No.	Code	Description
GZ-25205	CP/HD/5/ST	A Set Of 5 Centre Punches Containing One Each Of 5/64", 1/8", 5/32", 1/4" & 3/8" Packed In A Vinyl Pouch

CENTRE PUNCHES ROUND HEAD

Single piece construction with round shank and round striking head. This range of punches have a rust inhibiting black oxide finish.



GZ-25120



GZ-25109

Part No.	Code	Contents
GZ-25109	CP/5/ST	A Set Of 5 Centre Punches In Sizes 1-16", 5/64", 3/32", 9/64" & 5/32" Packed In A Vinyl Pouch
GZ-25120	CP/8/WD/ST	A Set Of 8 Centre Punches In Sizes 1/16", 5/64", 3/32", 1/8", 9/64", 5/32", 3/16" & 7/32" Packed In A Wooden Box

AUTOMATIC CENTRE PUNCH LIGHT DUTY

- Automatic single hand operated spring loaded punch.
- The built in mechanism delivers a punch just with the pressing of the head.
- The depth of the impression is variable and can be adjusted from light marking to heavy blows by turning the knurled head.
- Tips are made from hardened tool steel and can be easily removed for re-sharpening or replacement.



Part No.	Code	Body Diameter		Overall Length	
		Inch	mm	Inch	mm
GZ-25000	ACP/1B	1/2"	13	4.3/4	120

NAIL PUNCHES

- Manufactured from high grade carbon steel, accurately hardened and tempered for increased service life. Clean-cut knurled round shank provides a positive non-slip grip. The 9.5mm (3/8") square head provides a larger striking area and also prevents the punch from rolling off. The striking end is chamfered to prevent breakage. This range of punches has a black oxide finish.
- Nail Punches are designed for driving nail heads below the surface of wood. The working end is cupped to follow the nail head without sliding off. These can also be used to remove nails that have an exposed point.



Part No.	Code	Tip Diameter		Overall Length	
		Inch	mm	Inch	mm
GZ-25360	NLP/SQ/1-32	1/32"	0.8	4	100
GZ-25361	NLP/SQ/1-16	1/16"	1.5	4	100
GZ-25362	NLP/SQ/3-32	3/32"	2.5	4	100
GZ-25363	NLP/SQ/1-8	1/8"	3	4	100

NAIL PUNCH SET

- Includes sizes 1/32", 1/16" & 3/32"



Part No.	Code	Description
GZ-25366	NLP/SQ/3/ST	Nail Punch Set, 1/32", 1/16" & 3/32"

STARTING PUNCHES

- These Punches are used as a starting tool prior to using Pin Punches, as they are useful for loosening frozen or tight pins and keys, or knocking out rivets. These have a single piece construction with hexagonal shank.
- Manufactured from high grade carbon steel, they are accurately hardened for extended service life. The working ends are machine ground with the body in premium powder coated finish.



Part No.	Code	Tip Diameter (D)		Stock Size		Overall Length	
		Inch	mm	Inch	mm	Inch	mm
GZ-25700	SGP/HD/1-16	1/16"	1.5	3/8"	10	5"	125
GZ-25702	SGP/HD/1-8	1/8"	3	3/8"	10	5"	125
GZ-25703	SGP/HD/5-32	5/32"	3	3/8"	10	5"	125
GZ-25704	SGP/HD/3-16	3/16"	5	3/8"	10	5"	125
GZ-25706	SGP/HD/1-4	1/4"	6	3/8"	10	5"	125
GZ-25707	SGP/HD/5-16	5/16"	8	1/2"	12	6"	150

PRICK PUNCH

Prick Punches are used for marking metals in work layouts. These punches have a very sharp point (60° included angle), hence are highly suitable where very precise marking or scoring is required. These have a single piece construction with hexagonal shank. Manufactured from high quality carbon steel, they are accurately hardened for extended service life. The working ends are machine ground with the body in premium powder coated finish.



Part No.	Code	Point Size (P)		Stock Size		Overall Length	
		Inch	mm	Inch	mm	Inch	mm
GZ-25451	PKP/HD/3-8	5/32"	4	3/8"	100	5"	125

DRIFT PUNCHES

- Manufactured from high grade carbon steel, these have a single piece construction. Accurately hardened and tempered for increased working life. The working ends are machine ground with the body in premium powder coated finish.
- Ideal for lining up holes in 2 or more pieces of metal and for drawing pins through various assemblies. These are also referred to as "Alignment Punches".



Part No.	Code	Tip Diameter (D)		Stock Size		Overall Length	
		Inch	mm	Inch	mm	Inch	mm
GZ-25801	DFP/HD/1-8	1/8"	3	5/16"	8	8	200
GZ-25802	DFP/HD/5-32	5/32"	4	3/8"	10	9	225
GZ-25803	DFP/HD/3-16	3/16"	5	1/2"	12	10	250

ROLL PIN PUNCHES

Single piece construction with hexagonal shank imparts additional durability. Body has a premium powder coated finish with chamfered striking end that helps reduce mushrooming & chipping.

The heat-treated point has a rounded ball to centre the point into the pin allowing the point shoulder to maintain maximum contact with the pin during removal and eliminating any damage to the pin or wall.



Part No.	Code	Ball Diameter (D)	Stock Size	Overall Length
GZ-25640	RPP/3-32	2.5mm	6mm	89mm
GZ-25641	RPP/1-8	3mm	6mm	94mm
GZ-25642	RPP/5-32	4mm	8mm	114mm
GZ-25643	RPP/3-16	5mm	8mm	114mm
GZ-25644	RPP/1-4	6mm	10mm	140mm
GZ-25645	RPP/5-16	8mm	10mm	150mm

ROLL PIN PUNCH SET



Part No.	Code	Description
GZ-25646	RPP/6/ST	Roll Pin Punch Set, 6 piece, 2.5mm, 3mm, 4mm, 5mm, 6mm & 8mm Ball Diameters

PIN PUNCH SETS

GENERAL PURPOSE ROUND SHANK

These round shank pin punches have clean and well cut knurling which provides positive, non slip grip. These sets of punches have rust inhibiting black oxide finish.



GZ-25580

4" (100MM) PIN PUNCH SETS

Single piece construction with a 45mm (1-3/4") long pin.

Part No.	Code	Contents
GZ-25568	PP/4/ST	1/8", 5/32", 3/16" & 1/4" Packed In A Vinyl Pouch
GZ-25580	PP/8/WD/ST	1/16", 3/32", 1/8", 5/32", 3/16", 7/32", 1/4" & 5/16" Packed In A Round Wooden Case

8" (200MM) PIN PUNCH SETS

Two piece construction with a 90mm (3-3/4") long pin. The two piece construction allows the pin to have a separate hardness from the body which prevents "peening" and also ensures complete straightness over such a long length.



GZ-25508

Part No.	Code	Contents
GZ-25508	DDP/5/ST	1/8", 3/16", 1/4", 5/16" & 3/8" packed in a vinyl pouch
GZ-25509	DDP/8/ST	1/16", 3/32", 1/8", 5/32", 3/16", 1/4", 5/16" & 3/8" Packed In A Vinyl Pouch

PIN PUNCHES HEAVY DUTY

- Pin Punches are manufactured from high quality carbon steel, accurately hardened and tempered so that the Pin will withstand continuous use and the striking end will not splinter. These are induction hardened to ensure consistent hardness and a special tempering process prevents the head from fracturing, thereby preventing accidents.
- Single piece construction with hexagonal shank. Imparts additional durability to the punch. Working ends are accurately ground and the punch body is in premium powder coated finish.



Part No.	Code	Pin Diameter (D)		Stock Size		Overall Length	
		Inch	mm	Inch	mm	Inch	mm
GZ-25601	PP/HD3-32	3/32"	2.5	5/16"	8	4-1/2"	112
GZ-25602	PP/HD1-8	1/8"	3	5/16"	8	4-3/4"	119
GZ-25603	PP/HD5-32	5/32"	4	5/16"	8	5"	125
GZ-25604	PP/HD3-16	3/16"	5	3/8"	10	5-1/4"	132
GZ-25606	PP/HD1-4	1/4"	6	3/8"	10	5-3/4"	145
GZ-25607	PP/HD5-16	5/16"	8	7/16"	11	6"	150

PIN PUNCH SET HEAVY DUTY



Part No.	Code	Description
GZ-25612	PP/HD/6/ST	A Set Of 6 Pin Punches Containing One Each 3/32", 1/8", 5/32", 3/16", 1/4" & 5/16" Packed In A Vinyl Pouch

EXTRA LONG PIN PUNCHES HEAVY DUTY

The extra Long Pin Punches are useful for all applications where added leverage is required.



Part No.	Code	Pin Diameter (D)		Stock Size		Overall Length	
		Inch	mm	Inch	mm	Inch	mm
GZ-25650	PP/HD1-8L	1/8"	3	5/16"	8	8"	200
GZ-25651	PP/HD3-16L	3/16"	5	3/8"	10	8"	200
GZ-25652	PP/HD1-4L	1/4"	6	3/8"	10	8"	200
GZ-25653	PP/HD5-16L	5/16"	8	7/16"	11	8"	200
GZ-25654	PP/HD3-8L	3/8"	10	1/2"	12	8"	200

EXTRA LONG PIN PUNCH SET HEAVY DUTY



Part No.	Code	Description
GZ-25655	PP/HD/5L/ST	A Set Of 5 Extra Long Pin Punches Containing One Each Of 1/8", 3/16", 1/4", 5/16" & 3/8" Packed In A Vinyl Pouch

HOLLOW PUNCHES

- Designed for punching round holes in gasket material, leather, rubber, canvas, cardboard, plastic & soft material
- Cutting edge is induction hardened for extended life



Part No.	Code	Size
Hollow Punches		
GZ-26304	HPL/4	4mm
GZ-26305	HPL/5	5mm
GZ-26306	HPL/6	6mm
GZ-26308	HPL/8	8mm
GZ-26310	HPL/10	10mm
GZ-26311	HPL/11	11mm
GZ-26312	HPL/12	12mm
GZ-26313	HPL/13	13mm
GZ-26314	HPL/14	14mm
GZ-26316	HPL/16	16mm
GZ-26318	HPL/18	18mm
GZ-26319	HPL/19	19mm
GZ-26320	HPL/20	20mm
GZ-26322	HPL/22	22mm
GZ-26325	HPL/25	25mm
Arch Punches		
GZ-26328	HPL/28	28mm
GZ-26330	HPL/30	30mm
GZ-26332	HPL/32	32mm
GZ-26335	HPL/35	35mm
GZ-26338	HPL/38	38mm
GZ-26340	HPL/40	40mm
GZ-26350	HPL/50	50mm

HOLLOW PUNCH SETS



Part No.	Code	Size
GZ-26391	HPL/6/ST	Hollow Punch Set, 6 Piece, 5, 6, 8, 10, 11 & 12mm

ARCH PUNCH SET



Part No.	Code	Size
GZ-26441	HPL/7/BEL/ST	Arch Punch Set, 7 Piece, 6, 10, 12, 16, 19, 22 & 25mm

STEEL NUMBER PUNCH STAMPS FOR HAND HELD, HAMMER STRUCK APPLICATIONS

Manufactured from quality carbon steel. Punches are induction hardened, which gives durability and extended life for repeated use. The hardness at the stamping end is maintained at 58-62 HRC, the striking end is tempered to 38-43 HRC. This prevents the punch from splintering during use. The striking end is chamfered to prevent breakage.



Part No.	Code	Size
Number Punches		
GZ-25902	NP/3	3mm
GZ-25903	NP/4	4mm
GZ-25904	NP/5	5mm
GZ-25905	NP/6	6mm
GZ-25906	NP/8	8mm
GZ-25907	NP/10	10mm
GZ-25908	NP/12	12mm
Letter Punches		
GZ-26102	LP/3	3mm
GZ-26103	LP/4	4mm
GZ-26104	LP/5	5mm
GZ-26105	LP/6	6mm
GZ-26106	LP/8	8mm
GZ-26107	LP/10	10mm
GZ-26108	LP/12	12mm

PUNCH & CHISEL KITS

A range of kits carefully thought about, keeping in mind the needs of the tradesman, the farmer, the mechanic and the carpenter. This is an excellent way to keep your tools organised. These kits are packed in heavy duty vinyl rolls for easy access, organisation and storage.

8 PIECE SET



- Cold Chisels: 13 x 150mm, 16 x 163mm, 19 x 175mm
- Centre Punches: 5/32"
- Pin Punches: 1/8", 3/16", 1/4"
- Starting Punches: 3/16"

Part No.	Code	Description
GZ-33000	KIT/8/ST	8 Piece Punch & Chisel Set

16 PIECE SET



- Cold Chisels: 8 x 125mm, 13 x 150mm, 16 x 163mm, 19 x 175mm, 22 x 200mm
- Centre Punches: 1/8", 5/32", 1/4"
- Pin Punches: 1/8", 3/16", 1/4"
- Starting Punches: 1/8", 3/16", 1/4"
- Drift Punches: 3/16", 1/4"

Part No.	Code	Description
GZ-33002	KIT/16/ST	16 Piece Punch & Chisel Set

24 PIECE SET



- Cold Chisels: 6 x 125mm, 8 x 125mm, 10 x 140mm, 13 x 150mm, 16 x 163mm, 19 x 175mm, 22 x 190mm
- Centre Punches: 5/64", 5/32", 1/4"
- Pin Punches: 1/16", 3/32", 1/8", 5/32", 3/16", 1/4", 5/16"
- Starting Punches: 1/16", 1/8", 5/32", 3/16", 1/4", 5/16"
- Automatic Centre Punch: 33/64"

Part No.	Code	Description
GZ-33003	KIT/24/ST	24 Piece Punch & Chisel Set

14 PIECE SET



- Cold Chisels: 10 x 140mm, 13 x 150mm, 16 x 163mm, 19 x 175mm, 22 x 190mm
- Centre Punches: 5/32", 1/4"
- Pin Punches: 1/16", 1/8", 3/16"
- Drift Punches: 1/8", 5/32"
- Starting Punches: 5/16", 1/8"

Part No.	Code	Description
GZ-33001	KIT/14/ST	14 Piece Punch & Chisel Set

26 PIECE SET



- Cold Chisels: 6 x 125mm, 8 x 125mm, 10 x 140mm, 13 x 150mm, 16 x 163mm, 19 x 175mm, 22 x 190mm, 25 x 200mm, 13 x 300mm
- Centre Punches: 5/32", 1/4", 3/8"
- Pin Punches: 3/32", 1/8", 5/32", 3/16", 1/4", 3/8"
- Starting Punches: 1/16", 1/8", 3/16", 1/4"
- Drift Punches: 1/8", 3/16", 1/4"
- Prick Punch: 5/32"

Part No.	Code	Description
GZ-33004	KIT/26/ST	26 Piece Punch & Chisel Set

CHISELS & BOLSTERS

COLD CHISELS

- Manufactured to the highest safety standards, individually forged from high quality alloy steel. The alloy content in these makes them ideal for all types of metalworking and masonry applications and also increases wear resistance significantly. The precisely ground cutting edge is induction hardened (52 – 58 HRC) to give improved performance over longer periods of time. Hardness at the striking end is maintained to under 42 HRC, so that the head will not splinter when subject to hammer blows. The shank is powder coated and cutting edge is accurately ground.
- Octagonal Chisels are used for general work on cutting and chipping of metals, and shaping, facing and cutting of stonework. The extra long chisels are useful for all cutting and shaping jobs where extra length is required. The larger size cold chisels are also available with strong impact proof polypropylene hand guards. These are designed to protect the user's hands from misplaced hammer blows.



Part No.	Code	Blade Width	Overall Length
Octagonal Cold Chisels			
GZ-32800	CHS/ST/5/1-4	6mm	125mm
GZ-32801	CHS/ST/5/5-16	8mm	125mm
GZ-32802	CHS/ST/5.5/3-8	10mm	140mm
GZ-32803	CHS/ST/6/1-2	13mm	150mm
GZ-32804	CHS/ST/6.5/5-8	16mm	163mm
GZ-32805	CHS/ST/7/3-4	19mm	175mm
GZ-32818	CHS/ST/8/1-2	13mm	200mm
GZ-32825	CHS/ST/8/3-4	19mm	200mm
GZ-32826	CHS/ST/10/3-4	19mm	250mm
GZ-32812	CHS/ST/12/3-4	19mm	300mm
GZ-32823	CHS/ST/10/0-1	25mm	250mm
GZ-32814	CHS/ST/12/0-1	25mm	300mm

COLD CHISEL SET



Part No.	Code	Description
GZ-32830	CHS/ST/6/ST	Cold chisel set, 6 piece, 6x125mm, 8x125mm, 10x140mm, 13x150mm, 16x163mm & 19x175mm Packed In A Vinyl Pouch

COLD CHISELS WITH GRIP

- As per the standard cold chisels but with strong impact proof polypropylene hand guards. These are designed to protect the user's hands from misplaced hammer blows.



Part No.	Code	Blade Width	Overall Length
GZ-32841	CHS/ST/10/3-4GRP/TE	19mm	250mm
GZ-32843	CHS/ST/12/3-4GRP/TE	19mm	300mm
GZ-32842	CHS/ST/10/0-1GRP/TE	25mm	250mm
GZ-32844	CHS/ST/12/0-1GRP/TE	25mm	300mm

BRICK BOLSTERS

- Manufactured as a single piece, forged from high quality carbon steel. Accurately hardened to BS 3066 specification.
- The cutting edge is hardened 52 - 58 HRC with the striking end maintained under 42 HRC.
- The complete Bolster is powder coated and the cutting edge is accurately ground.
- Available with polypropylene hand guards. These hand guards are designed to protect the user's hands from misplaced hammer blows.



GZ-32622



GZ-32602

Part No.	Code	Blade Width	Overall Length
Bolsters Without Grip Guard			
GZ-32601	BRC/75	75mm	230mm
GZ-32602	BRC/100	100mm	230mm
Bolsters With Grip Guard			
GZ-32621	BRC/75/GRP/YE	75mm	230mm
GZ-32622	BRC/100/GRP/YE	100mm	230mm

ELECTRICIAN'S BOLSTERS / FLOOR CHISELS

With a much thinner blade construction than a Brick Bolster, Electricians Floorboard Bolsters are used for cutting tongued joints & lifting floorboards.



Part No.	Code	Blade Width	Overall Length
Bolsters Without Grip Guard			
GZ-32642	FLR/CHS/9/2-1-2	63mm	225mm
Bolsters With Grip Guard			
GZ-32643	FLR/CHS/9/2-1-2/GRP/YE	63mm	225mm

HAND SCRAPERS

- Designed for removing high spots on machined surfaces.
- For smooth and even surface on slideways, bearings, cast iron surface plates and precision marking out plates.
- Manufactured from high grade steel, hardened to 55-60 HRC and lightly tempered for lasting durability.
- All sizes have round wooden handle for comfortable grip during use.



Part No.	Code	Overall Length
Flat Hand Scraper		
GZ-14600	ES/F/4	100mm
GZ-14603	ES/F/6	150mm
GZ-14606	ES/F/8	200mm
Half Round Hand Scraper		
GZ-14601	ES/HR/4	100mm
GZ-14604	ES/HR/6	150mm
GZ-14607	ES/HR/8	200mm
Triangular Hand Scraper		
GZ-14602	ES/T/4	100mm
GZ-14605	ES/T/6	150mm
GZ-14608	ES/T/8	200mm

TWEEZERS & WHEEL DRESSERS

TWEEZERS SET

- Tweezers are used for picking up small objects that are not easily handled by hands.
- Manufactured from stainless steel. Tweezers make use of two levers connected at one fixed end called the fulcrum with pincers at the other.
- These are extensively used for servicing & repairs in electronics, computers, instruments, radio and other subminiature assemblies.



Part No.	Code	Description
GZ-03720	TWZ/ST-6	Tweezers Set, 6 Piece

WHEEL DRESSERS & CUTTERS



This range of Wheel Dressers are designed for dressing, truing, sharpening and removing glaze from solid abrasive wheels. Body is powder coated. The cast iron handle is ergonomically designed for comfortable grip.

The cutters have star shaped teeth that expose new grains and provide a fresh unloaded surface on wheels. Cutters are also available as spares - set of 4.

Part No.	Code	Size	Dresser Wheel Range	Dresser Length	Cutter Diameter
Wheel Dressers					
GZ-12070	WD/00	0	500mm	255mm	32mm
GZ-12071	WD/01	1	750mm	270mm	38mm
GZ-12072	WD/02	2	Large Sizes	320mm	60mm
Wheel Dresser Cutters					
GZ-12080	WDC/00	-	-	-	32mm
GZ-12081	WDC/01	-	-	-	38mm
GZ-12082	WDC/02	-	-	-	60mm

LED LIGHTS

LED FLASHLIGHT AND LASER POINTER

- 18 lumens
- Laser pointer for pointing out hard to reach areas
- Aluminium body
- 2 modes - 8 white LED, 1 red laser pointer
- 20m beam distance
- 5.5 hour battery life
- Supplied with 3x AAA batteries



Part No.	Code	Description
GZ-LED100	LED-100	LED Flashlight And Laser Pointer

LED UV INSPECTION LIGHT

- Emits long wave length 385 Nm ultraviolet light - powerful enough to make gems and mineral fluoresce even in room lighting
- Aluminium body
- Supplied with 3x AAA batteries



Part No.	Code	Description
GZ-LED120	LED-120	LED UV Inspection Light

MULTI USE LED WORK LIGHT AND TORCH

- 28 lumens
- 7x white LED flashlight
- 18x white LED work light
- 6x red LED emergency light
- Aluminium body
- Magnetic base
- Supplied with 3x AAA batteries



Part No.	Code	Description
GZ-LED301	LED-301	Multi Use LED Work Light And Torch

LED FLASHLIGHT WITH MAGNETIC TELESCOPIC PICK UP

- 8 lumens
- Aluminium body
- Telescopic body extends from 170mm to 550mm
- Flexible shaft
- Magnetic head - ideal for picking up objects in hard to reach places
- Supplied with 4x 1.5 LR44 batteries



Part No.	Code	Description
GZ-LED130	LED-130	LED Flashlight With Magnetic Telescopic Pick Up

PROFESSIONAL LED HEAD LAMP

- 100 lumens
- ABS body with aluminium lens holder
- Adjustable head positioning with foam pad for comfort
- Built in zoom feature with magnification from 1x to 2000x
- 100m beam distance
- 3 modes - low, high and flash
- 6 hour battery life
- Supplied with 3x AAA batteries



Part No.	Code	Description
GZ-LED200	LED-200	Professional LED Head Lamp

PROFESSIONAL LED HEAD LAMP WITH SENSOR

- 120 lumens
- Built in hand sensor, wave hand in front of lamp to activate
- 100m beam distance
- 3 modes - low, high and flash
- 6 hour battery life
- Supplied with 3x AA batteries



Part No.	Code	Description
GZ-LED205	LED-205	Professional LED Head Lamp With Sensor

LED HEAD LAMP

- 12 lumens
- 10m beam distance
- 3 modes - low, high and flash
- 7 hour battery life
- Supplied with 1x AA battery



Part No.	Code	Description
GZ-LED210	LED-210	LED Head Lamp

LED MINI FLASH LIGHT

- 35 lumens
- Aluminium body
- 4 pack
- 30m beam distance
- Soft rubber grip and belt clip
- 3 hour battery life
- Supplied with 2x AA and 8x button batteries



Part No.	Code	Description
GZ-LED110	LED-110	LED Mini Flash Light

LED INSPECTION LAMP

- 48 lumens
- Inspection lamp with impact resistant rubberised coating
- 24 super bright LEDs
- Magnetic back
- 360° swivel hook
- Supplied with 3x AA batteries



Part No.	Code	Description
GZ-LED320	LED-320	LED Inspection Lamp

MINI LED WORK LIGHT AND TORCH

- 36 lumens
- ABS body
- Magnetic attachment on swivel clip
- 11 hour battery life
- Supplied with 3x AAA batteries



Part No.	Code	Description
GZ-LED330	LED-330	Mini LED Mini Flash Light And Torch



SHARPENING MACHINES

Drill Bit Sharpeners - KEF	131
Knife Sharpeners - Worksharp	132
Drill Bit Sharpeners - Drill Doctor	140
Drill Bit Sharpeners - Darex	142
Annular Cutter Sharpeners - Holemaker	145



DRILL BIT SHARPENERS - KEF

LARGE CAPACITY

HIGHEST QUALITY DANISH DRILL BIT SHARPENERS

Uncomplicated - KEF drill grinders are based on a well proven grinding method which always results in flawless and accurately ground drill points. KEF Sharpeners are pre-set for grinding twist drills, for drilling in steel and iron, with point angle 116° - 118° and clearance angle 6° - 8°. The simplified design ensures that a wide range of different drill sizes can be ground without complicated and time consuming re-setting. Therefore unskilled operators can also obtain good results.

KEF-6NE PROFESSIONAL DRILL BIT SHARPENER 30MM DRILL BIT CAPACITY



Part No.	KEF-6NE
Drill Capacity	4 - 30mm
Point Angle	116° - 118°
Relief Angle	6° - 8°
Motor	480W
Voltage	240V 1PH
Weight	25kg

KEF-8NE PROFESSIONAL DRILL BIT SHARPENER 60MM DRILL BIT CAPACITY



Part No.	KEF-8NE
Drill Capacity	4 - 60mm
Point Angle	116° - 118°
Relief Angle	6° - 8°
Motor	750W
Voltage	240V 1PH
Weight	34kg

KEF-PSD5 HEAVY DUTY DRILL BIT SHARPENER 60MM DRILL BIT CAPACITY

Supplied on a pedestal with table & water cup



Part No.	KEF-PSD5
Drill Capacity	4 - 60mm
Point Angle	116° - 118°
Relief Angle	6° - 8°
Motor	1100W
Voltage	415V 3PH
Weight	70kg

Magnetic Base Drilling Machines

Cutting Tools

Clamps

Engineer's Tools

Sharpening Machines

Metal Cutting Saws

Drilling Machines

Bevelling Machines & Welding Carriages

Punches & Shears

Grinding Machines

Fans & Ventilators

Workshop Storage

M7 Airtools

NPK Airtools

Pneumatic Products



KNIFE & TOOL SHARPENERS



KNIFE & TOOL SHARPENER
KEN ONION EDITION
WSKTS-KO

GUIDED FIELD SHARPENER
WSGFS221



GUIDED SHARPENING SYSTEM
WSGSS



KNIFE & TOOL SHARPENER
WSKTS



www.worksharptools.com.au

CHISEL & TOOL SHARPENERS - WORKSHARP

WorkSharp - from the makers of Drill Doctor, is a grinding & sharpening system for sharpening chisels, plane blades, scrapers, axes and much more with speed & precision. The 2 sided grinding wheel allows you to quickly and easily switch between coarse and fine abrasive disks. WorkSharp is fast, easy to use & works every time. 4 Patents pending. 2 year warranty.

WORKSHARP PROVIDES 3 WAYS TO EASILY SHARPEN & GRIND

1 EDGE VISION PORT



Using slotted wheels, the edge vision port allows you to see the cutting edge of your tools as you sharpen.

2 CHISEL PORT



Offering precise & repeatable bevel angles with a simple "Plunge & Pull" motion.

3 TOP SIDE



Wide general purpose grinding & sharpening surface for sharpening larger flat blade tools.

WS3000

- 20°, 25°, 30°, 35° Port sharpening angles
- 50mm Maximum sharpening port
- Wheel speed 580RPM
- Creates micro bevels
- Dry cooling system - routed airflow & heatsink system keeps tools cool
- Ceramic sharpening port increases burr removal and speeds sharpening
- Adjustable top tool rest
- Bench mounting tabs
- Cast aluminium & steel construction



Includes:

- WorkSharp 3000 Unit
- Edge vision slotted wheel & 2 tempered glass wheels
- Top tool rest
- Premium abrasive kit including 120, 400, 1000, 3600 Micro-Mesh adhesive backed abrasives
- Crepe stick, slotted abrasives 80, 400, 1200 grit



Part No.	Description
WS3000	WorkSharp 3000 Package
WSSA0002001	Leather Hone With Honing Compound
WSSA0002023	Replacement Glass Wheel
WSSA0002029	Replacement Slotted Wheel
WSSA0002010	Felt Polishing Wheel
WSSA0002011	Surface Conditioning Wheel
WSSA0002780	Belt Sharpening Attachment
WSSA0002781	WorkSharp 3000 Belt Sharpening Attachment Replacement Belts, 3Pce
WSSA0002002	Slotted Abrasive Kit Including 1 x P80, 2 x P400, 2 x P1200, 1 x Micro-Mesh
WSSA0002044	Micro-Mesh Abrasive Kit Including 1 x 3600 Micro-Mesh, 1 x 6000 Micro-Mesh
WSSA0002005	Coarse Abrasive Kit Including 2 x P80, 2 x P120, 3 x P220, 2 x P400 2" Square
WSSA0002043	Fine Abrasive Kit Including 4 x P400, 6 x P1000, 2 x P400 2" Square
WSSA0002601	Tool Bar Attachment - Accepts Tormek® Sharpening Jigs And Improves Control
WSSA0002574	WorkSharp 3000 Cover
WSSA0002020	WorkSharp 3000 Wide Blade Attachment



WSSA0002010
Felt Polishing Wheel



WSSA0002011
Surface Conditioning Wheel



WSSA0002780
Belt Sharpening Attachment



WSSA0002005
Coarse Abrasive Kit



WSSA0002574
WorkSharp 3000 Cover



WSSA0002020
Wide Blade Attachment

KNIFE SHARPENERS - WORKSHARP

KNIFE & TOOL SHARPENER SHARPENS EVERY KNIFE YOU OWN



240V POWERED SHARPENER USING FLEXIBLE ABRASIVE BELTS

SHARPENS EVERY KNIFE YOU OWN!

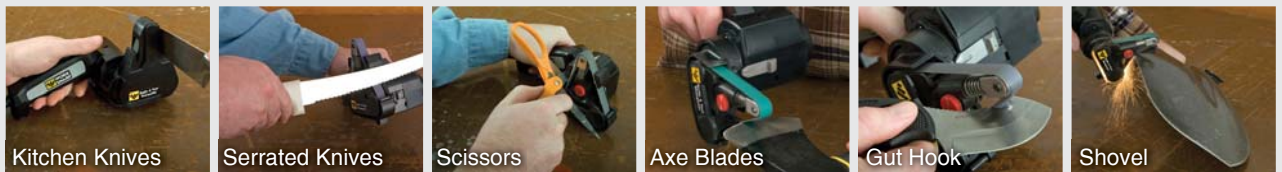

Flexible belt conforms to the shape of any blade

Sharpen your knife the way it was made. The WorkSharp Knife & Tool Sharpener gives you a perfect convex edge on any knife blade.

Features

- Pro - Level Sharpening Technology
- Fast and easy to use
- Won't burn or damage blade steel
- Precision sharpening guides for repeatable results
- Easily replaceable abrasive grit belts
- Heavy-duty manufacture



Contents

- Outdoor Knife Guide with 2 x 25° knife guides and a scissor guide
- Kitchen Knife Guide with 2 x 20° knife guides
- 5 x Abrasive Belts: 1x P80 Coarse Belt, 2x P220 Medium Belt, 2x 6000 Fine Honing Belt

Part No.	Description
WSKTS-I	Knife & Tool Sharpener



Pro - Level Sharpening Technology



Most knife sharpeners create a flat bevel on a blade. The edge gets thicker when re-sharpened, which increases friction.

Work Sharp's flexible belts create a superior convex grind on a blade. The edge is stronger, cuts better and stays sharper longer!

Knife makers use abrasive belts to sharpen knives. Now you can too! The Work Sharp Knife & Tool Sharpener gives you a perfect convex edge on any knife blade.

The secret is the flexible belt technology. The belt flexes to any blade shape and creates a strong, shaving edge on your blade. It even sharpens blades that other sharpeners can't. It's the sharpest edge you've ever used!

Optional Accessories & Consumables

WSKTS CANVAS STORAGE BAG



Part No.	Description
WSP0002759	Canvas Storage Bag

CERAMIC OXIDE 120 GRIT REPLACEMENT BELT



Intended for heavy grinding and blade shaping and profiling applications. This abrasive is very aggressive and only intended for high level users. This ceramic oxide abrasive is aggressive, long lasting and cool cutting. Use caution when grinding or shaping blade steels to not overheat the blade.

Part No.	Description
WSP0002822	Ceramic Oxide 120 Grit

CERAMIC OXIDE 220 GRIT REPLACEMENT BELT



Intended for light shaping and sharpening applications. Produces a toothy cutting edge for long life utility applications.

Part No.	Description
WSP0002515	Ceramic Oxide 220 Grit

ALUMINIUM OXIDE 80, 400 & 600 GRIT REPLACEMENT BELT



Intended for knife sharpening applications. Use to sharpen bevel and refine bevel surface finish. Not intended for initial bevel shaping. Ideal for resharpening already shaped blades that are dull or have minor edge damage. Can also be used for scissor and shear sharpening. J-wt. medium flex cloth backing, heat treated aluminum oxide, top coated for hard to grind or alloyed metals.

Part No.	Description
WSP0002454	Aluminium Oxide 80 Grit
WSP0002455	Aluminium Oxide 400 Grit
WSP0002456	Aluminium Oxide 600 Grit

SILICON CARBIDE 1800 GRIT REPLACEMENT BELT



Intended for blade sharpening. Can be used to sharpen scissors or knives after they have been shaped on a coarser grit. Ideal for refining the surface finish on blade edges. Ultra flexible cloth backing, cross compliant for serrations, fine surface and very hard and sharp SiC abrasive.

Part No.	Description
WSP0002375	Silicon Carbide 1800 Grit

SILICON CARBIDE 6000 GRIT REPLACEMENT BELT



Intended for honing applications. Similar to honing with a leather strop. Extremely fine edge for razor quality shave. Highly conformable to hone gut hooks and serrated edges. Very cool cutting for the most delicate blades such as razors and scalpels.

Part No.	Description
WSP0002409	Silicon Carbide 6000 Grit

DIAMOND 180 GRIT (MICROMESH) REPLACEMENT BELT



Diamond abrasive belt is intended for shaping and coarse sharpening ceramic knives. Not intended for steel blades. Ultra flexible cloth backing with very hard and sharp diamond abrasive.

Part No.	Description
WSP0002451	Diamond 180 Grit

DIAMOND 1500 GRIT (MICROMESH) REPLACEMENT BELT



Diamond abrasive belt is intended for honing and fine sharpening ceramic knives. Not intended for steel blades. Ultra flexible cloth backing with very hard and sharp diamond abrasive.

Part No.	Description
WSP0002452	Diamond 1500 Grit

REPLACEMENT BELT PACKS



Part No.	Description
WSSA0002012	Pack, 6pce, 2x 80 Grit, 2x 220 Grit, 2x 6000 Grit
WSSA0002703	Pack, 6pce 80 Grit. Intended For Coarse Shaping
WSSA0002704	Pack, 6pce 220 Grit (WSP0002515)
WSSA0002705	Pack, 6pce 6000 Grit (WSP0002409)
WSSA0002970	2pce Diamond Grit (Micromesh) 180 & 1500 Grit (WSP0002451 & WSP0002452)

KNIFE & TOOL SHARPENER - KEN ONION EDITION

Worksharp has partnered with legendary hall of fame knife maker Ken Onion to develop a new knife and tool sharpening platform with expanded features! The Worksharp Knife & Tool Sharpener Ken Onion Edition is designed to sharpen every knife you own. Using a fully adjustable precision sharpening guide, variable speed and wide flexible abrasive belts, it sharpens pocket and hunting knives, serrated knives, kitchen knives and any other shape or type of blade you own. Professional blade makers like Ken Onion use flexible belts to put a razor sharp edge on their blades, and now you can have the same technology in your home or shop. The combination of Worksharp engineering and Ken Onion's industrial design has created a fast, easy and stylish way to sharpen all your knives and tools with precision and repeatability.

Features

- The 3/4" x 12" premium, flexible engineered abrasive belts sharpen virtually any shape or type of knife blade and use a precision sharpening guide to ensure that you get a consistent angle every time
- The sharpening guide is fully adjustable in 1° increments from 15° to 30° so you can sharpen any knife to the angle you desire to best meet your needs
- The variable speed control 6000 to 14000rpm (1,200 SFM to 2,800 SFM) provides you with the optimal belt speed for the task at hand

Contents

- WSKTS-KO Machine
- 5 Pce abrasive belt kit : P120 extra coarse, X65 coarse, X22 medium, X4 fine, 6000 extra fine
- Adjustable Knife Sharpening Guide 15° to 30°
- User's Guide & Instructional DVD

Pro - Level Sharpening Technology



Most knife sharpeners create a flat bevel on a blade. The edge gets thicker when re-sharpened, which increases friction.

Work Sharp's flexible belts create a superior convex grind on a blade. The edge is stronger, cuts better and stays sharper longer!

Part No.	Description
WSKTS-KO	Worksharp Knife Sharpener Ken Onion Edition

REPLACEMENT BELTS FOR METAL BLADES



Part No.	WSP0002934	WSP0002936	WSP0002937	WSP0002938	WSP0002409
Belt Name	Extra Coarse	Coarse	Medium	Fine	Extra Fine
Grit	P120	X65 (P220)	X22 (P1000)	X4 (P3000)	P6000
Belt Material	Norton SG	Norax 65µ	Norax 22µ	Norax 4µ	SiC 2µ
Belt Size	3/4" x 12"	3/4" x 12"	3/4" x 12"	3/4" x 12"	1/2" x 12"
Uses	Tool Grinding & Blade Repair	Knife Shaping	Knife Sharpening	Knife & Scissor Honing	Serrated Blades & Gut Hook Honing

REPLACEMENT BELTS FOR CERAMIC BLADES



Part No.	WSP0002948	WSP0002949
Belt Name	Coarse	Fine
Grit	P180	P1200
Belt Material	Micro-Mesh	Micro-Mesh
Belt Size	3/4" x 12"	3/4" x 12"
Uses	Ceramic Knives	Ceramic Knives



WSKTS-KO REPLACEMENT BELT KIT

For use with WSKTS-KO

- 1pc P120 coarse grit
- 1pc X65 coarse grit
- 1pc X22 medium grit
- 1pc X4 fine grit
- 1pc 6000 extra fine grit



Part No.	Description
WSSAK081113	Belt Kit WSKTS-KO



REPLACEMENT BELTS FOR USE WITH WSKTS-KO

STOCK BELT KITS

Part No.	WSSAK081117	WSSAK081118	WSSAK081119	WSSAK0811120
Belt Name	Extra Coarse	Coarse	Medium	Fine
Grit	P120	X65 (P220)	X22 (P1000)	X4 (P3000)
Belt Material	Ceramic	Norax	Norax	Norax
Belt Size	3/4" x 12"	3/4" x 12"	3/4" x 12"	3/4" x 12"
Number of belts included	5	5	5	5
Uses	Coarse tool sharpening	Knife & scissor sharpening	Knife & scissor sharpening	Knife & scissor sharpening

KEN ONION OPTIONAL BELT KITS

- For sharpening ceramic blades

Part No.	WSSA0003552	WSSA0003553	WSSA0003560
Belt Name	Extra Coarse	Coarse	Medium
Grit	P80	X65 (P220)	X45
Belt Material	Ceramic	Ceramic	Norax
Belt Size	3/4" x 12"	3/4" x 12"	3/4" x 12"
Number of belts included	5	5	5
Uses	Shaping & profiling	Fine tool sharpening	Knife & scissor sharpening

FINE BELT KITS

- Clean sharpening, less grit and swarf.

Part No.	WSSA0003555	WSSA0003556
Belt Name	Extra Coarse	Coarse
Grit	A35	A5
Belt Material	Trizact Film	Trizact Film
Belt Size	3/4" x 12"	3/4" x 12"
Number of belts included	5	5
Uses	Knife & scissor sharpening	Knife & scissor sharpening

MICRO-MESH BELTS

Smoothing / polishing. Use for smoothing handles and polishing handles and stropping edges.

Part No.	WSSA0003557
Belt Name	Ultra Fine
Grit	P12000
Belt Material	Aluminum Oxide
Belt Size	3/4" x 12"
Number of belts included	5
Uses	Polishing / Stropping

STIFFER NORAX BELT KITS

Precision sharpening ideal for straight blades such as wharnclyffe and sheepsfoot. High belt stability useful for re-profiling blades and customization.

6 belts included :

- 1x X200 • 1x X45
- 1x X100 • 1x X22
- 1x X65 • 1x X5



DIAMOND BELT KITS

For sharpening ceramic blades. 2 belts included :

- 1x 180 grit
- 1x 1500 grit



Part No.	Description
WSSA0003562	Stiff Norax Belt Kit To Suit WSKTS-KO

Part No.	Description
WSSA0003561	2Pce Diamond Belt Kits, 180 & 1500 Grit To Suit WSKTS-KO

WSKTS-KO TOOL GRINDING ATTACHMENT

The WSKTS-KO Tool Grinding Attachment is designed for home workshop tool sharpening and grinding tasks. This two pulley Tool Grinding Attachment is designed with cast metal components to hold up to the rigors of grinding and sharpening tasks like axes and hatchets, mower blades, garden tools and almost any tool with a blade. It also makes a handheld belt sander or power file for a wide range of grinding tasks in metal, wood or plastics.

Features

- Quick belt changes due to spring tensioner lock out design
- Larger diameter drive pulley to achieve the optimal belt speed (4,500 SFM) for a wide range of grinding tasks
- On tool belt tracking
- Tool-less design enables quick installation and removal
- Features both flat platen and slack belt grinding styles

Includes

- Premium Norton extra coarse P60 grit Zirconia Alumina 3/4" x 12" engineered abrasive belts that are designed and intended for heavy stock removal and long life. Note : This attachment also accepts the standard WSKTS-KO belt mix for more light duty grinding or polishing tasks where a finer surface finish or less material removal is desired.



Part No.	Description
WSSAK081111	WSKTS-KO Tool Grinding Attachment

TOOL GRINDING ATTACHMENT REPLACEMENT BELTS



Part No.	Description
WSSAK081114	Belt Kit Including 6 x P60
WSPP0003110	Individual Belt 3/4" x 12" Extra Coarse Grit P60

WSKTS-KO BLADE GRINDING ATTACHMENT

The WSKTS-KO Blade Grinding Attachment is a horizontal belt attachment designed for knife shaping, sharpening and honing tasks. This attachment is similar in design to what blade makers use and provides a wide range of adjustability so you can custom shape, sharpen and hone your blades at home without the cost or size of full scale blade maker's equipment.

Features

- Fully adjustable from 10° to 35° (in 1° increments)
- Uses 1" x 18" engineered abrasive belts
- Adjustable belt deflection to customise the blade edge profile – a full convex or a near flat convex.
- Cast metal components and engineered polymers to hold up to the rigors of heavy sharpening tasks.
- Tool-less design enables quick installation and removal
- 1,200 SFM to 2,800 SFM belt speed
- Quick belt changes due to spring tensioner lock out design

Includes

- Cool cutting, engineered, long life 1" x 18" belts for shaping, sharpening, honing and stropping
- 1pc Norton Norax X65 (equivalent to P220)
- 1pc Norton Norax X22 (equivalent to P1000)
- 1pc Norton X4 (equivalent to P3000)
- 1pc Micro Mesh P12000



Part No.	Description
WSSAK081112	WSKTS-KO Blade Grinding Attachment

BLADE GRINDING ATTACHMENT REPLACEMENT BELTS



Part No.	Description
WSSAK081115	Belt Kit Including P120, X65, X22, X4, P12000
WSPP0002770	Individual Belt 1" x 18" Extra Coarse Grit P120
WSPP0003208	Individual Belt 1" x 18" Coarse Grit X65 (P220)
WSPP0002942	Individual Belt 1" x 18" Medium Grit X22 (P1000)
WSPP0002943	Individual Belt 1" x 18" Fine Grit X4 (P3000)
WSPP0002952	Individual Belt 1" x 18" Extra Fine Grit P12000
WSSAK081121	Polishing Belt Kit Including 1" x 18" Cloth Belt, 1x Green Chromium Oxide Cutting Compound, 1x Red Ferric Oxide Cutting Compound

GUIDED FIELD SHARPENER

5 STAGE SHARPENER WITH BUILT IN ANGLE GUIDES

The Work Sharp Guided Field Sharpener will sharpen your pocket knives, hunting knives, fillet knives, serrated knives and even bladed tools to a keen edge with speed and precision. It includes 2 Diamond Plates, 2 Ceramic Rods, 1 Leather Strop and Sharpening Guides to provide a fast, easy and consistent sharpening solution for knives and camp tools. The 20° and 25° sharpening guides create consistent blade edge angles with speed, ease and repeatability.

Strong rare earth magnets secure the easily interchangeable diamond plates and also provide coverage for the Broadhead Wrench and small storage compartment. It's compact design and Lanyard Hole make it easy to pack and carry on your next outdoor adventure so you can sharpen anytime, anywhere with speed and ease. Also sharpens fish hooks, broadheads and many other common camp tools.

Sharpens

- Standard Knives
- Broad Heads
- Axes & Machetes
- Serrated Knives
- Fish Hooks
- And So Much More!
- Scissors
- Garden Tools

Features and uses

- Built in angle guides
- Sharpen on diamond
- Hone on ceramic
- Strop on leather
- Hone serrated edges
- Sharpen fish hooks
- Broad head wrench
- Sharpen camp tools

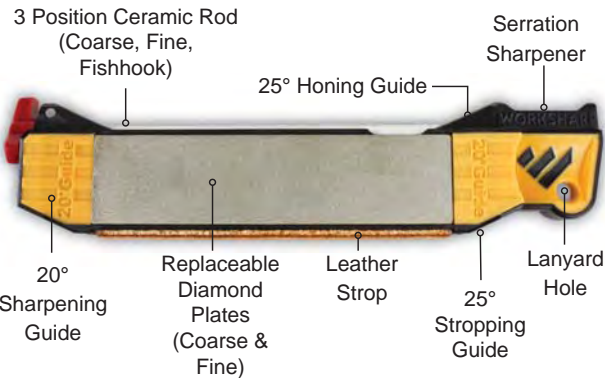

Part No.	Description
WSGFS221	Guided Field Sharpener



Diamond Guide



Ceramic Guide



Leather Strop

WORKSHARP GUIDED SHARPENING SYSTEM



The Work Sharp Guided Sharpening System is a complete sharpening solution for every knife you own. It features the innovative Pivot-Response System which allows the abrasive to follow the curve of the knife while sharpening - making manual sharpening faster, easier and more precise than ever. The Pivot-Response can also be locked out for traditional manual sharpening, creating the ideal sharpener for both the novice and expert alike. Sharpens pocket knives, hunting knives, serrations, tools and more.

Features

- Pivot-Response System
- Suitable for professionals and novices
- Easily replaceable sharpening plates and angle guides
- Heavy-duty manufacture
- 42-year warranty

Contents

- Angle-Guided Bench Sharpener
- 17° & 20° angle guides
- Interchangeable 320 grit coarse and 600 grit fine 6" Diamond Plates
- Angle-Guided Field Hone with a three-position ceramic rod (coarse, fine, fish hook groove), and two small diameter ceramic rods for serrations

Part No.	Description
WSGSS	Guided Sharpening System

WORKSHARP GUIDED SHARPENING SYSTEM UPGRADE KIT

Expand your Work Sharp Guided Sharpening system to repair damaged blades, sharpen a wider range of tools, or create the ultimate cutting edge!

The Guided Sharpening System Upgrade Kit includes two additional Diamond Plates (Extra Coarse 220 grit and Extra Fine 800 grit), and a Leather Strop Kit complete with a natural leather stropping plate, angle guides and 0.5 micron chromium oxide honing compound. The Diamond Plates and Leather Strop are 6" x 1.25" and are designed to fit the Guided Sharpening System.

The Extra Coarse Diamond Plate (220 grit) allows you to expand your sharpening capabilities to common edge tools, and is ideal for removing material quickly when repairing or re-profiling a knife. The Extra Fine Diamond Plate (800 grit) offers a refined sharpening experience, ideal when re-sharpening a knife or other fine edge tool. The Leather Strop is used as the final step when refining your knife edge to create the sharpest edge possible. The leather and honing compound combine to produce an incredibly keen edge for high performance cutting tasks.



Contents

- Extra coarse 220 grit diamond plate
- Extra fine 800 grit diamond plate
- Natural leather stropping plate
- 25° angle guides
- 0.5 micron chromium oxide honing compound



Part No.	Description
WSSA0003300-C	Guided Sharpening System Upgrade Kit

DRILL BIT SHARPENERS - DRILL DOCTOR

DRILL DOCTOR 750X TRADESMAN MODEL

Features

- Variable 2.5mm to 19mm drill bit capacity
- Variable 115° to 140° sharpening angle
- Creates & restores split point bits
- Adjustable relief angle
- Adjustable material removal
- 240V motor
- Moulded carry case



E-Z Alignment System

Fast, easy and assures precise sharpening alignment, even of small bits



Patented Dual-Cam Sharpening System

Professionally sharpen your bits with a few easy turns

Variable Alignment

Lets you adjust chisel & relief angle

Patented Chuck Design

Front loading chuck holds 2.5mm to 19mm (3/32" to 3/4") drill bits for precision geometry; makes small bits easy to align.



User Replaceable Diamond Sharpening Wheel

The diamond wheel is easy to replace after several hundred sharpenings

Part No.	DD750X
Drill Bit Capacity	2.5mm - 19mm (3/32" to 3/4")
Point Angle	115° to 140°
Voltage	240V 1PH

Variable Point Angle
115° to 140°

SHARPENING BITS WITH DRILL DOCTOR IS AS EASY AS 1 2 3

1 Insert Drill Bit



Insert the drill bit into the chuck jaws & tighten the chuck just to the point where the bit can only just slide in and out.

2 Align Drill Bit



While holding the alignment button down, insert the chuck and slide the drill bit forward until it touches the drill stop. Tighten the chuck firmly.

3 Sharpen!



Insert the chuck into the sharpening port and rotate one half turn in a clockwise direction repeatedly until the drill bit is sharp.

DRILL DOCTOR 500X TRADESMAN MODEL

The Drill Doctor 500X model is designed for the tradesman requiring a versatile sharpener for every day use. The 500X has the durability and the flexibility required to sharpen the largest range and most popular sizes of dull or broken bits, including split points and masonry bits.

Features

- Adjustable point angle
- Adjustable relief angle
- Creates & restores split point bits
- User replaceable diamond sharpening wheel



Part No.	DD500X
Drill Bit Capacity	2.5mm - 13mm (3/32" to 1/2")
Point Angle	118° or 135°
Voltage	240V 1PH

DRILL DOCTOR 360X HANDYMAN MODEL

The Drill Doctor 360X is ideal for the home workshop. It provides the home handyman, weekend craftsman, or hobbyist with the sharpening power needed to restore dull bits and keep on working. The 360X adds simplicity, stability and accuracy.

Features

- On chuck alignment, eliminates alignment port for simplified sharpening process
- User replaceable diamond sharpening wheel
- 1 year warranty



Part No.	DD360X
Drill Bit Capacity	2.5mm - 13mm (3/32" to 1/2")
Point Angle	118°
Voltage	240V 1PH

Works Every Time

Consistently sharpen bits as good or better than brand new

Convenient

Sharpen drill bits in the home, shop, garage or job site

Versatile

Re-sharpen standard, carbide, high speed steel, masonry, cobalt, TiN coated and parabolic twist drill bits

Fast

Sharpening a dull worn drill bit to precision sharpness takes less than a minute

The Drill Doctor Drill Bit Sharpener offers a powerful motor for smooth operation and Diamond grinding wheel providing long life & constant geometry without the need for wheel dressing. Suitable for sharpening High Speed Steel, Masonry, TiN Coated, Carbide, Cobalt & Parabolic twist drills. The Features of the DD500X / DD750X enable sharpening and modification of drill bits for special applications. Adjusting the sharpening angle enables drill bits to be custom sharpened to suit different materials and applications. Decreasing the Relief Angle is ideal for harder materials & masonry drills etc. Increasing the Relief Angle will provide a more aggressive cut. The Split Point Function is for restoring or creating self centring split point drill bits.



PARTS & ACCESSORIES

Part No.	Description
DDDA31325GF	100 Grit Diamond Wheel suit DD360X DD500X & DD750X
DDDA31320GF	180 Grit Diamond Wheel suit DD360X DD500X & DD750X
DDSA31120PA	13mm Chuck to suit DD360X
DDSA02100PA	13mm Chuck to suit DD500X & DD750X
DDDA70100PF	19mm Chuck to suit DD500X & DD750X
DDDA02105PF	13mm Chuck for use with Left Hand Spiral Drill Bits, to suit DD500X & DD750X
DD-BAG	Carry bag to suit DD360X

DRILL DOCTOR XP TRADESMAN MODEL

The DDXP is perfect for the serious DIY'er, hobbyist and the professional user with the sharpening power needed to restore dull bits and keep on working. The DDXP adds simplicity, stability and accuracy.

The Drill Doctor Drill Bit Sharpener offers a powerful motor for smooth operation and Diamond grinding wheel providing long life & constant geometry without the need for wheel dressing. Suitable for sharpening High Speed Steel, Masonry, Tin Coated, Carbide, Cobalt & Parabolic twist drills.

With its adjustable relief angle and the ability to create and sharpen split point bits, the DDXP is a must have for any workshop.

Features

- Adjustable point angle
- Adjustable relief angle
- Creates & restores split point bits
- User replaceable diamond sharpening wheel



Part No.	DDXP
Drill Bit Capacity	2.5mm - 13mm (3/32" to 1/2")
Point Angle	118°
Voltage	240V 1PH

DRILL BIT SHARPENERS - DAREX

DAREX - Manufacturer of the world's leading precision drill sharpeners for industry, offer a range of the highest quality machines for sharpening drills, endmills & countersinks. The outstanding design and construction, offer a precise, fast solution to drill bit sharpening, helping to lower your tool costs, & make those tough jobs run smoothly.

Made In The U.S.A

- **World's Leading Industrial Sharpening Machines**
- **Over 40 Years Of Product Manufacturing, Research And Development**
- **Made In Oregon, U.S.A**

DAREX V391 SHARPENS COMMON POINT STYLES WITH EASE

Accurately sharpen your most common drills in under a minute. The Darex V391 incorporates some of the same technology used in the more advanced machines and is the perfect choice for workshops that need a high quality sharpener. It's simple, intuitive design gives everyone access to sharp drills when you need them.

Features

- Solid steel construction and chuck
- Brass and ball bearing roller guides
- Adjustable split point depth and split point angle
- Adjustable point angles
- Adjustable point relief
- Vacuum port and grit tray
- 75mm Diameter sharpening wheel, designed to sharpen up to 2000 bits
- Supplied with Borazon (CBN) grinding wheel for HSS & Cobalt drills
- Optional diamond sharpening wheel available for sharpening carbide drills

Specifications

- Drill capacity : 3mm - 19mm
- Custom point angles 118° - 140°
- Standard and split point styles
- 240v 1/4hp motor
- Size : 300 x 280 x 230mm
- Weight : 11kg



DAREX XT3000i SHARPENS A WIDE VARIETY OF POINT STYLES WITH PRECISION

The Darex XT3000i is an expandable tool sharpener, capable of sharpening a wide variety of sizes and styles of drills with ease and accuracy. This heavy duty machine has the capacity to sharpen all day, everyday. Attachments can be interchanged in seconds and all adjustments can be made quickly without tools.

Features

- Sharpens standard, and split point HSS & Cobalt drills
- Large range of attachments available to sharpen a range of cutting tools
- Solid steel construction & chucks
- Brass and ball bearing roller guides
- Adjustable split point depth and split point angle
- Adjustable point relief
- Vacuum port and grit tray
- 2 wheels in machine - a sharpening wheel and - a point split wheel (supplied with CBN for high speed steel)
- Optional diamond sharpening wheel available for carbide drills

Specifications

- Sharpens 118°-150° point angles
- Sharpens drill sizes 3 - 21mm (1/8" - 13/16") diameter
- Emerson 1/4 hp motor - 3450 rpm
- Weight : 27kg



DAREX XT3000i AUTO AUTOMATED SHARPENING SYSTEM

Available as an attachment for your XT3000i, or as a complete package system

The XT-3000 is now available as an Automated Sharpening System. This new system allows you to increase productivity by controlled cycle times and pre-drill set up. The XT3000 AUTO makes sharpening drills even easier, simply align the drill, insert the chuck and press start. The LCD screen displays valuable information and can be set to display in 5 different languages. You can purchase the Automated Sharpening system inclusive with a new XT3000i or as an attachment to use with your current XT3000i model.

Features

With all of the features of the XT3000i, plus :

- The grinding process is driven mechanically
- The counter enables accurate overview of costs
- Increased life of the sharpening wheel due to the precise automated action
- Ideal for grinding long length twist drills
- With a second preset chuck, output can be increased significantly

Specifications

- Sharpens standard and split point HSS & Cobalt drills with a point angle of 118° - 150°
- 3 - 21mm (1/8" - 13/16") capacity



DAREX XT3000i ATTACHMENTS

The XT3000i tool sharpener can be expanded with the following attachments, to meet a variety of sharpening requirements. Attachments can be interchanged in seconds and all adjustments can be made without tools.

Part No.	Description	Image
LEX050 LARGE DRILL BIT ATTACHMENT	21-30mm (13/16" - 1-3/16") Drill Attachment. 3 pieces include: sharpening fixture, alignment fixture & chuck.	
LEX100 POSITIONING ATTACHMENT	Radial X - Y Table offers precise positioning of cutting tools. Must be used with either the countersink, step drill or brad point attachments.	
LEX150 COUNTERSINK ATTACHMENT	Single Flute & Cross Hole Countersink Attachment. 6 & 8mm collets Also available: 3 Flute Countersink Cam Part# DAPP16862TF 6 Flute Countersink Cam Part# DAPP16864TF	
LEX200 BRAD POINT DRILL ATTACHMENT	Brad Point Attachment 2 piece attachment includes: sharpening fixture & 3mm - 12mm chuck. *21mm optional chuck available.	
LEX250 STEP DRILL ATTACHMENT	Step Drill Attachment 3 piece attachment includes: 3mm - 12mm chuck, sharpening & alignment fixture. Max pilot size 12mm (1/2"). Max 21mm chuck available	
LEX300 90° POINT ANGLE ATTACHMENT	90° Point Angle Attachment 2 piece attachment includes sharpening fixture & 3mm - 12mm chuck. Optional 12mm - 21mm chuck available.	
LEX350 MINIATURE DRILLS ATTACHMENT	Miniature Drill Sharpening Attachment 2 piece attachment includes drill chuck & CBN Sharpening Wheel. 1.27 - 7mm Capacity.	
LEX500i AUTOMATIC ATTACHMENT	Automatic Grinding Attachment. 4 piece attachment includes LCD Screen control panel, motorised sharpening fixture, 3 - 12mm chuck & 12 - 21mm chuck.	

DAREX XPS16 AUTOMATIC 4-AXIS CNC DRILL SHARPENER

The XPS16 Automatic 4-axis CNC Drill is an extremely accurate work horse for high tech applications. The XPS16 is designed for high production workplaces that demand the ultimate in precision, simplicity and productivity. The XPS-16 can do it all - with the touch of a button. This high capacity machine can sharpen thousands of drills a week. With a touch screen user interface that is simple and easy to learn, everyone in your shop can be using the XPS16 in just a few minutes. Sharpen pre-programmed points, or program your own custom points to suit the drill and specific job requirements. The XPS-16 is the only machine in the world that, with the touch of button, can automatically detect the drill's length and diameter, then sharpen the drill all in one continuous process without operator involvement. For carbide, there's even an automatic cycle to hone the cutting edge. An important step to achieve the long drill life you expect.

Features

- Point styles sharpened: Standard conic, 4-facet, standard split point and radius split point
- Operation mode: Automatic
- Hones carbide drill cutting edges
- Lifetime lubrication seals
- Durable fibre optic sensors measure and size drills
- LCD display panel for one-touch programming
- Long-lasting super-abrasive plated grinding wheels
- Grind motion control monitors load on grinding wheel, adjusts feed and speeds keeping drills cool
- Diagnostic software alerts operators of potential problems
- Vacuum grit removal system which eliminates airborne contaminants

Specifications

- Capacity: 3 to 16 mm (1/8" to 5/8")
- Point angles sharpened: 90° to 150°
- Duty rating: Heavy duty, high capacity
- Machine size: 66 x 56 x 30.5 cm
- Machine weight: 52 kg / vacuum 13 kg
- Sharpening Wheels included: CBN for HSS & cobalt, & diamond for carbide



DAREX E90i MAKES DIFFICULT END-MILL SHARPENING SIMPLE

The E90 End Mill Grinder and Sharpener quickly and easily sharpens a wide range of endmills. Renew endmills up to 52mm in flute diameter and 156mm flute length. Easily sharpen long flute end mills. The easy-pull handle allows precise control of the air-bearing spindle. You can pull and rotate the spindle the full length of the end mill without the necessity of re-positioning your hand. Increase your production. A sharp end mill will allow maximum machining rates as well as generating less heat in the process. Fewer burrs will be created, reducing the time necessary for finishing processes.

Features

- Sharpens 2, 3, 4, & 6 flute End Mills / Slot Drills
- Ideal for: Shops that want to save money by sharpening precision end mills quickly and easily

Specifications

- Grinding capacity: 1.5mm to 52mm (1/16" to 2") flute diameter, 1.5mm to 26mm (1/16" to 1") shank diameter
- Maximum flute length: 156mm (6")
- 240v, 3.2amp, 1/4hp motor, 50hz, 3450rpm
- Resin bonded CBN wheel
- Point angles sharpened: 2° fishtail on the end of the tool
- Uses 5C collets, supplied with a set of 6
- Sharpening Wheel included : Resin-bonded CBN wheel (diamond option for carbide available)



ANNULAR CUTTER SHARPENER

Features

Sharpen high speed steel annular cutters in the simplest possible manner. The robust construction & specific design enable easy operation to sharpen cutters with maximum precision. Laser alignment for fast precise setup.

Specifications

- 240v 1200w motor 2800rpm
- 125mm diamond grinding wheel
- 19mm (Weldon shank) cutter holder
- CBN wheels & gulleting wheels also available
- Supplied with dividing discs for 6, 7, 8, 9 & 10 teeth cutters. Other sizes available on request.



Part No.	Description
HMCS100-2	Holemaker Cutter Sharpening Machine
SPHMCS100-125X10	Sharpening Wheel, Diamond 125 x 10
SPHMCS100-125X10CBN	Sharpening Wheel, CBN 125 x 10
SPHMCS100-125X10G	Gulleting Wheel, Diamond 125 x 10
SPHMCS100-125X10CBNG	Gulleting Wheel, CBN 125 x 10

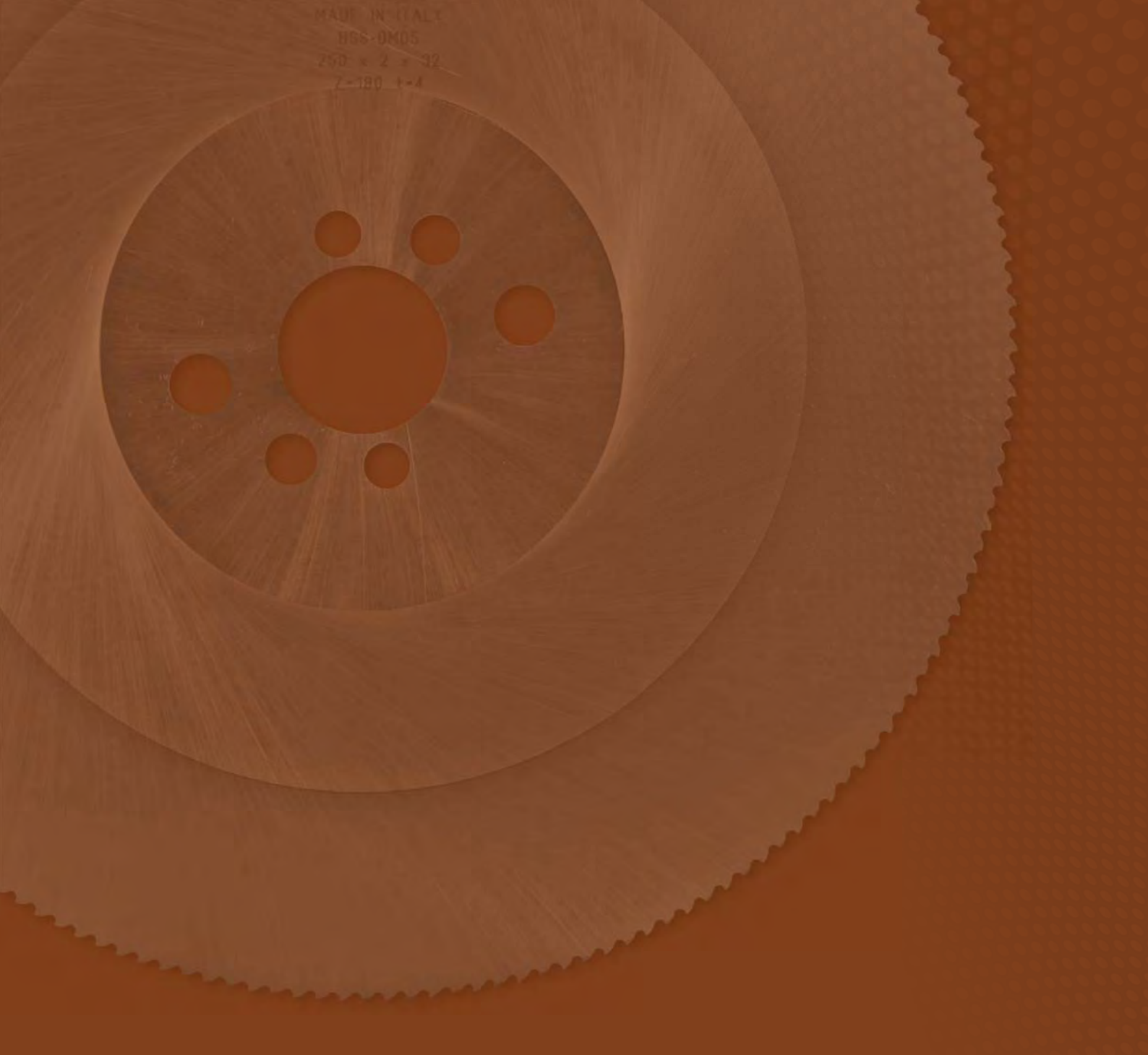

METAL CUTTING SAWS

Coldsaws - MACC	148	Saw Accessories	171
T.C.T. Saws	155	Coldsaw Blades	172
Friction Saws	156	Bandsaw Blades	174
Bandsaws - Trademaster	158	T.C.T. Saw Blades	175
Bandsaws - MACC	166		

MACC

Made in Italy

ITALIAN MADE METAL CUTTING SAWS COLDSAWS • BANDSAWS • FRICTION SAWS • T.C.T. SAWS

WITH OVER 35 YEARS IN THE METAL SAW MANUFACTURING INDUSTRY,
MACC IS INTERNATIONALLY RENOWNED FOR IT'S SUPERIOR
QUALITY AND INNOVATIVE PRODUCT RANGE

- RELIABLE AND HEAVY DUTY, ITALIAN MADE MACHINES
- 26 DIFFERENT MODELS OF METAL CUTTING SAWS,
STOCKED IN AUSTRALIA!





COLDSAWS

K225

225mm SWIVEL HEAD COLDSAW



Features

- Italian made quality
- Swivel head 45° left
- Trigger switch operation
- Quick locking vice
- Incorporated recirculating mechanical coolant system
- Adjustable material stop for repetitive production
- Comes complete with blade
- Blade rotates in an anti-clockwise direction



Part No.	MC-K225-1			
Motor	1HP Single Phase 240V			
Blade Speed	Single Speed 52rpm			
Blade Size	225mm			
Blade Bore	32mm			
Weight	41kg			
CUTTING CAPACITY				
Cutting Angle				
90°	30mm	65mm	55 x 55mm	70 x 45mm
45°	30mm	60mm	50 x 50mm	60 x 40mm

NEW 250 DV

250mm SWIVEL HEAD COLDSAW



Features

- Italian made quality
- Swivel head 45° left & right
- Trigger switch operation
- Quick locking double vice for burr free cutting
- Incorporated recirculating mechanical coolant system
- Adjustable material stop for repetitive production
- Comes complete with blade
- Optional stand available - part# MC-STAND250



Part No.	MC-NEW250DV-1	MC-NEW250DV-3		
Motor	1.2HP Single Phase	1.75HP Three Phase		
Blade Speed	Single Speed 40rpm	2 Speed 40 / 80rpm		
Blade Size	250mm			
Blade Bore	32mm			
Weight	83kg			
CUTTING CAPACITY				
Cutting Angle				
90°	40mm	70mm	70 x 70mm	95 x 55mm
45°	35mm	65mm	55 x 55mm	60 x 50mm



TRS 300 300mm SWIVEL HEAD COLDSAW



Features

- Italian made quality
- Swivel head 45° left & right
- Trigger switch operation
- Quick locking vice with sliding counter vice
- Incorporated recirculating mechanical coolant system
- Adjustable material stop for repetitive production
- Comes complete with blade
- Optional stand available - part# MC-STAND250



Part No.	MC-TRS300-1	MC-TRS300-3		
Motor	2HP Single Phase	3HP Three Phase		
Blade Speed	Single Speed 40rpm	2 Speed 40 / 80rpm		
Blade Size	300mm			
Blade Bore	32mm			
Weight	98kg			
CUTTING CAPACITY				
Cutting Angle	●	○	□	▭
90°	55mm	90mm	90 x 90mm	105 x 70mm
45°	50mm	90mm	80 x 80mm	85 x 70mm

TRS 315 EDV 315mm SWIVEL HEAD COLDSAW



Features

- Italian made quality
- Recirculating coolant system with electric pump
 - Creates instant flow of coolant
 - Flood applied coolant creates a cooler cut, for increased finish quality & blade life
- Swivel head 45° left & right
- Trigger switch operation
- Quick locking double vice for burr free cutting
- Incorporated recirculating mechanical coolant system supplying coolant to both sides of the blade
- Adjustable material stop for repetitive production
- Comes complete with blade
- Optional stand available - part# MC-STAND315



Part No.	MC-TRS315EDV-1	MC-TRS315EDV-3		
Motor	2HP Single Phase	3HP Three Phase		
Blade Speed	Single Speed 40rpm	2 Speed 40 / 80rpm		
Blade Size	315mm			
Blade Bore	32mm			
Weight	165kg			
CUTTING CAPACITY				
Cutting Angle	●	○	□	▭
90°	55mm	90mm	80 x 80mm	115 x 70mm
45°	50mm	80mm	70 x 70mm	70 x 70mm

Magnetic Base Drilling Machines

Cutting Tools

Clamps

Engineer's Tools

Sharpening Machines

Metal Cutting Saws

Drilling Machines

Bevelling Machines & Welding Carriages

Punches & Shears

Grinding Machines

Fans & Ventilators

Workshop Storage

M7 Airtools

NPK Airtools

Pneumatic Products



TRS 315 EDVS 315mm SWIVEL HEAD COLDSAW



Features

- Designed specifically for cutting stainless steel
- Italian made quality
- Recirculating coolant system with electric pump
 - Creates instant flow of coolant
 - Flood applied coolant creates a cooler cut, for increased finish quality & blade life
- Swivel head 45° left & right
- Trigger switch operation
- Quick locking double vice for burr free cutting
- Incorporated recirculating mechanical coolant system supplying coolant to both sides of the blade
- Adjustable material stop for repetitive production
- Comes complete with blade
- Optional stand available - part# MC-STAND315



Part No.	MC-TRS315EDVS-3			
Motor	3HP Three Phase			
Blade Speed	2 Speed 20 / 40rpm			
Blade Size	315mm			
Blade Bore	32mm			
Weight	165kg			
CUTTING CAPACITY				
Cutting Angle				
90°	55mm	90mm	80 x 80mm	115 x 70mm
45°	50mm	80mm	70 x 70mm	70 x 70mm

NEW 315 DV 315mm SWIVEL HEAD COLDSAW



Features

- Italian made quality
- Swivel head 45° left & right
- Trigger switch operation
- Quick locking double vice for burr free cutting
- Blade protection clutch, suitable for cutting profile steels or tube where multiple material thicknesses are being cut in 1 pass. The clutch will protect the cutting teeth and material when passing from the thin easier to cut material into the thick harder to cut material
- Incorporated recirculating mechanical coolant system supplying coolant to both sides of the blade
- Adjustable material stop for repetitive production
- Comes complete with blade
- Optional stand available - part# MC-STAND315



Part No.	MC-NEW315DV-1	MC-NEW315DV-3		
Motor	2HP Single Phase	3HP Three Phase		
Blade Speed	Single Speed 40rpm	2 Speed 40 / 80rpm		
Blade Size	315mm			
Blade Bore	32mm			
Weight	170kg			
CUTTING CAPACITY				
Cutting Angle				
90°	65mm	90mm	85 x 85mm	120 x 70mm
45°	60mm	80mm	70 x 70mm	80 x 70mm



NEW 315 DVS 315mm SWIVEL HEAD COLDSAW



Features

As per NEW315DV with Slow RPM

- Designed specifically for cutting stainless steel
- Italian made quality
- Swivel head 45° left & right
- Trigger switch operation
- Quick locking double vice for burr free cutting
- Blade protection clutch, suitable for cutting profile steels or tube where multiple material thicknesses are being cut in 1 pass. The clutch will protect the cutting teeth and material when passing from the thin easier to cut material into the thick harder to cut material
- Incorporated recirculating mechanical coolant system supplying coolant to both sides of the blade
- Adjustable material stop for repetitive production
- Comes complete with blade
- Optional stand available part# MC-STAND315



Part No.	MC-NEW315DVS-3			
Motor	3HP Three Phase 415V			
Blade Speed	2 Speed Slow 20 / 40rpm			
Blade Size	315mm			
Blade Bore	32mm			
Weight	170kg			
CUTTING CAPACITY				
Cutting Angle				
90°	65mm	90mm	85 x 85mm	120 x 70mm
45°	60mm	80mm	70 x 70mm	80 x 70mm

NEW 315 DPV 315mm SWIVEL HEAD COLDSAW



Features

As per NEW315DV with addition of pneumatic vice

- Vice automatically closes when triggered from foot control
- Italian made quality
- Swivel head 45° left & right
- Trigger switch operation
- Quick locking double vice for burr free cutting
- Blade protection clutch, suitable for cutting profile steels or tube where multiple material thicknesses are being cut in 1 pass. The clutch will protect the cutting teeth and material when passing from the thin easier to cut material into the thick harder to cut material
- Incorporated recirculating mechanical coolant system supplying coolant to both sides of the blade
- Adjustable material stop for repetitive production
- Compressor required to power vice
- Comes complete with blade
- Optional stand available part# MC-STAND315



Part No.	MC-NEW315DPV-1	MC-NEW315DPV-3		
Motor	2HP Single Phase	3HP Three Phase		
Blade Speed	Single Speed 40rpm	2 Speed 40 / 80rpm		
Blade Size	315mm			
Blade Bore	32mm			
Weight	175kg			
CUTTING CAPACITY				
Cutting Angle				
90°	65mm	90mm	85 x 85mm	120 x 70mm
45°	60mm	80mm	70 x 70mm	80 x 70mm

Magnetic Base Drilling Machines

Cutting Tools

Clamps

Engineer's Tools

Sharpening Machines

Metal Cutting Saws

Drilling Machines

Bevelling Machines & Welding Carriages

Punches & Shears

Grinding Machines

Fans & Ventilators

Workshop Storage

M7 Airtools

NPK Airtools

Pneumatic Products



NEW 350 E 350mm SWIVEL HEAD COLDSAW



Features

- Italian made quality
- Recirculating coolant system with electric pump
 - Creates instant flow of coolant
 - Flood applied coolant creates a cooler cut, for increased finish quality & blade life
- Swivel head 45° left & right
- Trigger switch operation
- Quick locking vice with sliding counter vice
- Incorporated recirculating mechanical coolant system supplying coolant to both sides of the blade
- Adjustable material stop for repetitive production
- Comes complete with blade
- Optional stand available - part# MC-STAND315



Part No.	MC-NEW350E-3			
Motor	3.2HP Three Phase 415V			
Blade Speed	2 Speed 20 / 40rpm			
Blade Size	350mm			
Blade Bore	32mm			
Weight	204kg			
CUTTING CAPACITY				
Cutting Angle				
90°	60mm	110mm	100 x 100mm	155 x 80mm
45°	55mm	90mm	85 x 85mm	90 x 85mm

NEW 350 EDV 350mm SWIVEL HEAD COLDSAW



Features

As per NEW350DV with addition of electric coolant pump

- Recirculating coolant system with electric pump
 - Creates instant flow of coolant
 - Flood applied coolant creates a cooler cut, for increased finish quality & blade life
- Italian made quality
- Swivel head 45° left & right
- Trigger switch operation
- Quick locking double vice for burr free cutting
- Adjustable material stop for repetitive production
- Comes complete with blade
- Optional stand available part# MC-STAND315



Part No.	MC-NEW350EDV-3			
Motor	3.2HP Three Phase 415V			
Blade Speed	2 Speed 20 / 40rpm			
Blade Size	350mm			
Blade Bore	32mm			
Weight	210kg			
CUTTING CAPACITY				
Cutting Angle				
90°	60mm	110mm	100 x 100mm	120 x 80mm
45°	55mm	80mm	80 x 80mm	80 x 80mm

NEW 350 DPV 350mm SWIVEL HEAD COLDSAW



Features

As per NEW350DV with addition of pneumatic vice

- Vice automatically closes when triggered from foot control
- Italian made quality
- Swivel head 45° left & right
- Trigger switch operation
- Quick locking double vice for burr free cutting
- Incorporated recirculating mechanical coolant system supplying coolant to both sides of the blade
- Adjustable material stop for repetitive production
- Compressor required to power vice
- Comes complete with blade
- Optional stand available - part# MC-STAND315



Part No.	MC-NEW350DPV-3			
Motor	3.2HP Three Phase 415V			
Blade Speed	2 Speed 20 / 40rpm			
Blade Size	350mm			
Blade Bore	32mm			
Weight	210kg			
CUTTING CAPACITY				
Cutting Angle				
90°	60mm	110mm	100 x 100mm	120 x 80mm
45°	55mm	80mm	80 x 80mm	80 x 80mm

NEW 350 S 350mm SEMI-AUTO SWIVEL HEAD COLDSAW



Features

As per NEW350DV with addition of Semi-Auto Function

Semi-Auto machine performs the following operations automatically during the cutting cycle :

1. vice closes and blade motor starts
 2. cutting head downstroke
 3. return of head and blade motor stop
 4. vice re-opens
- Italian made quality
 - Swivel head 45° left & right
 - Quick locking double vice for burr free cutting
 - Incorporated recirculating mechanical coolant system supplying coolant to both sides of the blade
 - Adjustable material stop
 - Compressor required to power vice
 - Comes complete with blade & stand



Part No.	MC-NEW350S-3			
Motor	3.2HP Three Phase 415V			
Blade Speed	2 Speed 20 / 40rpm			
Blade Size	350mm			
Blade Bore	32mm			
Weight	280kg			
CUTTING CAPACITY				
Cutting Angle				
90°	60mm	110mm	100 x 100mm	120 x 80mm
45°	55mm	80mm	80 x 80mm	80 x 80mm



NTS 315 315mm SEMI-AUTO VERTICAL COLDSAW



Vertical coldsaws offer increased rigidity over standard horizontal coldsaws, decreasing chatter and increasing cut finish quality.

Features

Semi-Auto machine performs the following operations automatically during the cutting cycle :

1. vice closes and blade motor starts
 2. cutting head downstroke
 3. return of head and blade motor stop
 4. vice re-opens
- Italian made quality
 - Swivel head 45° left & 60° right
 - Recirculating coolant system with electric pump
 - Adjustable material stop for repetitive production
 - Compressor required to power vice
 - Comes complete with blade & stand



Part No.	MC-NTS315-3			
Motor	2.5HP Three Phase 415V			
Blade Speed	2 Speed 33 / 66rpm			
Blade Size	315mm			
Blade Bore	32mm			
Weight	300kg			
CUTTING CAPACITY				
Cutting Angle				
90°	70mm	100mm	90 x 90mm	135 x 80mm
45° (L&R)	70mm	100mm	90 x 90mm	100 x 80mm
60° (R)	70mm	80mm	70 x 70mm	80 x 70mm

NTS 370 370mm SEMI-AUTO VERTICAL COLDSAW



Vertical coldsaws offer increased rigidity over standard horizontal coldsaws, decreasing chatter and increasing cut finish quality.

Features

Semi-Auto machine performs the following operations automatically during the cutting cycle:

1. vice closes and blade motor starts
 2. cutting head downstroke
 3. return of head and blade motor stop
 4. vice re-opens
- Italian made quality
 - Swivel head 45° left & right
 - Recirculating coolant system with electric pump
 - Adjustable material stop for repetitive production
 - Material output conveyor
 - Guarded cutting area
 - Comes complete with blade & stand



Part No.	MC-NTS370-3			
Motor	3.4HP Three Phase 415V			
Blade Speed	2 Speed 12 / 25rpm			
Blade Size	370mm			
Blade Bore	32mm			
Weight	500kg			
CUTTING CAPACITY				
Cutting Angle				
90°	100mm	130mm	120 x 120mm	170 x 100mm
45° (L&R)	100mm	130mm	100 x 100mm	140 x 100mm

T.C.T SAWS

TA 400 400mm T.C.T COMPOUND MITRE SAW



Features

- Italian made quality, extra heavy duty
- Compound mitre , non-ferrous metal cutting saw
- Designed for cutting aluminium, copper, brass etc.
- Swivel head 45° right and left
- Mitre head 45° left
- Trigger switch operation
- Twin manual sliding vices with teflon jaws
- Fully recirculating coolant system
- Blade sold separately
- Optional stand available part# MC-STAND315



TA 400 PNEUMATIC 400mm T.C.T COMPOUND MITRE SAW PNEUMATIC



Features

As per TA400, with additional pneumatic features

1. Two pneumatic spring return vices, automatically clamps the material when the trigger switch is pulled
 2. Supply of fluid mist to the blade is also activated
 3. Material is then released upon return of cutting head, & fluid mist de-activated
- Blade sold separately
 - Compressor required to power vice
 - Machine comes complete with stand



Part No.	MC-TA400-3			
Motor	3HP Three Phase 415V			
Blade Speed	Single Speed 3000rpm			
Blade Size	400mm			
Blade Bore	32mm			
Weight	160kg			
CUTTING CAPACITY				
Cutting Angle				
90°	60mm	140mm	110 x 110mm	180 x 100mm
45°	60mm	130mm	100 x 100mm	150 x 100mm

Part No.	MC-TA400P-3			
Motor	3HP Three Phase 415V			
Blade Speed	Single Speed 3000rpm			
Blade Size	400mm			
Blade Bore	32mm			
Weight	195kg			
CUTTING CAPACITY				
Cutting Angle				
90°	60mm	140mm	110 x 110mm	180 x 100mm
45°	60mm	130mm	100 x 100mm	150 x 100mm



FRICTION SAWS

TV 350 350mm SWIVEL HEAD FRICTION SAW



Features

- Italian made quality, extra heavy duty
- Swivel head 45° left & right
- Swivel vice provides complete reverse angle cutting
- Trigger switch operation
- Quick locking vice
- Adjustable material stop for repetitive production
- Emergency stop safety switch
- No blade supplied
- Optional stand available part# MC-STAND250



TV 400 400mm SWIVEL HEAD FRICTION SAW



Features

- Italian made quality, extra heavy duty
- Swivel head 45° left & right
- Swivel vice provides complete reverse angle cutting
- Trigger switch operation
- Quick locking vice
- Adjustable material stop for repetitive production
- Emergency stop safety switch
- No blade supplied
- Optional stand available part# MC-STAND250



Part No.	MC-TV350-3		
Motor	7.4HP Three Phase 415V		
Blade Speed	Single Speed 4300rpm		
Blade Size	350mm		
Blade Bore	25.4mm		
Weight	145kg		
CUTTING CAPACITY			
Cutting Angle	●	■	□
90°	120mm	108 x 108mm	140 x 90mm
45°	105mm	95 x 95mm	100 x 90mm

Part No.	MC-TV400-3		
Motor	7.4HP Three Phase 415V		
Blade Speed	Single Speed 3800rpm		
Blade Size	406mm		
Blade Bore	25.4mm		
Weight	145kg		
CUTTING CAPACITY			
Cutting Angle	●	■	□
90°	130mm	120 x 120mm	170 x 100mm
45°	120mm	100 x 100mm	150 x 100mm

SC406

406mm FRICTION CUT SAW



Features

- Cuts through steel with ease up to 140 x 120mm
- Powerful 5HP 3 Phase Industrial Motor, delivering a clean cut in seconds
- Heavy duty construction, solid cast iron base and all steel guards & shields designed for everyday fabrication purposes
- Heavy duty vise with 90° - 45° adjustment
- NHP industrial switch gear
- Assembly by ITM in Australia
- Dual belt drive with fully enclosed belt guard
- No blade supplied
- Base complete with wheels

Optional fully retractable blade guard available



S14

350mm COLD CUT T.C.T. SAW



Features

- 355mm Tungsten Carbide Tipped blade
- Saves time & money giving cool cuts that need little to no finishing, eliminating any need for grinding or cool down time
- The fully enclosed retractable guard increases user safety
- Heavy duty vise 90° - 45°
- Pipe vise attachment
- Supplied with T.C.T. mild steel blade



Part No.	SC406
Part No.	SC406FG - Retractable Blade Guarded Version
Motor	5HP Three Phase 415V
Blade Speed	4300rpm
Blade Size	406mm
Blade Bore	25.4mm
Weight	75kg
CUTTING CAPACITY	
Cutting Angle	
90°	140 x 120mm
45°	140 x 90mm

Part No.	S14
Motor	3.0HP Single Phase 240V
Blade Speed	Single Speed 1450rpm
Blade Size	355mm
Blade Bore	25.4mm
Weight	29kg
CUTTING CAPACITY	
Cutting Angle	
90°	120 x 120mm
45°	120 x 90mm

BANDSAWS

UE127DV 120MM X 120MM CAPACITY PORTABLE SWIVEL HEAD BANDSAW



Features

- Carry handle and 23kg weight makes this machine ideal for portable use
- Trigger switch operation for making quick cuts
- Variable speed motor for precise cutting of a wide range of materials
- Swivel head enables 0° - 60° mitre cuts
- Adjustable material stop for repetitive production
- Comes complete with blade



Part No.	UE127DV		
Motor	0.4HP (300W) Single Phase (240V)		
Blade Speed	Variable 23-75mpm		
Blade Size	13mm x 0.65mm x 1440mm		
Weight	23kg		
CUTTING CAPACITY			
Cutting Angle	●	■	▬
90°	125mm	120 x 120mm	120 x 120mm
45° Right	77mm	77 x 77mm	120 x 77mm
60° Right	40mm	40 x 40mm	65 x 40mm

RF128 150MM X 115MM CAPACITY PORTABLE BANDSAW



Features

- 3 blade speed 24 / 37 / 61mpm
- Swivel vise enables 0° - 45° mitre cuts
- Adjustable material stop for repetitive production
- Comes complete with stand & blade



Part No.	RF128	
Motor	1/3HP Single Phase (240V)	
Blade Speed	3 Speed 24 / 37 / 61mpm	
Blade Size	12.7mm x 0.65mm x 1635mm	
Bed Height	650mm	
Weight	60kg	
CUTTING CAPACITY		
Cutting Angle	●	▬
90°	128mm	150 x 115mm
45°	76mm	115 x 76mm

RF128HDR 150MM X 128MM CAPACITY PORTABLE 2 WAY SWIVEL HEAD BANDSAW



Features

- 2 Way swivel head enables 0 to 60° mitre cuts both left & right
- Fully adjustable hydraulic down feed with separate on/off valve & automatic shut-off at end of cut
- 3 Blade speeds allows precise cutting of different materials
- Adjustable material stop for repetitive production
- Fitted on base with wheels for easy manoeuvring
- Comes complete with blade



Part No.	RF128HDR	
Motor	1/3HP Single Phase (240V)	
Blade Speed	3 Speed 24 / 37 / 61mpm	
Blade Size	12.7mm x 0.65mm x 1635mm	
Bed Height	710mm	
Weight	78kg	
CUTTING CAPACITY		
Cutting Angle		
90°	128mm	150 x 128mm
45° Right	95mm	95 x 75mm
60° Right	44mm	56 x 44mm

UE712A 300MM X 180MM CAPACITY BANDSAW



Features

- Horizontal & vertical cutting bandsaw
- Quick positioning swivel vise enables cuts from 0° to 45°
- Fully adjustable hydraulic down feed with separate on/off valve & automatic shut-off at end of cut
- Incorporated recirculating coolant system
- Non voltage return ON/OFF switch & emergency stop switch
- 4 Blade speeds allows precise cutting of different materials
- Brass chip brush to help extend blade life
- Adjustable material stop for repetitive production
- Fitted on base with wheels for easy manoeuvring
- Comes complete with blade



RF812 305MM X 178MM CAPACITY BANDSAW



Features

- Quick positioning swivel vise enables cuts from 0° to 45°
- Fully adjustable hydraulic down feed with separate on/off valve & automatic shut-off at end of cut
- Incorporated recirculating coolant system
- Non voltage return ON/OFF switch & emergency stop switch
- 4 Blade speeds allows precise cutting of different materials
- Brass chip brush to help extend blade life
- Adjustable material stop for repetitive production
- Fitted on base with wheels for easy manoeuvring
- Comes complete with blade



Part No.	UE712A	
Motor	1.0HP Single Phase (240V)	
Blade Speed	4 Speed 22 / 33 / 45 / 65mpm	
Blade Size	19mm x 0.9mm x 2360mm	
Bed Height	572mm	
Weight	130kg	
CUTTING CAPACITY		
Cutting Angle		
90°	180mm	300 x 180mm
45°	110mm	

Part No.	RF812	
Motor	3/4hp Single Phase	
Blade Speed	4 Speed 27 / 41 / 59 / 78mpm	
Blade Size	20mm x 0.8mm x 2362mm	
Bed Height	545mm	
Weight	150kg	
CUTTING CAPACITY		
Cutting Angle		
90°	200mm	305 x 178mm
45°	127mm	125 x 120mm

WE200SV

200MM X 85MM CAPACITY
SWIVEL HEAD BANDSAW



Features

- Swivel head enables 0° to 60° mitre cuts
- Trigger switch operation for making quick cuts
- Variable speed motor for precise cutting of a range of materials
- Incorporated recirculating coolant system
- Adjustable material stop for repetitive production
- Comes complete with stand & blade

Optional

- Brass chip brush
- Blade tension gauge



Part No.	WE200SV		
Motor	1.5HP Single Phase DC (240V) Variable Speed		
Blade Speed	Variable 25-85mpm		
Blade Size	19mm x 0.9mm x 2110mm		
Bed Height	895mm		
Weight	154kg		
CUTTING CAPACITY			
Cutting Angle			
90°	165mm	160 x 160mm	200 x 85mm
45° Right	125mm	120 x 120mm	
60° Right	70mm	60 x 60mm	

WP210SH

170MM X 170MM CAPACITY
SWIVEL HEAD BANDSAW



Features

- Swivel head enables 0° to 60° mitre cuts
- Dual mode operation
 - Trigger switch with manual downfeed for small quick cuts
 - Control panel with fully adjustable hydraulic down feed & automatic shut-off at end of cut, for cutting larger material
- Incorporated recirculating coolant system
- Adjustable material stop for repetitive production
- Comes complete with stand & blade

Optional

- Brass chip brush
- Blade tension gauge



Part No.	WP210SH-1	WP210SH-3	
Motor	1.0HP Single Phase	1.0HP Three Phase	
Blade Speed	Single Speed 80mpm	2 Speed 40 / 80mpm	
Blade Size	19mm x 0.9mm x 2110mm		
Bed Height	895mm		
Weight	156kg		
CUTTING CAPACITY			
Cutting Angle			
90°	170mm	170 x 170mm	210 x 95mm
45° Right	120mm	110 x 110mm	
60° Right	70mm	60 x 60mm	

Magnetic Base Drilling Machines

Cutting Tools

Clamps

Engineer's Tools

Sharpening Machines

Metal Cutting Saws

Drilling Machines

Bevelling Machines & Welding Carriages

Punches & Shears

Grinding Machines

Fans & Ventilators

Workshop Storage

M7 Airtools

NPK Airtools

Pneumatic Products

WP210SHV

170MM X 170MM CAPACITY
SWIVEL HEAD BANDSAW



Features

- Swivel head enables 0° to 60° mitre cuts
- Variable speed motor for cutting a wide range of materials
- Dual mode operation
 - Trigger switch with manual downfeed for small quick cuts
 - Control panel with fully adjustable hydraulic down feed & automatic shut-off at end of cut, for cutting larger material
- Incorporated recirculating coolant system
- Adjustable material stop for repetitive production
- Comes complete with stand & blade

Optional

- Brass chip brush
- Blade tension gauge



WP270SHV

220MM X 220MM CAPACITY
SWIVEL HEAD BANDSAW



Features

- Swivel head enables 0° to 60° mitre cuts
- Variable speed motor for cutting a wide range of materials
- Dual mode operation
 - Trigger switch with manual downfeed for small quick cuts
 - Control panel with fully adjustable hydraulic down feed & automatic shut-off at end of cut, for cutting larger material
- Incorporated recirculating coolant system
- Brass chip brush to help prevent blade breakage
- Adjustable material stop for repetitive production
- Comes complete with stand & blade

Optional

- Blade tension gauge



Part No.	WP210SHV-1		
Motor	1.0HP Single Phase		
Blade Speed	Variable 20-85mpm		
Blade Size	19mm x 0.9mm x 2110mm		
Bed Height	895mm		
Weight	156kg		
CUTTING CAPACITY			
Cutting Angle			
90°	170mm	170 x 170mm	210 x 95mm
45° Right	120mm	110 x 110mm	
60° Right	70mm	60 x 60mm	

Part No.	WP270SHV-1		
Motor	1.5HP Single Phase		
Blade Speed	Variable 20-85mpm		
Blade Size	27mm x 0.9mm x 2460mm		
Bed Height	885mm		
Weight	216kg		
CUTTING CAPACITY			
Cutting Angle			
90°	227mm	220 x 220mm	260 x 110mm
45° Right	150mm	145 x 145mm	200 x 145mm
60° Right	90mm	85 x 85mm	

WP270SH

220MM X 220MM CAPACITY
SWIVEL HEAD BANDSAW



Features

- Swivel head enables 0° to 60° mitre cuts
- Dual mode operation
 - Trigger switch with manual downfeed for small quick cuts
 - Control panel with fully adjustable hydraulic down feed & automatic shut-off at end of cut, for cutting larger material
- Incorporated recirculating coolant system
- Brass chip brush to help prevent blade breakage
- Adjustable material stop for repetitive production
- Comes complete with stand & blade

Optional

- Blade tension gauge



RF270DR

240MM X 160MM CAPACITY
2 WAY SWIVEL HEAD BANDSAW



Features

- 2 Way swivel head enables 0° to 60° mitre cuts
- Control panel with advanced, heavy duty fully adjustable hydraulic down feed
- Automatic shut-off at end of cut
- Dual direction heavy duty vice
- Hydraulic blade tension gauge
- Incorporated recirculating coolant system
- Brass chip brush to help prevent blade breakage
- Adjustable material stop for repetitive production
- Comes complete with stand & blade



Part No.	WP270SH-1	WP270SH-3	
Motor	1.5HP Single Phase	1.5HP Three Phase	
Blade Speed	Single Speed 72mpm	2 Speed 36 / 72mpm	
Blade Size	27mm x 0.9mm x 2460mm		
Bed Height	885mm		
Weight	216kg		
CUTTING CAPACITY			
Cutting Angle			
90°	227mm	220 x 220mm	260 x 110mm
45° Right	150mm	145 x 145mm	200 x 145mm
60° Right	90mm	85 x 85mm	

Part No.	RF270DR-1	RF270DR-3	
Motor	1.5HP Single Phase	1.5HP Three Phase	
Blade Speed	Single Speed 48mpm	2 Speed 35 / 70mpm	
Blade Size	27mm x 0.9mm x 2450mm		
Bed Height	975mm		
Weight	320kg		
CUTTING CAPACITY			
Cutting Angle			
90°	225mm	200 x 200mm	240 x 160mm
45° Right	145mm	140 x 140mm	145 x 100mm
60° Right	90mm	85 x 85mm	85 x 100mm
45° Left	145mm	120 x 120mm	145 x 90mm

RF270DRV

240MM X 160MM CAPACITY

2 WAY SWIVEL HEAD BANDSAW



Features

- 2 Way swivel head enables 0° to 60° mitre cuts
- Variable speed motor for cutting a wide range of materials
- Control panel with advanced, heavy duty fully adjustable hydraulic down feed
- Automatic shut-off at end of cut
- Dual direction heavy duty vice
- Hydraulic blade tension gauge
- Incorporated recirculating coolant system
- Brass chip brush to help prevent blade breakage
- Adjustable material stop for repetitive production
- Comes complete with stand & blade



Part No.	RF270DRV-1	RF270DRV-3	
Motor	1.5HP Single Phase	1.52HP Three Phase	
Blade Speed	Variable 35-70mpm	Variable 35-70mpm	
Blade Size	27mm x 0.9mm x 2450mm		
Bed Height	975mm		
Weight	320kg		
CUTTING CAPACITY			
Cutting Angle			
90°	225mm	200 x 200mm	240 x 160mm
45° Right	145mm	140 x 140mm	145 x 100mm
60° Right	90mm	85 x 85mm	85 x 100mm
45° Left	145mm	120 x 120mm	145 x 90mm

WP275DS

220MM X 220MM CAPACITY

2 WAY SWIVEL HEAD BANDSAW



Features

- 2 Way swivel head enables 0° to 60° mitre cuts
- Dual mode operation
 - Trigger switch with manual downfeed for small quick cuts
 - Control panel with fully adjustable hydraulic down feed & automatic shut-off at end of cut, for cutting larger material
- Dual direction heavy duty vice
- Incorporated recirculating coolant system
- Brass chip brush to help prevent blade breakage
- Adjustable material stop for repetitive production
- Comes complete with stand & blade

Optional

- Blade tension gauge



Part No.	WP275DS-1	WP275DS-3	
Motor	1.5HP Single Phase	1.5HP Three Phase	
Blade Speed	Single Speed 72mpm	2 Speed 36 / 72mpm	
Blade Size	27mm x 0.9mm x 2460mm		
Bed Height	900mm		
Weight	285kg		
CUTTING CAPACITY			
Cutting Angle			
90°	227mm	220 x 220mm	260 x 110mm
45° Right	150mm	145 x 145mm	200 x 125mm
60° Right	90mm	85 x 85mm	
45° Left	110mm	110 x 110mm	160 x 110mm

Magnetic Base Drilling Machines

Cutting Tools

Clamps

Engineer's Tools

Sharpening Machines

Metal Cutting Saws

Drilling Machines

Bevelling Machines & Welding Carriages

Punches & Shears

Grinding Machines

Fans & Ventilators

Workshop Storage

M7 Airtools

NPK Airtools

Pneumatic Products

WP275DSV

220MM X 220MM CAPACITY
2 WAY SWIVEL HEAD BANDSAW



Features

- 2 Way swivel head enables 0 °to 60° mitre cuts
- Variable speed motor for cutting a wide range of materials
- Dual mode operation
 - Trigger switch with manual downfeed for small quick cuts
 - Control panel with fully adjustable hydraulic down feed & automatic shut-off at end of cut, for cutting larger material
- Dual direction heavy duty vice
- Incorporated recirculating coolant system
- Brass chip brush to help prevent blade breakage
- Adjustable material stop for repetitive production
- Comes complete with stand & blade

Optional

- Blade tension gauge



Part No.	WP275DSV-1		
Motor	1.5HP Single Phase		
Blade Speed	Variable 20-85mpm		
Blade Size	27mm x 0.9mm x 2460mm		
Bed Height	900mm		
Weight	285kg		
CUTTING CAPACITY			
Cutting Angle			
90°	227mm	220 x 220mm	260 x 110mm
45° Right	150mm	145 x 145mm	200 x 125mm
60° Right	90mm	85 x 85mm	
45° Left	110mm	110 x 110mm	160 x 110mm

WP310DS 310MM X 210MM CAPACITY 2 WAY SWIVEL HEAD BANDSAW



Features

- 2 Way swivel head enables 0° to 60° mitre cuts
- Dual mode operation
 - Trigger switch with manual downfeed for small quick cuts
 - Control panel with fully adjustable hydraulic down feed & automatic shut-off at end of cut, for cutting larger material
- Variable speed motor for cutting a wide range of materials
- Dual direction heavy duty vise
- Hydraulic blade tension gauge
- Incorporated recirculating coolant system
- Brass chip brush to help prevent blade breakage
- Adjustable material stop for repetitive production
- Comes complete with stand & blade



Part No.	WP310DS		
Motor	2.0HP Three Phase (415V)		
Blade Speed	2 Speed 36 / 72mpm		
Blade Size	27mm x 0.9mm x 2725mm		
Bed Height	895mm		
Weight	302kg		
CUTTING CAPACITY			
Cutting Angle			
90°	250mm	240 x 240mm	310 x 210mm
45° Right	200mm	180 x 180mm	200 x 140mm
60° Right	120mm	95 x 95mm	120 x 95mm
45° Left	150mm	150 x 150mm	170 x 90mm

RF320HB 310MM X 230MM CAPACITY 2 WAY SWIVEL HEAD BANDSAW



Features

- 2 Way swivel head enables 0° to 60° mitre cuts
- Control panel with advanced, heavy duty fully adjustable hydraulic down feed
- Automatic shut-off at end of cut
- Dual direction heavy duty vise
- Hydraulic blade tension gauge
- Incorporated recirculating coolant system
- Brass chip brush to help prevent blade breakage
- Adjustable material stop for repetitive production
- Comes complete with stand & blade



Part No.	RF320HB-1	RF320HB-3	
Motor	1.5hp Single Phase	1.5hp Three Phase	
Blade Speed	Single Speed 44mpm	Variable 36-73mpm	
Blade Size	27mm x 0.9mm x 2750mm		
Bed Height	975mm		
Weight	315kg		
CUTTING CAPACITY			
Cutting Angle			
90°	255mm	240 x 240mm	310 x 230mm
45° Right	200mm	190 x 190mm	120 x 180mm
60° Right	115mm	115 x 115mm	115 x 115mm
45° Left	170mm	160 x 160mm	180 x 120mm

WE350DS 350MM X 220MM CAPACITY 2 WAY SWIVEL HEAD BANDSAW



Features

- 2 Way swivel head enables 0° to 60° mitre cuts
- Dual mode operation
 - Trigger switch with manual downfeed for small quick cuts
 - Control panel with fully adjustable hydraulic down feed & automatic shut-off at end of cut, for cutting larger material
- 2 speed motor 34 / 68mpm
- Dual direction heavy duty vise
- Hydraulic blade tension gauge
- Incorporated recirculating coolant system
- Brass chip brush to help prevent blade breakage
- Adjustable material stop for repetitive production
- Comes complete with stand & blade



Part No.	WE350DS		
Motor	2.0HP Three Phase (415V)		
Blade Speed	2 Speed 34 / 68mpm		
Blade Size	27mm x 0.9mm x 3160mm		
Bed Height	890mm		
Weight	410kg		
CUTTING CAPACITY			
Cutting Angle			
90°	270mm	260 x 260mm	350 x 220mm
45° Right	240mm	220 x 220mm	240 x 160mm
60° Right	160mm	150 x 150mm	
45° Left	210mm	180 x 180mm	180 x 180mm

WE350DSA 350MM X 220MM CAPACITY SEMI-AUTO 2 WAY SWIVEL HEAD BANDSAW



Features

- 2 Way swivel head enables 0° to 60° mitre cuts
- Semi automatic machine
- Dual direction heavy duty vise
- Hydraulic blade tension gauge
- Incorporated recirculating coolant system
- Brass chip brush to help prevent blade breakage
- Adjustable material stop for repetitive production
- Remote emergency stop non voltage return safety switch
- Comes complete with stand & blade



Semi-Automatic Function

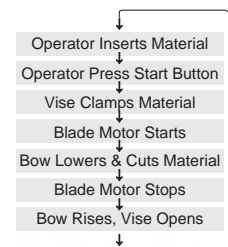

Part No.	WE350DSA		
Motor	2.0HP Three Phase (415V)		
Blade Speed	2 Speed 34 / 68mpm		
Blade Size	27mm x 0.9mm x 3160mm		
Bed Height	890mm		
Weight	530kg		
CUTTING CAPACITY			
Cutting Angle			
90°	270mm	260 x 260mm	350 x 220mm
45° Right	240mm	220 x 220mm	240 x 160mm
60° Right	160mm	150 x 150mm	
45° Left	210mm	180 x 180mm	180 x 180mm



SPECIAL 280CSO
250MM X 155MM CAPACITY
SWIVEL HEAD BANDSAW



Features

- Italian made quality
- Swivel head enables 0° to 60° mitre cuts
- Dual mode operation
 - Trigger switch with manual downfeed for small quick cuts
 - Control panel with fully adjustable hydraulic down feed & automatic shut-off at end of cut, for cutting larger material
- Incorporated recirculating coolant system
- Adjustable material stop for repetitive production
- Comes complete with stand & blade



Part No.	MB-280CSO-1	MB-280CSO-3	
Motor	1.5HP Single Phase	1.5HP Three Phase	
Blade Speed	1 Speed 64mpm	2 Speed 32 - 66mpm	
Blade Size	27mm x 0.9mm x 2450mm		
Weight	230kg		
CUTTING CAPACITY			
Cutting Angle			
90°	220mm	215 x 215mm	250 x 155mm
45°	160mm	150 x 150mm	160 x 110mm
60°	100mm	85 x 85mm	95 x 80mm

SPECIAL 320CSO
300MM X 170MM CAPACITY
SWIVEL HEAD BANDSAW



Features

- Italian made quality
- Swivel head enables 0° to 60° mitre cuts
- Dual mode operation
 - Trigger switch with manual downfeed for small quick cuts
 - Control panel with fully adjustable hydraulic down feed & automatic shut-off at end of cut, for cutting larger material
- Incorporated recirculating coolant system
- Adjustable material stop for repetitive production
- Comes complete with stand & blade



Part No.	MB-320CSO-1	MB-320CSO-3	
Motor	1.5HP Single Phase	1.5HP Three Phase	
Blade Speed	1 Speed 69mpm	2 Speed 35 - 71mpm	
Blade Size	27mm x 0.9mm x 2825mm		
Weight	240kg		
CUTTING CAPACITY			
Cutting Angle			
90°	230mm	220 x 220mm	300 x 170mm
45°	200mm	180 x 180mm	230 x 180mm
60°	130mm	120 x 120mm	130 x 110mm



SPECIAL 320MS
300MM X 170MM CAPACITY
SEMI-AUTO SWIVEL HEAD BANDSAW



Features

- Italian made quality
- Swivel head enables 0° to 60° mitre cuts
- Dual mode operation
 - Trigger switch with manual downfeed for small quick cuts
 - Semi-automatic function for large production type jobs
- Incorporated recirculating coolant system
- Adjustable material stop for repetitive production
- Comes complete with stand & blade

Semi-Automatic Function



Part No.	MB-320MS-3		
Motor	1.5HP Three Phase (415V)		
Blade Speed	2 Speed 35 / 71mpm		
Blade Size	27mm x 0.9mm x 2825mm		
Weight	390kg		
CUTTING CAPACITY			
Cutting Angle			
90°	230mm	220 x 220mm	300 x 170mm
45°	200mm	180 x 180mm	230 x 180mm
60°	130mm	120 x 120mm	130 x 110mm

Magnetic Base Drilling Machines

Cutting Tools

Clamps

Engineer's Tools

Sharpening Machines

Metal Cutting Saws

Drilling Machines

Bevelling Machines & Welding Carriages

Punches & Shears

Grinding Machines

Fans & Ventilators

Workshop Storage

M7 Airtools

NPK Airtools

Pneumatic Products





SPECIAL 330CSO
330MM X 220MM CAPACITY
2 WAY SWIVEL HEAD BANDSAW



Features

- Italian made quality
- 2 Way swivel head enables 0° to 60° mitre cuts
- Dual mode operation
 - Trigger switch with manual downfeed for small quick cuts
 - Control panel with fully adjustable hydraulic down feed & automatic shut-off at end of cut, for cutting larger material
- Dual direction heavy duty vice
- Incorporated recirculating coolant system
- Adjustable material stop for repetitive production
- Comes complete with stand & blade

SPECIAL 330MS
330MM X 220MM CAPACITY
SEMI-AUTO 2 WAY SWIVEL HEAD BANDSAW



Features

- Italian made quality
- 2 Way swivel head enables 0° to 60° mitre cuts
- Dual mode operation
 - Trigger switch with manual downfeed for small quick cuts
 - Semi-automatic function for large production type jobs
- Dual direction heavy duty vice
- Incorporated recirculating coolant system
- Adjustable material stop for repetitive production
- Comes complete with stand & blade

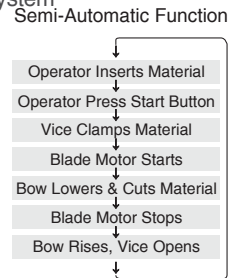

Part No.	MB-330CSO-1	MB-330CSO-3	
Motor	1.5HP Single Phase	1.5HP Three Phase	
Blade Speed	Single Speed 75mpm	2 Speed 38 / 78mpm	
Blade Size	27mm x 0.9mm x 3010mm		
Weight	365kg		
CUTTING CAPACITY			
Cutting Angle			
90°	260mm	250 x 250mm	330 x 220mm
45° Right	225mm	210 x 210mm	225 x 160mm
60° Right	130mm	130 x 130mm	140 x 130mm
45° Left	215mm	200 x 200mm	210 x 160mm

Part No.	MB-330MS-3		
Motor	1.5HP Three Phase (415V)		
Blade Speed	2 Speed 38 / 78mpm		
Blade Size	27mm x 0.9mm x 3010mm		
Weight	415kg		
CUTTING CAPACITY			
Cutting Angle			
90°	260mm	250 x 250mm	330 x 220mm
45° Right	225mm	210 x 210mm	225 x 160mm
60° Right	130mm	130 x 130mm	140 x 130mm
45° Left	215mm	200 x 200mm	210 x 160mm

SPECIAL 411CSO
400MM X 200MM CAPACITY
2 WAY SWIVEL HEAD BANDSAW



Features

- Italian made quality
- 2 Way swivel head enables 0° to 60° mitre cuts
- Dual mode operation
 - Trigger switch with manual downfeed for small quick cuts
 - Control panel with fully adjustable hydraulic down feed & automatic shut-off at end of cut, for cutting larger material
- Dual direction heavy duty vice
- Incorporated recirculating coolant system
- Adjustable material stop for repetitive production
- Comes complete with stand & blade

SPECIAL 411MS
400MM X 200MM CAPACITY
2 WAY SEMI-AUTO SWIVEL HEAD BANDSAW



Features

- Italian made quality
- 2 Way swivel head enables 0° to 60° mitre cuts
- Dual mode operation
 - Trigger switch with manual downfeed for small quick cuts
 - Semi-Automatic function for large production type jobs
- Dual direction heavy duty vice
- Incorporated recirculating coolant system
- Adjustable material stop for repetitive production
- Comes complete with stand & blade

Semi-Automatic Function

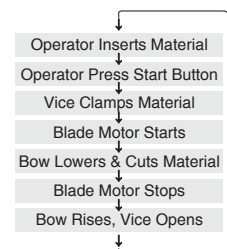

Part No.	MB-411CSO-3		
Motor	2HP Three Phase (415V)		
Blade Speed	2 Speed 38 / 77mpm		
Blade Size	27mm x 0.9mm x 3200mm		
Weight	530kg		
CUTTING CAPACITY			
Cutting Angle			
90°	300mm	280 x 280mm	400 x 200mm
45° Right	240mm	220 x 220mm	240 x 130mm
60° Right	140mm	140 x 140mm	140 x 140mm
45° Left	180mm	160 x 160mm	180 x 110mm

Part No.	MB-411MS-3		
Motor	2HP Three Phase (415V)		
Blade Speed	2 Speed 38 / 77mpm		
Blade Size	27mm x 0.9mm x 3200mm		
Weight	575kg		
CUTTING CAPACITY			
Cutting Angle			
90°	300mm	280 x 280mm	400 x 200mm
45° Right	240mm	220 x 220mm	240 x 130mm
60° Right	140mm	140 x 140mm	140 x 140mm
45° Left	180mm	160 x 160mm	180 x 110mm



SPECIAL 420 DI
550MM X 400MM CAPACITY
2 WAY SEMI-AUTO SWIVEL HEAD BANDSAW



Features

- Italian made quality
- 2 Way swivel head enables 0° to 60° mitre cuts
- Semi-automatic machine
- Dual direction heavy duty vice
- Incorporated recirculating coolant system
- Adjustable material stop for repetitive production
- Comes complete with stand & blade

Semi-Automatic Function

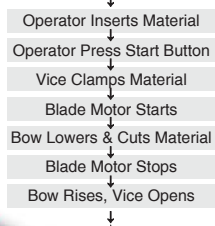

SPECIAL 650 DI
620MM X 450MM CAPACITY
2 WAY SEMI-AUTO SWIVEL HEAD BANDSAW



Features

- Italian Made Quality
- 2 Way Swivel Head enables 0° to 60° mitre cuts
- Semi-automatic machine
- Dual direction heavy duty hydraulic vice
- Incorporated recirculating coolant system
- High capacity variable speed control motor with inverter
- Electro-mechanical blade tensioner
- Comes complete with stand & blade

Semi-Automatic Function

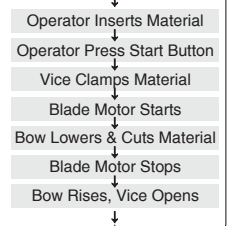

Part No.	MB-420DI-3		
Motor	2HP Three Phase (415V)		
Blade Speed	2 Speed 37 / 75mpm		
Blade Size	34mm x 1.1mm x 4610mm		
Weight	820kg		

CUTTING CAPACITY			
Cutting Angle			
90°	400mm	400 x 400mm	550 x 400mm
45° Right	400mm	380 x 380mm	410 x 300mm
60° Right	280mm	280 x 280mm	400 x 280mm
45° Left	400mm	380 x 380mm	420 x 300mm
60° Left	260mm	260 x 260mm	400 x 230mm

Part No.	MB-650DI-3		
Motor	2.95HP Three Phase (415V)		
Blade Speed	Variable 23-95mpm		
Blade Size	34mm x 1.1mm x 5270mm		
Weight	1250kg		

CUTTING CAPACITY			
Cutting Angle			
90°	460mm	450 x 450mm	620 x 450mm
45° Right	450mm	430 x 430mm	450 x 400mm
60° Right	300mm	300 x 300mm	270 x 420mm
45° Left	450mm	410 x 410mm	450 x 340mm
60° Left	240mm	300 x 300mm	320 x 220mm



SPECIAL 702 GA
700MM X 550MM CAPACITY
2 WAY SEMI-AUTO SWIVEL DUAL COLUMN BANDSAW



Features

- Italian Made Quality
- Dual column for accuracy and rigidity
- Automatic motorised 2 way swivel
- Semi automatic programmable operation
- High capacity variable speed control motor with inverter
- Electro-mechanical blade tensioner
- Comes complete with stand & blade

Semi-Automatic Function

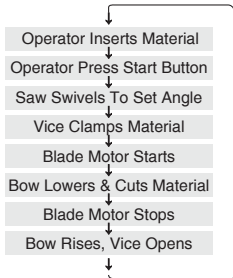

Part No.	MB-702GA-3		
Motor	5.36HP Three Phase (415V)		
Blade Speed	Variable 0 - 90mpm		
Blade Size	41mm x 1.3mm x 6380mm		
Bed Height	735mm		
Weight	2740kgs		
CUTTING CAPACITY			
Cutting Angle			
90°	550mm	550 x 550mm	700 x 550mm
45° Right	470mm	470 x 470mm	550 x 470mm
45° Left	450mm	450 x 450mm	550 x 450mm
60° Left	250mm	250 x 250mm	550 x 250mm

- Magnetic Base Drilling Machines
- Cutting Tools
- Clamps
- Engineer's Tools
- Sharpening Machines
- Metal Cutting Saws**
- Drilling Machines
- Bevelling Machines & Welding Carriages
- Punches & Shears
- Grinding Machines
- Fans & Ventilators
- Workshop Storage
- M7 Airtools
- NPK Airtools
- Pneumatic Products





SPECIAL 380A
320MM X 290MM CAPACITY
FULLY AUTOMATIC SWIVEL HEAD BANDSAW



Features

- Fully-automatic CNC controlled machine
- Swivel head 0° - 60°
- 9 Programs, each with 99 steps
- Digital control of quality and cut length
- 600mm material feeder stroke - no length limit
- Blade cleaning device and washdown hose
- Recirculating coolant system
- Comes complete with stand and blade

Part No.	MB-380A-3		
Motor	2.15HP Three Phase 415V		
Blade Speed	2 Speed 38 / 77 mpm		
Blade Size	3010mm x 27mm x 0.9mm		
Bed Height	850mm		
Weight	960kg		

CUTTING CAPACITY			
Cutting Angle	●	■	▭
90°	290mm	290 x 290mm	320 x 290mm
45° Right	265mm	265 x 265mm	220 x 220mm
60° Right	130mm	130 x 130mm	130 x 130mm

Optional Configurations

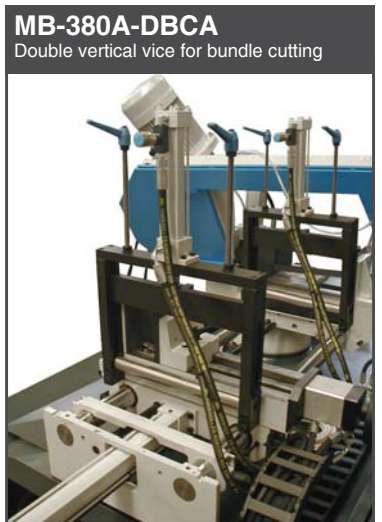

Magnetic Base Drilling Machines
 Cutting Tools
 Clamps
 Engineer's Tools
 Sharpening Machines
 Metal Cutting Saws
 Drilling Machines
 Beveling Machines & Welding Carriages
 Punches & Shears
 Grinding Machines
 Fans & Ventilators
 Workshop Storage
 M7 Airtools
 NPK Airtools
 Pneumatic Products

SAW ACCESSORIES

CONVEYORS



Conveyor lengths and stands sold separately
ITM recommends 3 stands per conveyor

Part No.	Roller Width	Length	Roller Diameter	Number Of Rollers	Capacity Per Roller
RS300X15	300mm	1500mm	50mm	12	150kg
RS300X3	300mm	3000mm	50mm	24	150kg
RS450X15	450mm	1500mm	50mm	12	120kg
RS450X3	450mm	3000mm	50mm	24	120kg
RS600X3	600mm	3000mm	60mm	20	180kg

STANDS

Part No.	Width	Adjustable Height
RS300	300mm	715mm - 1050mm
RS450	450mm	715mm - 1050mm
RS600	600mm	715mm - 1050mm

ACCESSORIES

Part No.	Description
RS-STOP300	Fixed Stop 300mm
RS-STOP450	Fixed Stop 450mm
RS-STOP600	Fixed Stop 600mm
RS-ROLLER300	Individual Roller 300mm
RS-ROLLER450	Individual Roller 450mm
RS-ROLLER600	Individual Roller 600mm
RS-JOINER	Joiner Kit, Joins 2 Conveyors

SINGLE ROLLER CONVEYORS



Part No.	Roller Width	Adjustable Height	Roller Diameter	Number Rollers	Weight Capacity
RS-002	352mm	580 - 980mm	51mm	1	800kg
RS-005	128mm	560 - 960mm	51mm	2	800kg

COLDSAW STANDS



Part No.	Description
MC-STAND250	MACC Small Saw Stand
MC-STAND315	MACC Large Saw Stand



COLDSAW BLADES

HIGH SPEED STEEL - DM05 (M2)

Suitable for general purpose steel cutting



Part No.	Diameter	Thickness	Bore	# Teeth
C1601025-080	160mm	1.0mm	25mm	80
C2001832-100	200mm	1.8mm	32mm	100
C2251932-140	225mm	1.9mm	32mm	140
C2251932-180	225mm	1.9mm	32mm	180
C2252032-152VP	225mm	2.0mm	32mm	152VP
C2252032-180	225mm	2.0mm	32mm	180
C2252032-220	225mm	2.0mm	32mm	220
C2252032-HOSE	225mm	2.0mm	32mm	KNIFE
C2502032-120	250mm	2.0mm	32mm	120
C2502032-128	250mm	2.0mm	32mm	128
C2502032-140	250mm	2.0mm	32mm	140
C2502032-160	250mm	2.0mm	32mm	160
C2502032-172VP	250mm	2.0mm	32mm	172VP
C2502032-180	250mm	2.0mm	32mm	180
C2502032-200	250mm	2.0mm	32mm	200
C2502032-220	250mm	2.0mm	32mm	220
C2502032-250	250mm	2.0mm	32mm	250
C2502040-160	250mm	2.0mm	40mm	160
C2502040-180	250mm	2.0mm	40mm	180
C2502040-220	250mm	2.0mm	40mm	220
C2752032-120	275mm	2.0mm	32mm	120
C2752032-140	275mm	2.0mm	32mm	140
C2752040-140	275mm	2.0mm	40mm	140
C2752040-160	275mm	2.0mm	40mm	160
C2752040-180	275mm	2.0mm	40mm	180
C2752040-200	275mm	2.0mm	40mm	200
C2752040-220	275mm	2.0mm	40mm	220
C2752532-140	275mm	2.5mm	32mm	140
C2752532-180	275mm	2.5mm	32mm	180
C2752532-184VP	275mm	2.5mm	32mm	184VP
C2752532-220	275mm	2.5mm	32mm	220
C2752540-140	275mm	2.5mm	40mm	140
C2752540-180	275mm	2.5mm	40mm	180
C2752540-220	275mm	2.5mm	40mm	220

Part No.	Diameter	Thickness	Bore	# Teeth
C3002532-140	300mm	2.5mm	32mm	140
C3002532-160	300mm	2.5mm	32mm	160
C3002532-180	300mm	2.5mm	32mm	180
C3002532-200	300mm	2.5mm	32mm	200
C3002532-220	300mm	2.5mm	32mm	220
C3002532-250	300mm	2.5mm	32mm	250
C3002532-300	300mm	2.5mm	32mm	300
C3002538-140	300mm	2.5mm	38mm	140
C3002538-160	300mm	2.5mm	38mm	160
C3002538-180	300mm	2.5mm	38mm	180
C3002538-200	300mm	2.5mm	38mm	200
C3002538-220	300mm	2.5mm	38mm	220
C3002540-160	300mm	2.5mm	40mm	160
C3002540-180	300mm	2.5mm	40mm	180
C3002540-200	300mm	2.5mm	40mm	200
C3002540-220	300mm	2.5mm	40mm	220
C3152532-140	315mm	2.5mm	32mm	140
C3152532-160	315mm	2.5mm	32mm	160
C3152532-180	315mm	2.5mm	32mm	180
C3152532-192VP	315mm	2.5mm	32mm	192VP
C3152532-200	315mm	2.5mm	32mm	200
C3152532-220	315mm	2.5mm	32mm	220
C3152532-250	315mm	2.5mm	32mm	250
C3152532-300	315mm	2.5mm	32mm	300
C3152540-192VP	315mm	2.5mm	40mm	192VP
C3252532-140	325mm	2.5mm	32mm	140
C3502532-140	350mm	2.5mm	32mm	140
C3502532-160	350mm	2.5mm	32mm	160
C3502532-180	350mm	2.5mm	32mm	180
C3502532-200	350mm	2.5mm	32mm	200
C3502532-212VP	350mm	2.5mm	32mm	212VP
C3502532-220	350mm	2.5mm	32mm	220
C3502532-240	350mm	2.5mm	2.5mm	240
C3502532-260	350mm	2.5mm	2.5mm	260
C3502532-300	350mm	2.5mm	32mm	300
C3502532-350	350mm	2.5mm	32mm	350
C3502540-180	350mm	2.5mm	40mm	180

HIGH SPEED STEEL - DM05 (continued)

Part No.	Diameter	Thickness	Bore	# Teeth
C3502540-220	350mm	2.5mm	40mm	220
C3502540-260	350mm	2.5mm	40mm	260
C3702532-220	370mm	2.5mm	32mm	220
C4003040-196VP	400mm	3.0mm	40mm	196VP

HIGH SPEED STEEL - DM05 BLANK BLADES

Blank blades which can be toothed to suit your requirements

Part No.	Diameter	Thickness	Bore	# Teeth
C2502032-000	250mm	2.0mm	32mm	BLANK
C2502040-000	250mm	2.0mm	40mm	BLANK
C2502532-000	250mm	2.5mm	32mm	BLANK
C2752032-000	275mm	2.0mm	32mm	BLANK
C2752040-000	275mm	2.0mm	40mm	BLANK
C2752532-000	275mm	2.5mm	32mm	BLANK
C2752540-000	275mm	2.5mm	40mm	BLANK
C3001632-000	300mm	1.6mm	32mm	BLANK
C3002532-000	300mm	2.5mm	32mm	BLANK
C3002538-000	300mm	2.5mm	38mm	BLANK
C3002540-000	300mm	2.5mm	40mm	BLANK
C3151632-000	315mm	1.6mm	32mm	BLANK
C3152532-000	315mm	2.5mm	32mm	BLANK
C3252540-000	325mm	2.5mm	40mm	BLANK
C3502532-000	350mm	2.5mm	32mm	BLANK
C3502540-000	350mm	2.5mm	40mm	BLANK
C3702532-000	370mm	2.5mm	32mm	BLANK
C4003040-000	400mm	3.0mm	40mm	BLANK

SAW BLADE HELPFUL TIP

BLADE BREAK IN

The extremely sharp tooth points and edges of new blades must be broken in before applying full feed pressure to the blade. A good analogy is that of writing with a freshly sharpened wooden pencil.

Recommended Procedure:

- Maintain regular blade speed to suit the material to be cut
- Reduce blade feed pressure or feed rate by 50% for the first 300 to 600 square centimeters of material cut
- Gradually increase feed pressure or feed rate after break in to full pressure rate.

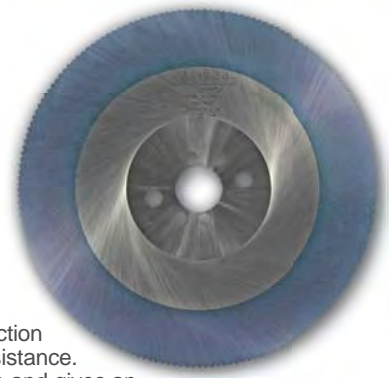

SPEEDFACE

Speedface is a PVD coating that reduces friction and increases wear resistance. This improves blade life and gives an excellent finish on the cut material. Speedface blades are suitable for cutting hard tempered steels, and more difficult to cut materials such as stainless steel.

Part No.	Diameter	Thickness	Bore	# Teeth
C2502032-SS000	250mm	2.0mm	32mm	BLANK
C2502032-SS180	250mm	2.0mm	32mm	180
C3152532-SS000	315mm	2.5mm	32mm	BLANK
C3152532-SS200	315mm	2.5mm	32mm	200
C3502532-SS000	350mm	2.5mm	32mm	BLANK
C3502532-SS240	350mm	2.5mm	32mm	240



COBALT

High speed steel with a 5% cobalt content, which increases the blade's hardness, compared to standard High Speed Steel DM05 material. Suitable for cutting hard materials that produce higher temperatures during the cutting process, such as some grades of stainless steel.

Part No.	Diameter	Thickness	Bore	# Teeth
C2502032CO-000	250mm	2.0mm	32mm	BLANK
C2502040CO-000	250mm	2.0mm	40mm	BLANK
C2502532CO-000	250mm	2.5mm	32mm	BLANK
C2752532CO-000	275mm	2.5mm	32mm	BLANK
C2752540CO-000	275mm	2.5mm	40mm	BLANK
C3002532CO-000	300mm	2.5mm	32mm	BLANK
C3152532CO-000	315mm	2.5mm	32mm	BLANK
C3152532CO-192VP	315mm	2.5mm	32mm	192VP
C3152532CO-200	315mm	2.5mm	32mm	200
C3502532CO-000	350mm	2.5mm	32mm	BLANK
C3502532CO-212VP	350mm	2.5mm	32mm	212VP

BANDSAW BLADES

M42 BI-METAL VARIABLE PITCH

For general purpose steel cutting



Packaged blades
available in popular sizes

Part No.	Length	Width	# Teeth
TO SUIT UE100S			
UE100BLADE-14	1470mm	13mm	14 TPI
TO SUIT UE120S			
UE120BLADE-14	1550mm	13mm	14 TPI
TO SUIT UE127DV			
UE127BLADE-14	1440mm	13mm	14 TPI
TO SUIT RF128 / RF128HDR			
RF128BLADE-14	1635	13mm	14 TPI
TO SUIT UE712A / RF812 / TM712N			
UE712BLADE-4/6	2360mm	19mm	4/6 TPI
UE712BLADE-5/8	2360mm	19mm	5/8 TPI
UE712BLADE-6/10	2360mm	19mm	6/10 TPI
UE712BLADE-8/12	2360mm	19mm	8/12 TPI
UE712BLADE-10/14	2360mm	19mm	10/14 TPI
TO SUIT WE200SV / WE210S / WP210SH			
WE210BLADE-4/6	2110mm	19mm	4/6 TPI
WE210BLADE-5/8	2110mm	19mm	5/8 TPI
WE210BLADE-6/10	2110mm	19mm	6/10 TPI
WE210BLADE-8/12	2110mm	19mm	8/12 TPI
WE210BLADE-10/14	2110mm	19mm	10/14 TPI
TO SUIT RF270S / RF270DR / RF270DRV			
RF270BLADE-4/6	2450mm	27mm	4/6 TPI
RF270BLADE-5/8	2450mm	27mm	5/8 TPI
RF270BLADE-6/10	2450mm	27mm	6/10 TPI
RF270BLADE-10/14	2450mm	27mm	10/14 TPI
TO SUIT WE260SH / WE270DS / WE275DSV / WP270SH / WP275DS			
WE260BLADE-4/6	2455mm	27mm	4/6 TPI
WE260BLADE-5/8	2455mm	27mm	5/8 TPI
WE260BLADE-6/10	2455mm	27mm	6/10 TPI
WE260BLADE-8/12	2455mm	27mm	8/12 TPI
WE260BLADE-10/14	2455mm	27mm	10/14 TPI
TO SUIT RF310S / WP310DS			
RF310BLADE-4/6	2725mm	27mm	4/6 TPI
RF310BLADE-5/8	2725mm	27mm	5/8 TPI
RF310BLADE-6/10	2725mm	27mm	6/10 TPI
RF310BLADE-8/12	2725mm	27mm	8/12 TPI
RF310BLADE-10/14	2725mm	27mm	10/14 TPI

Part No.	Length	Width	# Teeth
TO SUIT RF320HB			
RF320BLADE-4/6	2750mm	27mm	4/6 TPI
RF320BLADE-5/8	2750mm	27mm	5/8 TPI
RF320BLADE-6/10	2750mm	27mm	6/10 TPI
RF320BLADE-10/14	2750mm	27mm	10/14 TPI
TO SUIT WE350DS / WE350DSV / WE350DSA			
WE350BLADE-4/6	3160mm	27mm	4/6 TPI
WE350BLADE-5/8	3160mm	27mm	5/8 TPI
WE350BLADE-6/10	3160mm	27mm	6/10 TPI
WE350BLADE-8/12	3160mm	27mm	8/12 TPI
WE350BLADE-10/14	3160mm	27mm	10/14 TPI
TO SUIT MACC 300 / 301 / 320 / 315			
BLADE-27-2825-3/4	2825mm	27mm	3/4 TPI
BLADE-27-2825-5/8	2825mm	27mm	5/8 TPI
BLADE-27-2825-6/10	2825mm	27mm	6/10 TPI
BLADE-27-2825-8/12	2825mm	27mm	8/12 TPI
BLADE-27-2825-10/14	2825mm	27mm	10/14 TPI
TO SUIT MACC 330 / 380 / 400 / 410			
BLADE-27-3010-3/4	3010mm	27mm	3/4 TPI
BLADE-27-3010-4/6	3010mm	27mm	4/6 TPI
BLADE-27-3010-5/8	3010mm	27mm	5/8 TPI
BLADE-27-3010-6/10	3010mm	27mm	6/10 TPI
BLADE-27-3010-8/12	3010mm	27mm	8/12 TPI
BLADE-27-3010-10/14	3010mm	27mm	10/14 TPI
TO SUIT MACC 411			
BLADE-27-3200-3/4	3200mm	27mm	3/4 TPI
BLADE-27-3200-4/6	3200mm	27mm	4/6 TPI
BLADE-27-3200-5/8	3200mm	27mm	5/8 TPI
BLADE-27-3200-6/10	3200mm	27mm	6/10 TPI
BLADE-27-3200-8/12	3200mm	27mm	8/12 TPI
BLADE-27-3200-10/14	3200mm	27mm	10/14 TPI
TO SUIT MACC 420DI			
BLADE-34-4610-3/4	4610mm	34mm	3/4 TPI
BLADE-34-4610-4/6	4610mm	34mm	4/6 TPI
BLADE-34-4610-5/8	4610mm	34mm	5/8 TPI
TO SUIT MACC 650DI			
BLADE-34-5270-3/4	5270mm	34mm	3/4 TPI
BLADE-34-5270-4/6	5270mm	34mm	4/6 TPI
BLADE-34-5270-5/8	5270mm	34mm	5/8 TPI

Other blades sizes and teeth variations available on request



BANDSAW BLADE SELECTION GUIDE

Teeth Per Inch (TPI)	Wall Thickness ○	Solid Material ●
2/3 TPI	32 - 38mm	140 - 230mm
3/4 TPI	19 - 32mm	70 - 140mm
4/6 TPI	9 - 19mm	32 - 70mm
5/8 TPI	7 - 9mm	22 - 32mm
6/10 TPI	5 - 7mm	16 - 22mm
8/12 TPI	3 - 5mm	10 - 16mm
10/14 TPI	1 - 3mm	5 - 10mm

T.C.T. SAW BLADES

TUNGSTEN CARBIDE TIPPED SAW BLADES



Part No.	Diameter	Bore	# Teeth	Max. RPM
SSBL230-MS	230mm	25.4mm	48	2700
SSBL230-TS	230mm	25.4mm	80	2700
SSBL230-SS	230mm	25.4mm	80	2700
SSBL350-MS	355mm	25.4mm	66	1450
SSBL350-TS	355mm	25.4mm	90	1450
SSBL350-AL	355mm	25.4mm	100	1450

TUNGSTEN CARBIDE TIPPED SAW BLADES

With two pin holes - designed for use with MACC TA400 Saw

Part No.	Diameter	Bore	# Teeth
TCT4003632-96	400mm	32mm	96
TCT4003632-120	400mm	32mm	120

CUTTING FLUID

SEMI - SYNTHETIC METAL WORKING FLUID

Water mix cutting fluid designed for use with most coldsaws, bandsaws, & metal working machinery that use a recirculating coolant system with fluid storage tank.

- Resistant to bacterial & fungal growth, extending fluid service life
- Provides an excellent surface finish & extends blade life
- Contains corrosion inhibitors to protect machine parts and workpiece



Mix 1 part fluid to 8 parts water

Part No.	Description
MF-5LITRE	5 Litre Macc Synthetic Metal Working Fluid
MF-20LITRE	20 Litre Macc Synthetic Metal Working Fluid

ALUMINIUM METAL WORKING FLUID

Water mix cutting fluid designed for use with high speed T.C.T blade metal cutting saws. Provides excellent surface finish & extends blade life.



Mix 1 part fluid to 8 parts water.

Part No.	Description
MF-ALUM5L	5 Litre Macc Aluminium Metal Working Fluid

GROZ COOLANT MIXER



Features

- For mixing liquid coolant concentrate with water
- Lightweight aluminium body
- Driven by pressure from water supply
- Includes full flow brass ball valve & also fitted with 2 back flow preventers
- Adjustment of mixing ratio is variable & controlled through a simple turn of the knob
- Inbuilt suction tube & 2" bung that fits directly onto 55 gal (205 litre) coolant drums
- Wetted Components include aluminium, stainless steel, brass, acetal, PVC, nitrile rubber

Part No.	Code	Application	Mixing Ratio	Capacity
GZ-61102	CMX/3	Metal Working Fluids	0 to 9 %	1100 Litre per hour (290 Gallons per hr)

Magnetic Base Drilling Machines

Cutting Tools

Clamps

Engineer's Tools

Sharpening Machines

Metal Cutting Saws

Drilling Machines

Bevelling Machines & Welding Carriages

Punches & Shears

Grinding Machines

Fans & Ventilators

Workshop Storage

M7 Airtools

NPK Airtools

Pneumatic Products



DRILLING MACHINES

Drillmate	177
Vacforce 2000	177
Drilling Machines - Belt Drive	178
Drilling Machines - Geared Head	180

DRILLMATE PORTABLE DRILL PRESS

Features

The Drillmate portable drill press is a unique design for use with electric & pneumatic drills, that attaches to the workpiece & assists in ensuring even pressure is correctly applied to the cutting edge of the drill or annular cutter.

- Ergonomical** - Easier drilling of materials with comfortable stance
- Safety** - Safer drilling of materials - both hands used
- Productivity** - Faster and more economical production of holes

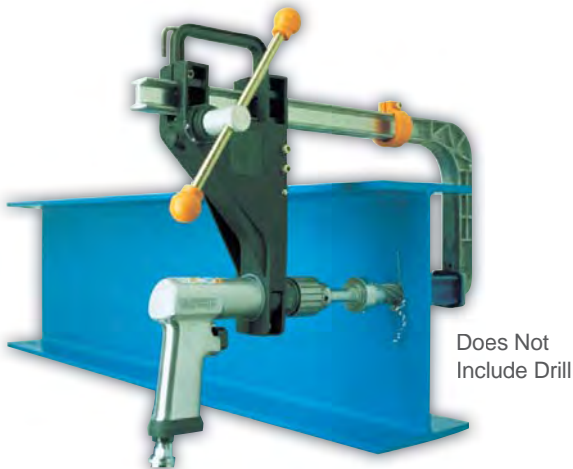

DRILLMATE FOR USE WITH ELECTRIC DRILLS

- 43mm collar
- Includes pipe attachment & H Beam attachment

Part No.	Description
DM100	Drillmate For Use With Electric Drills

DRILLMATE FOR USE WITH PNEUMATIC DRILLS

- 46mm collar
- Includes 4 piece shim kit; 0.5mm, 0.75mm, 1.0mm, 1.5mm
- Includes pipe attachment & H beam attachment

Part No.	Description
DM100A	Drillmate For Use With Pneumatic Drills

VACFORCE 2000 VACUUM BASE DRILL PRESS

Features

The Vacforce 2000 consists of a vacuum base to clamp to the surface of the material and an air feed cylinder to push the cutting tool through the cut with less effort by the operator. It also incorporates a safety valve which prevents operation unless the unit is locked to the surface.

Due to the design, the surface to which the unit will adhere does not have to be smooth & flat. Surface imperfections are tolerated.

Capacity

63mm diameter x 5mm depth
26mm diameter x 20mm depth

Dimensions

Length : 280mm
Width : 89mm
Height : 280mm
Weight : 2.7kg

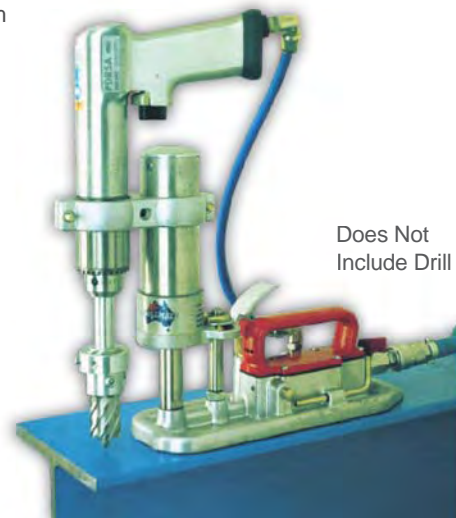

Part No.	Description
DMVAC2000	Vacforce 2000 Vacuum Base Drill Press

DRILLING MACHINES

BELT DRIVE



BENCH DRILL PRESS

Part #	TD0813	TD1013	TD1316	TD1416
Drilling Capacity (mm)	13mm (1/2")	13mm (1/2")	16mm (5/8")	16mm (5/8")
Spindle Taper	-	-	#2MT	#2MT
Chuck	1.5-13mm B16	1.5-13mm B16	3-16mm B16	3-16mm B16
Motor Power	250W 240V	375W 240V	375W 240V	450W 240V
Spindle Travel (mm)	50	65	85	85
Speed	5 Speed 620-2620	5 Speed 620-2620	16 Speed 180-2770	16 Speed 180-2770
Swing (mm)	210	260	325	360
Table Size / Base Size (mm)	160x160 / 290x190	200x200 / 340x210	290 / 420x250	290x290 / 460x272
Column Diameter (mm)	46	58	72	72
Height (mm)	580	680	980	1000
N.W. / G.W. (kg)	19 / 20	27 / 29	50 / 52	60 / 63

Features

- Quality casting, construction & componentry
- Emergency stop
- NVR safety switch

Each Unit Supplied With :

- Chuck safety guard
- Drill chuck & arbor
- Drill drift (on MT models)



PEDESTAL DRILL PRESS

Part #	TD1316F	TD1416F	TD1420F	TD1825F	TD2032F
Drilling Capacity (mm)	16mm (5/8")	16mm (5/8")	20mm (3/4")	25mm (1")	32mm (1-1/4")
Spindle Taper	#2MT	#2MT	#3MT	#3MT	#4MT
Chuck	3-16mm B16	3-16mm B16	5-20mm B22	5-20mm B22	5-20mm B22
Motor Power	550W 240V	550W 240V	750W 240V	1500W 240V	1500W 240V
Spindle Travel (mm)	85	85	85	120	120
Speed	16 Speed 180-2770	16 Speed 180-2770	12 Speed 280-2380	12 Speed 150-2450	12 Speed 150-2450
Swing (mm)	325	360	360	450	510
Table Size / Base Size (mm)	290 / 460x272	290 x 290 / 460x272	290x290 / 460x272	350x350 / 500x375	420x480 / 560x450
Column Diameter (mm)	72	72	80	92	92
Height (mm)	1580	1600	1600	1710	1710
N.W./G.W. (kg)	60 / 63	70 / 74	80 / 84	120 / 128	145 / 153

EXTRA HEAVY DUTY INDUSTRIAL DRILLING MACHINE RANGE

Each unit supplied with :

- Drill chuck & arbor
- Drill drift



BENCH DRILL PRESS

Part #	K1418	K1720HD
Drilling Capacity (mm)	23mm (7/8")	23mm (7/8")
Spindle Taper	#2MT	#2MT
Chuck	16mm #3JT	16mm #3JT
Motor Power	550W 240V	750W 240V
Spindle Travel (mm)	85	85
Speed	16 Spd 180-2700	12 Spd 290-2330
Swing (mm)	365	430
Table Size / Base Size (mm)	ø350 / 458x265	ø350 / 505x278
Column Diameter (mm)	80	80
Height (mm)	1010	1010
Weight (kg)	60	72



PEDESTAL DRILL PRESS

Part #	K1418F	K1720HFD
Drilling Capacity (mm)	23mm (7/8")	23mm (7/8")
Spindle Taper	#2MT	#2MT
Chuck	16mm #3JT	16mm #3JT
Motor Power	550W 240V	750W 240V
Spindle Travel (mm)	85	85
Speed	16 Spd 180-2700	12 Spd 290-2330
Swing (mm)	365	430
Table Size / Base Size (mm)	350 / 458x265	350 / 495x280
Column Diameter (mm)	80	80
Height (mm)	1600	1600
Weight (kg)	70	78

QUALITY TAIWANESE MACHINES WITH HEAVY DUTY CASTING AND CONSTRUCTION FOR PROVEN LASTING DURABILITY IN INDUSTRIAL WORKSHOPS



MAXI-DRILL PRESS

Part #	K2532-1	K2532-3
Max Drilling Capacity (mm)	32mm (1-1/4")	
	#3MT	
Chuck	16mm #3JT	
Motor Power	1200W 240V	1500W 415V
Spindle Travel (mm)	122	
Speed	12 Speed 145-2530	
Swing (mm)	560	
Table Size / Base Size (mm)	473x410 / 575x500	
Column Diameter (mm)	92	
Height(mm)	1752	
Weight (kg)	158	

FOR CHUCKS, ARBORS, REDUCTION SLEEVES & DRILL DRIFT KEYS SEE PAGES 111 & 112



Magnetic Base Drilling Machines

Cutting Tools

Clamps

Engineer's Tools

Sharpening Machines

Metal Cutting Saws

Drilling Machines

Bevelling Machines & Welding Carriages

Punches & Shears

Grinding Machines

Fans & Ventilators

Workshop Storage

M7 Airtools

NPK Airtools

Pneumatic Products

DRILLING MACHINES

GEARED HEAD

GEARED HEAD DRILLING MACHINE

- Quality precision machine for drilling & tapping
- No. 4 Morse taper spindle
- 1120W motor, single or three phase available
- Micro feed precision
- Geared head tilts 90° right & left
- Forward and reverse operation
- Accessories include arbor, 16mm drill chuck, drill sleeves



GEARED HEAD DRILLING & MILLING MACHINE

- Quality precision machine for drilling, milling & tapping
- No. 4 Morse taper spindle
- 1120W motor, single or three phase available
- Micro feed precision
- Geared head tilts 90° right & left
- Forward and reverse operation
- Recirculating coolant system
- Accessories include arbor, draw bar, milling chuck, 16mm drill chuck, drill sleeves



GEARED HEAD DRILLING & MILLING MACHINE AUTOMATIC VERSION

- Automatic down feed



Part #	TGD400-1 TGD400-3
Max Drilling Capacity	40mm
Spindle Taper	4MT
Spindle Nose To Base	1180mm
Spindle Nose To Table	715mm
Spindle To Column	272.5mm
Diameter Of Column	115mm
Spindle Travel	120mm
Swing	660mm
Spindle Speeds (rpm)	75, 170, 280, 540, 960, 1600
Table Dimensions	540 x 470mm
Overall Height	1770mm
Base Dimensions	650 x 450mm
N.W. / G.W.	320 / 370kg
Shipping Dimensions	740 x 720 x 1830mm

Part #	TGMD400-1 TGMD400-3 TGMD400A-3
Max Drilling Capacity	40mm
Spindle Taper	MT4
Spindle Nose To Base	1180mm
Spindle Nose To Table	610mm
Spindle To Column	272.5mm
Diameter Of Column	115mm
Quill Travel	120mm
Swing	660mm
Spindle Speeds (rpm)	75, 170, 280, 540, 960, 1600
Table Surface	600 x 190mm
Cross Travel	190mm
Longitude Travel	370mm
Overall Height	1770mm
Base Dimensions	650 x 450mm
N.W. / G.W.	340 / 390kg
Shipping Dimensions	820 x 720 x 1830mm

COOLANT SYSTEMS

For use with most metal drilling and cutting applications.



Part No.	Description
KCE17L-1	240V 1PH Coolant System
KCE17L-3	415V 3PH Coolant System

REMOTE FOOT SWITCH

IP54 rated



Part No.	Description
FS502	Foot Switch, Suitable For 240V, M20 Cable Entry

GEARED HEAD DRILLING MACHINE

- Quality Taiwanese precision machine for drilling & tapping
- No. 3 Morse taper spindle
- 1120W motor single or three phase
- Geared head tilts 90° right & left
- Forward and reverse operation
- Accessories include arbor, draw bar
- No chuck supplied



Part #	GEM400GD-1 GEM400GD-3	GEM400GS-1 GEM400GS-3
Description	Bench Drill	Pedestal Drill
Max Drilling Capacity	40mm Cast Iron 32mm Steel	
Spindle Taper	#3 Morse Taper	
Spindle Nose To Base	620mm	1100mm
Spindle Nose To Table	-	700mm
Spindle To Column	275mm	
Diameter Of Column	110mm	115mm
Quill Diameter	75mm	
Quill Travel	120mm	
Swing	550mm	
Head Tilting	90° Right & Left	
Head Swivel	360°	
Spindle Speeds (240V)	100, 220, 380, 760, 1240, 2500rpm	
Spindle Speeds (415V)	50, 100, 190, 380, 670, 1250rpm	
Table Surface	-	410 x 450mm
Overall Height	1075mm	1860mm
Base Dimensions	450 x 650mm	
N.W. / G.W.	220 / 245kg	290 / 305kg
Shipping Dimensions	800 x 780 x 1120mm	730 x 550 x 1950mm

GEARED HEAD DRILLING & MILLING MACHINE

- Quality Taiwanese precision machine for drilling & tapping
- No. 3 Morse taper spindle
- 1120W motor single or three phase
- Geared head tilts 90° right & left
- Forward and reverse operation
- Accessories include arbor, draw bar
- No chuck supplied



Part #	GEM400G-1 GEM400G-3	GEM400GCT-1 GEM400GCT-3
Description	Bench Mill / Drill	Pedestal Mill / Drill
Max Drilling Capacity	40mm Cast Iron 32mm Steel	
Spindle Taper	#3 Morse Taper	
Spindle Nose To Base	650mm	1100mm
Spindle Nose To Table	480mm	580mm
Spindle To Column	275mm	
Diameter Of Column	110mm	115mm
Quill Diameter	75mm	
Quill Travel	120mm	
Swing	550mm	
Head Tilting	90° Right & Left	
Head Swivel	360°	
Spindle Speeds (rpm)	100, 220, 380, 760, 1240, 2500rpm	
Spindle Speeds (rpm)	50, 100, 190, 380, 670, 1250rpm	
Table Surface	730 x 210mm	585 x 190mm
Cross Travel	285mm	210mm
Longitude Travel	410mm	340mm
Overall Height	1090mm	1880mm
Base Dimensions	450 x 650mm	
N.W. / G.W.	310 / 340kg	325 / 360kg
Shipping Dimensions	800 x 780 x 1120mm	730 x 550 x 1950mm

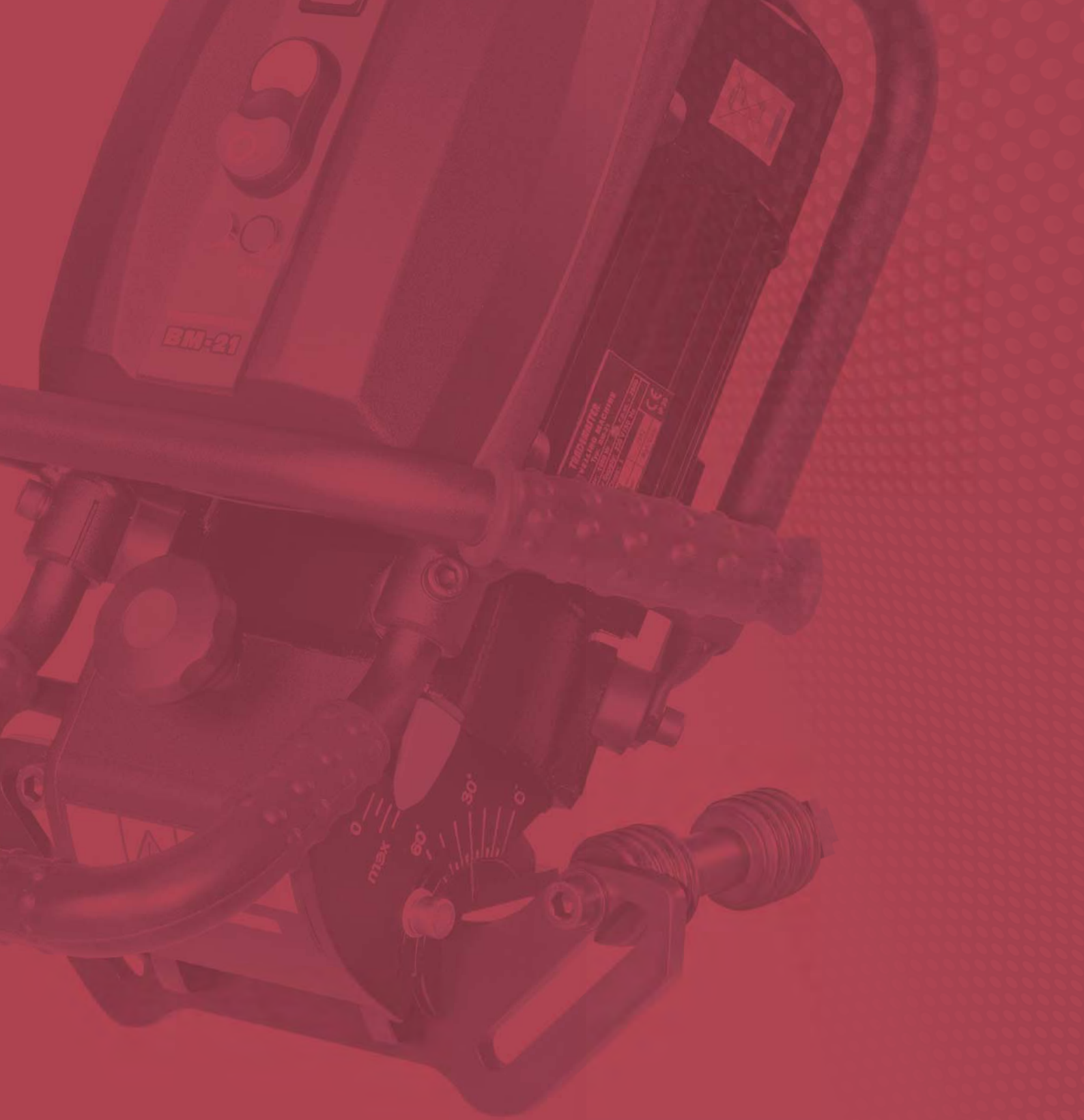

WELDING CARRIAGES & BEVELLING MACHINES

Welding Carriages	184
Plate Beveling Machines	188
Pipe Beveling Machines	193

- ▶ **BEVELLING MACHINES**
- ▶ **WELDING CARRIAGES**

**HIGH PRECISION & EXTRA HEAVY DUTY
EUROPEAN MANUFACTURED MACHINERY**



PLATE BEVELLING MACHINES

BM20 PORTABLE BEVELLER

Overview

The BM20 is a quality European made, portable, easy to use, heavy duty machine designed for bevelling steel plates & pipes prior to welding or edge finishing work. The bevelling machine is fitted with two milling heads each holding six high tech inserts allowing smooth operation and exceptional efficiency.

Milling cutter heads provide a smooth milled finish. End planing can be achieved with optional attachment.



Part No.	WA-BM20
Induction Motor	1100W
Grinding Angle	15° - 60°
Speed	2820rpm
Weight	19.5kg

Maximum Bevel Width

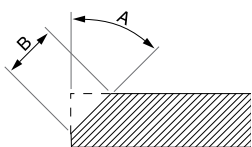

A	15° - 60°
B	0 - 18mm

Optional Accessories & Consumables

Part No.	Description
WAP-B20/4030	Replacement Standard Cutting Tips (12 Required)
WAP-B20/4210	0° Edge Planing Attachment To Suit BM20 & BM20+
WAP-B20/4010	Pipe Attachment To Suit BM20 & BM20+ 150 - 300mm Pipe
WAP-B20/4020	Pipe Attachment To Suit BM20 & BM20+ 258 - 600mm Pipe



Plate bevelling



0° Edge planing attachment (option)



Pipe bevelling 150 - 300mm (option)



Pipe bevelling 260 - 600mm (option)

BM20 PLUS PORTABLE BEVELLER

Overview

The BM20 PLUS is a quality European made, portable, easy to use, heavy duty machine designed for bevelling steel plates & pipes prior to welding or edge finishing work. The bevelling machine is fitted with two milling heads each holding five carbide inserts allowing smooth operation and exceptional efficiency.

Milling cutter heads provide a smooth milled finish. End planing can be achieved with optional attachment.

Features

- Newly designed milling head arrangement which is fast and easy to set up

Part No.	WA-BM20+
Induction Motor	1600W
Grinding Angle	15° - 60°
Speed	3340rpm
Weight	20.5kg

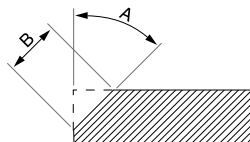
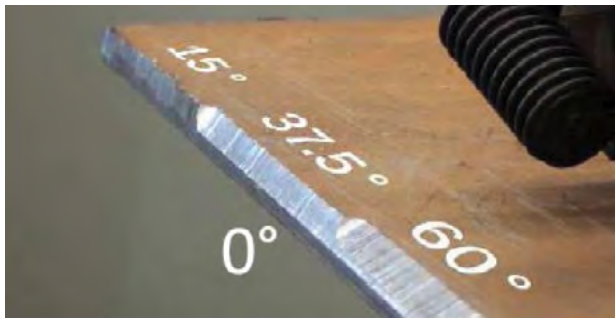

Maximum Bevel Width

A	15°	30°	45°	60°
B	21mm	20.5mm	21mm	20.5mm



Optional Accessories & Consumables

Part No.	Description
WAP-B020	Replacement Standard Cutting Tips (10 Required)
WAP-B20/4210	0° Edge Planing Attachment To Suit BM20 & BM20+
WAP-B20/4010	Pipe Attachment To Suit BM20 & BM20+ 150-300mm Pipe
WAP-B20/4020	Pipe Attachment To Suit BM20 & BM20+ 258-600mm Pipe
WAP-B20/4230	Round Plate Beveling Attachment To Suit BM20+



Plate bevelling



0° Edge planing attachment (option)



Pipe bevelling 260 - 600mm (option)

BM21

BM21S FOR USE WITH STAINLESS STEEL PORTABLE BEVELLERS

Overview

The BM21 is the latest generation portable beveling machine, for machining plates and pipes prior to welding. This new and improved design offers a number of innovative solutions that increase ergonomics and ensure even more comfort and work safety of the operator. Also available is the BM21S Beveling Machine, specifically designed for working with stainless steel.

Features

- New single milling head equipped with 10 indexable inserts that require no set up and makes the machining process far more efficient with little operator's effort
- Extended working range from 0° to 60° with continuous angle adjustment
- Easy setting of chamfer angle and bevel width
- One universal guideline for beveling both plates and pipes
- Bevels pipes 150 - 300mm diameter, optional attachment available for beveling pipes 260 - 600mm diameter
- 4 vibration isolators protect both the operator and electronics of the machine against harmful vibration
- Unique BM21S features include a low speed (grey colour) motor, plus guide plate and guide rollers made of stainless steel

Specifications

Part No.	WA-BM21	WA-BM21S
Induction Motor	1600W	1600W
Grinding Angle	0° - 60°	0° - 60°
Speed	2800rpm	1360rpm
Weight	21kg	21kg

Maximum Bevel Width

	0°	15°	30°	45°	60°
A					
B	21mm	18.5mm	18.5mm	21mm	18.5mm

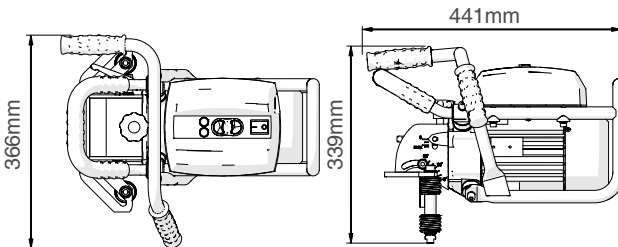
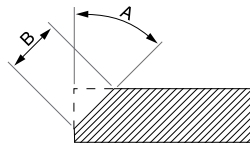

Optional Accessories & Consumables

Part No.	Description
WAP-B020	Replacement Standard Cutting Tips (10 Required)
WAP-BM21/3010	Large Pipe Attachment For 258 - 600mm Pipe



BM21



BM21S



Plate beveling



Pipe beveling



Plate facing-off

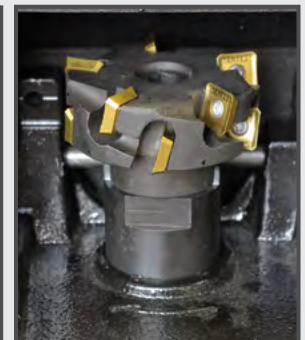

Mono block milling head

ABM-14 PLATE & PIPE BEVELLER

Overview

The Trademaster ABM-14 is a beveling machine designed to mill plates and pipes made of carbon steel, alloy steel, stainless steel or aluminum alloys.

In just one single run the machine can bevel up to 2.6 m/min. (8.5 ft/min.) to a width of 12 mm (1/2") in workpieces with tensile strength of $R_m \leq 392$ MPa (57,000 psi).

Maximum bevel width is 14 mm (9/16"). Depending on materials two or more runs are needed.

Bevel angles incl. 30° (standard) and with optional angle variation devices also 22.5°, 25°, 35°, 37.5° or 45°.

The machine can bevel plates from the top and bottom.

In the case of the milling tool getting stuck in the material and beveling cannot be continued the direction of rotation of the tool can be reversed to release the machine from the workpiece.

Hearing protection equipment not required as the noise produced by the machine does not exceed 70 dB.

Features

- Fast and efficient
- Bevels both small and large pieces to cover most of the common applications for its type
- Auto feed on large plates with optional trolley
- Beveling of lower edge in inverted position
- Standard shearing cutter for machining carbon steel
- 2 optional shearing cutters dedicated to stainless/alloyed steel and aluminum
- Reversible spindle against stuck milling tool
- Versatile and transportable on its own trolley
- Low noise



Standard Part No.	WA-ABM14
Voltage	3~ 400 V + PE, 50/60 Hz
Power	2200 W
Spindle speed	9 rpm
Bevel angle range (β – depending on angle device in use)	30° 22.5°, 25°, 35°, 37.5°, 45° (options)
Bevel width (b)	up to 14 mm (9/16")
Maximum bevel in one single run	12 mm (in 40 Kg/ 392 MPa carbon steel)
Minimum plate thickness	6 mm (1/4")
Maximum plate thickness	40 mm (1-9/16")
Minimum plate width	55 mm (2-3/16")
Bevel length per minute	2.6 m (8.5 ft)
Minimum pipe ID	100 mm (4")
Weight	65 kg

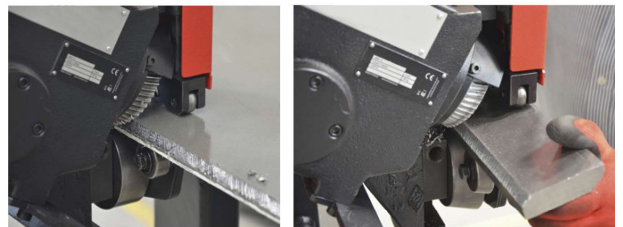
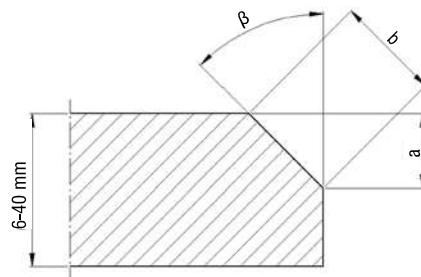

Bevel width up to 14mm	Bevel angles 30°, (option): 22.5°, 25°, 35°, 37.5°, 45°	Min plate thickness 6mm Max plate thickness 40mm	Min plate width 55mm	Top beveling	Bottom beveling	Pipe OD beveling Min. ID 100mm

SINGLE RUN BEVELLING - CARBON STEEL

Rm	≤ 392 MPa (57,000 psi)		392-490 MPa (57,000-71,000 psi)		490-588 MPa (71,000-85,000 psi)	
β	b [mm]	a [mm]	b [mm]	a [mm]	b [mm]	a [mm]
22.5°	12	11	10	9	8	7.5
30°	12	10	10	8.5	8	7
35°	12	9.5	10	8	8	6.5
37.5°	12	9	10	7.5	8	6
45°	12	8.5	10	7	8	5.5

SINGLE RUN BEVELLING - STAINLESS / ALLOY STEEL

Rm	≤ 490 MPa (71,000 psi)		490-588 MPa (71,000-85,000 psi)		588-686 MPa (85,000-100,000 psi)	
β	b [mm]	a [mm]	b [mm]	a [mm]	b [mm]	a [mm]
22.5°	6	5.5	5	4.5	4.2	3.8
30°	6	5	5	4.3	4.2	3.6
35°	6	5	5	4	4.2	3.5
37.5°	6	4.5	5	4	4.2	3.3
45°	6	4	5	3.5	4.2	3

Set Includes :

- WA-ABM14 beveller
- Milling cutter for stainless steel
- Cutter extraction tool
- Tube beveling shaft
- Tube beveling washer
- Flat wrenches: 12-13mm, 18-19mm, 24-26mm
- Hex wrenches: 5mm and 6mm
- Operator's manual

Optional and Spare Accessories :

- FRZ-000586 Milling cutter for mild steel
- FRZ-000588 Milling cutter for stainless steel
- FRZ-000587 Milling cutter for aluminum



- SCG-000002 Milling cutter extraction tool



- PRW-000100 Angle Variation Device 22.5°
- PRW-000101 Angle Variation Device 25°
- PRW-000105 Angle Variation Device 30°
- PRW-000102 Angle Variation Device 35°
- PRW-000103 Angle Variation Device 37.5°
- PRW-000104 Angle Variation Device 45°

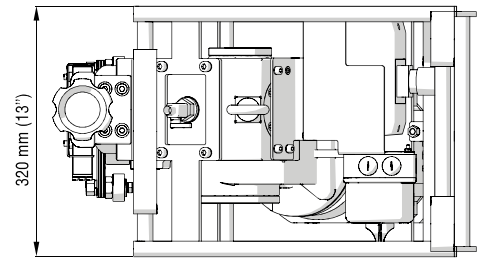
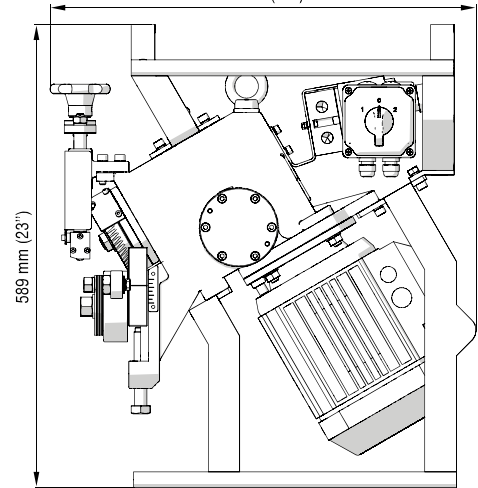

- WOZ-000009 Adjustable trolley
- TRZ-000017 Tube beveling shaft
- PDK-000240 Tube beveling washer



Magnetic
Base
Drilling
Machines

Cutting
Tools

Clamps

Engineer's
Tools

Sharpening
Machines

Metal
Cutting
Saws

Drilling
Machines

Beveling
Machines
& Welding
Carriages

Punches
& Shears

Grinding
Machines

Fans &
Ventilators

Workshop
Storage

M7
Airtools

NPK
Airtools

Pneumatic
Products

ABM-50 PLATE & PIPE BEVELLER

Overview

ABM-50 produces accurate high-quality double-sided bevels without thermal distortion or creation of heat affected zone on plate thickness range 8 - 80mm using a purpose designed milling head with eight 4-sided indexable cutting inserts. Continuously adjustable bevel angle between 15 and 60 degrees (for both top and bottom bevelling) requires no tooling to change.

Features

- Auto-feed portable beveller
- Real-time measurement and on-screen display of exact bevel geometry and cutting parameters
- Bevel width up to 50mm at 45 degrees
- 180° inversion allows for creation of a double-sided bevel – no need to rotate or flip heavy material reduces material handling costs and improves shop safety
- Variable spindle speed for work on a variety of steel grades and thicknesses
- Versatile and transportable on its own trolley
- Equipped with milling head including 8 replaceable inserts
- Feedback-controlled overload system

Remote Control Panel

ABM-50 features an unique remote control panel with LCD display that shows exact bevel geometry as well as enables precise adjustment of spindle speed and feed speed to optimize them depending on material grade incl. stainless steel, aluminum etc.

The operator can easily adjust and monitor the following parameters:

- Bevel angle
- Bevel width
- Bevel height
- Depth of cut
- Spindle speed
- Feed rate
- Spindle load

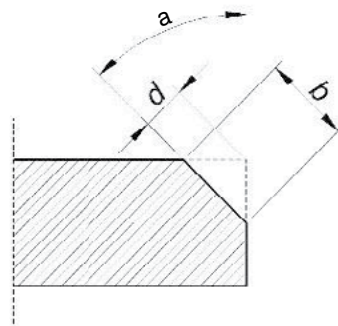
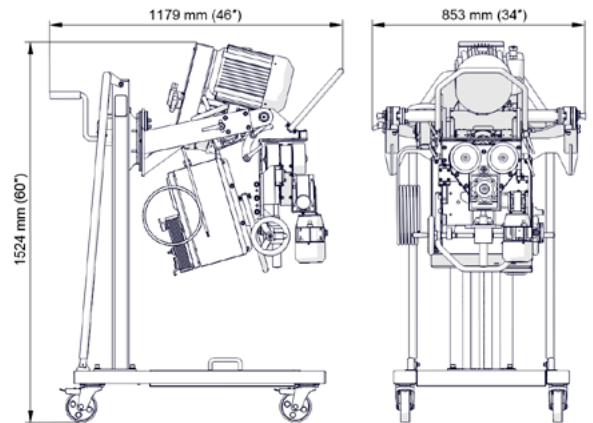

a	b
15°	66mm
30°	52mm
45°	50mm
60°	51mm

Part No.	ABM-50
Voltage	3~400 V+ PE, 50/60 Hz 3~480 V+ PE, 50/60 Hz
Power	6.5kw
Spindle speed (no load)	300 - 800rpm
Feed speed	0 - 1.2m/min
Bevel angle	15 - 60°
Maximum bevel width	50mm
Maximum depth of cut allowed per single pass	6mm
Plate thickness	8 - 80mm
Required ambient temperature	0 - 40°C
Weight	320kg

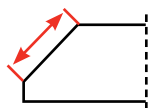

Bevel width
up to 50mm (45°)
up to 66mm (15°)



Bevel angles
top 15° - 60°
bottom 15° - 60°

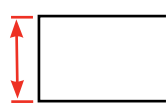

Min plate thickness 8mm
Max plate thickness 80mm

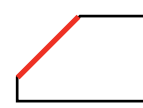

Top bevelling

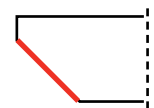

Bottom bevelling

RAIL TUG WELDING AND CUTTING CARRIAGE

Overview

The Rail Tug is a digitally controlled travel tractor designed for the mechanization of welding and thermal cutting processes. The Rail Tug can be used with semi-flexible track for plate and tank work with a minimum radius of 5m (16 ft) or adapted to bent ring rail for pipe and tube applications. Using a vacuum system allows the track to be clamped to non-ferrous surfaces (stainless steel, aluminium etc.) The Rail Tug economically meets a broad array of welding and cutting applications on flat or curved plate, tube and pipe.

Features

- Compact, lightweight design
- Closed-loop position control system based on electric motor with encoder - ensures increased accuracy of speed and position
- Rack and pinion drive
- Consistent heat input reduces distortion
- Reduces wasted filler metal - eliminates over welding
- Digital LED display for presetting of travel speed
- Automatic arc on/off initiates welding and travel simultaneously
- Oxy-fuel and plasma cutting possible with optional accessories
- Suitable for variety of circumferential and irregular surface applications down to minimum radius of 10mm (4")
 - Ring tracks on diameters from 200mm (8") OD up to 3m (10ft) OD
 - Custom rolled tracks on diameters from 3m (10ft) OD up to 10m (32ft) OD
 - Semi-flexible tracks can be flexed to minimum radius of 5m (16ft) without permanent deformation
- Quick-clamping torch holder mechanism for different types of torches with diameters of 16-22mm (0.63-0.87"); up to 35mm (1.38") option
- Precise torch adjustment with screw drive cross slide
- Convenient external 230V, 115V power supply
- Improves working environment - removes operator from heat and fumes
- High speed up to 3m/min makes plasma cutting available

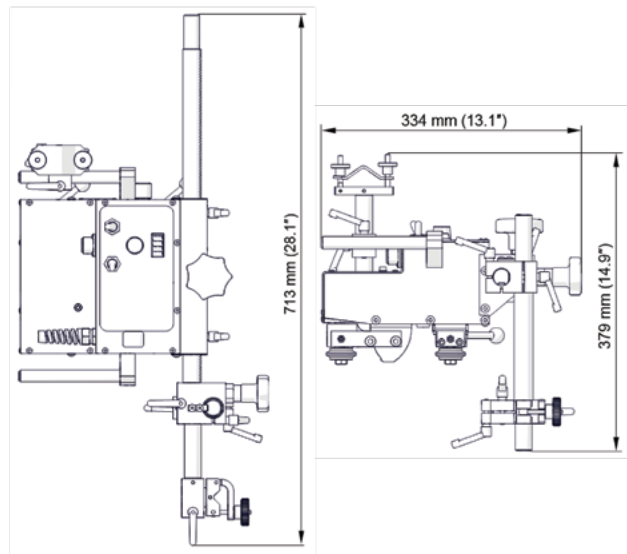

Part No.	RAIL TUG	
Voltage	1~115-230 V, 50/60 Hz	
Power	66w	
Welding position	PA / 1F / 1G	
	PB / 2F	
	PC / 2G	
	PD / 4F	
	PE / 4G	
	PG / 3F (Please contact your dealer)	
Fixing on pipes and around work pieces	Ring tracks	from 200mm OD up to 3m OD
	Custom rolled tracks	from 3m OD up to 10m OD
	Semi-flexible track	Minimum curvature radius of 5m
Torch type	MIG/MAG, SAW, Plasma, Oxy-fuel	
Torch diameter	MIG/MAG	16-22mm up to 35mm (option)
	SAW, Plasma	
	Oxy-fuel	
Horizontal pulling force	300N	
Vertical pulling force	200N	
Horizontal speed	10-200cm/min	
Vertical speed	10-200cm/min	
Weight	10kg	



- Magnetic Base Drilling Machines
- Cutting Tools
- Clamps
- Engineer's Tools
- Sharpening Machines
- Metal Cutting Saws
- Drilling Machines
- Bevelling Machines & Welding Carriages
- Punches & Shears
- Grinding Machines
- Fans & Ventilators
- Workshop Storage
- M7 Airtools
- NPK Airtools
- Pneumatic Products

Track Systems

Trademaster offers lightweight and portable track system for a variety of circumferential and straight line applications. The rigid and semi-flexible tracks are joinable for unlimited run length and can be mounted to work surface with several types of magnetic units or vacuum units for non-ferrous applications to allow travel in any plane or position. Choose the appropriate track system and auxiliary accessories for your own application.

Ring Tracks

For circumferential applications from 200mm OD up to 3000mm OD.

Ring Track Supports

Ring tracks can be equipped with various supports depending on the customer's needs.



WAP-RB2210 WAP-RB2208 Support with plastic feet

Part No.	Description
WAP-RB2210	Support with bolts
WAP-RB2208	Support with magnets
-	Support with plastic feet



Custom Rolled Tracks

Custom rolled tracks are available for circumferential applications from 3m OD up to 10m OD



Rigid Tracks

For straight line applications

Rigid track length 2m
WAP-RB2025

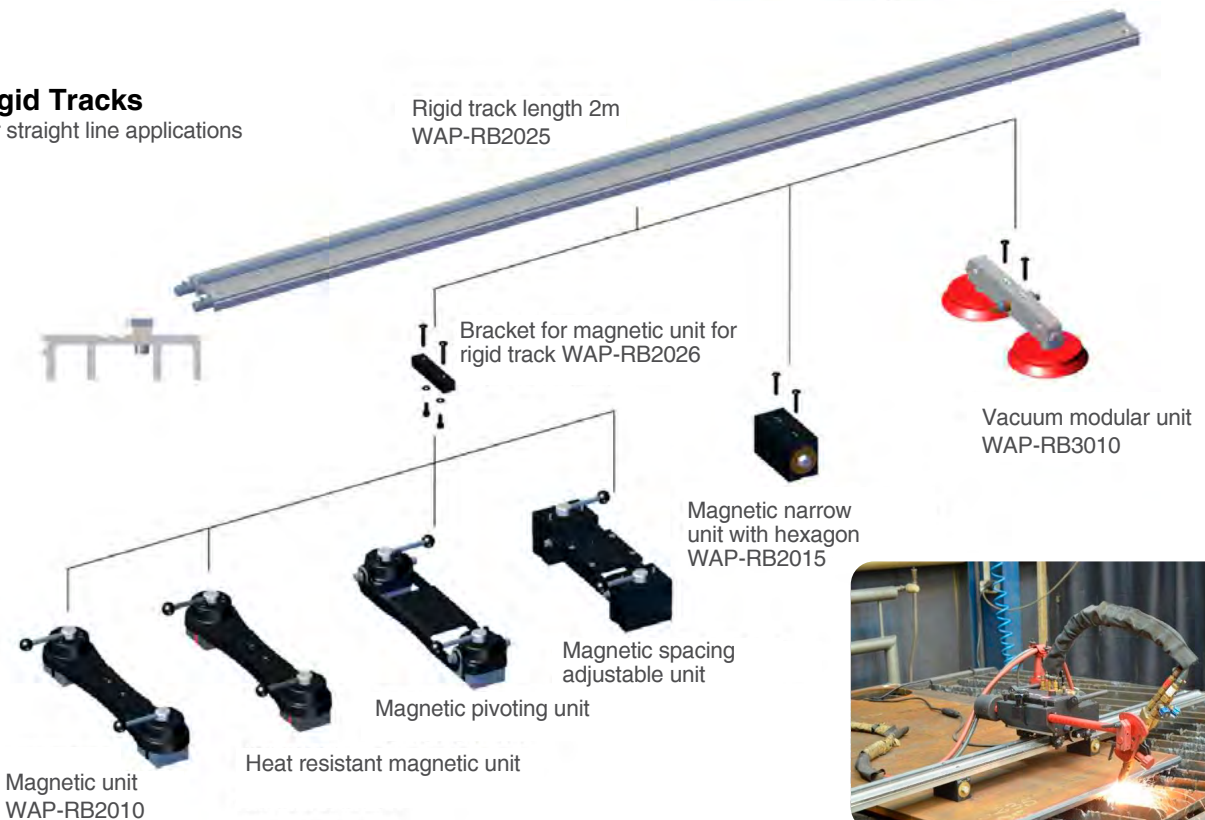

Magnetic unit
WAP-RB2010

Heat resistant magnetic unit

Magnetic pivoting unit

Magnetic spacing adjustable unit

Magnetic narrow unit with hexagon
WAP-RB2015

Vacuum modular unit
WAP-RB3010



ABM28 AUTO-FEED PORTABLE BEVELLING MACHINE

Overview

The ABM28 is an automatic track feed beveling machine designed for milling edges of plates up to 35mm thick with the standard equipment supplied, and up to 70mm with optional accessories. The intelligent design provides a very fast and effortless setup, and delivers perfect results with minimal operator effort or skill. The automatic feed and controlled travel speed helps to increase productivity and eliminate operator error.

With the variable travel speed control, the ABM28 can mill all types of metal including stainless steel, aluminium and composites. It can also mill plates in both directions eliminating unnecessary "empty journeys". The ABM28 is equipped with an overload control system to protect the machine, the tooling and the operator. The length of the guide track can be extended to any required length.

The beveling angle can be set between -60° and 60°, including facing at 0°. This allows both the top and underside of the plate to be bevelled without moving the material. Using optional accessories, the ABM28 can also create J-groove bevels.

Specifications

Part No.	WA-ABM28
Plate Thickness	10mm Minimum To 35mm Maximum, 70mm With Optional Attachment
Machining Angle	-60° to 60°
Motor	1600 Watt 240V 2800rpm
Dimensions	1211 W x 532 H x 619 D

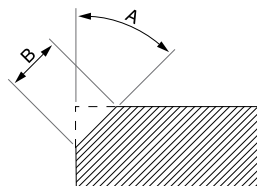

Maximum Bevel Width

	0°	30°	45°	60°
A				
B	35mm	30mm	28mm	30mm

Optional Accessories & Consumables

Part No.	Description
WAP-B020	Replacement Standard Cutting Tips (10 Required)
WAP-B28/6130	Track Clamp For Plate Up To 35mm Thick
WAP-B28/6140	Track Clamp For Plate Up To 70mm Thick
WAP-B28/6150	Positioner Unit For Plate Up To 35mm Thick
WAP-B28/6160	Positioner Unit For Plate Up To 70mm Thick
WAP-B28/6170	Rail Segment 1200mm Long
WAP-B28/6180	Milling Unit Support For Beveling 35 - 70mm 0° To 60°
WAP-B28/6190	Milling Unit Support For Beveling 35 - 70mm 0° To -60°



Plate facing-off



-60° Plate beveling



J-groove beveling

Package Includes

- Beveling Machine
- 1200mm Track Segment x 2
- Positioner Unit, 35mm
- 35mm Track Clamp x 3
- Standard Milling Unit Support

PRO 5 PB PORTABLE PIPE BEVELLER

Overview

The Trademaster PRO 5 PB is a European made I.D. mounted pipe bevelling machine, designed for portable use by a single operator. The self-centring expandable mandrel provides quick and correct alignment to pipe or tube prior to machining operations.

The Pro 5 PB is able to simultaneously perform 3 of the following operations - external bevel, internal bevel, face off, I.D. chamfer, J-groove bevel, and counterbore.

Available with

Specifications

Pipe machining range:

- 32mm I.D. minimum pipe capacity
- 114mm O.D. maximum pipe capacity
- 140mm O.D. maximum pipe capacity with optional 140mm spindle disc set
- 12mm maximum wall thickness

Package Includes

- PRO 5 PB Bevelling Machine
- Electric or Pneumatic Motor
- Mandrel 32mm I.D. to 107mm I.D.
- 118mm spindle disc
- Set of jaw blocks (1,2,3,4,5,6), 3 sets
- Set of tools
- Coolant container
- Operator's manual



**PRO 5 PB
shown with
electric motor**

Part No.	WA-PR05PBE	WA-PR05PBE
Motor	Pneumatic Motor 800W	Electric Motor 1100W
Rotational Speed	90rpm	gear 1: 0 to 90rpm gear 2: 0 to 300rpm
Air Consumption	1600 l/min (49.4CFM)	-
Weight (incl. PR05PB)	10kg	11kg

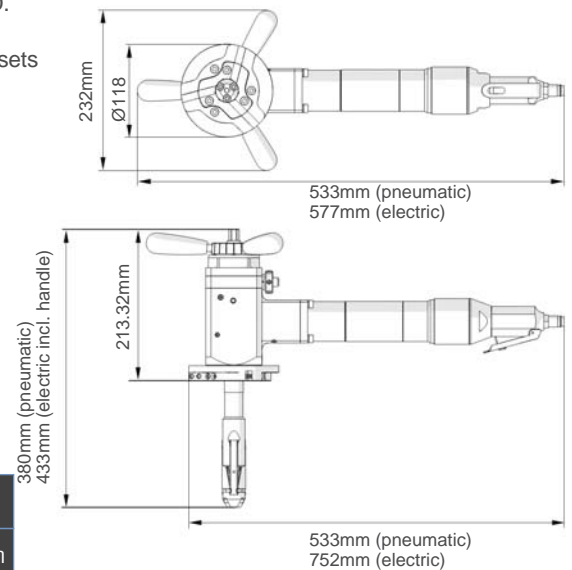

CONSUMABLES

Part No.	Description	Use With Pipe O.D.		
		32 - 56mm	56 - 83mm	83 - 114mm
WAP-B05/B30	External Bevelling HSS Cutting Tip 30°		✓	✓
WAP-B05/B30D	External Bevelling HSS Cutting Tip 30° Deep	✓	✓	
WAP-B05/B37	External Bevelling HSS Cutting Tip 37.5°		✓	✓
WAP-B05/B37D	External Bevelling HSS Cutting Tip 37.5° Deep	✓	✓	
WAP-B05/B45	External Bevelling HSS Cutting Tip 45°		✓	✓
WAP-B05/B45D	External Bevelling HSS Cutting Tip 45° Deep	✓	✓	
WAP-B05/IC1540	Internal Bevelling HSS Cutting Tip 15° For Diameters Under 56mm	✓		
WAP-B05/IC1540/56	Internal Bevelling HSS Cutting Tip 15° For Diameters Over 56mm		✓	✓

Part No.	Description
WAP-B05/BJ20R8	J-Groove Bevelling HSS Cutting Tip 20° R8
WAP-B05/BJ10R6	J-Groove Bevelling HSS Cutting Tip 10° R6
WAP-B05/BJ15R2	J-Groove Bevelling HSS Cutting Tip 15° R2
WAP-B05/F030	Facing HSS Cutting Tip 30mm Width
WAP-B05/BJ15R2	J-Groove Bevelling HSS Cutting Tip 15° R2

ACCESSORIES



75mm Spindle Disc WAP-B05/140

For working in tight spaces of 75mm width or more (standard machine setup requires 118mm or more.) When used in this manner the standard handles must be replaced with a ratcheting wrench.

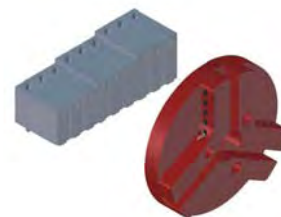

Extension Set WAP-B05/130

Extension set for OD up to 140mm. Including 140mm spindle disc and jaw blocks 3 sets (7, 8, 9)



PRO 5 PB

(continued)

ACCESSORIES



Clamping Ring

WAP-B05/115

Clamping ring for PRO5PB to suit Metabo cordless drill



Small Pipe Mandrel

WAP-B05/150

To suit 25 - 32mm ID pipe

PRO 10 PB PORTABLE PIPE BEVELLER



Overview

The Trademaster PRO 10 PB is a European made I.D. mounted portable pipe beveling machine. Although it is a large capacity heavy duty machine, it can be used efficiently by a single operator, weighing in at a total of just 31.5kg.

The self-centring expandable mandrels provide quick and correct alignment to pipe.

The PRO 10 PB can simultaneously perform 3 of the following operations – internal bevel, external bevel, J-groove bevel, face off, I.D. chamfer and counterbore. Whilst the machine can be operated with just 1 cutting insert, optimal results are achieved by using 3 cutting inserts at once.

The PRO 10 PB is available with either a pneumatic motor or high torque electric motor.

Package Includes

- PRO 10 PB Beveling Machine
- Electric or Pneumatic motor
- Mandrel for pipe 84mm I.D. to 269mm I.D.
- Jaw block set no. 1 to 6
- Toolbox & tools
- Coolant bottle

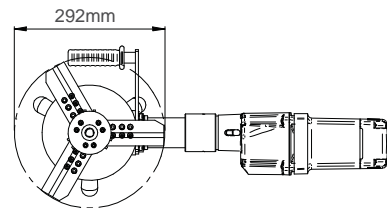
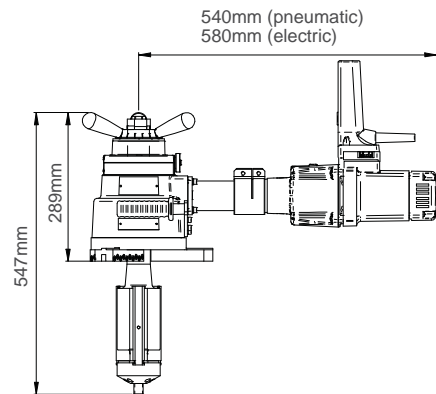

Part No.	WA-PRO10PBA	WA-PRO10PBE
Motor	Pneumatic Motor 1.5kw	Electric Motor 1.8kw
Power Requirements	1750 l/min at 630 kPa	230V/50Hz
Spindle Speed	20rpm	2 Speed Gearbox With Electronic Variable Speed 12 - 28; 41 - 96rpm
Weight (with standard mandrel)	32.0kg	36.0kg

Magnetic Base Drilling Machines

Cutting Tools

Clamps

Engineer's Tools

Sharpening Machines

Metal Cutting Saws

Drilling Machines

Beveling Machines & Welding Carriages

Punches & Shears

Grinding Machines

Fans & Ventilators

Workshop Storage

M7 Airtools

NPK Airtools

Pneumatic Products

PRO 10 PB

(continued)

MACHINE WORKING RANGE

PIPE BEVELLING & FACING RANGE - STANDARD

With standard equipment	PIPE I.D. 84 - 269mm Tooling Reach 292mm
Maximum wall thickness	15mm

PIPE BEVELLING & FACING RANGE - WITH OPTIONAL ATTACHMENTS

With optional Small Expanding Mandrel Set (Part No. WAP-PB10/510)	PIPE I.D. 38 - 86mm Tooling Reach 292mm
With optional Large Expanding Mandrel Set (Part No. WAP-PB10/540)	PIPE I.D. 126 - 296mm Tooling Reach 292mm
With optional Range Increasing Set (Part No. WAP-PB10/550). Recommended for wall thickness up to 7mm	PIPE I.D. 192 - 365mm Tooling Reach 372mm

FLANGE TURNING RANGE - WITH OPTIONAL ATTACHMENTS

With standard mandrel & optional Flange Turning Attachment (Part No. WAP-PB10/520)	PIPE I.D. 84 - 269mm Turning Range 90 - 508mm
With optional Flange Turning Attachment (Part No. WAP-PB10/520) & optional Large Expanding Mandrel Set (Part No. WAP-PB10/540) & optional Range Increasing Set (Part No. PB10/550)	PIPE I.D. 219 - 392mm Turning Range 90 - 508mm

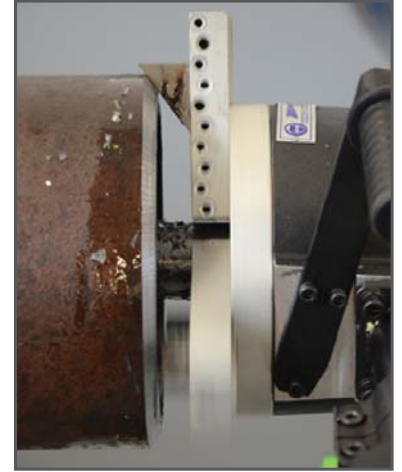

CUTTING INSERTS HIGH SPEED STEEL

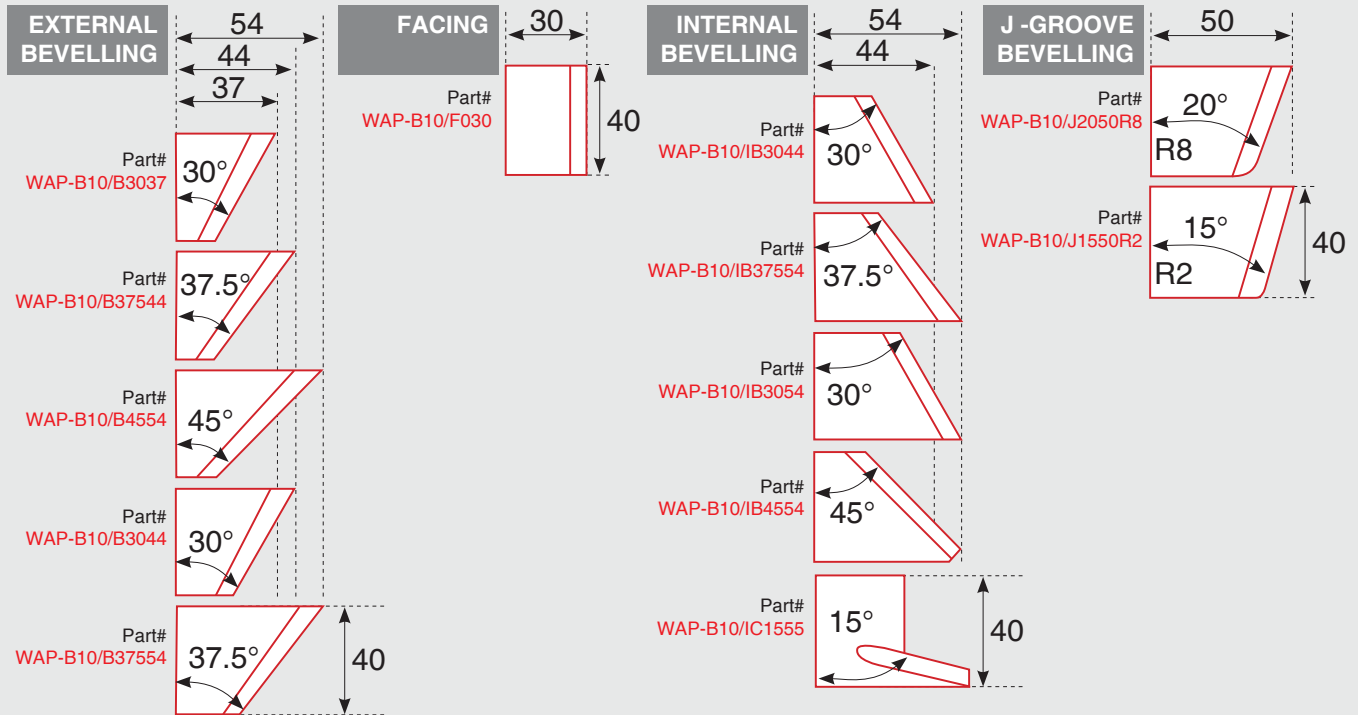

PRO 10 PB

(continued)

OPTIONAL ATTACHMENTS

SMALL EXPANDING MANDREL SET

Part# **WAP-PB10/510**

Specifications

- Enables machining of pipe 38 to 86mm I.D.
- 292mm tooling reach
- Includes jaw blocks No.1 to No.5



RANGE INCREASING SET

Part# **WAP-PB10/550**

Overview

Extension set designed to increase the machining range up to 365mm I.D. Includes 3 steel tool bit holders to increase the tooling reach to 372mm, and jaw blocks No.7 to No.12 to increase the pipe range to 192 - 365mm I.D. Supplied in a metal box.

Specifications

- Enables machining of pipe 192 - 365mm I.D. with standard mandrel fitted
- 372mm tooling reach
- Recommended for wall thickness up to 7mm



OVAL PIPE ATTACHMENT

Part# **WAP-B10/530**

Overview

Attachment for bevelling and facing oval shaped pipe. The spring loaded guide roller rotates on the I.D. of the pipe, and allows the cutting insert to move in and out with the oval pipe up to 15mm.

Specifications

- 84 - 269mm I.D. with standard jaw block set
- 126 - 296mm I.D. with optional Large Expanding Mandrel Set (WAP-B10/540)



FLANGE TURNING ATTACHMENT

Part# **WAP-PB10/520**

Part# **WAP-PB10/520INSERT** (Indexable carbide insert to suit)

Overview

Flange turning attachment using indexable carbide inserts with cutting capacities 90 to 508mm diameter. The machine can mill inwards or outwards at a feed rate of 0.33mm or 0.66mm per revolution, using a bumper system to automatically feed the carbide insert with each revolution of the machine.

Specifications

- Minimum milling diameter : 90mm
- Maximum milling diameter : 508mm
- Feed rate: 0.33mm per revolution using 1 bumper or 0.66mm per revolution using 2 bumpers
- Recommended maximum milling depth : 0.5mm per pass



LARGE EXPANDING MANDREL SET

Part# **WAP-PB10/540**

Overview

Specifically designed to be used with optional Flange Turning Attachment (WAP-PB10/520) & Range Increasing Jaw Block Set (WAP-PB10/550) for flange turning on pipe up to 392mm I.D. and turning range up to 508mm diameter

Specifications

- 126 - 296mm I.D. with standard jaw block set
- 292mm tooling reach



PRO 40 PBS PIPE BEVELLING MACHINE

Overview

The PRO 40 PBS is designed for bevelling and facing pipes, tanks and tubes in a range of diameters from 200mm to 1000mm. A high-speed rotary milling head with replaceable inserts enables effective and efficient machining with bevel widths up to 45mm and angles between 0° and 60°. Internal bevelling and J-groove end preparation is an available option.

An optional Oval Pipe attachment is available for bevelling of pipe which is not truly round.

The use of a heavy duty milling head in the PRO 40 PBS offers accurate bevels in a fraction of the time compared to traditional single point machining. This feature saves time and money as well as improving accuracy.



Part No.	PRO40PBS
Power supply	Single Phase 240V
External pipe diameter range	200-1000mm Pipe Longer Than 830mm; 200-600mm Pipes Of 400-830mm Length
Maximum pipe weight	6 000kg With Standard Plastic Rollers On Active Support 10 000kg With Optional Steel Rollers On Active Support
Min. pipe thickness	5mm
Pipe fixing	Mechanical With Chain
Feed rate	100 - 1100 mm/min
Bevelling angle range	0° - 60° With Continuous Angle Adjustment
Max OD bevel width	45mm
Max ID bevel width	5mm Standard, Up To 20mm - Optional
Bevelling type "J"	YES - Optional
"J" type bevelling radius	6mm or 8mm
Weight	1100kg

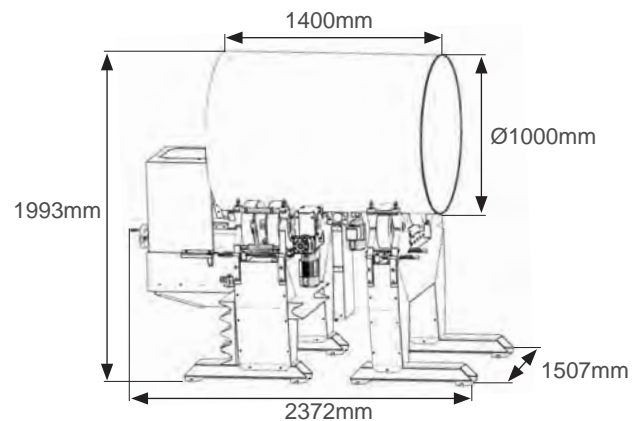

*Dimensions shown are with 1400mm length pipe

Optional Accessories & Consumables

Part No.	Description
WAP-B40/8010	Standard Milling Head
WAP-B020	Replacement Standard Cutting Tips (7 Required)
WAP-B10	Cutting Tips For Hard Steels (7 Required)
WAP-B40/8020	J-Groove R6 Milling Head
WAP-B40/8040	J-Groove R6 Cutting Tip (6 Required)
WAP-B40/8030	J-Groove R8 Milling Head
WAP-B40/8050	J-Groove R8 Cutting Tip (5 Required)
WAP-B40/8090	Oval Attachment

Operations With Optional Heads

J-groove Bevelling

Internal Bevelling

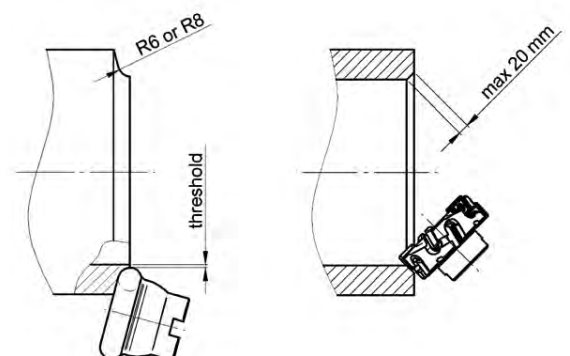

WELDING CARRIAGES

DRAGON CUTTING & BEVELLING OXY - FUEL CARRIAGE

Overview

The Trademaster Dragon is designed to carry a range of oxy-fuel cutting torches with a grip diameter 28 - 35mm, to perform machine quality cutting and beveling processes in a variety of applications.

Features

- Cutting and beveling 0° to 45° (also parallel with 2 torches)
- Quick clamping torch holder for torch diameter 28mm to 35mm
- Advanced speed control system with implemented digital control loop feedback PID regulator
- LED display with readout of actual and set speed, and report messages
- Travel on a rail or directly on a workpiece
- 2-wheel drive with automatic braking drive unit
- Quick drive release switch for easy re-positioning
- Connectable rails to form various lengths
- Rigid and heat-proof design



*Shown with optional track assembly WAP-D6010

Includes

- Dragon carriage
- Torch rack 580mm
- Counterweight 1.3kg
- Torch holder with angle & height adjustment (WAP-D6030)
- Power cord
- Operator's manual

Optional Accessories & Consumables

Part No.	Description
WAP-D6020	Basic Torch Holder
WAP-D6030	Torch Holder with Angle & Height Adjustment
WAP-D6040	Machine Torch Holder
WAP-D6050	Machine Torch Holder with Angle Adjustment
WAP-D6010	Track Assembly
WAP-D6060	Sliding Torch Holder Mount
WAP-D6180	Cable Anchor
WAP-D6190	Carriage Support
WAP-D6160	Large Counterweight
WAP-D6150	Circle Cutting Attachment
WAP-D6170	Extended Torch Rack

Part No.	WA-DRAGON
Power supply	115-230VAC / 50-60Hz
Power	13W
Torch grip diameter	28-35mm
Chassis to material clearance	7.5mm
Travel mechanism	4 Knurled Wheels, 2 Wheel Drive
Guiding equipment	Optional "V" Type Rail With Grooves At 152mm Centres, 1800mm Length (Part# WAP-D6010)
Cutting speed	0-1500mm/min
Chassis dimensions	427mm(L) x 189mm(W) x 180mm(H)
Weight	16.8kg

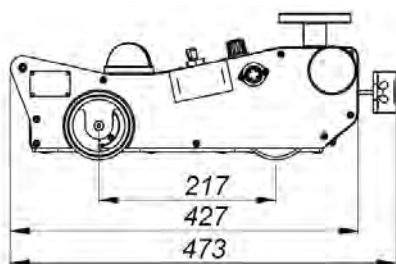
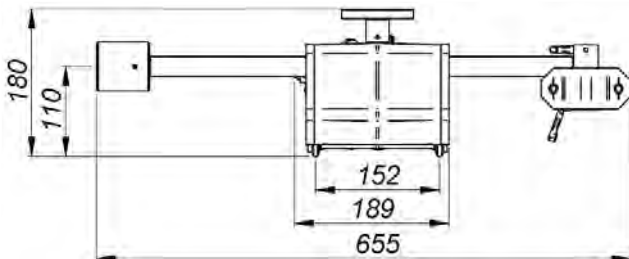

GECKO STANDARD
GECKO HS HIGH SPEED
GECKO BATTERY BATTERY POWERED
FILLET WELDING CARRIAGE

Overview

The Trademaster Gecko is a heavy duty European made portable fillet welding carriage designed to produce consistent high quality welds.

It features a 4-wheel drive system with magnetic traction and a control loop feedback mechanism which provides speed stabilisation in all welding positions.

Constant, continuous and repeatable travel speed enables weld bead geometry that is exact to the required specifications, thus substantially reducing costly over welding and decreasing filler metal usage.

Gecko HS (High Speed) has increased the horizontal maximum speed from 1100mm/min to 2200mm/min. Suitable for both speed welding and plasma cutting.

Features

- Compact & lightweight design with durable aluminum housing
- Permanent magnet clamping system with on/off lever ensures positive magnetic traction
- Maintenance free 4-wheel drive with worm gear reduction
- Quick clamping torch holder mechanism for different types of MIG/MAG torches with diameters of 16-22mm (5/8"-7/8")
- Precise torch adjustment with screw drive cross slide
- Multifunctional LED display - presetting of travel speed, metric & imperial units, error codes information
- Closed loop speed control system stabilises travel speed to reduce weld defects and costly rework
- Consistent heat input reduces distortion
- Automatic ARC ON/OFF system initiates welding with travel, simultaneously
- Self-guiding roller arms eliminate the need for track
- Improves working environment - removes operator from heat and fumes

Battery Powered Model Features

- Supplied with 18V DC 5.2 Ah battery providing 6 hours average operation time (Charger sold separately WAP-G3510)
- Gecko Battery can also be connected to 240V AC mains by means of power supply (Sold separately WAP-G3520)

Standard Part No.	WA-GECKO
High Speed Part No.	WA-GECKOHS
Battery Model Part No.	WA-GECKO-18V
Power supply	115-230VAC / 50-60Hz
Welding positions	Vertical / Horizontal
Chassis to material clearance	4mm
Travel mechanism	Friction Drive With Worm Gear Reduction, 4 Wheel Drive, Heat Resistant Silicone Wheels
Tracking method	2-Guide Rollers
Torch adjustment	Up-Down 35mm, Left-Right 35mm
Gear roller adjustment	100mm
Horizontal speed (GECKO)	0-1100mm/min
Horizontal speed (GECKO - HS)	0-2200mm/min
Vertical speed	0-1000mm/min
Dimensions	240mm (L) x 258mm (W) x 253mm (H)
Weight	8kg (8.6kg battery model)



Package Includes

- Welding carriage
- Torch holder
- Power lead
- 4mm Allen key
- Arc ignition cable
- Operator's manual

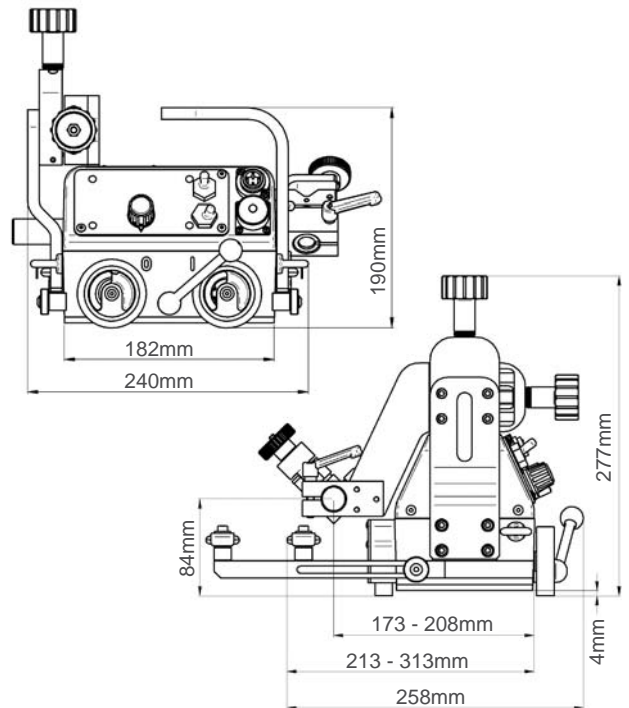

LIZARD PROGRAMMABLE FILLET WELDING CARRIAGE

Overview

The Trademaster Lizard is a heavy duty European made portable welding carriage designed to produce consistently high quality welds.

The Lizard features programmable welding patterns and parameters, and an optional oscillating attachment is available.

The unit enables weld bead geometry that is exact to the required specifications, thus substantially reducing costs.

Features

- Simple to use multifunction LED display for programming welding patterns & parameters including travel speed, weld length, skip length, total length, reverse fill & crater fill time. These settings can be saved, & up to 40 different programs can be stored.
- Continuous and stitch weld capability
- Compact & lightweight design with durable cast aluminum housing
- Permanent magnet clamping system with on/off lever ensures positive magnetic traction
- Maintenance free 4-wheel drive with worm gear reduction
- Friction drive and control loop feedback mechanism provides speed stabilisation in all positions, to reduce weld defects
- Automatic off limit switches on both ends of machine
- Automatic ARC ON/OFF system initiates welding and travel, simultaneously
- Quick clamping torch holder mechanism for different types of MIG/MAG torches with diameters of 16 - 22mm (5/8" - 7/8"); optionally up to 35mm (1-3/8")
- Precise torch adjustment with screw drive cross slide
- Consistent heat input reduces distortion
- Self-guiding roller arms eliminate the need for track
- Improves working environment - removes operator from heat and fumes

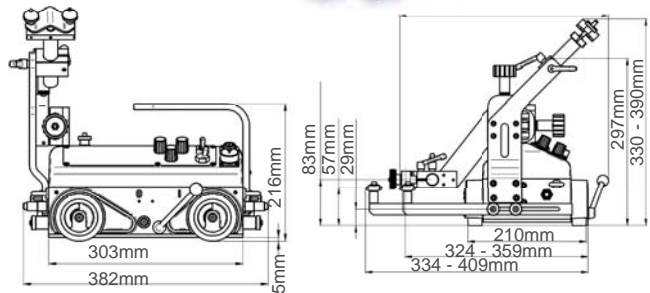

Oscillation Attachment

A critical optional feature of the LIZARD is the oscillation attachment. This attachment significantly increases the functionality of the Lizard welding carriage by allowing it to operate in most out of position applications.

- Oscillation type: Angular max 11°
- Amplitude R - 150mm : 2 - 30mm
- Frequency: 12 - 115 cycles/min
- Delay at ends: 0 - 3 secs
- Weight: 2.5kg
- Part# **WAP-L4000**



Part No.	WA-LIZARD
Power supply	115-230VAC / 50-60Hz
Welding positions	Vertical / Horizontal
Chassis to material clearance	5mm
Travel mechanism	Friction Drive With Worm Gear Reduction, 4 Wheel Drive, Heat Resistant Silicone Wheels
Tracking method	2-Guide Rollers
Torch adjustment	Up-Down 35mm, Left-Right 35mm
Gear roller adjustment	75mm
Horizontal speed	0-1200mm/min
Vertical speed	0-1100mm/min
Dimensions	282mm (L) x 272mm (W) x 390mm (H)
Weight	13.5kg

Package Includes

- Welding carriage
- Power lead
- Arc ignition cable
- Cable holder
- Torch holder
- Lower torch holder
- 4 mm Allen key
- Operator's manual



Gecko & Lizard Accessories

Dual Torch Mount

To suit Gecko & Lizard. Enables mounting of a second torch for dual sided fillet welding.

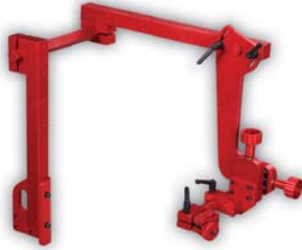

Part No.	Description
WAP-G2010	Dual Torch Mount To Suit Gecko & Lizard

Edge Guide Arms

To suit Gecko & Lizard. Enables guiding off an outside edge.



Part No.	Description
WAP-G2030	Edge Guide Arms To Suit Gecko
WAP-L4010	Edge Guide Arms To Suit Lizard

Adjustable Guide Arms

To suit Gecko & Lizard. Enables guiding on lap joints and templates.



Part No.	Description
WAP-G2040	Adjustable Guide Arms To Suit Gecko
WAP-L4020	Adjustable Guide Arms To Suit Lizard

Follower Guide Arms

To suit Gecko & Lizard. Follower guide arms for flexible track.



Part No.	Description
WAP-G2080	Follower Guide Arms To Suit Gecko
WAP-L4050	Follower Guide Arms To Suit Lizard

Magnetic Block

For use with flexible track.



Part No.	Description
WAP-G2070	Magnetic Block To Suit Flexible Track

Torch Extension Arm

To suit Gecko & Lizard. Enables extended reach for torch placement.

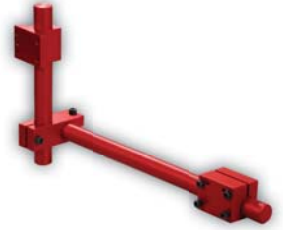

Part No.	Description
WAP-G2020	Torch Extension Arm To Suit Gecko & Lizard

Large Torch Clamp

To suit Lizard. Designed to hold large diameter torches 22 - 35mm.



Part No.	Description
WAP-L4040	Large Torch Clamp To Suit Lizard

Torch Arms

To suit Gecko & Lizard. Designed to be used with torch clamp to hold welding torch.



Part No.	Description
WAP-G2050	110mm Length Torch Arms To Suit Gecko & Lizard
WAP-L4030	230mm Length Torch Arms To Suit Gecko & Lizard

Flexible Track

To suit Gecko & Lizard.



Part No.	Description
WAP-G2060	1825mm Flexible Track To Suit Gecko & Lizard

Torch Clamp Assembly

To suit Gecko.



Part No.	Description
WAP-G2090	Torch Clamp Assembly To Suit Gecko

RAIL BULL TRACK WELDING CARRIAGE WITH OSCILLATOR

Overview

The Rail Bull is a track welding carriage designed to produce butt and fillet welds with or without oscillation. The carriage can work in PA (flat), PB (horizontal vertical), PC (horizontal), PD (overhead horizontal vertical), PE (overhead), PF (vertical-up) and PG (vertical-down) welding positions.

Part No.	WA-RAILBULL
Voltage	1~ 115-230 V, 50-60 Hz 42 V, 50-60 Hz
Power	100W
Welding position (according to EN ISO 6947 and AWS/ASME)	PA / 1F / 1G PB / 2F PC / 2G PD / 4F PE / 4G PF / 3G PG / 3G
Torch diameter	16-22mm; up to 35mm option
Minimum radius of curved workpiece surface	5000mm
Minimum workpiece thickness	5mm
Horizontal pulling force	350N
Vertical pulling force	150N
Cross slide adjustment range	0-35mm up-down, left-right
Horizontal speed	0-120 cm/min
Vertical speed	0-110 cm/min
Weight	20kg
Welding settings storage	1 (last used)
Oscillation type linear	(0 - 100mm)
Oscillation (weaving) pattern	trapezoid, triangle, straight line
Oscillation width	0-50mm
Oscillation speed	0-1500 mm/min
Oscillation delay time	0-5s (at external and central points)



Rail Bull moves along either rigid or semi-flexible track on both ferromagnetic and non-ferromagnetic materials thanks to rack and pinion drive and tracks fixed to flat or curved surfaces by means of various magnetic or vacuum units. The minimum curvature radius required for semi-flexible track is 5m.

Dimensions:

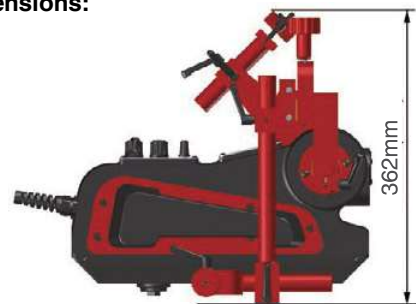

Primary features and benefits:

- Compact, lightweight design with durable aluminum cast housing
- Convenient Power Supply 115-230 V, 50-60 Hz or 42 V, 50-60 Hz
- Quick clamping torch holder mechanism for different types of MIG/MAG torches with diameters of 16-22mm; up to 35mm option
- Precise torch adjustment with screw drive cross slide
- Ready to work in both vertical and horizontal positions
- Multifunctional LED display (process parameters & warnings)
- Consistent heat input reduces distortion
- Reduce wasted filler metal - eliminates over welding
- Automatic arc on/off initiates welding and travel, simultaneously
- Closed loop position control system based on electrical motor with encoder, ensures increased accuracy of speed and positioning
- Improves working environment - removes operator from heat and fumes
- Linear torch oscillator to produce weave welds
- Menu in English (other languages on request)
- Rack and pinion drive
- Continuous welding
- Rigid rail track system



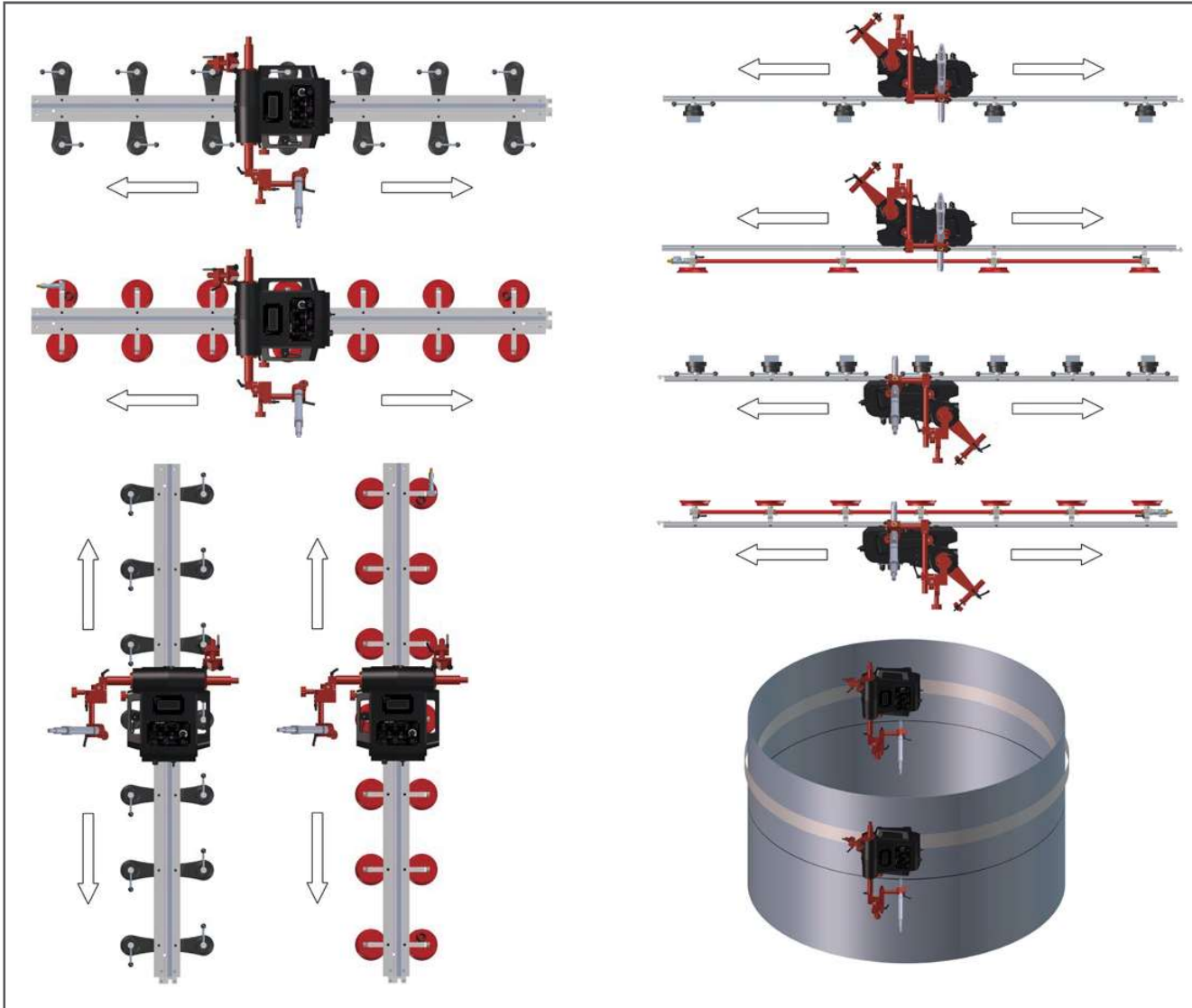
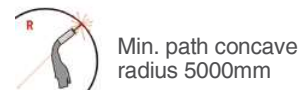
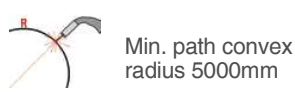
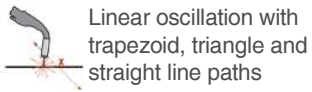
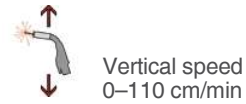
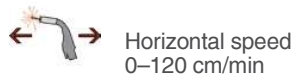
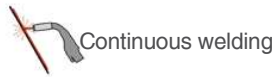

Applications:

- Trailer manufacturing
- Truck tanks
- Oil tanks
- Water storage tanks
- Pressure vessels
- Vessel overlay / Hard facing
- Bridge girders
- Structural steel
- Structural towers
- Panel welding
- Transformers
- Shipyards
- Any application demanding long, continuous welds

Includes:

- Welding carriage
- Metal box
- Cross slide assembly
- Short rod torch holder with clamp
- Cable anchor
- Power cord 3m
- Arc ignition cable of 6.5m
- 3mm hex wrench
- 4mm hex wrench
- Operator's manual



RAIL BULL 2 TRACK WELDING CARRIAGE WITH OSCILLATOR

Overview

The Rail Bull 2 is a track welding carriage designed to produce butt and fillet welds with or without oscillation.

The carriage can work in PA (flat), PB (horizontal vertical), PC (horizontal), PF (vertical up), and PG (vertical down) welding positions.

Rail Bull 2 moves along either rigid or semi-flexible track. Both types of tracks are fixed to flat or curved ferromagnetic surfaces by means of dual magnetic units. The minimum curvature radius required is 5m.



Part No.	WA-RAILBULL2	
Voltage	1~230 V, 50-60 Hz 1~115 V, 50-60 Hz 1~ 42 V, 50-60 Hz	
Power	120W	
Welding position (according to EN ISO 6947 and AWS/ASME)		PA / 1F / 1G
		PB / 2F
		PC / 2G
		PD / 4F
		PE / 4G
		PF / 3G
		PG / 3F (contact your dealer)
		PG / 3G
Fixing on pipes and round workpieces	Ring tracks	from 200mm OD up to 3m OD
	Custom rolled tracks	from 3m OD up to 10m OD
	Semi-flexible track	Minimum curvature radius of 5m
Torch type	MIG/MAG, TIG, Plasma, Oxy-fuel	
Torch diameter	16-22mm up to 35mm option	
Horizontal pulling force	400N	
Vertical pulling force	300N	
Horizontal speed	0-300 cm/min	
Vertical speed	0-300 cm/min	
Oscillation type	Linear	
Weld path	Straight, triangle, trapezoid, square	
Oscillation width	0.2-11.8cm	
Oscillation speed	10-300cm/min	
Oscillation dwell time at center and on ends	0-5s	
Weight	10kg	

Dimensions:



Primary features and benefits:

- Fully modular mechanized travel carriage can be custom configured for a variety of welding, thermal cutting and gouging applications on flat or curved plate, tube and pipe
- Linear torch oscillator to produce weave welds
- Active compensation of torch position vertically and horizontally by means of modular automatic seam tracking system
- Programmable path of stitch welds
- Possibility to select one limit switch preset out of three presets available.
- Suitable for variety of circumferential and irregular surface applications down to minimum radius of 100mm
- - Ring tracks on diameters from 200mm OD up to 3m OD
- - Custom rolled tracks on diameters from 3m OD up to 10m OD
- - Semi-flexible tracks can be flexed to minimum radius of 5m without permanent deformation
- Ergonomic remote control pendant with simple and easy to find control knobs makes adjustments possible without lifting of the operators welding hood
- Magnetic adhesion of the pendant provides firm grip on ferromagnetic materials
- Suitable for all welding positions on both ferromagnetic and non-ferromagnetic materials thanks to rack and pinion drive and various tracks equipped with magnetic or vacuum units
- Rail Bull 2 produces consistent high quality welds and cuts in a fraction of the time required by manual operations
- High speed up to 3m/min makes plasma cutting available



Linear oscillation with trapezoid, triangle, square and straight line paths



Ring tracks from 200mm OD up to 3m OD



Custom rolled tracks from 3m OD up to 10m OD



Min. path convex radius for semi-flexible tracks is 5m



Continuous welding



Stitch welding



Horizontal speed 10–300 cm/min



Vertical speed 10–300 cm/min

Rail Bull 2 can work in all welding positions on both ferromagnetic and non-ferromagnetic materials by using rack and pinion drive and various tracks equipped with magnetic or vacuum units.

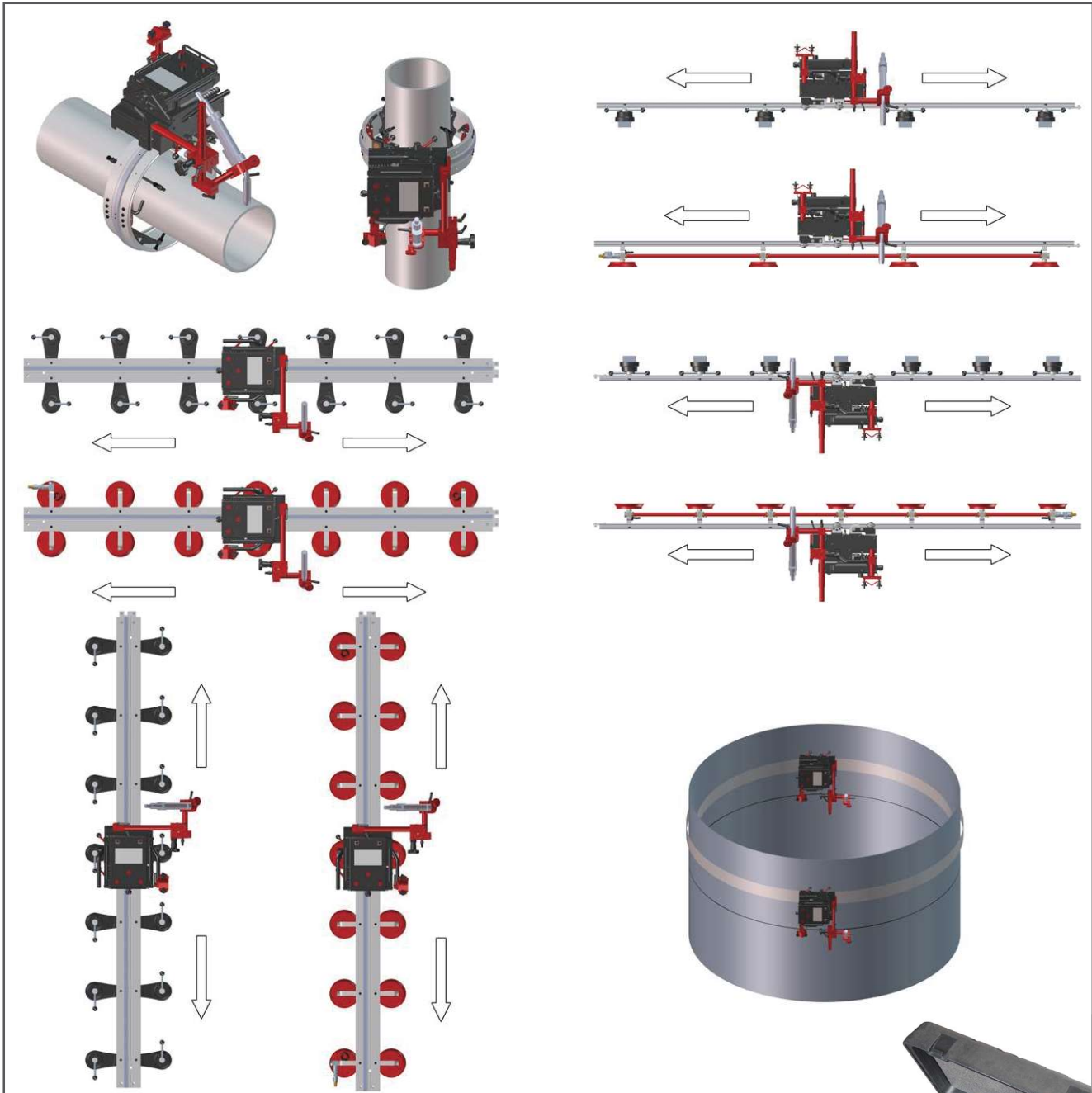

Includes:

- Welding carriage
- Power supply
- 5m power cable
- Remote control pendant
- 3m remote control cable
- 6.5m arc ignition cable
- 300mm rod
- 300mm rack
- Rackholder
- Clamping block with levers
- Short rod torch holder with fits-all clamp
- Cable anchor
- Contact block
- 6mm hex wrench
- Operator's Manual



Magnetic Base Drilling Machines

Cutting Tools

Clamps

Engineer's Tools

Sharpening Machines

Metal Cutting Saws

Drilling Machines

Bevelling Machines & Welding Carriages

Punches & Shears

Grinding Machines

Fans & Ventilators

Workshop Storage

M7 Airtools

NPK Airtools

Pneumatic Products

**PPCM 650
PIPE PROFILE CUTTING
MACHINE**



Overview

The CNC controlled Pipe Profile Cutting Machine allows wide working range from diameters 50 to 650 mm and pipe lengths between 6000 mm and 12000 mm using oxy-fuel or plasma.

Advanced design and top quality components enable fast and efficient cutting with top quality results. The most important feature and advantage is it's user friendly software which enables quick understanding and efficient use of this machine after a short training session without any need of investment in costly CAD/CAM software.

Pipe Profile Cutting Machine can be customised according to customer preferences



Part No.	WA-PPCM650
Pipe O.D.	50 - 650mm
Max. pipe length	6000mm
OPTIONS:	Extensions of tracks up to 12000mm
Max. through spindle diameter	133mm
Admissible ambient temperature	5 - 50°C
Fixed height main drive	YES
Opening and closing	Manual with self-centring 3 jaw chuck
Pipe support	2 pcs., max. load 2[T] /each
OPTION:	Additional supports on request
Vertical oval compensation mechanism	Included
Ignition	Manual
Reference laser marker	Included
Menu language	English
OPTION:	Other languages are optional
Fume exhaust system	Optional
Total consumption 3~ 400 V ±10% + PE + N, 50/60 Hz ±4%	12KVA
Transfer of NC data from Tekla Structures	Optional

MCM 5 AXIS PORTABLE SHAPE CUTTING AND WELDING MACHINE

Overview

MCM machines perform automatic oxy-fuel or plasma cutting / bevelling and single or double bevel butt welds for wind towers (door frames), pressure vessels (nozzles), pipes, tanks, various steel structures with MCM SAW welding (recommended). MCM machines produce perfect welding joints, root face and root gap with top quality surface. MCM machines save time for welding and minimize use of welding consumables and minimize weld defects thanks to MCM SAW technology.

The MCM can also be used on flat, horizontal, vertical, convex, concave surfaces, pipes and tanks. The MCM machine allows both sided oxy-fuel or plasma hole cutting and bevelling in one fixed position.

Optionally the MCM machine can be equipped with welding equipment according to customers' preference.

Features

- Cutting, bevelling and welding of a door frame from the one position
- Capability to cut an opening which exactly matches the specific door frame to be installed
- Extremely accurate and consistent root gap, root face, and bevel angle
- No CNC programming required
- Simple and user friendly interface enables an easy input and configuration of the cutting/bevelling parameters. The innovative control system and software allows for double-sided bevelling in one operation and ensures precise movement of the cutting torch. The cutting torch's position actively correlates to the curvature of the work piece
- Cutting/bevelling/welding on flat, concave, convex and conical surfaces is also available
- Machine is fully portable
- Uses multi language, user friendly control system interface
- Custom made versions are available
- Welding equipment from different manufacturers can be integrated with the MCM system
- Welding process is performed in an automatic cycle with possibility of manual adjustment of the welding gun

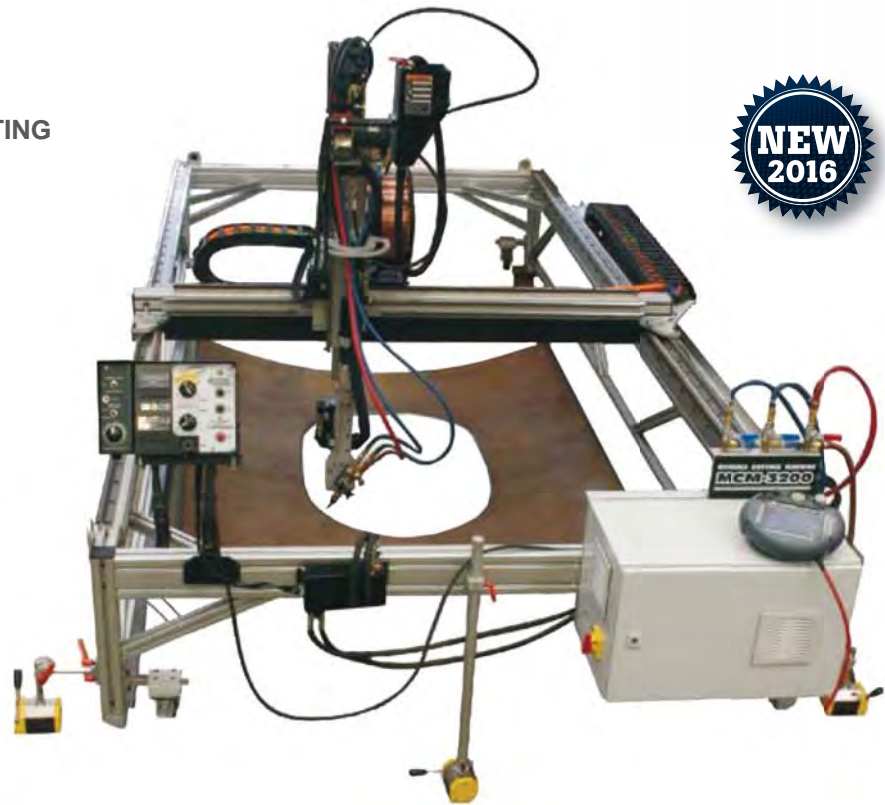
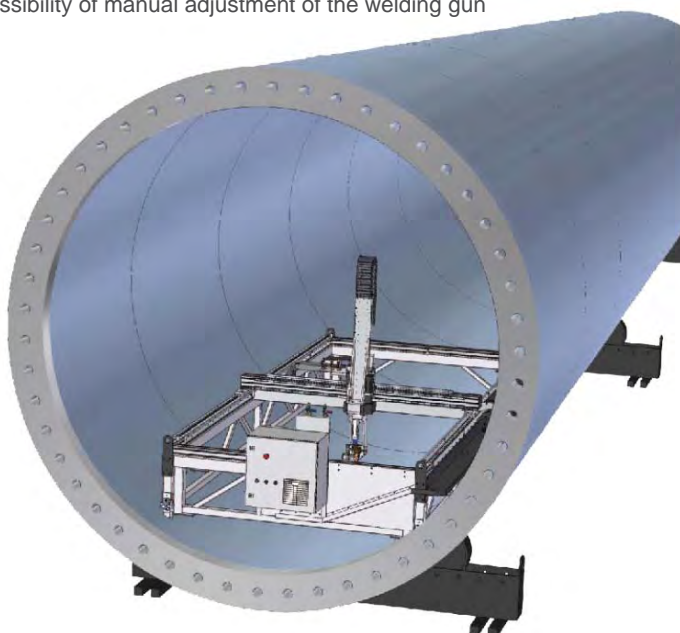

Part No.	WA-MCM3200S
Power supply	230V (+10%, -5%), 50/60Hz
Minimum pipe diameter	3000mm, also suitable for flat surfaces
Maximum hole length	3200mm
Maximum hole width	1200mm
Maximum bevelling angle	45 degrees
Maximum bevel width B	45mm
Maximum process speed	2.0m/min
Weight (w/o welding equipment)	630kg
Overall machine dimensions: L x W x H	4685 x 2280 x 1800mm
Number of axes	5
Oxy - fuel cutting	YES
Transport frame	YES
Mobile control panel	YES
Maximum wire electrode diameter	3.2mm (recommended)

WA 500 / 1000 GMAW HALF GANTRY BEAM WELDING SYSTEM

Overview

The WA 500 / 1000 GMAW machine is intended for the longitudinal welding of structural beams with web in vertical or horizontal positions, and includes mechanical automated seam tracking system.

Features

- 5 numerically controlled axes with mechanical tracking system and active compensation of position of both torches with regards to the welding seam
- Use of precise gears and rack-and-pinion as well as ball bearing guide rails in X, Y and Z axes, guarantees precise travel with stable and repeatable welding processes.
- User friendly interface
- Idle run speed up to 4 m/min

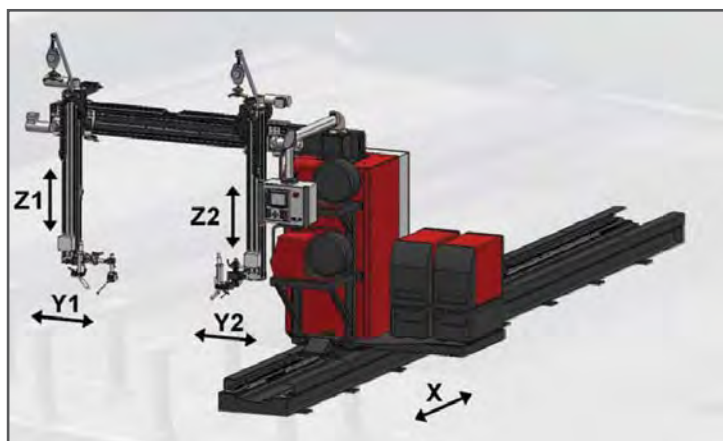

2620 - 3100mm

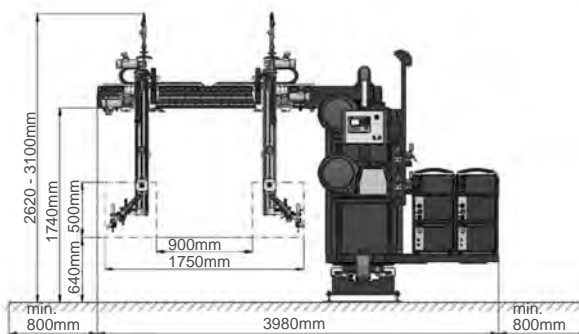
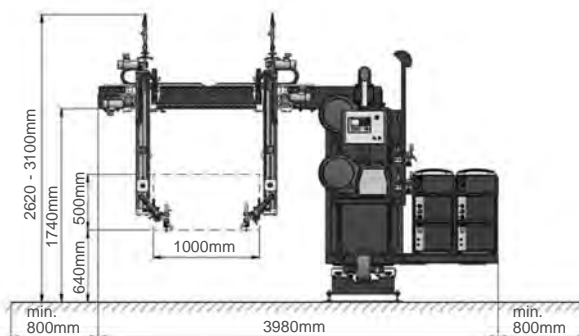

Part No.	WA-500 / 1000 GMAW
Length of track – X axis/ longitudinal welding	7m / 6m, extension in 3-meter sections - optional
Torch range in Z axis	500mm
Torch range in Y axis	1000mm
Maximum distance between torches	1700mm
Torch travel speed	From 0,1 up to 4m/min
Types of welds	Continuous Stitch - optional
Possibility to implement additional functionality e.g. welding length, intermittent welds	YES
Portable remote controller	YES
Device status messages	YES
Welding sources up to 89kg (196 lbs)/ each can be installed on the machine *	As required
Wire feeder	As required



PUNCHES & SHEARS

Manual Shears	202
Manual Punches	202
Hydraulic Punches	203

MANUAL SHEARS

PLATE & BAR SHEAR

Hand Shear Machines suitable for cutting sheet steel, plate, flat bar & rod.

- Frame is made of quality SS41 Steel
- Blades are made of SKS tool steel
- Long handle is supplied with machine



Part #	ES3SR120	ES3SR300	ES3SG250
	4mm	4mm	7mm
	70 x 5mm	70 x 6mm	80 x 7mm
	10mm	13mm	16mm
	120mm	300mm	250mm
	8.3kg	29.8kg	43.5kg

PLATE, BAR & SECTION SHEAR

Hand Shear Machine suitable for cutting sheet steel, plate, flat bar, rod & angle iron.

- Frame is made of quality SS41 Steel
- Blades are made of SKS tool steel
- Long handle is supplied with machine



Part #	ES4SS406
	8mm
	100 x 10mm
	16mm
	40 x 6mm
	40 x 6mm
	200mm
	46.6kg

MANUAL PUNCHES

PUNCHES

Manual Punch Machines designed for punching round, square, rectangular & elliptical shapes. Long handle is supplied with machine.



Part #	EPPR1006	EPPR1208	EPPR1610
Diameter Capacity	10mm	12mm	16mm
Depth Capacity	6mm	8mm	10mm
Throat Depth	80mm	120mm	160mm
Weight kg	11.3kg	33.4kg	62.5kg

Note : The capacity ratings shown are supplied by the manufacturer as maximum capacities. Achievable capacities in normal working conditions on mild steel may be less.



PUNCHES & DIES

Part #	EPPR1006	EPPR1208	EPPR1610
PUNCHES			
4mm	EPPR1006P/4	EPPR1208P/4	-
5mm	EPPR1006P/5	EPPR1208P/5	-
6mm	EPPR1006P/6	EPPR1208P/6	EPPR1610P/6
8mm	EPPR1006P/8	EPPR1208P/8	EPPR1610P/8
10mm	EPPR1006P/10	EPPR1208P/10	EPPR1610P/10
11mm			EPPR1610P/11
12mm	-	EPPR1208P/12	EPPR1610P/12
13mm			EPPR1610P/13
14mm	-	-	EPPR1610P/14
16mm	-	-	EPPR1610P/16
DIES			
3 & 4mm	EPPR1006D/3-4	EPPR1208D/3-4	-
5 & 6mm	EPPR1006D/5-6	EPPR1208D/5-6	-
6 & 8mm			EPPR1610D/6-8
7 & 8mm	EPPR1006D/7-8	EPPR1208D/7-8	-
8 & 10mm	EPPR1006D/8-10	-	-
9 & 10mm	-	EPPR1208D/9-10	EPPR1610D/9-10
10mm	EPPR1006D/10-10	-	-
10 & 12mm	-	EPPR1208D/10-12	-
11 & 12mm	-	-	EPPR1610D/11-12
12 & 13mm	-	EPPR1208D/12-13	-
13 & 14mm	-	-	EPPR1610D/13-14
13 & 16mm	-	-	EPPR1610D/13-16

HYDRAULIC PUNCHES

HOLEMAKER PRO 60 HP HOLEMAKER PRO 110 HP PORTABLE DOUBLE ACTION HYDRAULIC PUNCHES

Features

- Quality European manufacture
- Double action hydraulic punches
- Wide range of hole diameters up to 27mm
- Heavy duty fabricated steel construction
- Intelligent control system with inching and automatic load detection
- Mode indicator light
- Protection against accidental start-up
- Easy to handle both in and out of working positions
- All connecting ports located at the rear of machine
- Wide range of special-shaped punches and dies available on request
- Can be used with Double Action Hydraulic Power Pack HPP 700



Ergonomic location of hydraulic connections on rear of machine



PRO 60 HP



PRO 110 HP

Technical Data

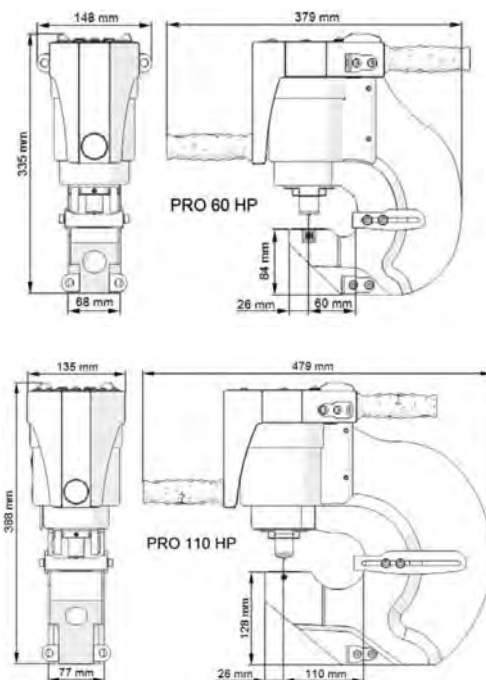

Part No.	WA-HPPRO60HP	WA-HPPRO110HP
Max. Plate Thickness	13mm	16mm
Max. Throat Depth	60mm	110mm
Max. Hole	Ø 27mm	Ø 27mm
Max. Oval Hole	25 x 18mm	25 x 18mm
Punching Time	5 seconds	8 seconds
Punching Power	35 ton	47 ton
Working Pressure	10152 PSI	10152 PSI
Weight	20kg	35kg

**SPIRAL SPRING
BALANCERS
AVAILABLE.
SEE PAGE 268**



Magnetic
Base
Drilling
Machines

Cutting
Tools

Clamps

Engineer's
Tools

Sharpening
Machines

Metal
Cutting
Saws

Drilling
Machines

Bevelling
Machines
& Welding
Carriages

Punches
& Shears

Grinding
Machines

Fans &
Ventilators

Workshop
Storage

M7
Airtools

NPK
Airtools

Pneumatic
Products

Holemaker®

HOLEMAKER HPP 700 DOUBLE ACTION HYDRAULIC POWER PACK

Features

Quality European manufacture. Portable Hydraulic Power Pack, suitable for use with Holemaker Portable Double Action Hydraulic Punches. The HPP 700 features a shelf for conveniently transporting the punch.



Pictured with the Holemaker PRO 110 HP Portable Double Action Hydraulic Punch.



Ideal for portable use.

Part No.	WA-HPP700
Power Supply	240V
Motor Power	1500 W
Working Pressure	10152 PSI
Pump Output	1.5L/min
Oil Capacity	10 L

STATIONARY WORK SET WITH FOOT PEDAL

Foot pedal machine control in hands free operation on bench top configuration.



Part No.	Description
WA-HPP1020	Stationary Work Set With Foot Pedal To Suit Holemaker Portable Punches

HOIST SET

Allow for easy manipulation of punch and power pack as single unit.

- Includes:
- 1x Hoist arm
- 2x Support wheels

Pictured with the Holemaker PRO 110 HP and Holemaker HPP 700 (not included.)



Part No.	Description
WA-HPP1010	Hoist Set To Suit WA-HPP700

ROLLER GUIDE

Provides smooth and efficient lineal movement along the workpiece.

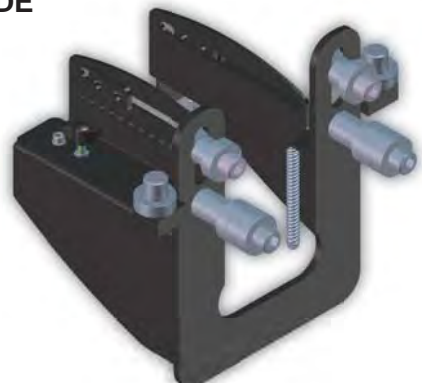

Part No.	Description
WA-HPP1030	Roller Guide To Suit Holemaker Portable Punches

5° INCLINED ROUND DIE TO SUIT HOLEMAKER PRO 60 HP & PRO 110 HP



Size	Die Part No.
9mm	HPRD09A
10mm	HPRD10A
11mm	HPRD11A
12mm	HPRD12A
13mm	HPRD13A
14mm	HPRD14A
15mm	HPRD15A
16mm	HPRD16A
17mm	HPRD17A
18mm	HPRD18A
19mm	HPRD19A
20mm	HPRD20A
21mm	HPRD21A
22mm	HPRD22A
23mm	HPRD23A
24mm	HPRD24A
25mm	HPRD25A
26mm	HPRD26A
27mm	HPRD27A

OBLONG PUNCH & DIE TO SUIT HOLEMAKER PRO 60 HP & PRO 110 HP



Size	Punch Part No.	Die Part No.
16 x 8mm	HPOP1608	HPOD1608
18 x 9mm	HPOP1809	HPOD1809
18 x 11mm	HPOP1811	HPOD1811
20 x 10mm	HPOP2010	HPOD2010
20 x 12mm	HPOP2012	HPOD2012
20 x 14mm	HPOP2014	HPOD2014
22 x 11mm	HPOP2211	HPOD2211
22 x 14mm	HPOP2214	HPOD2214
24 x 12mm	HPOP2412	HPOD2412
25 x 9mm	HPOP2509	HPOD2509
25 x 12mm	HPOP2512	HPOD2512
25 x 13mm	HPOP2513	HPOD2513
25 x 14mm	HPOP2514	HPOD2514
25 x 18mm	HPOP2518	HPOD2518

ROUND PUNCH & DIE TO SUIT HOLEMAKER PRO 60 HP & PRO 110 HP



Size	Punch Part No.	Die Part No.
7mm	HPRP07	HPRD07
8mm	HPRP08	HPRD08
9mm	HPRP09	HPRD09
10mm	HPRP10	HPRD10
11mm	HPRP11	HPRD11
12mm	HPRP12	HPRD12
13mm	HPRP13	HPRD13
14mm	HPRP14	HPRD14
15mm	HPRP15	HPRD15
16mm	HPRP16	HPRD16
17mm	HPRP17	HPRD17
18mm	HPRP18	HPRD18
19mm	HPRP19	HPRD19
20mm	HPRP20	HPRD20
21mm	HPRP21	HPRD21
22mm	HPRP22	HPRD22
23mm	HPRP23	HPRD23
24mm	HPRP24	HPRD24
25mm	HPRP25	HPRD25
26mm	HPRP26	HPRD26
27mm	HPRP27	HPRD27

CUSTOM SHAPE PUNCH & DIE TO SUIT HOLEMAKER PRO 60 HP & PRO 110 HP



Custom shape punches and die sets are now available for use with Holemaker PRO 60 HP and PRO 110 HP. Contact ITM regarding your required shape punches and dies.



Custom shapes must fit within max 27mm diameter circle.



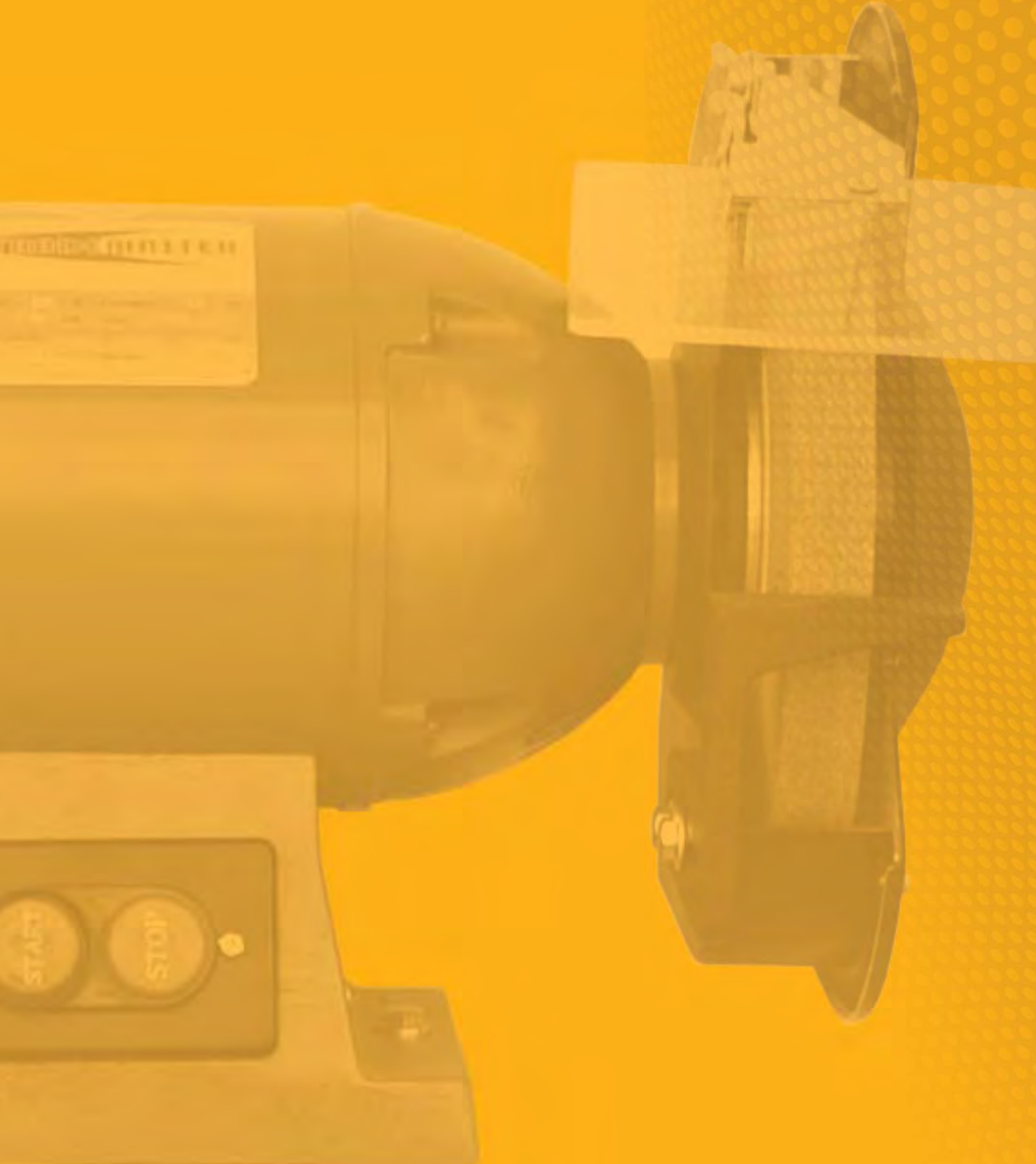

GRINDING MACHINES

Bench Grinders	207
Belt Grinders	208
Pipe Notchers	209

BENCH GRINDERS EXTRA HEAVY DUTY

Features

- High quality robust construction, made in Taiwan, designed to give long service life in demanding industrial workplaces
- All machines include adjustable eye shields and grinding wheels
- High powered motor rated at it's true output power
- Fully balanced motor providing smooth operation
- Capacitor start and run provides instant startup and running power
- Available with Non Voltage Return (NVR) safety switch, which stops machine from re-starting after workshop power failures

8" BENCH GRINDERS



Part #	GR801B	GR801A	GR803A
Wheel Diameter	200mm (8")	200mm (8")	200mm (8")
Wheel Width	25mm	25mm	25mm
Bore	15.9mm	15.9mm	15.9mm
Motor Power	1HP (0.75kW)	1HP (0.75kW)	1HP (0.75kW)
Voltage	240V	240V	415V 3 Phase
Speed	2850rpm	2850rpm	2850rpm
Weight	18.5kg	18.5kg	18.5kg
Thread Size	5/8" BSW	5/8" BSW	5/8" BSW
Switch	Standard	NVR Switch	NVR Switch

BENCH GRINDER STANDS



Part No.	Description
GR1001ST	Stand To Suit 8" & 10" Bench Grinders
GR1203ST	Stand To Suit 12" Bench Grinder

10" BENCH GRINDER



Part #	GR1003
Wheel Diameter	250mm (10")
Wheel Width	25mm
Bore	25.4mm
Motor Power	1.3HP (1.0kW)
Voltage	415V 3 Phase
Speed	1420rpm
Weight	37.5kg
Thread Size	1" BSW
Switch	NVR Switch

12" BENCH GRINDER



Part #	GR1203
Wheel Diameter	300mm (12")
Wheel Width	50mm
Bore	25.4mm
Motor Power	2HP (1.5kW)
Voltage	415V 3 Phase
Speed	1720rpm
Weight	80.0kg
Thread Size	1" BSW
Switch	NVR Switch

Magnetic Base Drilling Machines

Cutting Tools

Clamps

Engineer's Tools

Sharpening Machines

Metal Cutting Saws

Drilling Machines

Bevelling Machines & Welding Carriages

Punches & Shears

Grinding Machines

Fans & Ventilators

Workshop Storage

M7 Airtools

NPK Airtools

Pneumatic Products

TM400-150 150MM INDUSTRIAL BENCH GRINDER

- Powerful 370W induction motor
- 25mm width grinding wheels with 36 & 60 grit for fast removal of material
- Cast iron body and base for long lasting performance
- Vibration absorbing pads on base for smoother operation
- Capacitor start-stop motor for maximum performance
- Fully adjustable tool rests for ease of use and maximum user control
- Large eye shields for increased user safety



TM400-250 250MM INDUSTRIAL BENCH GRINDER

- Powerful 900W induction motor
- 25mm width grinding wheels with 36 & 60 grit for fast removal of material
- Cast iron body and base for long lasting performance
- Vibration absorbing pads on base for smoother operation
- Capacitor start-stop motor for maximum performance
- Fully adjustable tool rests for ease of use and maximum user control
- Large eye shields for increased user safety



TM400-200 200MM INDUSTRIAL BENCH GRINDER

- Powerful 600W Induction Motor
- 25mm width grinding wheels with 36 and 60 grit for fast removal of material
- Cast iron body and base for long lasting performance
- Vibration absorbing pads on base for smoother running
- Capacitor Start-Stop motor for maximum performance
- Heavy Duty tool rests for maximum user control
- Large eyes shields for increased user safety



TM402-200 200MM INDUSTRIAL BUFFING MACHINE

- Powerful 550W Induction Motor
- Safety lock On/Off switch
- Cast iron body and base for long lasting performance
- Vibration absorbing pads on base for smoother running
- Capacitor Start-Stop motor for maximum performance
- Includes 200mm x 14mm stitched polishing mops



Part No.	Motor Power	Voltage	Speed	Wheel / Polishing Mop	Spindle Thread	Weight
	m		RPM	mm	mm	kg
TM400-150	370W	240V, 50Hz	2850	150 x 25mm	M12 x 1.75mm	11.1
TM400-200	600W	240V, 50Hz	2850	200 x 25mm	M16 x 20mm	16.7
TM400-250	900W	240V, 50Hz	2850	250 x 25mm	M16 x 20mm	23
TM402-200	550W	240V, 50Hz	2850	200 x 14mm	M16 x 20mm	11.5
Part No.						
TM403-010	Bench Grinder Stand, 11.5kg, For Use With TM400-150, TM400-200, TM400-250, TM402-200					
TM403-012	Premium Bench Grinder Stand, 14kg, For Use With TM400-150, TM400-200, TM400-250, TM402-200					



BELT GRINDERS

GRIMAX BELT GRINDERS

High Quality Robust Machine from Denmark. Smooth efficient metal grinding up to 10 times faster than conventional stone grinders. 5 year motor warranty

Features

- Smooth, low vibration high output operation
- Solid 5mm thick plate work rest with multi-position system
- 2860rpm Belt Speed enables fast & efficient metal removal
- Simple & precise belt tracking adjustment
- Durable 90 durometer rubber contact wheel
- Emergency Stop NVR safety switch



• Simple Tracking System • Platen Grinding Surface • Emergency Stop Switch



Part #	GRIMAX75	GRIMAX150
Motor	3.0KW 415V 3 Phase	3.6KW 415V 3 Phase
Contact Wheel	200 x 75mm	200 x 150mm
Platen Surface	540 x 75mm	540 x 150mm
Grinding Belt	2000 x 75mm	2000 x 150mm
Weight	86kg	110kg

TRADEMASTER BELT GRINDER

Features

- Low vibration running is achieved by the extra heavy duty robust construction, with sturdy workbase, & 14mm thick plate mainframe
- Solid 5mm thick plate work rest with multi-position system
- Simple & precise belt tracking adjustment
- Durable 90 durometer rubber contact wheel
- Stainless steel fastenings
- Emergency stop NVR switch

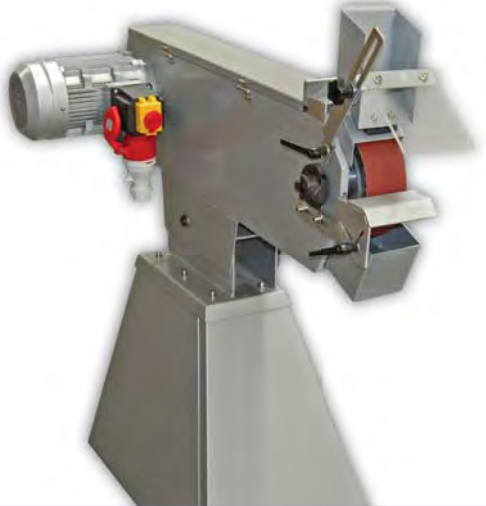

Part #	TBG75
Motor	2.2KW 415V 3 Phase
Contact Wheel	200 x 75mm
Platen Surface	590 x 75mm
Grinding Belt	2000 x 75mm
Weight	125kg

TRADEMASTER BELT GRINDER

Features

- Quality, durable construction, made in Taiwan
- 240 Volt industrial motor
- Smooth, low vibration operation
- Large sturdy base



Part #	GS4591C
Motor	1.5KW 240V Single Phase
Contact Wheel	170 x 100mm
Platen Surface	405 x 100mm
Grinding Belt	1500 x 100mm
Weight	74kg

PIPE NOTCHERS

GRIMAX PIPE NOTCHERS

High quality robust machine made in Denmark, smooth & efficient metal grinding & notching. 5 year motor warranty.

Features

- Smooth, low vibration high output operation
- Notches pipe & tubing between 30° & 90° angles
- Platen grinding surface
- Solid 5mm thick plate work rest with multi-position system
- Simple & precise belt tracking adjustment
- Durable 90 durometer rubber contact wheel
- Emergency stop NVR safety switch
- Package includes machine, 42mm roller, grinding belt

Available Accessories

- Pipe notcher to belt grinder conversion kit
- Holder for contact rollers
- Exhaust extraction unit
- Extra rollers



• Notching In Process

• Notching Vice

• Grinder Conversion Kit

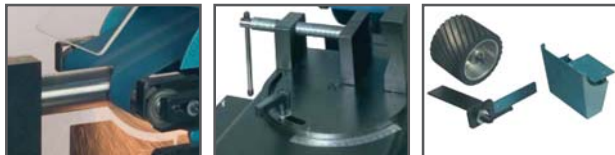

Part #	GRIMAX75BR	GRIMAX150BR
Motor	3.6KW 415V 3 Phase	3.6KW 3 415V 3 Phase
Flat Surface	605 x 75mm	605 x 150mm
Grinding Belt	2000 x 75mm	2000 x 150mm
Vice	30° - 90° Swivel Vice	30° - 90° Swivel Vice
Pipe O.D Capacity	17 - 70mm	17 - 100mm
Weight	126kg	150kg

TRADEMASTER PIPE NOTCHER

A fast, inexpensive & accurate way to notch pipe & tubing between 30° & 90° angles.

Features

- Smooth, high output motor
- Platen grinding surface
- Low vibration running is achieved by the extra heavy duty robust construction, with sturdy workbase, & 14mm thick plate mainframe
- Stainless steel fastenings
- Emergency stop NVR safety switch
- Package includes :
 - Pipe Notching Machine
 - Roller t/s 20mm N.B Pipe
 - Roller t/s 25mm N.B Pipe
 - Roller t/s 32mm N.B Pipe
 - Roller t/s 40mm N.B Pipe
 - Roller t/s 50mm N.B Pipe
 - Grinding Belt
 - Toolbox



Part #	TBN075
Motor	2.2KW Single Phase 240V
Flat Surface	590 x 100mm
Grinding Belt	2000 x 100mm
Vice	30° - 90° Swivel Vice
Pipe O.D Capacity	17 - 70mm
Weight	170kg

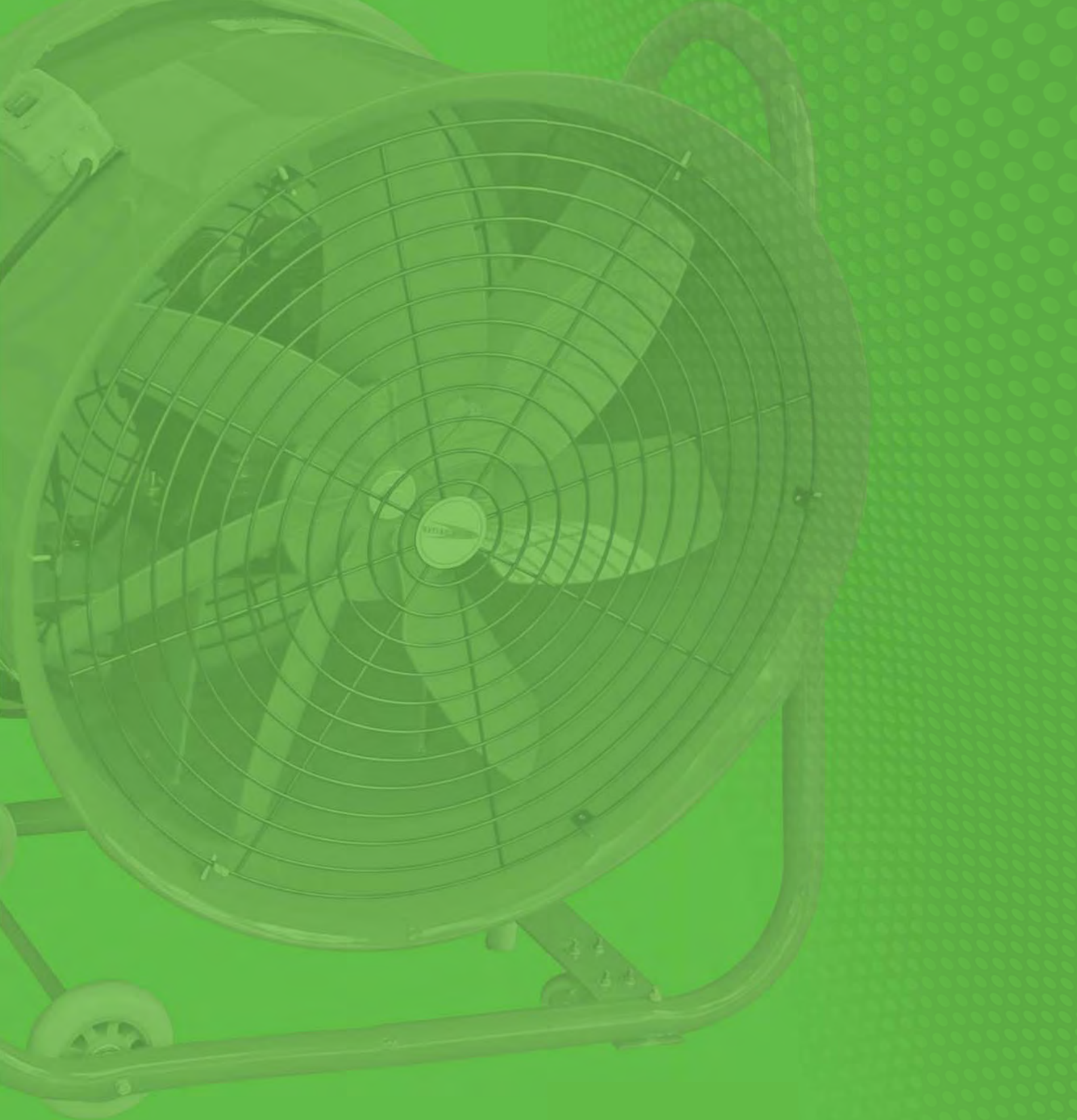

FANS & VENTILATORS

Industrial Fans 211

Portable Ventilators 212

INDUSTRIAL FANS

INDUSTRIAL WORKSHOP FANS

- Quality robust construction designed for everyday use in industrial workshops
- Zinc coated mesh
- Powder coated steel frame
- High output & quiet running 3 speed motor
- Oscillating function



PEDESTAL FAN

Part #	TPF24	TPF30
Description	Pedestal Fan	Pedestal Fan
Blade Diameter	600mm (24")	750mm (30")
Motor	240V 3 Speed	240V 3 Speed
Flow Rate	185m ³ /min	290m ³ /min

SUPER HEAVY DUTY INDUSTRIAL FANS

- Super heavy duty industrial fans manufactured to our requirements in Taiwan
- Superior output & low noise
- The high output & quiet running is due to the 4 x 165mm steel fan blades
- The motors are finned industrial quality
- Oscillating function



PEDESTAL FAN

Part #	JSP24FAN/OS
Description	Pedestal Fan
Blade Type	4 x 165mm Width Steel
Blade Diameter	600mm (24")
Motor	240V Single Speed



WALL MOUNT FAN

Part #	TWF30
Description	Wall Mount Fan
Blade Diameter	750mm (30")
Motor	240V 3 Speed
Flow Rate	290m ³ /min



WALL MOUNT FAN

Part #	JSP24FAN/WM
Description	Wall Mount Fan
Blade Type	4 x 165mm Width Steel
Blade Diameter	600mm (24")
Motor	240V Single Speed

VENTILATORS

Suitable for air/fume extraction or blowing fresh air. Ideal ventilation for workshops and confined areas.

- 200mm to 600mm diameter ventilators available
- Large capacity motor creating a very high flow rate
- Specially designed axial propeller
- High static pressure

200mm VENTILATOR



TPV200SET

Part #	TPV200
Blade Diameter	200mm
Flow Rate	25m ³ /min
Motor	150w 240V
Speed	2900rpm
Weight	9.0kg

Part No.	Description
TPV200DUCT	5 Metre Expandable Ducting To Suit 200mm Ventilator
TPV200SET	Ventilator Set Includes 200mm Ventilator & Ducting

200mm STAINLESS STEEL VENTILATOR



- Stainless steel components to minimise corrosion

Part #	JPV200SS
Blade Diameter	200mm
Flow Rate	25m ³ /min
Motor	150w 240V
Speed	2900rpm
Weight	9.0kg

300mm VENTILATOR



TPV300SET

Part #	TPV300
Blade Diameter	300mm
Flow Rate	60m ³ /min
Motor	550w 240V
Speed	2900rpm
Weight	13.0kg

Part No.	Description
TPV300DUCT	5 Metre Expandable Ducting To Suit 300mm Ventilator
TPV300SET	Ventilator Set Includes 300mm Ventilator & Ducting

400mm VENTILATOR



TPV400SET

Part #	TPV400
Blade Diameter	400mm
Flow Rate	128m ³ /min
Motor	1500w 240V
Speed	2900rpm
Weight	35.0kg

Part No.	Description
TPV400DUCT	5 Metre Expandable Ducting To Suit 400mm Ventilator
TPV400SET	Ventilator Set Includes 400mm Ventilator & Ducting

500mm VENTILATOR

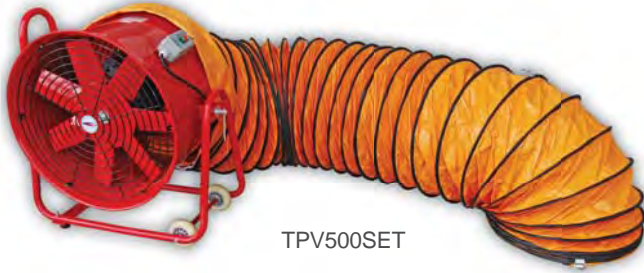

TPV500SET

Part #	TPV500
Blade Diameter	500mm
Flow Rate	138m ³ /min
Motor	1500w 240V
Speed	2900rpm
Weight	41.0kg

Part No.	Description
TPV500DUCT	5 Metre Expandable Ducting To Suit 500mm Ventilator
TPV500SET	Ventilator Set Includes 500mm Ventilator & Ducting

600mm VENTILATOR

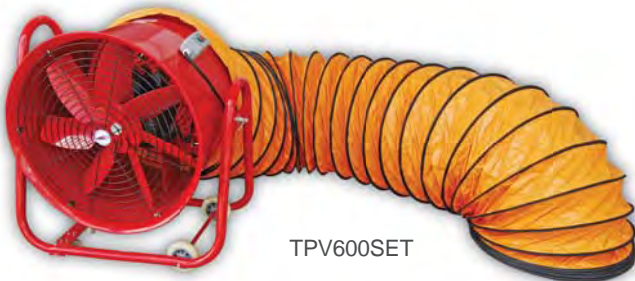

TPV600SET

Part #	TPV600
Blade Diameter	600mm
Flow Rate	290m ³ /min
Motor	2200w 240V
Speed	1450rpm
Weight	69.0kg

Part No.	Description
TPV600DUCT	5 Metre Expandable Ducting To Suit 600mm Ventilator
TPV600SET	Ventilator Set Includes 600mm Ventilator & Ducting

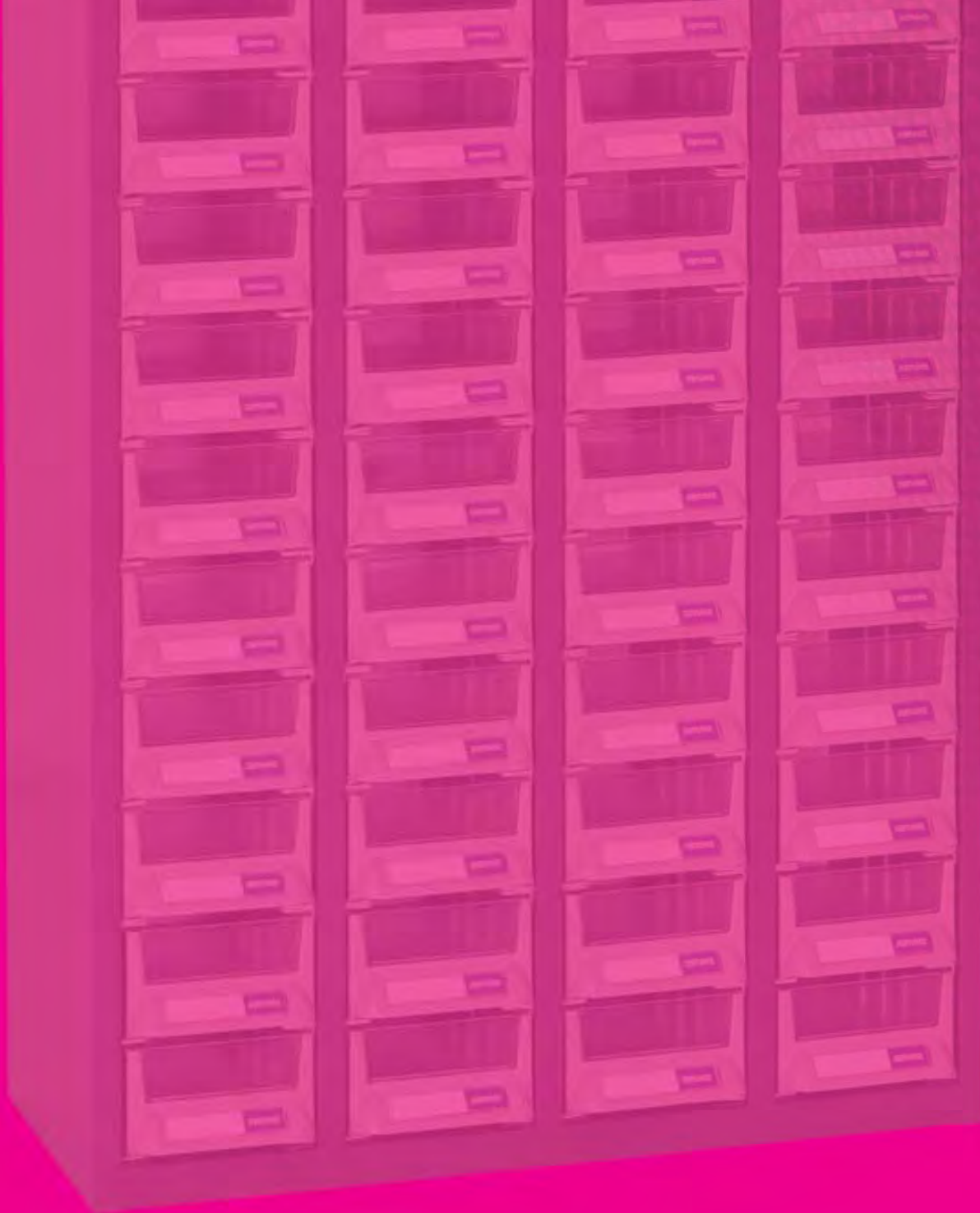

WORKSHOP STORAGE

Parts Cabinets	215
Parts Bins	219
Workshop Shelving	221
Tool Carts	223

PARTS CABINETS

- Highest quality & heavy duty, robust parts cabinets designed for industrial use
- Metal frame construction using 0.8mm galvanised steel
- Large range of sizes and styles
- Drawers come with dividers & contents description slip

A4 SERIES

230W x 325D x 37H MM

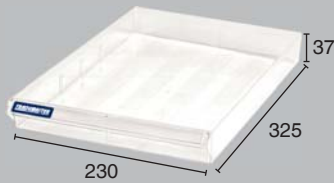

- Metal frame construction using 0.8mm galvanised steel
- Ideal for storing A4 documents
- Transparent drawers to easily identify contents inside
- Additional dividers available in packs of 10 (PB-A4DIVIDER)



PB-A4110P



PB-A4230P

Part No.	Drawers	Dimensions (mm)
PB-A4110P	10	285W x 340D x 483H
PB-A4230P	30	543W x 340D x 738H

A5 SERIES

163W x 289D x 69H MM

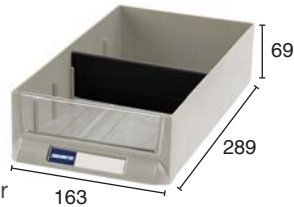

- Metal frame construction using 0.8mm galvanised steel
- Large capacity
- ABS high strength plastic drawer - oil, acid & impact resistant
- Transparent PS plastic window
- 10kg capacity per drawer
- Ideal for workshop use
- Slots for 5x dividers (6 divisions)
- 1x divider supplied per drawer
- Additional dividers available in packs of 10 (PB-A5DIVIDER)

Part No.	Drawers	Dimensions (mm)
PB-A5312	12	586W x 290D x 350H
PB-A5324	24	586W x 290D x 640H
PB-A5336	36	586W x 290D x 937H
PB-A5336D (With Doors)	36	586W x 340D x 970H



PB-A5312



PB-A5324



PB-A5336



PB-A5336D

A6 SERIES

150W x 248D x 83H MM

- Metal frame construction using 0.8mm galvanised steel
- ABS high strength plastic drawer - oil, acid & impact resistant
- Transparent PS plastic window
- 10kg capacity per drawer
- Ideal for workshop use
- Slots for 3x dividers (4 divisions)
- 1x divider supplied per drawer
- Additional dividers available in packs of 10 (PB-A6DIVIDER)



Part No.	Drawers	Dimensions (mm)
PB-A6309H	9	533W x 265D x 310H
PB-A6212H	12	362W x 265D x 571H
PB-A6330H	30	533W x 265D x 937H
PB-A6330HD (With Doors)	30	533W x 313D x 970H



PB-A6309H

PB-A6212H

PB-A6330H

PB-A6330HD

A7 SERIES

120W x 218D x 69H MM

- Metal frame construction using 0.8mm galvanised steel
- Smaller capacity drawers, great for storing a large range of small components
- ABS high strength plastic drawer - oil, acid & impact resistant
- Transparent PS plastic window
- 10kg capacity per drawer
- Slots for 3x dividers (4 divisions)
- 1x divider supplied per drawer
- Additional dividers available in packs of 10 (PB-A7DIVIDER)



Part No.	Drawers	Dimensions (mm)
PB-A7416	16	586W x 222D x 350H
PB-A7324	24	444W x 222D x 642H
PB-A7448	48	586W x 222D x 937H
PB-A7448D (With Doors)	48	586W x 270D x 970H



PB-A7416

PB-A7324

PB-A7448

PB-A7448D

A8 SERIES

90W x 218D x 70H MM

- Metal frame construction using 0.8mm galvanised steel
- Smaller capacity drawers, great for storing a large range of small components
- Full ABS high strength plastic drawer - oil, acid & impact resistant
- 10kg capacity per drawer
- Slots for 3x dividers (4 divisions)
- 1x divider supplied per drawer
- Additional dividers available in packs of 10 (PB-A8DIVIDER)



Part No.	Drawers	Dimensions (mm)
PB-A8416	16	466W x 222D x 350H
PB-A8432	32	466W x 222D x 642H
PB-A8560	60	586W x 222D x 937H



PB-A8416



PB-A8432



PB-A8560

HD SERIES

164W x 375D x 105H MM

- Metal frame construction using 0.8mm galvanised steel
- ABS high strength plastic drawer - oil, acid & impact resistant
- Transparent PS plastic window
- Slots for 7x dividers (8 divisions)
- 2x dividers supplied per drawer
- Additional dividers available in packs of 10 (PB-HDDIVIDER)

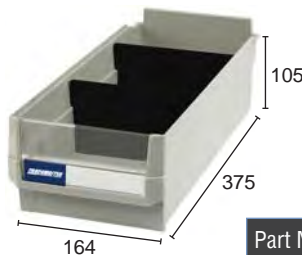

Part No.	Drawers	Dimensions (mm)
PB-HD309	9	550W x 400D x 440H
PB-HD515	15	880W x 400D x 440H
PB-HD318	18	550W x 400D x 880H

- ① High impact dividers for secure drawer organisation
- ② Anti-drop design for added safety
- ③ 25mm galvanised shelf for extra strength
- ④ 20kg capacity per drawer



PB-HD309



PB-HD515



PB-HD318

ST1 SERIES

90W x 218D x 55H MM

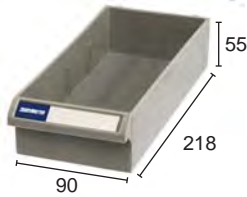

- Metal frame construction using 0.8mm galvanised steel
- Smaller capacity drawers, great for storing a large range of small components
- Full ABS high strength plastic drawer - oil, acid & impact resistant
- 10kg capacity per drawer
- Slots for 3x dividers (4 divisions)
- 1x divider supplied per drawer
- Additional dividers available in packs of 10 (PB-ST1DIVIDER)

Part No.	Description	Dimensions (mm)
PB-ST1575	75 Drawer	586W x 222D x 937H

ST2 SERIES

120W x 218D x 55H MM

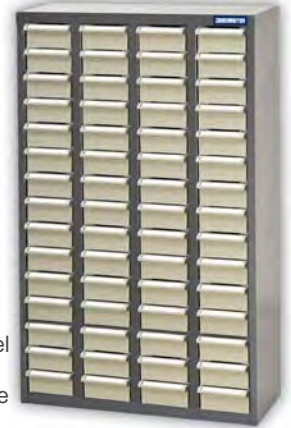
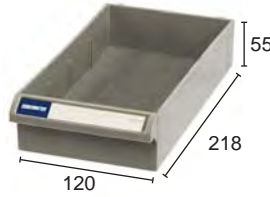

- Metal frame construction using 0.8mm galvanised steel
- Smaller capacity drawers, great for storing a large range of small components
- Full ABS high strength plastic drawer - oil, acid & impact resistant
- 10kg capacity per drawer
- Slots for 3x dividers (4 divisions)
- 1x divider supplied per drawer
- Additional dividers available in packs of 10 (PB-ST2DIVIDER)

Part No.	Description	Dimensions (mm)
PB-ST2460	60 Drawer	586W x 222D x 937H

MOBILE PARTS CABINET



- Metal frame construction using 0.8mm galvanised steel
- 100mm heavy duty castors - 2x swivel lockable, 2x fixed
- ABS high strength plastic drawer - oil, acid & impact resistant
- Transparent PS plastic window
- 20kg capacity per drawer
- Slots for 7x dividers (8 divisions)
- 2x dividers supplied per drawer
- Additional dividers available in packs of 10 (PB-HDDIVIDERS)
- Shipped ready to assemble

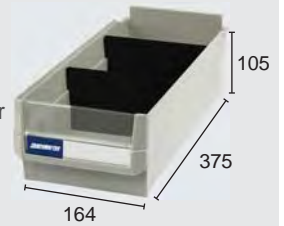

Part No.	Drawers	Dimensions (mm)
PB-NHD530	30	980W x 400D x 1010H

MOBILE BASE

For use with 2x PB-A7448 or 2x PB-A8560

- Load capacity 300kg
- 100mm heavy duty castors - 2x swivel lockable, 2x fixed



Part No.	Description	Dimensions (mm)
PB-W6045	Parts Cabinet Mobile Base	596W x 454D x 160H

LOCKABLE CABINET

Metal frame construction using 0.8mm galvanised steel

- Lockable doors
- 2 movable shelves



Part No.	Description	Dimensions (mm)
PB-THD2S	Lockable Cabinet	880W x 400D x 880H

PARTS BINS

HB SERIES



8x PB-HB1525Y

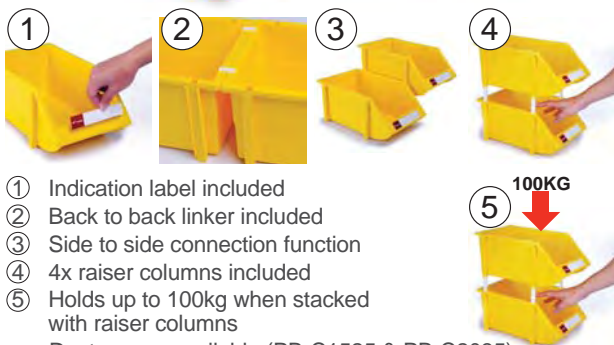

- ① Indication label included
 - ② Back to back linker included
 - ③ Side to side connection function
 - ④ 4x raiser columns included
 - ⑤ Holds up to 100kg when stacked with raiser columns
- Dust covers available (PB-C1525 & PB-C2035)



PB-HB1218B
PB-HB1525B
PB-HB2035B
PB-HB3045B

Part No.	Description	Dimensions (mm)
PB-HB1218B	Parts Bin - Blue	121W x 180D x 84H
PB-HB1525B	Parts Bin - Blue	150W x 265D x 121H
PB-HB2035B	Parts Bin - Blue	208W x 353D x 155H
PB-HB3045B	Parts Bin - Blue	300W x 480D x 178H
PB-HB1218Y	Parts Bin - Yellow	121W x 180D x 84H
PB-HB1525Y	Parts Bin - Yellow	150W x 265D x 121H
PB-HB2035Y	Parts Bin - Yellow	208W x 353D x 155H
PB-HB3045Y	Parts Bin - Yellow	300W x 480D x 178H
PB-HB1218R	Parts Bin - Red	121W x 180D x 84H
PB-HB1525R	Parts Bin - Red	150W x 265D x 121H
PB-HB2035R	Parts Bin - Red	208W x 353D x 155H
PB-HB3045R	Parts Bin - Red	300W x 480D x 178H

PARTS BIN MOBILE STAND PRE-CONFIGURED

Features:

- Double sided, heavy duty design
- 4x Swivel castors, 2 locking
- Can be expanded with more small & medium sized parts bins
- Optional punched panel available for storage of other items on peg hooks (PB-HP068630)

Includes:

- 1x Mobile Stand (PB-MS630)
- 20x Small Parts Bins (PB-HB1218)
- 20x Medium Parts Bins (PB-HB1525) (colours may vary)
- 9x Parts Bin Hang Panels (PB-MSHP06-5)



PARTS BIN MOBILE STAND CUSTOM ASSEMBLY

The Parts Bin Mobile Stand can be customised to suit. Each unit can take parts bins and punch panels of up to a total height of 48 slots, per side.



1x row of Small Parts Bins (PB-HB1218) require a height of 4 slots



1x row of Medium Parts Bins (PB-HB1525) require a height of 5 slots



1x Punched Panel (PB-HP068630) require a height of 16 slots

- Each row of Parts Bins requires
- 1x Hang Panel (PB-MSHP06-5)



PB-MS630

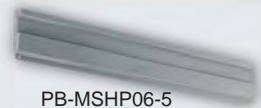

PB-MSHP06-5



PB-HP068630

Part No.	Description	Dimensions (mm)
PB-MS201215	PB Parts Bin Display Unit	690W x 560D x 1460H

Part No.	Description	Dimensions (mm)
PB-MS630	Mobile Stand	690W x 560D x 1460H
PB-MSHP06-5	Mobile Stand PB Parts Bin Hang Panel	630W x 91H (4 Slots)
PB-HP068630	Mobile Stand Punched Panel	630W x 400H (16 Slots)

LOUVRE PANEL TO SUIT HB SERIES PARTS BINS

- Metal construction



PB-LP455610 shown with PB-HB1525Y parts bins (not included)

Part No.	Description	Dimensions (mm)
PB-LP455455	Louvre Panel Small	455W x 455H
PB-LP455610	Louvre Panel Medium	455W x 610H
PB-LP455914	Louvre Panel Large	455W x 914H

ROTATING FLIP OUT BINS RFO SERIES

- Revolving tower for easy access



PB-RFO636

PB-RFO848

PB-RFO690

PB-RFO8144

Part No.	Description	Dimensions (mm)
PB-RFO636	Rotating Flip Out Bin 36 Drawer PB-FO306 x 6 sets	449W x 518.3D x 530H
PB-RFO848	Rotating Flip Out Bin 48 Drawer PB-FO308 x 6 sets	449W x 518.3D x 430H
PB-RFO690	Rotating Flip Out Bin 90 Drawer PB-FO306 x 15 sets	449W x 518.3D x 1280H
PB-RFO8144	Rotating Flip Out Bin 144 Drawer PB-FO308 x 18 sets	449W x 518.3D x 1230H

FLIP OUT BINS FO SERIES



- ① Joining 2 or more units together both vertically and horizontally is simple due to the patented dove tail joint. Different sized Flip Out Bins can also be joined together.
- ② Bins are completely removable for easy access and refilling
- ③ Bins open smoothly to a 40° angle
- ④ Bins securely clip closed to ensure they do not fall open



PB-FO308

PB-FO605



PB-FO306

PB-FO604

Part No.	Description	Dimensions (mm)
PB-FO308	Flip Out Bin 8 Drawer	303W x 87D x 203H
PB-FO306	Flip Out Bin 6 Drawer	303W x 106D x 253H
PB-FO605	Flip Out Bin 5 Drawer	603W x 123D x 153H
PB-FO604	Flip Out Bin 4 Drawer	603W x 167D x 203H

FLIP OUT BIN MOBILE STAND PRE-CONFIGURED

Storage for small components such as screws, bolts, tools, etc. Great for keeping your work area organised.

Features

- Double sided
- 4x Swivel castors, 2 locking
- Can be expanded
- Optional punched panel available for storage of other items on peg hooks (PB-HP068630)

Includes

- 1x Mobile Stand (PB-MS630)
- 2x 8 Drawer Bin (PB-FO308)
- 2x 6 Drawer Bin (PB-FO306)
- 2x 5 Drawer Bin (PB-FO605)
- 2x 4 Drawer Bin (PB-FO604)
- 6x Flip Out Bin Hang Panels (PB-MS06)



Part No.	Description	Dimensions (mm)
PB-MSFO4568	Flip Out Bin Display Unit	690W x 560D x 1460H

FLIP OUT BIN MOBILE STAND CUSTOM ASSEMBLY

The Flip Out Bin Mobile Stand can be customised to suit. Each unit can take flip bins and punch panels of up to a total height of 48 slots, per side.



1x row of Flip Out Bin 8 Drawer (PB-FO308) require a height of 8 slots

1x row of Flip Out Bin 6 Drawer (PB-FO306) require a height of 10 slots

1x row of Flip Out Bin 5 Drawer (PB-FO605) require a height of 6 slots
 1x row of Flip Out Bin 4 Drawer (PB-FO604) require a height of 8 slots
 1x Punched Panel (PB-HP068630) require a height of 16 slots
 Each row of Flip Out Bins requires 1x Hang Panel (PB-MS06)



PB-MS630

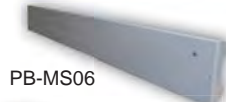

PB-MS06



PB-HP068630

Part No.	Description	Dimensions (mm)
PB-MS630	Mobile Stand	690W x 560D x 1460H
PB-MS06	Mobile Stand FO Parts Bin Hang Panel	630W x 76H (4 Slots)
PB-HP068630	Mobile Stand Punch Panel	630W x 400H (16 Slots)

WORKSHOP SHELVING

BOLTLESS RIVET SHELVING



Sturdy workshop shelving available in a range of sizes. Boltless construction makes assembly and shelf reorganizing quick and efficient.



Features

- 5 laminate timber shelves
- Boltless steel construction
- Corrosive resistant hammertone finish
- Comes complete in 1 box

Part No.	Size	Shelf Load Cap.
PB-RS09300	900mm W x 300mm D x 1800mm H	250kg each
PB-RS09450	900mm W x 450mm D x 1800mm H	250kg each
PB-RS12450	1200mm W x 450mm D x 1800mm H	200kg each
PB-RS12600	1200mm W x 600mm D x 1800mm H	200kg each

INDUSTRIAL WORKSHOP SHELVING

Robust industrial workshop shelving. Boltless construction makes assembly and shelf reorganising quick and efficient.

Features

- 4 reinforced wire mesh shelves
- Heavy steel construction
- Corrosion resistant hammertone finish
- Diagonal support arms for extra strength
- Comes complete in 1 box



Specifications

- Shelf loading capacity: 400kg each



Part No.	Size
PB-RS19600	1955mm W x 600mm D x 1800mm H

EXTRA HEAVY DUTY WORKSHOP SHELVING

- Workshop shelving available as a complete pre-configured package including 4 shelves and 2 uprights. Available in 3 different widths 1.4m, 2.0m & 2.2m.
- Individual components including cross beams, uprights, steel shelves & wire shelves also available
- Shelf loading capacity 800kgs
- Uprights shipped pre-assembled in box

Carton quantities:
 - 2 x Uprights per box
 - 4 x Beams per box
 - 4 x Shelves per box



Wire shelving also available

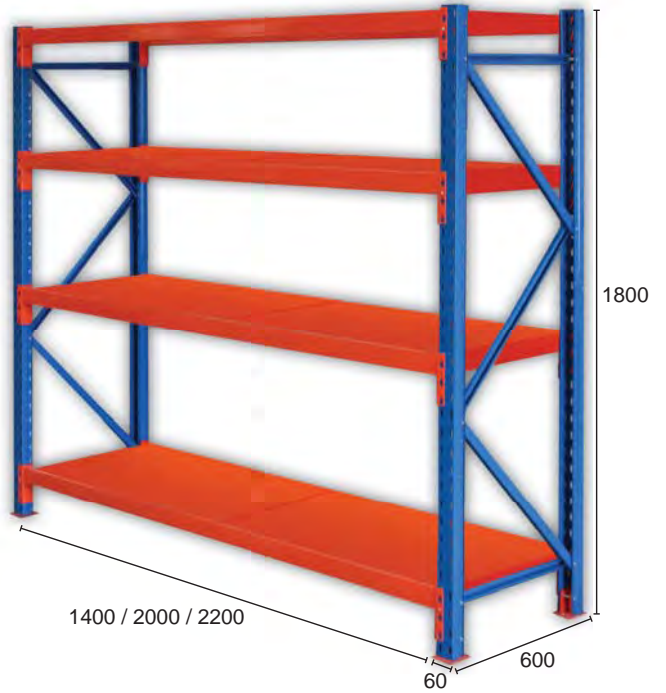

1400MM WIDTH SHELVING

Part No.	Description
Pre Configured Packages	
PB-WSP1400X4	1400mm Width Shelving Package
PB-WSP1400X4W	1400mm Width Shelving Package With Wire Shelving
Individual Components	
PB-WSC010	Upright 1800mm Height Including Feet
PB-WSC1410	Cross Beam 1400mm Width (2 Required)
PB-WSC1420	Steel Shelf Including Support Bracket 690mm Width (2 Required)
PB-WSC1430	Wire Shelf 1380mm Width (1 Required)

2000MM WIDTH SHELVING

Part No.	Description
Pre Configured Packages	
PB-WSP2000X4	2000mm Width Shelving Package
PB-WSP2000X4W	2000mm Width Shelving Package With Wire Shelving
Individual Components	
PB-WSC010	Upright 1800mm Height Including Feet
PB-WSC2010	Cross Beam 2000mm Width (2 Required)
PB-WSC2020	Steel Shelf Including Support Bracket 990mm Width (2 Required)
PB-WSC2030	Wire Shelf 990mm Width (2 Required)

2200MM WIDTH SHELVING

Part No.	Description
Pre Configured Packages	
PB-WSP2200X4	2200mm Width Shelving Package
PB-WSP2200X4W	2200mm Width Shelving Package With Wire Shelving
Individual Components	
PB-WSC010	Upright 1800mm Height Including Feet
PB-WSC2210	Cross Beam 2200mm Width (2 Required)
PB-WSC2220	Steel Shelf Including Support Bracket 1090mm Width (2 Required)
PB-WSC2230	Wire Shelf 1090mm Width (2 Required)

TOOL CARTS

PROFESSIONAL CNC TOOL CARTS

- 1.63mm metal frame construction for strength & durability
- Each cart holds 28x ABS BT-40 universal tool bit holders
- The tool bit holder shelves can be placed at different heights and angles to suit your needs
- Work shelf positioned on side of cart
- PB-NTW4B2D features 2x lockable drawers
- Heavy duty 4" castor wheels
- BT-30, BT-50 & HSK-63 holders available on request



PB-NTW4B



PB-NTW4B2D
Comes with lockable drawers

Part No.	Description	Dimensions (mm)
PB-NTW4B	4 Rack Tool Cart	1002W x 650D x 810H
PB-NTW4B2D	4 Rack, 2 Drawer Tool Cart	1002W x 650D x 810H

ULTRA HEAVY DUTY TOOL CARTS



PB-CT5086

PB-CTH5086

- 1.2mm metal frame construction
- 200kg total load capacity
- Adjustable height of each layer
- Each shelf & drawer includes a 3mm anti-slide EVA cushion

PB-CTCH5086 drawer dimensions:

- 2 Drawers 40 x 270 x 570mm
- 1 Drawer 65 x 270 x 570mm

- ① Curved edge design
- ② Peg boards allowing quick access to frequently used tools
- ③ Lockable drawer provides extra security (PB-CTCH5086)
- ④ 100mm heavy duty castors - 2x swivel lockable, 2x fixed

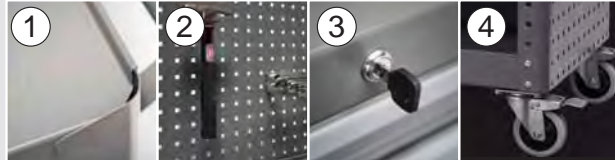

Part No.	Description	Dimensions (mm)
PB-CT5086	Tool Cart	873W x 500D x 880H
PB-CTH5086	Tool Cart With Side Panels	873W x 500D x 880H
PB-CTCH5086	Tool Cart With Lock Drawers	873W x 500D x 880H

HANG PANELS FOR USE WITH ULTRA HEAVY DUTY TOOL CARTS

- Can be used to hold the following FO series bins per hang panel : 2x PB-FO604 or 3x PB-FO605 or 4x PB-FO304 or 4x PB-FO308

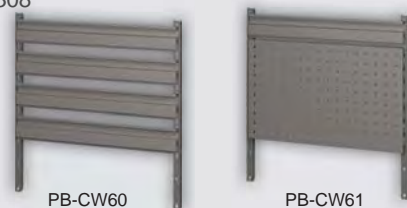

PB-CW60

PB-CW61

Part No.	Description	Dimensions (mm)
PB-CW60	4x Hang Panels For Use With Ultra Heavy Duty Tool Carts	674W x 25D x 632H
PB-CW61	1x Hang Panel & Peg Board For Use With Ultra Heavy Duty Tool Carts	674W x 25D x 632H

Magnetic Base Drilling Machines

Cutting Tools

Clamps

Engineer's Tools

Sharpening Machines

Metal Cutting Saws

Drilling Machines

Bevelling Machines & Welding Carriages

Punches & Shears

Grinding Machines

Fans & Ventilators

Workshop Storage

M7 Airtools

NPK Airtools

Pneumatic Products



M7 AIR TOOLS

Impact Wrenches	226	Drills	250
Angle Drive Impact Ratchets	232	Screwdrivers	252
Ratchet Wrenches	233	Punch & Flange Tool	253
Rivet Nut Tool	235	Polishers	254
Tappers	235	Sanders	255
Hydraulic Riveters	236	Belt Sanders	258
Riveter Adaptors	238	Flux Chipper	258
Rivet Nut Adaptors	238	Needle Scalers	259
Sheet Metal Cutters	239	Air Hammers	260
Nailers	240	Grease Guns	262
Staplers	241	Automotive Tools	262
Angle Grinders	242	Air Brush Set	267
Cut Off Tools	244	Air Tool Accessories	267
Die Grinders	246	Impact Sockets	270
Engraving Pen	248	Impact Socket Accessories	288
Buffer	249	Impact Socket Sets	290

**SUPPORT
VALUE
EXPERTISE**



PNEUMATIC TOOLS



WWW.M7AIRTOOLS.COM

1/4" DRIVE AIR IMPACT WRENCHES

M7-NC0208 1/4" DRIVE AIR IMPACT WRENCH SET

Rocking dog clutch
Kit contains :

- 1pc 1/4" Air Impact Wrench (M7-NC2710)
- 5pcs Socket : 8, 9, 10, 11, 12mm
- 1pc 1/4" drive universal joint
- 1pc 1/4" 44mm extension bar
- 1pc plug (adapter)



M7-NC2210 1/4" DRIVE MINI AIR IMPACT WRENCH

Max torque
at 5 seconds : 50 ft-lb
Net weight : 0.65kg

- Twin dog type



Part No.	Square Drive Bolt Capacity		Torque Range		Max Torque at 5 seconds		Free Speed	Air Requirement			Overall Length	Net Weight	Sound Pressure	Vibration Level
	Inch	mm	ft-lb	Nm	ft-lb	Nm		RPM	CFM	PSI				
M7-NC0208	1/4"	M8	7.4-29.5	10-40	29	40	11000	5.3	90	1/4"	136	0.8	91	3.4
M7-NC2210	1/4"	M5	4-45	6-61	50	67.8	11000	1.8	90	1/4"	166	0.65	77.0	1.8

3/8" DRIVE AIR IMPACT WRENCHES

M7-NC3810 3/8" DRIVE AIR IMPACT WRENCH

Max torque
at 5 seconds : 75 ft-lb
Net weight : 0.5kg

- Only 139mm length, great mini one handed operation
- Butterfly throttle
- Twin dog hammer type



M7-NC3410 3/8" DRIVE AIR IMPACT WRENCH

Max torque
at 5 seconds : 75 ft-lb
Net weight : 0.8kg

- Butterfly throttle
- Rocking dog type



M7-NC3111 3/8" DRIVE AIR IMPACT WRENCH

Max torque
at 5 seconds : 160 ft-lb
Net weight : 1.6kg

- Pin clutch type



M7-NC3610Q 3/8" DRIVE AIR IMPACT WRENCH

Max torque
at 5 seconds : 350 ft-lb
Net weight : 1.5kg

- Jumbo hammer type
- Low noise level
- Compact size 115.5mm length
- Very low weight



**MIGHTY SMALL
MIGHTY QUIET
MIGHTY POWERFUL
Q-SERIES**

Part No.	Square Drive Bolt Capacity		Torque Range		Max Torque at 5 seconds		Free Speed	Air Requirement			Overall Length	Net Weight	Sound Pressure	Vibration Level
	Inch	Inch (mm)	ft-lb	Nm	ft-lb	Nm		RPM	CFM	PSI				
M7-NC3810	3/8"	3/8" (10)	5-50	7-68	75	102	11000	2.3	90	1/4"	139	0.5	91.0	3.6
M7-NC3410	3/8"	3/8" (10)	5-50	7-68	75	102	10000	2.5	90	1/4"	159	0.8	92.1	3.6
M7-NC3111	3/8"	1/2" (13)	70-130	95-176	160	216	9000	4.0	90	1/4"	163	1.6	93.3	4.1
M7-NC3610Q	3/8"	1/2" (13)	100-300	136-407	350	474	8000	4.4	90	1/4"	115.5	1.5	85.0	2.8

**M7-NC3812**
3/8" DRIVE AIR STRAIGHT
IMPACT WRENCH

Free speed : 8000 RPM
 Max torque at 5 seconds : 180 ft-lb
 Net weight : 1.06kg

- Twin dog type

**M7-NC3911**
3/8" DRIVE 90° AIR IMPACT WRENCH

Free speed : 7000 RPM
 Max torque at 5 seconds : 100 ft-lb
 Net weight : 1.60kg

- Twin dog type

**M7-NC3920**
3/8" DRIVE AIR STRAIGHT
IMPACT WRENCH

Free speed : 700 RPM
 Max torque at 5 seconds : 50 ft-lb
 Net weight : 0.6kg

- Unicorn hammer type



Part No.	Square Drive	Bolt Capacity	Torque Range		Max Torque at 5 seconds		Free Speed	Air Requirement			Overall Length	Net Weight	Sound Pressure	Vibration Level
	Inch		Inch (mm)	ft-lb	Nm	ft-lb		Nm	RPM	CFM				
M7-NC3812	3/8"	1/2" (13mm)	66-120	89-162	180	244	8000	10	90	1/4"	190	1.06	97.0	5.1
M7-NC3911	3/8"	3/8" (10mm)	5-44	7-60	100	135	7000	7	90	1/4"	240	1.60	92.0	5.1
M7-NC3920	3/8"	3/8" (10mm)	5-37	7-50	50	68	700	3.1	90	1/4"	164	0.6	88.0	1.85



1/2" DRIVE AIR IMPACT WRENCHES

M7-NC4630Q 1/2" DRIVE AIR SUPER MINI IMPACT WRENCH

Max torque at 5 seconds : 450 ft-lb

- 68% lighter compared with ordinary models - Only 1.5kg!
- 60% shorter compared with ordinary models - Only 97mm long!
- Jumbo hammer type
- Best in class performance for a tool of just 97mm length and 1.5kg weight
- The minimum size of this tool will allow greater access to tight and limited spaces
- Small but with great power, reach 450 ft-lb in just 5 seconds
- Easy to remove vehicle's crankshaft pulley without removing anything else
- Low noise sound level of 85dBA



MIGHTY SMALL
MIGHTY QUIET
MIGHTY POWERFUL
Q-SERIES

M7-NC4258 STANDARD ANVIL - PICTURED M7-NC4268 2" ANVIL 1/2" DRIVE AIR IMPACT WRENCH

Max torque
at 5 seconds : 400 ft-lb
Net weight : 2.5kg

- Twin hammer type
- Common applications are automotive services and body shops
- Reliable and efficient air impact wrench



M7-NC4610Q 1/2" DRIVE AIR MINI IMPACT WRENCH

Max torque
at 5 seconds : 400 ft-lb
Net weight : 1.6kg

- 115.5mm length
- Jumbo hammer type

MIGHTY SMALL
MIGHTY QUIET
MIGHTY POWERFUL
Q-SERIES



M7-NC4232Q 1/2" DRIVE AIR IMPACT WRENCH

Max torque at 5 seconds : 550 ft-lb
Net weight : 1.35kg

- Advanced composite mini air impact wrench, ideal for narrow spaces.
- Twin-hammer type

MIGHTY SMALL
MIGHTY QUIET
MIGHTY POWERFUL
Q-SERIES



M7-NC4230Q 1/2" DRIVE AIR IMPACT WRENCH

Max torque at
5 seconds : 700 ft-lb
Net weight : 2.5kg

- Twin hammer type

MIGHTY SMALL
MIGHTY QUIET
MIGHTY POWERFUL
Q-SERIES



Part No.	Square Drive	Bolt Capacity	Torque Range		Max Torque at 5 seconds		Free Speed	Air Requirement			Overall Length	Net Weight	Sound Pressure	Vibration Level
	Inch		Inch (mm)	ft-lb	Nm	ft-lb		Nm	RPM	CFM				
M7-NC4630Q	1/2"	5/8" (16)	200-350	271-475	450	610	9000	4.4	90	1/4"	97	1.5	85.0	2.8
M7-NC4258	1/2"	5/8" (16)	150-300	203-407	400	542	7000	4.2	90	1/4"	185	2.5	93.2	4.4
M7-NC4268	1/2"	5/8" (16)	150-300	203-407	400	542	7000	4.2	90	1/4"	235	2.7	93.2	4.4
M7-NC4610Q	1/2"	5/8" (16)	200-350	271-475	400	678	9000	4.4	90	1/4"	115.5	1.6	85.0	2.8
M7-NC4232Q	1/2"	5/8" (16)	100-400	136-542	550	746	10000	4.0	90	1/4"	122	1.35	83.0	3.7
M7-NC4230Q	1/2"	3/4" (19)	180-500	244-678	700	949	7500	4.5	90	1/4"	164	2.5	85.0	4.5

Magnetic Base Drilling Machines

Cutting Tools

Clamps

Engineer's Tools

Sharpening Machines

Metal Cutting Saws

Drilling Machines

Bevelling Machines & Welding Carriages

Punches & Shears

Grinding Machines

Fans & Ventilators

Workshop Storage

M7 Airtools

NPK Airtools

Pneumatic Products





1/2" DRIVE AIR IMPACT WRENCHES

M7-NC0425 1/2" DRIVE AIR IMPACT WRENCH KIT

Max torque at 5 seconds : 400 ft-lb

- Twin hammer type
- Kit contents:
 - 1/2" Drive impact wrench (M7-NC4258)
 - 10 pcs 1/2" DR impact sockets: 10, 11, 12, 13, 14, 17, 19, 22, 24, 27mm
 - 1pc 125mm extension
 - 1pc 4mm allen key
 - 1pc mini oiler



M7-NC4620QN 1/2" DRIVE WHEEL NUT IMPACT WRENCH KIT

Max torque at 5 seconds : 450 ft-lb
Anvil length : 2"

- Jumbo hammer type
- Includes :
 - 1x impact wrench (M7-NC4610Q)
 - 1x 17 / 19mm reversible impact socket
 - 1x 21 / 22mm reversible impact socket



M7-NC4216 STANDARD ANVIL - PICTURED M7-NC4226 2" ANVIL 1/2" DRIVE AIR IMPACT WRENCH

Max torque at 5 seconds : 650 ft-lb
Net weight : 2.0kg

- Twin hammer type
- High quality composite body
- Common applications are automotive services and body shops



M7-NC4233 1/2" DRIVE AIR IMPACT WRENCH

Max torque at 5 seconds : 850 ft-lb
Net weight : 2.1kg

- Composite Body
- Twin hammer type
- Efficient & reliable torque output during operation

**MIGHTY SMALL
MIGHTY QUIET
MIGHTY POWERFUL
Q-SERIES**



Part No.	Square Drive	Bolt Capacity	Torque Range		Max Torque at 5 seconds		Free Speed	Air Requirement			Overall Length	Net Weight	Sound Pressure	Vibration Level
	Inch	Inch (mm)	ft-lb	Nm	ft-lb	Nm		RPM	CFM	PSI				
M7-NC4216	1/2"	5/8" (16)	180-400	244-542	650	881	9000	4.2	90	1/4"	195	2.0	93.9	4.5
M7-NC4226	1/2"	5/8" (16)	180-400	244-542	650	881	9000	4.2	90	1/4"	225	2.2	93.9	4.5
M7-NC4233	1/2"	3/4" (19)	200-500	271-678	850	1152	9000	4.6	90	1/4"	190	2.1	85.0	4.4

Part No.	Description
M7-NC0425	Impact Wrench Kit, Pistol Style, 15 Piece Kit, 1/2" DR, 400 FT-LB, Blow Mould Case
M7-NC4620QN	Impact Wheel Wrench Kit, Q-Series, Pistol Style, 1/2" DR, 450 ft-lb, 2" Anvil, With 17/19 & 21/22 Sockets

CLUTCH REFERENCE GUIDE



Magnetic Base Drilling Machines
Cutting Tools
Clamps
Engineer's Tools
Sharpening Machines
Metal Cutting Saws
Drilling Machines
Bevelling Machines & Welding Carriages
Punches & Shears
Grinding Machines
Fans & Ventilators
Workshop Storage
M7 Airtools
NPK Airtools
Pneumatic Products



M7-NC4255Q-2
1/2" DRIVE AIR
IMPACT WRENCH

Free speed : 7000 RPM
Max torque at 5 seconds : 1200 ft-lb
Net weight : 1.8kg

- Twin hammer type
- 2" extended anvil
- The front housing & back head cover made by magnesium alloy
- Durable composite material



M7-NC4266Q
1/2" DRIVE AIR
IMPACT WRENCH

Free speed : 9000 RPM
Max torque at 5 seconds : 1100 ft-lb
Net weight : 1.9kg

- Twin hammer type
- 2" extended anvil



M7-NC4811
1/2" DRIVE AIR STRAIGHT
IMPACT WRENCH

Free speed : 5500 RPM
Max torque at 5 seconds : 210 ft-lb
Net weight : 1.7kg

- Twin dog type



M7-NC4255Q-KIT
1/2" DRIVE AIR
IMPACT WRENCH KIT

Max torque at 5 seconds : 1200 ft-lb
Net weight : 1.7kg

- Magnesium alloy & composite material construction
- Extremely powerful & very lightweight
- Twin hammer type



M7-NC4650
1/2" DRIVE AIR
IMPACT WRENCH

Free speed : 9000 RPM
Max torque at 5 seconds : 650 ft-lb
Net weight : 1.4kg

- Compact length, only 104mm



Includes :

- M7-NC4255Q Impact wrench
- 13, 17, 19, 21, 22, 24, 27mm impact sockets
- 125mm Extension bar, locking ball type
- Mini lubricator

Part No.	Square Drive	Bolt Capacity	Torque Range		Max Torque at 5 seconds		Free Speed	Air Requirement			Overall Length	Net Weight	Sound Pressure	Vibration Level
	Inch		Inch (mm)	ft-lb	Nm	ft-lb		Nm	RPM	CFM				
M7-NC4255Q-2	1/2"	1" (25mm)	200-800	271-1085	1200	1627	8500	4.8	90	1/4"	230.5	1.8	85.0	4.7
M7-NC4266Q	1/2"	1" (25mm)	200-900	271-1220	1100	1491	9000	5.1	90	1/4"	191	1.9	85.0	2.8
M7-NC4811	1/2"	9/16" (M14)	118-140	160-189	210	285	5500	8.5	90	1/4"	260	1.7	85.0	5.3
M7-NC4650	1/2"	5/8" (16mm)	180-400	244-542	650	900	9000	4.69	90	1/4"	104	1.4	95.0	2.4
Part No.	Description													
M7-NC4255Q-KIT	1/2" Drive Impact Wrench Kit, 10 Piece													

Magnetic Base Drilling Machines

Cutting Tools

Clamps

Engineer's Tools

Sharpening Machines

Metal Cutting Saws

Drilling Machines

Bevelling Machines & Welding Carriages

Punches & Shears

Grinding Machines

Fans & Ventilators

Workshop Storage

M7 Airtools

NPK Airtools

Pneumatic Products





Magnetic Base Drilling Machines

Cutting Tools

Clamps

Engineer's Tools

Sharpening Machines

Metal Cutting Saws

Drilling Machines

Bevelling Machines & Welding Carriages

Punches & Shears

Grinding Machines

Fans & Ventilators

Workshop Storage

M7 Airtools

NPK Airtools

Pneumatic Products

M7-NC4255QH 1/2" DRIVE AIR IMPACT WRENCH

Max torque at 5 seconds : 1200 ft-lb
Net weight : 1.7kg

- Magnesium alloy & composite material construction
- Extremely powerful & very lightweight
- Twin hammer type
- Easy grease anvil

Q-SERIES

- SUPER LIGHTWEIGHT
- SUPER POWERFUL
- EXCEPTIONAL VALUE FOR MONEY



M7-NC4236Q 1/2" DRIVE AIR IMPACT WRENCH

Max torque at 5 seconds : 1000 ft-lb
Net weight : 2.6kg

- Twin hammer type
- High torque
- Exceptionally quiet

MIGHTY SMALL
MIGHTY QUIET
MIGHTY POWERFUL
Q-SERIES



M7-NC4256Q STANDARD ANVIL - PICTURED M7-NC4256Q-2 2" ANVIL 1/2" DRIVE AIR IMPACT WRENCH

Max torque at 5 seconds : 1100 ft-lb

- Lightweight
- Balanced weighted body
- Extra heavy duty construction
- Twin hammer type

MIGHTY SMALL
MIGHTY QUIET
MIGHTY POWERFUL
Q-SERIES



Part No.	Square Drive	Bolt Capacity	Torque Range		Max Torque at 5 seconds		Air Requirement			Overall Length	Net Weight	Sound Pressure	Vibration Level	
	Inch	Inch (mm)	ft-lb	Nm	ft-lb	Nm	RPM	CFM	PSI					Inlet
M7-NC4255QH	1/2"	1" (25)	200-800	271-1085	1200	1627	8500	4.8	90	1/4"	179	1.7	85.0	4.7
M7-NC4236Q	1/2"	1" (25)	200-700	271-949	1000	1356	7500	5.5	90	1/4"	171	2.62	83.0	4.5
M7-NC4256Q	1/2"	1" (25)	200-900	271-1220	1100	1491	9000	5.1	90	1/4"	141	1.8	85.0	2.8
M7-NC4256Q-2	1/2"	1" (25)	200-900	271-1220	1100	1491	9000	5.1	90	1/4"	191	1.9	85.0	2.8

3/4" DRIVE AIR IMPACT WRENCHES

M7-NC6210Q 3/4" DRIVE AIR IMPACT WRENCH

Max torque at 5 seconds : 700 ft-lb
Net weight : 2.55kg

- Twin hammer type
- Extremely light weight, 50% compared to ordinary models

MIGHTY SMALL
MIGHTY QUIET
MIGHTY POWERFUL
Q-SERIES



M7-NC6215 STANDARD ANVIL - PICTURED M7-NC6225 6" ANVIL 3/4" DRIVE AIR IMPACT WRENCH

Max torque at 5 seconds : 900 ft-lb
Net weight : 4.5kg

- New twin hammer type



Part No.	Square Drive	Bolt Capacity	Torque Range		Max Torque at 5 seconds		Air Requirement			Overall Length	Net Weight	Sound Pressure	Vibration Level	
	Inch	Inch (mm)	ft-lb	Nm	ft-lb	Nm	RPM	CFM	PSI					Inlet
M7-NC6210Q	3/4"	3/4" (19)	180-600	244-810	700	949	6500	4.5	90	1/4"	170	2.55	85.0	4.5
M7-NC6215	3/4"	1" (25)	180-600	244-810	900	1220	6500	7	90	1/4"	234	4.5	91.5	10.8
M7-NC6225	3/4"	1" (25)	180-600	244-810	900	1220	6500	7	90	1/4"	350	4.9	91.5	10.8





M7-NC6255Q STANDARD ANVIL - PICTURED
M7-NC6255Q-6 6" ANVIL
3/4" DRIVE AIR IMPACT WRENCH

Max torque at
 5 seconds : 1400 ft-lb
 • Twin hammer type

MIGHTY SMALL
 MIGHTY QUIET
 MIGHTY POWERFUL
Q-SERIES



M7-NC6226
3/4" DRIVE AIR IMPACT WRENCH

Max torque at
 5 seconds : 1200 ft-lb
 Net weight : 4.5kg
 • 6" extended anvil
 • Composite material



M7-NC6255Q-KIT
3/4" DRIVE AIR IMPACT WRENCH KIT

Max torque at 5 seconds : 1400 ft-lb
 • Twin hammer type



M7-NC6266
3/4" DRIVE AIR IMPACT WRENCH

Max torque at
 5 seconds : 1500 ft-lb
 Net weight : 3kg
 • Spring mounted rotor blades for extra durability
 • Magnesium housing



Includes :

- M7-NC6255Q Impact wrench
- 24, 27, 30, 32, 33, 34, 36mm impact sockets
- 175mm Extension bar, locking ball type
- Mini lubricator

Part No.	Square Drive	Bolt Capacity	Torque Range		Max Torque at 5 seconds		Free Speed			Air Requirement			Overall Length	Net Weight	Sound Pressure	Vibration Level
	Inch		Inch (mm)	ft-lb	Nm	ft-lb	Nm	RPM	CFM	PSI	Inlet	mm				
M7-NC6255Q	3/4"	1" (25mm)	200-1100	271-1491	1400	1890	8500	4.8	90	1/4"	198	1.9	85.0	4.7		
M7-NC6255Q-6	3/4"	1" (25mm)	200-1100	271-1491	1400	1890	8500	4.8	90	1/4"	350	2.38	85.0	4.7		
M7-NC6226	3/4"	1-1/16" (27mm)	200-1000	271-1356	1200	1627	6000	6.0	90	3/8"	350	4.5	91.2	5.0		
M7-NC6266	3/4"	1-1/4" (30mm)	200-1300	271-1760	1500	2034	6000	5.9	90	1/4"	205	3.0	88.0	5.9		
Part No.	Description															
M7-NC6255Q-KIT	3/4" Drive Impact Wrench Kit, 10 Piece															

Magnetic Base Drilling Machines

Cutting Tools

Clamps

Engineer's Tools

Sharpening Machines

Metal Cutting Saws

Drilling Machines

Bevelling Machines & Welding Carriages

Punches & Shears

Grinding Machines

Fans & Ventilators

Workshop Storage

M7 Airtools

NPK Airtools

Pneumatic Products





M7-NC6236Q
3/4" DRIVE AIR
IMPACT WRENCH

Max torque
at 5 seconds : 1200 ft-lb
Net weight : 2.68Kg

- Extra heavy duty quality & durability
- Extremely light weight, 50% compared to ordinary models
- Twin hammer type

**MIGHTY SMALL
MIGHTY QUIET
MIGHTY POWERFUL
Q-SERIES**



M7-NC6217
3/4" DRIVE AIR
IMPACT WRENCH

Max torque
at 5 seconds : 1400 ft-lb
Net weight : 5.0kg

- Twin hammer type



M7-NC6218
3/4" DRIVE AIR
IMPACT WRENCH

Max torque at 5 seconds : 1500 ft-lb
Net weight : 5.7kg

- Twin hammer type



**FOR IMPACT SOCKETS SEE PAGES
270 - 292**



Part No.	Square Drive	Bolt Capacity	Torque Range		Max Torque at 5 seconds		Free Speed			Air Requirement			Overall Length	Net Weight	Sound Pressure	Vibration Level
	Inch		ft-lb	Nm	ft-lb	Nm	RPM	CFM	PSI	Inlet	mm	kg				
M7-NC6236Q	3/4"	1" (25)	200-900	271-1220	1200	1627	7500	5.5	90	1/4"	171	2.68	83.0	4.5		
M7-NC6217	3/4"	1-1/8" (30)	200-1300	271-1762	1400	1898	4800	5.4	90	1/2"	215	5.0	92.0	6.1		
M7-NC6218	3/4"	1-1/16" (27)	200-1400	271-1898	1500	2034	6000	6.34	90	1/4"	320	5.7	106	3.3		

1" DRIVE AIR IMPACT WRENCHES

M7-NC8212
1" DRIVE AIR
IMPACT WRENCH

Max torque
at 5 seconds : 1300ft-lb
Net weight : 4.4kg

- New twin hammer type



M7-NC8217
1" DRIVE AIR
IMPACT WRENCH

Max torque
at 5 seconds : 1500 ft-lb
Net weight : 5.0kg

- New twin hammer type



Part No.	Square Drive	Bolt Capacity	Torque Range		Max Torque at 5 seconds		Free Speed			Air Requirement			Overall Length	Net Weight	Sound Pressure	Vibration Level
	Inch		ft-lb	Nm	ft-lb	Nm	RPM	CFM	PSI	Inlet	mm	kg				
M7-NC8212	1"	1-1/16" (27)	200-1000	271-1356	1300	1762	6000	6	90	3/8"	235	4.4	91.2	5.0		
M7-NC8217	1"	1-1/4" (30)	200-1300	271-1762	1500	2034	4800	5.4	90	3/8"	222	5.0	92.0	6.1		



M7-NC8219
1" DRIVE AIR
IMPACT WRENCH

Max torque
at 5 seconds : 1800 ft-lb
Net weight : 9.84kg

- New twin hammer type
- Standard anvil



M7-NC8311 STANDARD ANVIL
M7-NC8351 8" ANVIL - PICTURED
1" DRIVE AIR IMPACT WRENCH

Max torque at 5 seconds : 1800 ft-lb
Net weight : 10.9kg

- Pin less type

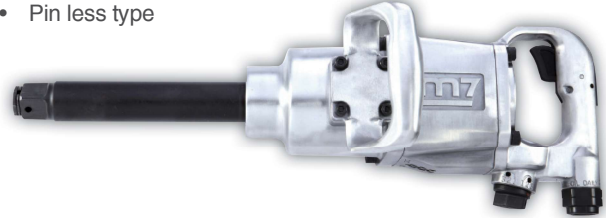

M7-NC8221 8" ANVIL
1" DRIVE AIR IMPACT WRENCH

Max torque at 5 seconds : 1800 ft-lb
Net weight : 11.5kg

- Twin hammer type



M7-NC8262 8" ANVIL
1" DRIVE AIR IMPACT WRENCH

Max torque at 5 seconds : 2400 ft-lb
Net weight : 13.5kg

- Pin less type
- Outside trigger



M7-NC8322 STANDARD ANVIL
M7-NC8342 8" ANVIL - PICTURED
1" DRIVE AIR IMPACT WRENCH

Max torque at 5 seconds : 2500 ft-lb
Net weight : 15.5kg

- Pin less type



M7-NC8382 STANDARD ANVIL
M7-NC8382-8 8" ANVIL- PICTURED
1" DRIVE AIR IMPACT WRENCH

Max torque at 3 seconds : 2400 ft-lb
Max torque at 5 seconds : 2710 ft-lb
Net weight : 11kg

- Pin less type
- Lightest 2500+ ft-lb impact wrench in the world
- Mighty spring in the cylinder increases the air efficiency



Part No.	Square Drive	Bolt Capacity	Torque Range		Max Torque at 5 seconds		Free Speed	Air Requirement			Overall Length	Net Weight	Sound Pressure	Vibration Level
	Inch		Inch (mm)	ft-lb	Nm	ft-lb		Nm	RPM	CFM				
M7-NC8219	1"	1-7/16" (36)	200-1600	271-2170	1800	2441	4000	11	90	1/2"	315	9.84	103.4	16.7
M7-NC8311	1"	1-3/8" (33)	200-1600	271-2170	1800	2441	4000	11.5	90	1/2"	380	10.9	101	7.3
M7-NC8351	1"	1-3/8" (33)	200-1600	271-2170	1800	2441	4000	11.5	90	1/2"	510	12.5	101	7.3
M7-NC8221	1"	1-3/8" (33)	200-1600	271-2170	1800	2441	5000	10	90	1/2"	530	11.5	100	10.0
M7-NC8262	1"	1-7/16" (36)	200-2000	271-2710	2400	3254	4000	10	90	1/2"	590	13.5	100	10.0
M7-NC8322	1"	1-7/16" (36)	200-2000	271-2710	2500	3390	3300	11	90	1/2"	440	15.5	93.9	8.8
M7-NC8342	1"	1-7/16" (36)	200-2000	271-2710	2500	3390	3300	11	90	1/2"	619	17.3	93.9	8.8
M7-NC8382	1"	1-9/16" (39.7)	200-2000	271-2710	2500	3390	5000	15.9	90	1/2"	370	11.0	100	6.4
M7-NC8382-8	1"	1-9/16" (39.7)	200-2000	271-2710	2500	3390	5000	15.9	90	1/2"	570	12.5	100	6.4

Magnetic Base Drilling Machines

Cutting Tools

Clamps

Engineer's Tools

Sharpening Machines

Metal Cutting Saws

Drilling Machines

Bevelling Machines & Welding Carriages

Punches & Shears

Grinding Machines

Fans & Ventilators

Workshop Storage

M7 Airtools

NPK Airtools

Pneumatic Products





M7-NC8237 STANDARD ANVIL - PICTURED
M7-NC8237-6 6" ANVIL
1" DRIVE AIR IMPACT WRENCH

Free speed : 4500 RPM
 Max torque at
 5 seconds : 1800 ft-lb

- Twin hammer type
- D handle



M7-NC8216 STANDARD ANVIL
M7-NC8226 6" ANVIL - PICTURED
1" DRIVE AIR IMPACT WRENCH

Free speed : 6000 RPM
 Max torque at 5 seconds : 1800 ft-lb

- Twin hammer type
- D handle



M7-NC8242 STANDARD ANVIL - PICTURED
M7-NC8242-8 8" ANVIL
1" DRIVE AIR IMPACT WRENCH

Free speed : 5000 RPM
 Max torque at 5 seconds : 2500 ft-lb

- Twin hammer type
- D handle
- Lightest 2500 ft-lb impact wrench in the world
- Mighty Spring in the cylinder increase the air efficiency
- High torque out put: 3 seconds. for 2400FT-LB, over 2700 ft-lb in 5 seconds



M7-NC8252
1" DRIVE AIR IMPACT WRENCH

Free speed : 5000 RPM
 Max torque at 5 seconds : 2400 ft-lb
 Net weight : 10.5kg

- Twin hammer type
- D handle
- Pin less type
- Outside trigger



M7-NC8343-8
1" DRIVE AIR IMPACT WRENCH

Free speed : 3900 RPM
 Max torque at 5 seconds : 1800 ft-lb
 Net weight : 13.9kg

- D handle
- Outside trigger



Part No.	Square Drive	Bolt Capacity	Torque Range		Max Torque at 5 seconds		Free Speed	Air Requirement			Overall Length	Net Weight	Sound Pressure	Vibration Level
	Inch		Inch (mm)	ft-lb	Nm	ft-lb		Nm	RPM	CFM				
M7-NC8237	1"	1-3/8" (33mm)	200-1500	271-2034	1800	2441	4500	5.4	90	3/8"	222	5.7	92.0	6.1
M7-NC8237-6	1"	1-3/8" (33mm)	200-1500	271-2034	1800	2441	4500	5.4	90	3/8"	395	6.5	92.0	6.1
M7-NC8216	1"	1-3/8" (33mm)	200-1600	271-2170	1800	2441	6000	9.0	90	1/2"	343	7.0	102.0	9.3
M7-NC8226	1"	1-3/8" (33mm)	200-1600	271-2170	1800	2441	6000	9.0	90	1/2"	487	8.4	102.0	9.3
M7-NC8242	1"	1-9/16" (40mm)	200-2000	271-2710	2500	3390	5000	15.9	90	1/2"	370	10.5	100.0	6.4
M7-NC8242-8	1"	1-9/16" (40mm)	200-2000	271-2710	2500	3390	5000	15.9	90	1/2"	570	11.9	100.0	6.4
M7-NC8252	1"	1-7/16" (36mm)	200-2000	271-2170	2400	3250	4000	10.0	90	1/2"	390	12.1	100.0	10.0
M7-NC8343-8	1"	1-3/8" (33mm)	200-1600	271-2170	1800	2441	3900	11.5	90	1/2"	590	13.9	103.0	6.3



1-1/2" DRIVE AIR IMPACT WRENCHES

M7-NC9223 STANDARD ANVIL - PICTURED
M7-NC9243 8" ANVIL
1-1/2" DRIVE AIR IMPACT WRENCH



Max torque at 5 seconds : 3500 ft-lb
 Net weight : 19.7kg
 • New twin hammer type

Part No.	Square Drive	Bolt Capacity	Torque Range		Max Torque at 5 seconds		Free Speed	Air Requirement			Overall Length	Net Weight	Sound Pressure	Vibration Level
	Inch	Inch (mm)	ft-lb	Nm	ft-lb	Nm	RPM	CFM	PSI	Inlet	mm	kg	dBA	m/s ²
M7-NC9223	1-1/2"	2" (50)	200-3000	271-4065	3500	4746	3000	16.0	90	1/2"	450	19.7	104.5	8.8
M7-NC9243	1-1/2"	2" (50)	200-3000	271-4065	3500	4746	3000	16.0	90	1/2"	616	22.8	104.5	8.8

AIR ANGLE DRIVE IMPACT RATCHETS

M7-NE399
3/8" AIR ANGLE DRIVE IMPACT RATCHET
M7-NE499
1/2" AIR ANGLE DRIVE IMPACT RATCHET

Net weight : 1.83kg
 • Mighty innovative, convenient forward & reverse ring control.
 • Mighty small, easy to reach narrow spaces.

M7-NE499N
1/2" AIR ANGLE DRIVE IMPACT RATCHET SET

Includes:
 • M7-NE499 1/2" drive air ratchet wrench (see left)
 • 9, 10, 11, 13, 14, 17, 19, 22 & 24mm impact sockets
 • 1/4" plug



Part No.	Square Drive	Bolt Capacity	Torque Range		Max Torque at 5 seconds		Free Speed	Air Requirements			Overall Length	Net Weight	Sound Pressure	Vibration Level
	Inch	Inch (mm)	ft-lb	Nm	ft-lb	Nm	RPM	CFM	PSI	Inlet	mm	kg	dBA	m/s ²
M7-NE399	3/8"	1/2" (13)	50-130	68-176	180	244	7500	2.54	90	1/4"	340	1.83	93	9.9
M7-NE499	1/2"	9/16" (14)	50-150	68-203	250	339	7500	2.54	90	1/4"	340	1.83	93	9.9

Part No.	Description
M7-NE499N	Ratchet Set, 11pce, 1/2" Drive, 250 ft-lb

**FOR IMPACT SOCKETS
 SEE PAGES 270 - 292**





M7-NE462TA
1/2" DRIVE AIR ANGLE
IMPACT WRENCH

Free speed : 200 RPM
 Net weight : 1.83kg



Part No.	Square Drive	Torque Range		Max Torque at 5 seconds		Free Speed	Air Requirement			Overall Length	Net Weight	Sound Pressure	Vibration Level
	Inch	ft-lb	Nm	ft-lb	Nm	RPM	CFM	PSI	Inlet	mm	kg	dBA	m/s ²
M7-NE462TA	1/2"	10-65	13.5-88	100	135	200	5.0	90	1/4"	340	1.83	85.0	2.5

Magnetic Base Drilling Machines

Cutting Tools

Clamps

Engineer's Tools

Sharpening Machines

Metal Cutting Saws

Drilling Machines

Bevelling Machines & Welding Carriages

Punches & Shears

Grinding Machines

Fans & Ventilators

Workshop Storage

M7
Airtools

NPK Airtools

Pneumatic Products



AIR RATCHET WRENCHES

M7-NE251R
1/4" DRIVE MINI AIR RATCHET WRENCH
M7-NE351R
3/8" DRIVE MINI AIR RATCHET WRENCH

Max torque at 5 seconds : 22 ft-lb
Net weight : 0.5kg



M7-NE332
3/8" DRIVE AIR RATCHET WRENCH
M7-NE432
1/2" DRIVE AIR RATCHET WRENCH

Max torque at 5 seconds : 60 ft-lb
Net weight : 1.22kg



M7-NE0357
3/8" DRIVE AIR RATCHET WRENCH SET

Includes:

- 1pc 3/8" drive air ratchet wrench (M7-NE352)
- 7pcs 1/4" drive socket : 4, 5, 6, 7, 8, 9, 10mm
- 6pcs 3/8" drive socket : 11, 12, 13, 14, 15, 17mm
- 40 pcs 1/4" bits
- 1pc 3/8" extension bar
- 1pc 1/4" hex shank driver
- 1pc plug (adaptor)



M7-NE0413
1/4" DRIVE AIR RATCHET WRENCH KIT
THRU HOLE TYPE

Max torque at 5 seconds : 100 ft-lb

13pcs kit contains :

- 1pc air ratchet wrench (M7-NE461)
- 8pcs 1/2" hex thru-hole socket : 8, 9, 10, 12, 13, 14, 17, 19mm
- 1pc 3" extension bar
- 1pc 3/8" adaptor for standard sockets
- 1pc 1/2" adaptor for standard sockets
- 1pc plug (adaptor)

Optional imperial thru-hole sockets available



Part No.	Square Drive	Torque Range		Max Torque at 5 seconds		Free Speed RPM	Air Requirements			Overall Length mm	Net Weight kg	Sound Pressure dBA	Vibration Level m/s ²
	Inch	ft-lb	Nm	ft-lb	Nm		CFM	PSI	Inlet				
M7-NE251R	1/4"	5-15	6.7-20	22	30	350	3	90	1/4"	125	0.5	89	4.4
M7-NE351R	3/8"	5-15	6.7-20	22	30	350	3	90	1/4"	125	0.5	89	4.4
M7-NE332	3/8"	10-45	13.5-61	60	81	160	4	90	1/4"	265	1.22	90.5	4.4
M7-NE432	1/2"	10-45	13.5-61	60	81	160	4	90	1/4"	265	1.22	89.8	5.2
Part No.	Description												
M7-NE0357	Ratchet Wrench Set, 57 pce, 3/8" DR (M7-NE352 Same Specifications As M7-NE351)												
M7-NE0413	Ratchet Wrench Set, Thru-Hole, 13 pce, 1/2" DR, 100 ft-lb												

Magnetic Base Drilling Machines

Cutting Tools

Clamps

Engineer's Tools

Sharpening Machines

Metal Cutting Saws

Drilling Machines

Bevelling Machines & Welding Carriages

Punches & Shears

Grinding Machines

Fans & Ventilators

Workshop Storage

M7 Airtools

NPK Airtools

Pneumatic Products





M7-NE483
1/2" DRIVE AIR
RATCHET WRENCH

Free speed : 250 RPM
 Net weight : 1.28kg



M7-NE488
1/2" DRIVE AIR
RATCHET WRENCH

Free speed : 150 RPM
 Net weight : 1.45kg



Part No.	Square Drive	Torque Range		Max Torque at 5 seconds		Free Speed	Air Requirement			Overall Length	Net Weight	Sound Pressure	Vibration Level
	Inch	ft-lb	Nm	ft-lb	Nm	RPM	CFM	PSI	Inlet	mm	kg	dBA	m/s ²
M7-NE483	1/2"	10-65	13.5-61	100	81	250	5.0	90	1/4"	277	1.28	85.0	2.5
M7-NE488	1/2"	10-40	13.5-54	60	81	150	4.5	90	1/4"	275	1.45	85.0	3.9



M7-NE362 3/8" DRIVE MINI AIR RATCHET WRENCH



Max torque at 5 seconds : 37 ft-lb
Net weight : 0.5kg

- Rear exhaust design to reduce flying dust
- Dual-use square drive for 1/4" hex shank screwdriver bits
- 160mm length
- Narrow design for reaching tight spaces



M7-NE343 3/8" DRIVE AIR RATCHET WRENCH



Max torque at 5 seconds : 75 ft-lb
Net weight : 1.30kg



M7-NE443 1/2" DRIVE AIR RATCHET WRENCH



Max torque at 5 seconds : 100 ft-lb
Net weight : 1.30kg



Part No.	Square Drive	Torque Range		Max Torque at 5 seconds		Free Speed	Air Requirements			Overall Length	Net Weight	Sound Pressure	Vibration Level
		Inch	ft-lb	Nm	ft-lb		Nm	RPM	CFM				
M7-NE362	3/8"	10-35	13.5-47	37	50	230	4.6	90	1/4"	160	0.5	88	3.0
M7-NE343	3/8"	10-55	13.5-74	75	101.7	160	4	90	1/4"	280	1.3	84	4.4
M7-NE443	1/2"	10-55	13.5-74	100	135.6	160	4	90	1/4"	280	1.3	84	4.4

AIR HYDRAULIC RIVET NUT TOOLS

M7-PB2402 AIR HYDRAULIC NUT TOOL

Stroke : 0 - 9mm
Net weight : 1.55kg
Suitable for use with :

- Steel M4 - M10
 - Stainless steel M4 - M8
- Comes with mandrel sizes :
M4, M5, M6, M8 & M10



M7-PB2501 AIR HYDRAULIC RIVET NUT TOOL

Stroke : 0 - 6.5mm
Net weight : 2.5kg
Comes with mandrel sizes :
M3, M4, M5, M6, M8, M10 & M12



Part No.	Traction Power		Stroke Length	Capacity	Air Requirements				Overall Length	Net Weight	Sound Pressure	Vibration Level
	lbf	kgf			mm	mm	L/cycle	PSI				
M7-PB2402	3638	1650	9	Steel M4 - M10 Stainless Steel M4 - M8	1.5	90	-	1/4"	163	1.55	82	0.8
M7-PB2501	4630	2100	6.5	M3 - M12	-	90	7.5	1/4"	310	2.5	80.0	2.5



AIR RIVET NUT TOOLS

M7-PB1305 M3 & M5, 1200RPM

M7-PB1308 M6 & M8, 600RPM

M7-PB1310 M8 & M10, 400RPM

QUICK RELEASE AIR RIVET NUT TOOLS

- Automatic mechanism to quickly push up and pull back rivet
- Quick release clip design to change spindle easily
- Two trigger design for quick forward / reverse operation



M7-PB1312 AIR RIVET NUT TOOLS

Capacity : M10 & M12
Free speed : 400 RPM



Part No.	Capacity	Free Speed	Air Requirements			Net Weight	Sound Pressure	Vibration Level
	mm	RPM	PSI	CFM	Inlet	kg	dBA	m/s ²
M7-PB1305	M3 & M5	1200	90	7.8	1/4"	1.10	86	1.6
M7-PB1308	M6 & M8	600	90	7.8	1/4"	1.30	86	1.6
M7-PB1310	M8 & M10	400	90	7.8	1/4"	1.74	86	1.6
M7-PB1312	M10 & M12	400	90	7.8	1/4"	1.28	86	1.6

AIR TAPPERS

M7-PC1012 AIR TAPPER

Suitable for use with :

- Aluminium M3 - M12
- Copper M3 - M12
- Steel M3 - M10
- Stainless Steel M3 - M10
- Does not include collets or taps



M7-PC1012KIT AIR TAPPER KIT

Includes M3, M4, M5, M6, M8, M10 & M12 collets
• Does not include taps



COLLETS

For use with M7-PC1012

- Does not include taps



Part No.	Suits Tap Diameters
M7A-PC1012T40	3mm & 1/8"
M7A-PC1012T50	4mm & 5/32"
M7A-PC1012T55	5mm & 3/16"
M7A-PC1012T60	6mm & 1/4"
M7A-PC1012T62	8mm & 5/16"
M7A-PC1012T70	10mm & 3/8"
M7A-PC1012T85	12mm & 7/16"

Part No.	Free Speed	Capacity	Air Inlet	Overall Length	Net Weight	Sound Pressure	Vibration Level
	RPM	mm	Inch	mm	kg	dBA	m/s ²
M7-PC1012	360	Aluminium : M3 - M12 Copper : M3 - M12 Steel : M3 - M10	1/4"	265	2.3	89	1.5
Part No.	Description						
M7-PC1012KIT	M7-PC1012 Air Tapper With M3, M4, M5, M6, M8, M10 & M12 Collets						





AIR TAPPERS

M7-PC2010 ADJUSTABLE TORQUE AIR TAPPER

- Adjustable clutch
 - Reversible
- Suitable for use with :
- M3 - M12 (Aluminium)
 - M3 - M12 (Copper)
 - M3 - M10 (Steel)
 - M3 - M10 (Stainless Steel)
- Weight : 2.45kg



M7-PC901 ADJUSTABLE TORQUE AIR TAPPING CHUCK

Capacity : M3-6.35
Weight : 0.6kg



Part No.	Free Speed	Capacity	Air Requirement			Overall Length	Net Weight	Sound Pressure		Vibration Level
	RPM		CFM	PSI	Inlet			mm	kg	
M7-PC2010	150	M3 - M12 (Aluminium) M3 - M12 (Copper) M3 - M10 (Steel) M3 - M10 (Stainless Steel)	6.5	90	1/4"	305	2.45	82.0	1.5	
M7-PC901	-	M3 - 6.35	-	-	-	-	0.6	-	-	

Magnetic Base Drilling Machines

Cutting Tools

Clamps

Engineer's Tools

Sharpening Machines

Metal Cutting Saws

Drilling Machines

Bevelling Machines & Welding Carriages

Punches & Shears

Grinding Machines

Fans & Ventilators

Workshop Storage

M7 Airtools

NPK Airtools

Pneumatic Products





AIR HYDRAULIC RIVETERS

M7-PA301 AIR HYDRAULIC RIVETER

Traction power : 2303 lbf
Alloy rivet diameter :
3/32" (2.4mm) - 3/16" (4.8mm)
Stroke length : 16mm
Net weight : 1.5kg



M7-PA301V EXTERNAL HOSE M7-PA301MV INTERNAL HOSE VACUUM TYPE AIR HYDRAULIC RIVETER

Traction power : 2303 lbf
Alloy rivet diameter :
3/32" (2.4mm) - 3/16" (4.8mm)
Stroke length : 16mm



M7-PA321 AIR HYDRAULIC RIVETER

Traction power : 2612 lbf
Alloy rivet diameter :
3/32" (2.4mm) - 3/16" (4.8mm)
Stroke length : 22mm
Net weight : 1.5kg



M7-PA211 AIR HYDRAULIC RIVETER

Traction power : 3748 lbf
Alloy rivet diameter :
3/32" (2.4mm) - 1/4" (6.4mm)
Stroke length : 18mm
Net weight : 1.75kg



M7-PA211TS AIR HYDRAULIC RIVETER FOR TRUCK BRAKE SHOES

Traction power : 3748 lbf
Alloy rivet diameter :
3/32" (2.4mm) - 1/4" (6.4mm)
Stroke length : 18mm
Net weight : 1.75kg



M7-PA201 AIR HYDRAULIC RIVETER

Traction power : 3534 lbf
Alloy rivet diameter :
3/32" (2.4mm) - 1/4" (6.4mm)
Stroke length : 14mm
Net weight : 1.8kg



M7-PA111 AIR HYDRAULIC RIVETER

Traction power : 4100 lbf
Alloy rivet diameter :
5/32" (4.0mm) - 5/16" (8.0mm)
Stroke length : 26mm
Net weight : 3.0kg



Part No.	Traction Power		Stroke Length	Capacity	Air Requirement			Net Weight	Sound Pressure	Vibration Level	Maximum Rivet Diameter							
	lb.f	kgf			PSI	CFM	Inlet				kg	dBa	m/s ²	Aluminium Rivet & Aluminium Mandrel	Aluminium Rivet & Steel Mandrel	Steel Rivet & Steel Mandrel	Stainless Rivet & Steel Mandrel	Stainless Rivet & Stainless Mandrel
	mm	mm			inch (mm)	inch (mm)	inch (mm)				inch (mm)	inch (mm)	inch (mm)	inch (mm)	inch (mm)	inch (mm)	inch (mm)	
M7-PA301	2303	1045	16	2.4-4.8	90	1.48	1/4"	1.5	79.7	0.3	3/16" (4.8)	3/16" (4.8)	3/16" (4.8)	5/32" (4.0)	5/32" (4.0)			
M7-PA301V	2303	1045	16	2.4-4.8	90	1.48	1/4"	1.5	79.7	0.3	3/16" (4.8)	3/16" (4.8)	3/16" (4.8)	5/32" (4.0)	5/32" (4.0)			
M7-PA301MV	2303	1045	16	2.4-4.8	90	1.48	1/4"	1.75	79.7	0.3	3/16" (4.8)	3/16" (4.8)	3/16" (4.8)	3/16" (4.8)	5/32" (4.0)			
M7-PA321	2612	1185	22	2.4-4.8	90	1.48	1/4"	1.5	79.7	0.4	3/16" (4.8)	3/16" (4.8)	3/16" (4.8)	3/16" (4.8)	3/16" (4.8)			
M7-PA211	3748	1700	18	2.4-6.4	90	2.9	1/4"	1.75	79.7	0.8	1/4" (6.4)	1/4" (6.4)	1/4" (6.4)	1/4" (6.4)	1/4" (6.4)			
M7-PA211TS	3748	1700	18	2.4-6.4	90	2.9	1/4"	1.75	79.7	0.8	1/4" (6.4)	1/4" (6.4)	1/4" (6.4)	1/4" (6.4)	1/4" (6.4)			
M7-PA201	3534	1603	14	2.4-6.4	90	2.32	1/4"	1.8	79.7	0.5	1/4" (6.4)	1/4" (6.4)	1/4" (6.4)	3/16" (4.8)	3/16" (4.8)			
M7-PA111	4100	1860	26	4.0-8.0	90	2.88	1/4"	3.0	82.0	0.8	5/16" (8.0)	5/16" (8.0)	5/16" (8.0)	9/32" (7.2)	9/32" (7.2)			



Rivet (D1)	Mandrel (L1)	Mandrel dia. (D2)
2.4mm	27mm	1.42 - 1.51
3.2mm	28mm	1.83 - 1.92
4.0mm	29mm	2.28 - 2.42
4.8mm	30mm	2.64 - 2.91
6.4mm	30mm	3.84 - 4.15

			Rivet Diameter (D1)							
Rivet	Rivet Material	Mandrel Material	2.4	3.2	4.0	4.8	6.4	7.2	8.0	
M7-PA301 M7-PA301V	aluminium	aluminium	✓	✓	✓	✓				
	aluminium	steel	✓	✓	✓	✓				
	steel	steel	✓	✓	✓	✓				
	stainless	steel	✓	✓	✓	✓				
	stainless	stainless	✓	✓	✓	✓				
M7-PA301MV	aluminium	aluminium	✓	✓	✓	✓				
	aluminium	steel	✓	✓	✓	✓				
	steel	steel	✓	✓	✓	✓				
	stainless	steel	✓	✓	✓	✓				
	stainless	stainless	✓	✓	✓	✓				
M7-PA321	aluminium	aluminium	✓	✓	✓	✓				
	aluminium	steel	✓	✓	✓	✓				
	steel	steel	✓	✓	✓	✓				
	stainless	steel	✓	✓	✓	✓				
	stainless	stainless	✓	✓	✓	✓				
M7-PA211	aluminium	aluminium	✓	✓	✓	✓	✓			
	aluminium	steel	✓	✓	✓	✓	✓			
	steel	steel	✓	✓	✓	✓	✓			
	stainless	steel	✓	✓	✓	✓	✓			
	stainless	stainless	✓	✓	✓	✓	✓			
M7-PA211TS	aluminium	aluminium	✓	✓	✓	✓	✓			
	aluminium	steel	✓	✓	✓	✓	✓			
	steel	steel	✓	✓	✓	✓	✓			
	stainless	steel	✓	✓	✓	✓	✓			
	stainless	stainless	✓	✓	✓	✓	✓			
M7-PA201	aluminium	aluminium	✓	✓	✓	✓	✓			
	aluminium	steel	✓	✓	✓	✓	✓			
	steel	steel	✓	✓	✓	✓	✓			
	stainless	steel	✓	✓	✓	✓	✓			
	stainless	stainless	✓	✓	✓	✓	✓			
M7-PA111	aluminium	aluminium				✓	✓	✓		
	aluminium	steel				✓	✓	✓		
	steel	steel				✓	✓	✓		
	stainless	steel				✓	✓	✓		
	stainless	stainless				✓	✓	✓		

M7A-PAMC AUTOMATIC MANDREL COLLECTION

For use with M7-PA301V and M7-PA301MV

Capacity :

- 3/32" (2.4mm) 220pcs
- 1/8" (3.2mm) 160pcs
- 5/32" (4.0mm) 110pcs
- 3/16" (4.8mm) 80pcs



Part No.	Description
M7A-PAMC	Automatic Mandrel Collection For Use With M7-PA301V and M7-PA301MV



RIVETER ADAPTORS

M7A-PA9048P RIVETER ADAPTOR



Nose Piece : 2.4mm, 3.2mm, 4.0mm, 4.8mm
Net Weight : 0.3kg
Hex Shank : 1/4"

- For use with 3/8" 12V, 14.4V & 18V cordless drills.
- Suitable for aluminium, aluminium/steel and all steel rivets.
- Not suitable for stainless steel rivets.



M7A-PA9064 RIVETER ADAPTOR



Nose Piece : 3.2mm, 4.0mm, 4.8mm, 6.4mm
Net Weight : 0.3kg
Hex Shank : 1/4"

- For use with 1/2" 14.4V & 18V cordless drills.
- Suitable for aluminium, aluminium/steel and all steel rivets.
- Not suitable for stainless steel rivets.



Part No.	Nose Piece	Recommended Free Speed	Min. Torque	Dimensions	Net Weight
	mm	RPM	Nm	mm	kg
M7A-PA9048P	2.4, 3.2, 4.0, 4.8	1000	11	59 x 158	0.3
M7A-PA9064	3.2, 4.0, 4.8, 6.4	1000	50	59 x 173	0.3

RIVET NUT ADAPTORS

M7A-PB9006P M6 RIVET NUT ADAPTOR



Nose Piece : M3, M4, M5, M6
Net Weight : 0.28kg
Hex Shank : 1/4"
For use with 3/8" 12V
& 14.4V cordless drills



M7A-PB9010 M10 RIVET NUT ADAPTOR



Nose Piece : M6, M8, M10
Net Weight : 0.35kg
Hex Shank : 1/4"
For use with 3/8" 12V
& 14.4V cordless drills



Part No.	Nose Piece	Recommended Free Speed	Min. Torque	Dimensions	Net Weight
	mm	RPM	Nm	mm	kg
M7A-PB9006P	M3, M4, M5, M6	1000	15	59 x 172	0.28
M7A-PB9010	M6, M8, M10	800	100	59 x 180	0.35

M7 RIVETER & RIVET NUT ADAPTOR COUNTER TOP MERCHANDISERS



M7A-PA9048PT

Qty	Part No.	Description	Max. Nose Piece Size
8	M7A-PA9048P	Riveter Adaptor	4.8mm

M7A-PA48PB06PT

Qty	Part No.	Description	Max. Nose Piece Size
4	M7A-PA9048P	Riveter Adaptor	4.8mm
4	M7A-PB9006	Rivet Nut Adaptor	M6

M7A-PB9006PT

Qty	Part No.	Description	Max. Nose Piece Size
8	M7A-PB9006	Rivet Nut Adaptor	M6



AIR SHEET METAL CUTTERS

M7-QD291N AIR SAW SET

Stroke length : 10mm

- Quick change saw blade holder
- 5 piece file set and 12 saw blades are included
- Adjustable guard / guide controls depth of cut precisely

Contents

- 1pc Air saw tool
- 6pcs 24TPI saw blades
- 6pcs 32TPI saw blades
- 1pc Allen key: 4mm, 3mm
- 5pcs File set
- 1pc Mini oiler 1/4"



M7A-QD932 32TPI SAW BLADE M7A-QD924 24TPI SAW BLADE

- Bi-Metal



M7A-QD905 AIR SAW FILES

- Files to suit M7-QD291N



M7-QG102 AIR SHEAR - STRAIGHT TYPE

Net weight : 1kg
Aluminium sheet cut capacity : 1.6mm
Mild steel sheet cut capacity : 1.2mm
Stainless steel sheet cut capacity : 1.0mm



M7-QG202 AIR SHEAR - PISTOL TYPE

Net weight : 1.1kg
Aluminium sheet cut capacity : 1.6mm
Mild steel sheet cut capacity : 1.2mm
Stainless steel sheet cut capacity : 1.0mm



M7-QG103 AIR NIBBLER

Cut capacity aluminium : 1.6mm
Cut capacity steel : 1.2mm

Net weight : 1kg

- Strengthened punch for increased tool life
- Pull type cutting head for durability
- Rear exhaust



Part No.	Stroke Length	Strokes Per min.	Collet Size	Air Requirement			Overall Length	Net Weight	Sound Pressure	Vibration Level	Cut Capacity
	mm	S.P.M.		mm	CFM	PSI					
M7-QD291N	10	9000	5	4.0	90	1/4"	235	0.6	80.0	2.4	-
M7-QG102	-	2600	-	6.0	90	1/4"	254	1.0	85.8	2.4	1.6
M7-QG202	-	2600	-	6.5	90	1/4"	210	1.1	89.1	2.9	1.6
M7-QG103	-	2600	-	3.0	90	1/4"	193	1.0	88.0	2.8	1.6
Part No.	Description										
M7A-QD932	Saw Blade, 32TPI, To Suit M7-QD291N (Pack Of 10)										
M7A-QD924	Saw Blade, 24TPI, To Suit M7-QD291N (Pack Of 10)										
M7A-QD905	File Set, 5 Piece To Suit M7-QD291N										
M7A-QG103P38	Punch For M7-QG103 Nibbler										
M7A-QG103P40	Die For M7-QG103 Nibbler										

Magnetic Base Drilling Machines

Cutting Tools

Clamps

Engineer's Tools

Sharpening Machines

Metal Cutting Saws

Drilling Machines

Bevelling Machines & Welding Carriages

Punches & Shears

Grinding Machines

Fans & Ventilators

Workshop Storage

M7 Airtools

NPK Airtools

Pneumatic Products





**M7-QD321
AIR BODY SAW**

Stroke length : 14.5mm
Strokes Per Minute : 11000
Net weight : 0.6kg

- Special air flow design to reduce vibration
- Improved ergonomics to reduce fatigue
- Long stroke to increase work efficiency
- Heavy duty cylinder



Part No.	Stroke Length	Strokes Per min.	Air Requirement			Overall Length	Net Weight	Sound Pressure	Vibration Level
	mm	S.P.M.	CFM	PSI	Inlet	mm	kg	dBA	m/s ²
M7-QD321	14.5	11000	4.5	90	1/4"	230	0.6	83.0	2.0



AIR NAILERS

M7-SJ1650T C SERIES AIR NAILER

16 Gauge
Capacity : 100 nails
Weight : 2.35kg

Suitable for :

- Furniture manufacturing
- Kitchen / cabinet manufacture
- Fix-out
- Doors / windows

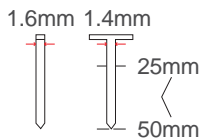

M7-SJ1830F C SERIES AIR NAILER

18 Gauge
Capacity : 100 nails

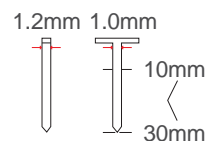

M7-SJ1850F C1 SERIES AIR NAILER

18 Gauge
Capacity : 100 nails
Weight : 1.4kg

Suitable for :

- Furniture manufacturing
- Kitchen / cabinet manufacture
- Flooring

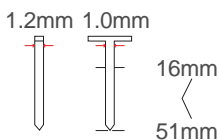

Part No.	Gauge	Series	Nail Length	Shank Thickness	Shank Width	Load Capacity	Net Weight	Working Pressure
			mm	mm	mm	Nails	kg	PSI
M7-SJ1650T	16	C	25 - 50	1.4	1.6	100	2.35	90
M7-SJ1830F	18	C	10 - 30	1.0	1.2	100	1.2	90
M7-SJ1850F	18	C1	16 - 51	1.0	1.2	100	1.4	90



M7-SJCN55 COIL NAILER

Shank diameter : 2.1 - 2.3mm
 Driving power : 36.54ft-lb
 Load capacity : 300 - 350 nails

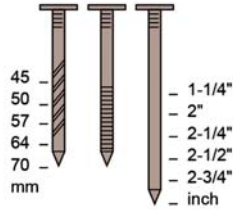

M7-SJCN70 COIL NAILER

Shank diameter : 2.3 - 2.9mm
 Driving power : 61.07ft-lb
 Load capacity : 150 - 300 nails

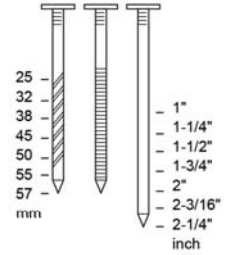

Part No.	Shank Diameter	Head Diameter	Nail Length	Collated	Driving Power	Load Capacity	Dimensions	Weight	Working Pressure
	mm	mm	mm		ft-lb	Nails	H x W x L mm	kg	PSI
M7-SJCN55	2.1 - 2.3	5.0 - 5.7	25 - 57	Wire	36.54	300 - 350	283 x 131 x 270	2.8	90
M7-SJCN70	2.3 - 2.9	5.7 - 7.0	25 - 57	Wire	61.07	150 - 300	303 x 129 x 307	3.7	90



AIR STAPLERS

M7-SU8016 AIR STAPLER

80 Series
Capacity : 100 staples
Weight : 0.96kg
Suitable for :

- Upholstery
- Picture framing
- Labelling / wrapping
- Furniture manufacturing
- Bed manufacturing
- Padding
- Insulation
- Coffin manufacture

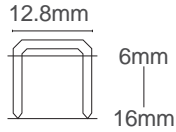

M7-SU9025 AIR STAPLER

90 Series
Capacity : 100 staples
Weight : 1.10kg
Suitable for :

- Furniture manufacturing
- Kitchen / cabinet manufacture
- Flooring

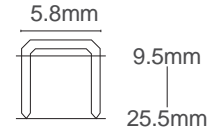

M7-SU9040 AIR STAPLER

90 Series
Capacity : 100 staples
Weight : 2.18kg
Suitable for :

- Furniture manufacturing
- Kitchen / cabinet manufacture
- Flooring

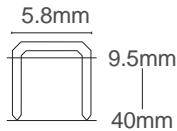

Part No.	Gauge	Series	Staple Length	Shank Thickness	Shank Width	Load Capacity	Net Weight	Working Pressure
			mm	mm	mm	Staples	kg	PSI
M7-SU8016	21	80	6 - 16	12.8	0.95 x 0.65	100	0.96	90
M7-SU9025	18	90	9.5 - 25.5	5.8	1.25 x 1.0	100	1.10	90
M7-SU9040	18	90	9.5 - 40	5.8	1.25 x 1.0	100	2.18	90

Magnetic Base Drilling Machines

Cutting Tools

Clamps

Engineer's Tools

Sharpening Machines

Metal Cutting Saws

Drilling Machines

Bevelling Machines & Welding Carriages

Punches & Shears

Grinding Machines

Fans & Ventilators

Workshop Storage

M7 Airtools

NPK Airtools

Pneumatic Products



AIR ANGLE GRINDERS

M7-QB114 100MM AIR ANGLE GRINDER M7-QB115 125MM AIR ANGLE GRINDER

Free speed : 11000 RPM

Net weight : 1.81kg

- Safety lever throttle
- 0.78HP motor for stall resistance
- Grinding wheel not included



M7-QB144 100MM AIR ANGLE GRINDER M7-QB145 125MM AIR ANGLE GRINDER



Free speed : 11000 RPM

Net weight : 1.81kg

- Roll throttle
- Grinding wheel not included



M7-QB7114 100MM AIR ANGLE GRINDER M7-QB7245 115MM AIR ANGLE GRINDER M7-QB7215 125MM AIR ANGLE GRINDER

Free speed : 11000 RPM

Net weight : 1.81kg

- Available with imperial or metric spindle sizes
- Safety lever throttle
- 1.3 HP motor for stall resistance
- One piece housing reduces maintenance costs
- Heavy duty air cooled spiral gears and double bearings for durability
- Swivel guard on 115mm & 125mm
- Grinding wheel not included



M7-QB117 180MM AIR ANGLE GRINDER

Free speed : 7000 RPM

Net weight : 3.24kg

- Safety lever throttle
- Spline drive system with locking bolt
- Grinding wheel not included



Part No.	Wheel Diameter	Spindle Size	Free Speed	Air Requirement			Overall Length	Rated Power	Net Weight	Sound Pressure	Vibration Level
	mm (Inch)			RPM	CFM	PSI					
M7-QB114	100 (4")	3/8"-24	11000	6.0	90	1/4"	230	0.78	1.81	87.8	1.20
M7-QB115	125 (5")	3/8"-24	11000	6.0	90	1/4"	230	0.78	1.81	87.1	1.20
M7-QB144	100 (4")	M10 x 1.5	11000	6.0	90	1/4"	226	0.78	1.81	87.8	1.20
M7-QB145	125 (5")	M14 x 2.0	11000	6.0	90	1/4"	226	0.78	1.81	87.8	1.20
M7-QB7114	100 (4")	3/8"-24	11000	4.2	90	1/4"	232	1.30	1.81	90.0	5.79 (A)
M7-QB7114M	100 (4")	M10 x 1.5	11000	4.2	90	1/4"	232	1.30	1.81	90.0	5.79 (A)
M7-QB7245	112 (4-1/2")	5/8"-11	11000	4.2	90	1/4"	232	1.30	1.81	90.0	6.57 (A)
M7-QB7245M	112 (4-1/2")	M14 x 2.0	11000	4.2	90	1/4"	232	1.30	1.81	90.0	6.57 (A)
M7-QB7215	125 (5")	5/8"-11	11000	4.2	90	1/4"	232	1.30	1.81	90.0	7.06 (A)
M7-QB7215M	125 (5")	M14 x 2.0	11000	4.2	90	1/4"	232	1.30	1.81	90.0	7.06 (A)
M7-QB117	188 (7")	SPLINE	7000	9.0	90	3/8"	343	1.00	3.24	89.7	1.00



M7-QB177 180MM AIR ANGLE GRINDER

- Free speed : 7600 RPM
Net weight : 3.3kg
- Safety lever throttle
 - Grinding wheel not included



M7-QB197Q 180MM AIR ANGLE GRINDER

- Free speed : 7000 RPM
Net weight : 3.1kg
- Safety lever throttle
 - Grinding wheel not included



**M7A-QB197P74
FIBRE DISC
BACKING PAD**
For use with M7-QB197Q



Part No.	Wheel Diameter	Spindle Size	Free Speed	Air Requirement			Overall Length	Rated Power	Net Weight	Sound Pressure	Vibration Level
	mm (Inch)			RPM	CFM	PSI					
M7-QB177	180 (7")	5/8"-11	7600	6.0	90	3/8"	170	2.00	3.30	92.0	2.7
M7-QB177M	180 (7")	M14 x 2.0	7600	6.0	90	3/8"	170	2.00	3.30	92.0	2.7
M7-QB197Q	180 (7")	5/8"-11	7000	6.0	90	3/8"	353	2.2	3.1	77.0	1.5
M7-QB197QM	180 (7")	M14 x 2.0	7000	6.0	90	3/8"	353	2.2	3.1	77.0	1.5
Part No.	Description										
M7A-QB197P74	Fibre Disc Backing Pad, HD Rubber, To Suit M7-QB197Q										
M7P-QB197P49A	M7 Thin Wheel Flange, 5/8"-11, To Suit M7-QB197Q Angle Grinder										

AIR VERTICAL GRINDERS

M7-QB185 125MM AIR VERTICAL GRINDER

- Free speed : 12000 RPM
Net weight : 2.8kg
- Safety lever throttle
 - Grinding wheel not included



M7-QB187 180MM AIR VERTICAL GRINDER

- Free speed : 7000 RPM
Net weight : 4.0kg
- Safety lever throttle
 - Grinding wheel not included



Part No.	Wheel Diameter	Spindle Size	Free Speed	Air Requirement			Overall Length	Rated Power	Net Weight	Sound Pressure	Vibration Level
	mm (Inch)			RPM	CFM	PSI					
M7-QB185	125 (5")	5/8"-11	12000	6	90	3/8"	232	1.4	2.8	86.0	2.1
M7-QB187	180 (7")	5/8"-11	7000	6	90	3/8"	247	2.0	4.0	86.0	2.1

Magnetic Base Drilling Machines

Cutting Tools

Clamps

Engineer's Tools

Sharpening Machines

Metal Cutting Saws

Drilling Machines

Bevelling Machines & Welding Carriages

Punches & Shears

Grinding Machines

Fans & Ventilators

Workshop Storage

M7 Airtools

NPK Airtools

Pneumatic Products





MINI AIR ANGLE GRINDER

M7-QB623 50MM / 2" AIR ANGLE GRINDER

- Free speed : 19000 RPM
 Rated power : 0.4 HP
 Net weight : 0.52kg
- Mini angle grinder, only 160mm length
 - Comes with sanding pad



Part No.	Wheel Diameter	Free Speed	Air Requirement			Overall Length	Rated Power	Net Weight	Sound Pressure	Vibration Level
	mm (Inch)	RPM	CFM	PSI	Inlet	mm	HP	kg	dBA	m/s ²
M7-QB623	50 (2")	19000	8.1	90	1/4"	160	0.4	1.59	80.0	0.5

AIR CUT OFF TOOLS

M7-QC234 100MM AIR CORNER CUT OFF TOOL

- Free speed : 16000 RPM
 Net weight : 1.59kg



M7-QC213 75MM AIR CORNER CUT OFF TOOL

- Free speed : 20000 RPM
 Net weight : 0.8kg
 0.9hp high power motor
- Excellent for cutting rusted bolts, nuts, motor exhaust clamps or hangers, sheet metal, fibreglass etc.
 - Cutting wheel not included



Part No.	Wheel Diameter	Free Speed	Air Requirement			Overall Length	Rated Power	Net Weight	Sound Pressure	Vibration Level
	mm (Inch)	RPM	CFM	PSI	Inlet	mm	HP	kg	dBA	m/s ²
M7-QC234	100 (4")	16000	10	90	1/4"	355	0.9	1.59	85.0	5.0
M7-QC213	75 (3")	20000	10	90	1/4"	200	0.9	0.8	80.2	10.8

AIR WET GRINDER

M7-QB603 75MM AIR WET GRINDER

- Free speed : 4500 RPM
 Net weight : 2.2kg
- Water cooling and lubrication
 - Valve type throttle



Part No.	Wheel Diameter	Spindle Size	Free Speed	Air Requirement			Water Hose I.D.	Overall Length	Net Weight	Air Hose Length	Water Hose Length
	Inch (mm)		RPM	CFM	PSI	Inlet	Inch	mm	kg	m	m
M7-QB603	75 (3")	5/8"-11	4500	15.1	90	1/4"	3/16"	210	2.2	3.0	3.0



M7-QC264 100MM AIR CORNER CUT OFF TOOL

Free speed : 15000 RPM

Net weight : 1.1kg

0.5hp high power motor

- Excellent for cutting rusted bolts, nuts, motor exhaust clamps or hangers, sheet metal, fibreglass etc.
- Comes complete with cutting wheel



Part No.	Wheel Diameter	Free Speed	Air Requirement			Overall Length	Rated Power	Net Weight	Sound Pressure	Vibration Level
	mm (Inch)	RPM	CFM	PSI	Inlet	mm	HP	kg	dBa	m/s ²
M7-QC264	100 (4")	15000	5	90	1/4"	232	0.5	1.1	85.0	2.2

Magnetic Base Drilling Machines

Cutting Tools

Clamps

Engineer's Tools

Sharpening Machines

Metal Cutting Saws

Drilling Machines

Bevelling Machines & Welding Carriages

Punches & Shears

Grinding Machines

Fans & Ventilators

Workshop Storage

M7 Airtools

NPK Airtools

Pneumatic Products



AIR STRAIGHT GRINDERS

M7-QB2925 65MM AIR STRAIGHT GRINDER

- Free speed : 16000 RPM
 Net weight : 1.33kg
- Roll throttle
 - Grinding wheel not included



M7-QB2925L 65MM AIR STRAIGHT GRINDER

- Free speed : 16000 RPM
 Net weight : 1.33kg
- Safety lever throttle
 - Grinding wheel not included



M7A-QA163LP23BK 1/4" COLLET ASSEMBLY DIE GRINDER CONVERSION KIT

For use with M7-QB2925 and M7-QB2925L to convert the tool for use as a 1/4" Die Grinder (M7-QA163LB).



M7A-QA163LP23AK 6MM COLLET ASSEMBLY DIE GRINDER CONVERSION KIT

For use with M7-QB2925 and M7-QB2925L to convert the tool for use as a 6mm Die Grinder (M7-QA163LA).



Part No.	Wheel Diameter	Spindle Size	Free Speed	Air Requirement			Overall Length	Rated Power	Net Weight	Sound Pressure	Vibration Level
	mm			CFM	PSI	Inlet					
M7-QB2925	65 x 13 x 9.5	3/8"-16	16000	5.0	90	1/4"	270	0.9	1.33	90.0	2.8
M7-QB2925L	65 x 13 x 9.5	3/8"-16	16000	5.0	90	1/4"	315	0.9	1.39	90.0	2.8
Part No.	Description										
M7A-QA163LP23BK	1/4" Collet Assembly Die Grinder Conversion Kit										
M7A-QA163LP23AK	6mm Collet Assembly Die Grinder Conversion Kit										

Magnetic Base Drilling Machines

Cutting Tools

Clamps

Engineer's Tools

Sharpening Machines

Metal Cutting Saws

Drilling Machines

Bevelling Machines & Welding Carriages

Punches & Shears

Grinding Machines

Fans & Ventilators

Workshop Storage

M7 Airtools

NPK Airtools

Pneumatic Products





AIR DIE GRINDERS

M7-QA111A 6MM & 3MM COLLETS
M7-QA111B 1/4" & 1/8" COLLETS
AIR DIE GRINDER

Free speed : 25000 RPM
 Rated power : 0.3 HP
 Net weight : 0.38kg

- Metal front cap
- Safety lever throttle



M7-QA211A 6MM & 3MM COLLETS
M7-QA211B 1/4" & 1/8" COLLETS
AIR DIE GRINDER

Free speed : 20000 RPM
 Rated power : 0.9 HP
 Net weight : 0.65kg

- Metal front cap
- Safety lever throttle



M7-QA313B 1/4" & 1/8" COLLETS
EXTENDED AIR DIE GRINDER

Overall length : 235mm
 Free speed : 25000 RPM
 Rated power : 0.3 HP
 Net weight : 0.58kg

- Safety lever throttle



M7-QA131A 3MM COLLET
M7-QA141A 6MM COLLET
M7-QA131B 1/8" COLLET
M7-QA141B 1/4" COLLET
AIR DIE GRINDER



Free speed : 30000 RPM (M7-QA131)
 Free speed : 24000 RPM (M7-QA141)
 Rated power : 0.4 HP
 Net weight : 0.6kg

- All steel construction
- Roll throttle



M7-QA210A 6MM COLLET
M7-QA210B 1/4" COLLET
AIR DIE GRINDER QUICK RELEASE COLLET

Free speed : 20000 RPM
 Rated power : 0.9 HP
 Net weight : 0.65kg

- Metal front cap
- Safety lever throttle



M7-QA315B 1/4" & 1/8" COLLETS
EXTENDED AIR DIE GRINDER

Overall length : 280mm
 Free speed : 25000 RPM
 Rated power : 0.3 HP
 Net weight : 0.63kg

- Safety lever throttle



Part No.	Collet Size		Free Speed RPM	Air Requirement			Overall Length mm	Rated Power HP	Net Weight kg	Sound Pressure dBA	Vibration Level m/s ²
	mm	inch		CFM	PSI	Inlet					
M7-QA111A	6 & 3	-	25000	10.0	90	1/4"	155	0.3	0.38	81.5	1.8
M7-QA111B	-	1/4" & 1/8"	25000	10.0	90	1/4"	155	0.3	0.38	81.5	1.8
M7-QA131A	3	-	30000	14.0	90	1/4"	170	-	0.60	75.0	2.5
M7-QA141A	6	-	24000	14.0	90	1/4"	170	0.4	0.60	75.0	2.5
M7-QA131B	-	1/8"	30000	14.0	90	1/4"	170	-	0.60	75.0	2.5
M7-QA141B	-	1/4"	24000	14.0	90	1/4"	170	0.4	0.60	75.0	2.5
M7-QA211A	6 & 3	-	20000	10.0	90	1/4"	190	0.9	0.65	75.7	0.8
M7-QA211B	-	1/4" & 1/8"	20000	10.0	90	1/4"	190	0.9	0.65	75.7	0.8
M7-QA210A	6	-	20000	10.0	90	1/4"	190	0.9	0.65	75.7	0.8
M7-QA210B	-	1/4"	20000	10.0	90	1/4"	190	0.9	0.65	75.7	0.8
M7-QA313B	-	1/4" & 1/8"	25000	10.0	90	1/4"	235	0.3	0.58	81.5	1.8
M7-QA315B	-	1/4" & 1/8"	25000	10.0	90	1/4"	280	0.3	0.63	81.5	1.8



M7-QA110A 6MM & 3MM COLLETS
M7-QA110B 1/4" & 1/8" COLLETS
AIR DIE GRINDER

Free speed : 22000 RPM
 Rated power : 0.5 HP
 Net weight : 0.62kg
 • Safety lever throttle



M7-QA116A 6MM & 3MM COLLETS
M7-QA116B 1/4" & 1/8" COLLETS
EXTENDED AIR DIE GRINDER

Free speed : 22000 RPM
 Rated power : 0.5 HP
 Net weight : 1.15kg
 • Safety lever throttle



M7-QA141LA 6MM COLLET
M7-QA141LB 1/4" COLLET
AIR DIE GRINDER



Free speed : 24000 RPM
 Rated power : 0.4 HP
 Net weight : 0.6kg
 • All steel construction
 • Lever throttle
 • Front exhaust



M7-QA241A 6MM COLLET
M7-QA241B 1/4" COLLET
AIR DIE GRINDER

Free speed : 4000 RPM
 Rated power : 0.5 HP
 Net weight : 0.65kg



M7-QA1710B
EXTENDED LENGTH
HEAVY DUTY DIE GRINDER

Free Speed : 18000 RPM
 Length : 465mm
 Rated power : 0.4 HP
 Collet : 1/4"
 Net weight : 1.07kg
 • Adjustable length



M7-QA4507B
EXTENDED LENGTH
MICRO DIE GRINDER

Free Speed : 32000 RPM
 Length : 1500mm
 Rated power : 0.4 HP
 Collet : 1/4"
 Net weight : 0.4kg



Part No.	Collet Size		Free Speed RPM	Air Requirement			Overall Length mm	Rated Power HP	Net Weight kg	Sound Pressure dBA	Vibration Level m/s ²
	mm	inch		CFM	PSI	Inlet					
M7-QA110A	6 & 3	-	22000	5.0	90	1/4"	186	0.5	0.62	85.0	1.1
M7-QA110B	-	1/4" & 1/8"	22000	5.0	90	1/4"	186	0.5	0.62	85.0	1.1
M7-QA116A	6 & 3	-	22000	5.0	90	1/4"	345	0.5	1.15	85.0	1.8
M7-QA116B	-	1/4" & 1/8"	22000	5.0	90	1/4"	345	0.5	1.15	85.0	1.8
M7-QA141LA	6	-	24000	14.0	90	1/4"	170	0.4	0.60	75.0	2.5
M7-QA141LB	-	1/4"	24000	14.0	90	1/4"	170	0.4	0.60	75.0	2.5
M7-QA241A	6	-	4000	10.6	90	1/4"	190	0.5	0.65	75.0	0.87
M7-QA241B	-	1/4"	4000	10.6	90	1/4"	190	0.5	0.65	75.0	0.87
M7-QA1710B	-	1/4"	18000	5.0	90	1/4"	465	0.4	1.07	80.0	1.5
M7-QA4507B	-	1/4"	32000	4.0	90	1/4"	1500	-	0.4	85.0	1.2

Magnetic Base Drilling Machines

Cutting Tools

Clamps

Engineer's Tools

Sharpening Machines

Metal Cutting Saws

Drilling Machines

Bevelling Machines & Welding Carriages

Punches & Shears

Grinding Machines

Fans & Ventilators

Workshop Storage

M7 Airtools

NPK Airtools

Pneumatic Products





MICRO AIR DIE GRINDER

M7-QA441 HEAVY DUTY MICRO AIR DIE GRINDER

Collet size : 1/8" (3mm)
Free speed : 60000 RPM
Net weight : 0.21kg

- Stainless steel front housing
- Ideal for machining dies, molds or other restricted grinding applications



Part No.	Collet Size	Free Speed	Air Requirement			Overall Length	Net Weight	Sound Pressure	Vibration Level
	mm	RPM	CFM	PSI	Inlet	mm	kg	dBA	m/s ²
M7-PN250	1/8" (3)	60000	2	90	1/4"	135	0.21	71.0	1.0

Magnetic Base Drilling Machines

Cutting Tools

Clamps

Engineer's Tools

Sharpening Machines

Metal Cutting Saws

Drilling Machines

Bevelling Machines & Welding Carriages

Punches & Shears

Grinding Machines

Fans & Ventilators

Workshop Storage

M7 Airtools

NPK Airtools

Pneumatic Products



M7-QA143A 6MM COLLET

M7-QA143B 1/4" COLLET

SLIMLINE EXTENDED AIR DIE GRINDER

Overall length : 296mm
 Free speed : 24000 RPM
 Rated power : 0.4 HP
 Net weight : 0.90kg
 • Roll throttle



M7-QA151A 6MM COLLET

M7-QA151B 1/4" COLLET

AIR DIE GRINDER

Free speed : 18000 RPM
 Rated power : 0.9 HP
 Net weight : 0.80kg
 • Roll throttle



M7-QA163LA 6MM COLLET

M7-QA163LB 1/4" COLLET

EXTENDED AIR DIE GRINDER

Overall length : 350mm
 Free speed : 16000 RPM
 Rated power : 0.9 HP
 Net weight : 1.31kg
 • Safety lever throttle



M7P-QB2925P

**GUARD - STRAIGHT GRINDER
 CONVERSION KIT**

For use with M7-QA163LA and M7-QA163LB to convert the tool for use as an Air Straight Grinder (M7-QB2925).



Part No.	Collet Size		Free Speed RPM	Air Requirement			Overall Length mm	Rated Power HP	Net Weight kg	Sound Pressure dBA	Vibration Level m/s ²
	mm	inch		CFM	PSI	Inlet					
M7-QA143A	6	-	24000	14.0	90	1/4"	296	0.4	0.90	75.0	2.5
M7-QA143B	-	1/4"	24000	14.0	90	1/4"	296	0.4	0.90	75.0	2.5
M7-QA151A	6	-	18000	12.2	90	1/4"	177	0.9	0.80	75.0	2.1
M7-QA151B	-	1/4"	18000	12.2	90	1/4"	177	0.9	0.80	75.0	2.1
M7-QA163LA	6	-	16000	5.0	90	1/4"	350	0.9	1.31	75.0	2.8
M7-QA163LB	-	1/4"	16000	5.0	90	1/4"	350	0.9	1.31	75.0	2.8
Part No.	Description										
M7P-QB2925P	Guard - Straight Grinder Conversion Kit To Suit M7-QA163L										

Magnetic Base Drilling Machines

Cutting Tools

Clamps

Engineer's Tools

Sharpening Machines

Metal Cutting Saws

Drilling Machines

Bevelling Machines & Welding Carriages

Punches & Shears

Grinding Machines

Fans & Ventilators

Workshop Storage

M7 Airtools

NPK Airtools

Pneumatic Products



M7-QA611B 1/4" & 1/8" COLLETS 90° ANGLE HEAD AIR DIE GRINDER

Head height : 73mm
Free speed : 19000 RPM
Rated power : 0.3 HP
Net weight : 0.51kg

- Safety lever throttle



M7-QA0115B (1/4" & 1/8" COLLETS) AIR DIE GRINDER KIT

Free speed : 25000 RPM
Rated power : 0.3 HP

- Metal front cap

Kit contains :

- 1pc die grinder (M7-QA111B)
- 1pc 1/8" collet
- 1pc 1/4" collet
- 2pcs spanner wrench
- 5pcs 1/8" shank mounted point
- 5pcs 1/4" shank mounted point
- 1pc plug



M7-QA632A 6MM & 3MM COLLETS M7-QA632B 1/4" & 1/8" COLLETS 97° ANGLE HEAD AIR DIE GRINDER

Head height : 100mm
Free speed : 22000 rpm
Net weight : 0.5kg

- Straight drive air motor in head with no gears to wear
- Safety lever throttle



M7-QA412A 3MM COLLET M7-QA412B 1/8" COLLET MICRO AIR DIE GRINDER

Free speed : 60000 RPM
Net weight : 0.24kg

- Roll throttle



AIR ENGRAVING PEN M7-QA511

Blows per minute : 13000 BPM
Net weight : 0.23kg

- Roll throttle



Part No.	Collet Size		Free Speed	Blows Per Minute	Air Requirement			Overall Length	Hose Length	Rated Power	Net Weight	Sound Pressure	Vibration Level
	mm	inch	RPM	BPM	CFM	PSI	Inlet	mm		HP	kg	dBa	m/s ²
M7-QA611B	-	1/4" & 1/8"	19000	-	10.0	90	1/4"	160	-	0.3	0.51	74.4	1.7
M7-QA632A	6 & 3	-	22000	-	12.3	90	1/4"	177	-	0.4	0.50	75.0	2.5
M7-QA632B	-	1/4" & 1/8"	22000	-	12.3	90	1/4"	177	-	0.4	0.50	75.0	2.5
M7-QA412A	3	-	60000	-	2.7	90	1/4"	170	1500	-	0.24	70.0	0.5
M7-QA412B	-	1/8"	60000	-	2.7	90	1/4"	170	1500	-	0.24	70.0	0.5
M7-QA511	-	-	-	13000	1.0	90	1/4"	140	1420	-	0.23	78.0	0.6
Part No.	Description												
M7-QA0115B	Air Die Grinder Kit, 15pc, 25000rpm, 155mm Long, 1/8" & 1/4" Collets												
M7A-313P35A1	3mm Collet To Suit Die Grinders (Except M7-QA412)												
M7A-313P35A2	6mm Collet To Suit Die Grinders (Except M7-QA412)												
M7A-313P35B1	1/8" Collet To Suit Die Grinders (Except M7-QA412)												
M7A-313P35B2	1/4" Collet To Suit Die Grinders (Except M7-QA412)												



M7-QA651B
MINI PISTOL AIR DIE GRINDER

Collet : 1/4"
 Free speed : 18000 RPM
 Net weight : 0.5kg



M7-QA651N 1/8" & 1/4" COLLETS
MINI PISTOL AIR DIE GRINDER KIT

Free speed : 18000 RPM
 Kit contains :

- 1pc die grinder (M7-QA651B)
- 1pc 1/8" collet
- 1pc 1/4" collet
- 5pcs grinder stones 3mm
- 5pcs grinder stones 6mm
- 1pc 1/4" plug
- 1pc oil box
- 2pcs spanner wrench



Part No.	Collet Size	Free Speed	Air Requirement			Overall Length	Net Weight	Sound Pressure	Vibration Level	
	inch	RPM	CFM	PSI	Inlet	mm	kg	dBA	m/s ²	
M7-QA651B	1/4"	18000	2.7	90	1/4"	127	0.50	74.0	0.3	
Part No.	Description									
M7-QA651N	Air Die Grinder Kit, 16pc, 18000rpm, 127mm Long, 1/8" Collets									

AIR BUFFER

M7-QT102
MINI AIR BUFFER

Free speed : 7500 RPM
 Net weight : 0.41kg

- Lever throttle



M7-QT203 4000RPM FREE SPEED
M7-QT113 2500RPM FREE SPEED
AIR BUFFER

Net weight : 0.80kg

- Quick change 7/16" hex shank tool holder, Includes 3/8" 24UNC thread adaptor
- Safety lever throttle

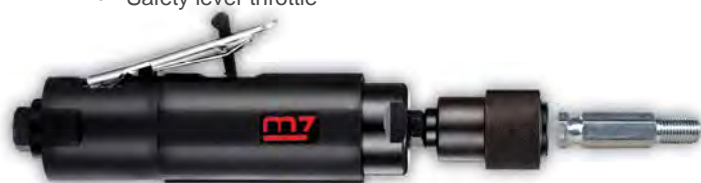

Part No.	Collet Size	Tool Holder	Free Speed	Air Requirement			Overall Length	Motor	Net Weight	Sound Pressure	Vibration Level
	mm	inch	RPM	CFM	PSI	Inlet	mm	hp	kg	dBA	m/s ²
M7-QT102	6	-	7500	3.0	90	1/4"	140	0.3	0.41	77.0	1.3
M7-QT203	-	7/16"	4000	10.6	90	1/4"	250	0.5	0.80	75.0	0.87
M7-QT113	-	7/16"	2500	10.6	90	1/4"	250	0.5	0.80	75.0	0.87





AIR DRILLS

M7-QE831 3/8" AIR REVERSIBLE DRILL KEYLESS CHUCK

Free speed : 1800 RPM
Net weight : 1.1kg

- Quiet operation



M7-QE833 3/8" AIR REVERSIBLE DRILL KEYED CHUCK

Free speed : 1800 RPM
Net weight : 1.1kg

- Quiet operation



M7-QE841 1/2" AIR REVERSIBLE DRILL KEYLESS CHUCK

Free speed : 800 RPM
Net weight : 1.7kg

- Quiet operation



M7-QE843 1/2" AIR REVERSIBLE DRILL KEYED CHUCK

Free speed : 800 RPM
Net weight : 1.8kg

- Quiet operation



M7-QE441 1/2" AIR REVERSIBLE DRILL KEYLESS CHUCK

Free speed : 1100 RPM
Net weight : 1.58kg



M7-QE443 1/2" AIR REVERSIBLE DRILL KEYED CHUCK

Free speed : 1100 RPM
Net weight : 1.73kg



M7-QE633 3/8" 90° ANGLE REVERSIBLE AIR DRILL

Head Height: 110mm
Free speed : 1600 RPM
Net weight : 1.1kg



M7-QE933 3/8" AIR STRAIGHT DRILL

Free speed : 2600 RPM
Net weight : 0.9kg



Part No.	Chuck Size	Free Speed	Air Requirement			Overall Length	Net Weight	Sound Pressure	Vibration Level
	Inch (mm)		RPM	CFM	PSI				
M7-QE831	3/8" (10)	1800	4.0	90	1/4"	185	1.10	83	0.3
M7-QE833	3/8" (10)	1800	4.0	90	1/4"	185	1.10	83	0.3
M7-QE841	1/2" (13)	800	4.0	90	1/4"	210	1.70	83	0.3
M7-QE843	1/2" (13)	800	4.0	90	1/4"	210	1.80	83	0.3
M7-QE441	1/2" (13)	1100	4.0	90	1/4"	270	1.58	90	3.0
M7-QE443	1/2" (13)	1100	4.0	90	1/4"	270	1.73	90	3.0
M7-QE633	3/8" (10)	1600	3.0	90	1/4"	210 x 110	1.10	72	2.5
M7-QE933	3/8" (10)	2600	3.0	90	1/4"	215	0.90	72	2.5



AIR DRILLS

M7-QE532 3/8" AIR DRILL KEYLESS CHUCK

Free speed : 2800 RPM
Net weight : 1.23kg

- 3 piece planetary gear for extra strength



M7-QE323 1/4" MINI AIR REVERSIBLE DRILL KEYED CHUCK

Free speed : 1600 RPM
Net weight : 0.78kg



M7-QE845 1/2" AIR REVERSIBLE DRILL KEYED CHUCK

Free speed : 500 RPM
Net weight : 1.80kg



Part No.	Chuck Size	Free Speed	Motor	Air Requirement			Overall Length	Net Weight	Sound Pressure	Vibration Level
	Inch (mm)	RPM	hp	CFM	PSI	Inlet	mm	kg	dBA	m/s ²
M7-QE532	3/8" (10)	2800	0.7	4.8	90	1/4"	243	1.23	90	2.0
M7-QE323	1/4" (6.35)	1600	0.38	1.9	90	1/4"	164	0.78	74	1.2
M7-QE845	1/2" (13)	500	0.45	4.0	90	1/4"	210	1.80	83	0.3

AIR SPOT WELD DRILL

M7-QE231 SPOT WELD DRILL

Free speed : 1600 RPM
Net weight : 2.1kg

- Comes with hook



Part No.	Chuck Size	Free Speed	Air Requirement			Overall Length	Net Weight	Sound Pressure	Vibration Level
	Inch (mm)	RPM	CFM	PSI	Inlet	mm	kg	dBA	m/s ²
M7-QE231	5/16" (8)	1600	6	90	1/4"	300	2.1	88.2	0.1

Magnetic Base Drilling Machines

Cutting Tools

Clamps

Engineer's Tools

Sharpening Machines

Metal Cutting Saws

Drilling Machines

Bevelling Machines & Welding Carriages

Punches & Shears

Grinding Machines

Fans & Ventilators

Workshop Storage

M7 Airtools

NPK Airtools

Pneumatic Products



AIR SCREWDRIVERS

M7-RA3011 9.7 - 18.5 in-lb

M7-RA3017 6.2 - 13.2 in-lb

M7-RA3023 3.5 - 8.8 in-lb

M7-RA4008 14.1 - 35.4 in-lb

M7-RA4015 8.8 - 19.4 in-lb

M7-RA4021 8.8 - 13.2 in-lb

M7-RA5005 44.2 - 92.9 in-lb

M7-RA5008 26.5 - 48.6 in-lb

M7-RA5017 13.2 - 23.0 in-lb

TORQUE CONTROL SCREWDRIVER

Shut off type

- Proven by our life-time tester, these items can be operated continuously up to 1.5 million times
- Industrial grade, excellent for long continuous operation on various mass production lines
- Precise machined components, unique internal mechanism design.
- Low noise and vibration rate, high adjustable accuracy up to $\pm 5\%$.
- Pressing to start level, ergonomic design, compact volume, light weight, easy and comfortable to operate.



M7-ZT31 DIGITAL TORQUE TESTER

Measurement range : 0 to 150 kgf-cm²

Accuracy : $\pm 1\%$ reading

- For use with torque control screwdriver
- Peak and tracing mode selection
- Unit selection valid for kgf-cm², Nm and lb-ft
- High/low-limits setting and detection. Colour LEDs indication for pass and fail
- RS232 serial bus connection to a PC for peak data reading transmission
- Packed in plastic case. Handy for carrying and storage



M7-RA801 AIR SCREWDRIVER ADJUSTABLE CLUTCH

Screw capacity : M4

Free speed : 1800 RPM

- Net weight : 1.2kg
- Quiet operation



M7-RA802 AIR SCREWDRIVER ADJUSTABLE CLUTCH

Screw capacity : M6

Free speed : 800 RPM

Net weight : 1.3kg

- Quiet operation



Part No.	Chuck Size	Torque Range			Free Speed	Air Requirement			Overall Length	Net Weight	Sound Pressure	Vibration Level
		Inch (mm)	in-lb	ft-lb		Nm	RPM	CFM				
M7-RA3011	1/4" (6.35)	9.7 - 18.5	-	1.1 - 2.1	1100	7.0	90	1/4"	187	0.42	70	2.0
M7-RA3017	1/4" (6.35)	6.2 - 13.2	-	0.7 - 1.5	1700	7.0	90	1/4"	187	0.42	70	2.0
M7-RA3023	1/4" (6.35)	3.5 - 8.8	-	0.4 - 1.0	2300	7.0	90	1/4"	187	0.42	70	2.0
M7-RA4008	1/4" (6.35)	14.1 - 35.4	-	1.6 - 4.0	800	10.5	90	1/4"	209	0.65	74	2.5
M7-RA4015	1/4" (6.35)	8.8 - 19.4	-	1.0 - 2.2	1500	10.5	90	1/4"	209	0.65	74	2.5
M7-RA4021	1/4" (6.35)	8.8 - 13.2	-	1.0 - 1.7	2100	10.5	90	1/4"	209	0.65	74	2.5
M7-RA5005	1/4" (6.35)	44.2 - 92.9	-	5.0 - 10.5	480	17.5	90	1/4"	240	1.00	75	10
M7-RA5008	1/4" (6.35)	26.5 - 48.6	-	3.0 - 5.5	800	17.5	90	1/4"	240	1.00	75	10
M7-RA5017	1/4" (6.35)	13.2 - 23.0	-	1.5 - 2.6	1700	17.5	90	1/4"	240	1.00	75	10
M7-RA801	1/4" (6.35)	-	3.8 - 10.4	5.0 - 14.0	1800	4.0	90	1/4"	195	1.20	83	4.2
M7-RA802	1/4" (6.35)	-	3.8 - 13.3	5.0 - 18.0	800	4.0	90	1/4"	210	1.30	83	4.2
Part No.	Description											
M7-ZT31	Digital Torque Tester											



M7-RA1142
AIR SCREWDRIVER

Screw capacity : M4
Free speed : 1700 RPM
Net weight : 0.61kg

- Positive adjustable clutch



M7-RA1162
AIR SCREWDRIVER

Screw capacity : M4
Free speed : 600 RPM
Net weight : 0.95kg

- Positive adjustable clutch



M7-RA2161
AIR SCREWDRIVER

Screw capacity : M5
Free speed : 750 RPM
Net weight : 1.0kg

- Positive adjustable clutch



M7-RA505
AIR SCREWDRIVER

Screw capacity : M5
Free speed : 11000 RPM
Net weight : 0.7kg

- Twin dog type clutch



Part No.	Chuck Size	Torque Range		Free Speed	Air Requirement			Overall Length	Net Weight	Sound Pressure	Vibration Level
		ft-lb	Nm		RPM	CFM	PSI				
M7-RA1142	1/4" (6.35)	0.7 - 2.2	1 - 3	1700	5.0	90	1/4"	235	0.61	80.0	2.0
M7-RA1162	1/4" (6.35)	1.5 - 5.9	2 - 8	600	6.0	90	1/4"	265	0.95	90.0	2.2
M7-RA2161	1/4" (6.35)	1.4 - 3.7	2 - 5	750	7.5	90	1/4"	190	1.00	80.0	2.0
M7-RA505	1/4" (6.35)	5 - 45	6 - 61	11000	1.8	90	1/4"	161	0.70	74.0	3.3



M7-RA402
AIR SCREWDRIVER

Screw capacity : M6
Free speed : 2200 RPM
Net weight : 1.12kg
• Positive clutch type



M7-RA811
AIR SCREWDRIVER

Screw capacity : M6
Free speed : 2100 RPM
Net weight : 1.13kg
• Positive clutch type



M7-RA1272
AIR SCREWDRIVER

Screw capacity : M8
Free speed : 8000 RPM
Net weight : 1.06kg
• Twin dog type



M7-RA2272
AIR SCREWDRIVER

Screw capacity : M8
Free speed : 7700 RPM
Net weight : 1.38kg
• Twin dog type



Part No.	Chuck Size		Torque Range		Free Speed	Air Requirement			Overall Length	Net Weight	Sound Pressure	Vibration Level
	Inch (mm)	ft-lb	Nm	RPM	CFM	PSI	Inlet	mm	kg	dBA	m/s ²	
M7-RA402	1/4" (6.35)	5 - 14	6 - 19	2200	3.9	90	1/4"	180	1.12	91.0	2.3	
M7-RA811	1/4" (6.35)	5 - 13	6 - 17	2100	4.0	90	1/4"	210	1.13	83.0	3.7	
M7-RA1272	1/4" (6.35)	44 - 177	60 - 240	8000	7.5	90	1/4"	200	1.06	97.0	5.1	
M7-RA2272	1/4" (6.35)	44 - 177	59 - 240	7700	7.0	90	1/4"	195	1.38	93.0	4.9	

AIR PUNCH & FLANGE TOOLS

M7-PN150
AIR PUNCH & FLANGE TOOL

Punch diameter : 5mm
Punch capacity : 1.6mm (steel)
Net weight : 1.15kg



M7-PN180
AIR PUNCH & FLANGE TOOL

Punch diameter : 8mm
Punch capacity : 1.2mm (steel)
Net weight : 1.15kg



Part No.	Punch Diameter	Capacity	Air Requirement			Overall Length	Net Weight	Sound Pressure	Vibration Level
	mm	mm	CFM	PSI	Inlet	mm	kg	dBA	m/s ²
M7-PN150	5	1.6 (steel)	4	90	1/4"	254	1.15	62	0.1
M7-PN180	8	1.2 (steel)	4	90	1/4"	254	1.15	62	0.1

- Magnetic Base Drilling Machines
- Cutting Tools
- Clamps
- Engineer's Tools
- Sharpening Machines
- Metal Cutting Saws
- Drilling Machines
- Bevelling Machines & Welding Carriages
- Grinding Machines
- Fans & Ventilators
- Workshop Storage
- M7 Airtools
- NPK Airtools
- Pneumatic Products





AIR POLISERS

M7-QP223 75MM MINI AIR PISTOL POLISER

Free speed : 5500 RPM
Net weight : 0.5kg



M7-QP123 75MM AIR PISTOL POLISER

Free speed : 2,100rpm
Net weight : 0.77kg



M7-QP223N 75MM MINI AIR POLISER SET

Contents :

- Air mini polisher (M7-QP223)
- 75mm pad backing pad
- 75mm sponge (medium)
- 75mm sponge (coarse)
- 75mm wool bonnet
- 1/4" coupler
- Spanner wrench



M7-QB0618 75MM AIR SANDER SET

Free speed : 15000 RPM
Net weight : 1.3kg

Contents:

- Air mini polisher (M7-QB625)
- 50mm backing pad (1pc)
- 75mm backing pad (1pc)
- 50mm #80 disc (1pc)
- 50mm #150 disc (2pcs)
- 50mm #300 disc (2pcs)
- 50mm stripping disc (1pc)
- 75mm #80 disc (1pc)
- 75mm #150 disc (2pcs)
- 75mm #300 disc (2pcs)
- 75mm stripping disc (1pc)
- Adaptor
- Spanner
- Oil
- Air regulator (M7A-RA101P46)



Part No.	Pad Diameter	Free Speed	Spindle Size	Air Requirement			Overall Length	Rated Power	Net Weight	Sound Pressure	Vibration Level
				mm	CFM	PSI					
M7-QP223	75 (3")	5500	5/16" - 24	2.2	90	1/4"	130	0.38	0.5	74.0	0.9
M7-QP123	75 (3")	2100	-	3.5	90	1/4"	135	0.4	0.77	74	0.3
M7-QB625	50 - 75 (2" - 3")	15000	-	17.2	90	1/4"	180	0.6	1.3	75.0	2.5
Part No.	Description										
M7-QP223N	M7 75mm Mini Polisher, 6 Piece Set, Pistol Style, 5500 Rpm										
M7-QB0618	M7 90° Sander & Polisher, 18 Piece Set, 15000 Rpm										



AIR PISTOL SANDERS

M7-QP215
75MM, 115MM, 125MM
HIGH SPEED
AIR SANDER

Free speed : 16000 RPM
Net weight : 0.91kg



M7-QP113
75MM AIR PISTOL
SANDER

Free speed : 15,000rpm
Net weight : 0.72kg



M7-QP212
50MM & 75MM
HIGH SPEED
MINI AIR SANDER

Free speed : 18000 RPM
Net weight : 0.5kg



M7-QP212N
75MM HIGH SPEED MINI
AIR SANDER SET

Contents :

- Air high speed sander (M7-QP212)
- 50mm rubber pad (1/4"-20)
- 50mm abrasive #80
- 50mm stripping disc #80
- 50mm stripping disc #150
- 75mm rubber pad (1/4"-20)
- 75mm abrasive #80
- 75mm stripping disc #80
- 75mm stripping disc #150
- 1/4" coupler
- Oil bottle
- Spanner wrench



M7-QP213
75MM DUAL ACTION
MINI AIR SANDER

Free speed : 18000 RPM
Net weight : 0.5kg



M7-QP213N
75MM DUAL ACTION MINI
AIR SANDER SET

Contents :

- Air mini polisher (M7-QP213)
- 50mm pad (5/16"-24) (1pc)
- 75mm pad (5/16"-24) (1pc)
- 50mm sandpaper #180 (10pcs)
- 50mm sandpaper #220 (10pcs)
- 50mm sandpaper #320 (10pcs)
- 75mm sandpaper #180 (10pcs)
- 75mm sandpaper #220 (10pcs)
- 75mm sandpaper #320 (10pcs)
- 1/4" coupler (1pc)
- Oil bottle (1pc)
- Spanner wrench (2pcs)



Part No.	Pad Diameter	Free Speed	Spindle Size	Air Requirement			Overall Length	Rated Power	Net Weight	Sound Pressure	Vibration Level
	mm (Inch)			RPM	CFM	PSI					
M7-QP215	75, 115, 125 (3", 4-1/2", 5")	16000	-	6.50	90	1/4"	160	0.80	1.20	60.0	1.8
M7-QP113	75 (3")	15000	2.5	3.5	90	1/4"	127	0.4	0.72	74	0.3
M7-QP212	50, 75 (2", 3")	18000	1/4" - 20	2.1	90	1/4"	107	0.38	0.5	73.0	0.9
M7-QP213	75 (3")	18000	5/16" - 24	2.1	90	1/4"	117	0.38	0.5	76.0	1.2
Part No.	Description										
M7-QP212N	M7 50mm And 75mm Mini High Speed Sander, 10 Piece Set, Pistol Style, 18000 Rpm										
M7-QP213N	M7 75mm Mini Dual Action Sander, Pistol Style, 10 Piece Set, 18000 Rpm										





NON VACUUM SANDERS

M7-QB49602 150MM / 6" RANDOM ORBITAL AIR SANDER

Orbit : 9.5mm
Free speed : 10000 RPM
Net weight : 0.91kg



M7-QB48111 AIR RANDOM ORBITAL SANDER NON VACUUM 100 x 110MM PAD SIZE (JITTERBUG SANDER)

Orbit : 2.5mm
Net weight : 0.91kg

- Spring cock to help reduce consumables cost
- Elastic mechanism for durability and long lifespan
- Lower body with low centre design



M7-QB55602 150MM / 6" RANDOM ORBITAL AIR SANDER

Orbit : 5mm
Free speed : 10000 RPM
Net weight : 0.68kg



M7-QB42602 150MM / 6"RANDOM ORBITAL AIR SANDER

Orbit : 5mm
Free speed : 10000 RPM
Net weight : 0.85kg



SELF GENERATED VACUUM SANDERS

M7-QB56602 150MM / 6" RANDOM ORBITAL AIR SANDER

Orbit : 5mm
Free speed : 10000 RPM
Net weight : 0.78kg

- Comes complete with hose & bag



M7-QB43902 150MM / 6" RANDOM ORBITAL AIR SANDER

Orbit : 5mm
Free speed : 10000 RPM
Net weight : 1.54kg

- Comes complete with hose & bag



Part No.	Pad Diameter	Free Speed	Air Requirement			Overall Length	Rated Power	Net Weight	Sound Pressure	Vibration Level	Orbit
	mm (Inch)		RPM	CFM	PSI						
M7-QB49602	150 (6")	10000	3.60	90	1/4"	220	0.75	0.91	92.5	3.3	9.5
M7-QB48111	100 x 110 (4" x 4-3/8")	11000	7.0	90	1/4"	130	0.28	0.91	83	1.5	2.5
M7-QB55602	150 (6")	10000	3.0	90	1/4"	157	0.24	0.68	81.6	7.1	5
M7-QB42602	150 (6")	10000	3.85	90	1/4"	166	0.24	0.85	74.4	1.3	5
M7-QB56602	150 (6")	10000	3.0	90	1/4"	210	0.24	0.78	81.6	7.1	5
M7-QB43902	150 (6")	10000	3.85	90	1/4"	221	0.24	1.54	83	1.4	5



CENTRAL VACUUM SANDERS

M7-QB54602 150MM / 6" RANDOM ORBITAL AIR SANDER

- Orbit : 5mm
- Free speed : 10000 RPM
- Net weight : 0.78kg
- Economical model



M7-QB41902 150MM / 6" RANDOM ORBITAL AIR SANDER

- Orbit : 5mm
- Free speed : 10000 rpm
- Net weight : 0.91kg



M7-QB45602 150MM / 6" RANDOM ORBITAL AIR SANDER

- Orbit : 5mm
- Free speed : 10000 RPM
- Net weight : 0.84kg
- Extremely low vibration,
ideal for extended use.



Part No.	Pad Diameter	Free Speed	Orbit	Air Requirement			Overall Length	Rated Power	Net Weight	Sound Pressure	Vibration Level
	mm (Inch)	RPM		mm	CFM	PSI					
M7-QB54602	150 (6")	10000	5	3.0	90	1/4"	210	0.24	0.78	81.6	7.1
M7-QB41902	150 (6")	10000	5	3.85	90	1/4"	206	0.24	0.91	81.5	0.8
M7-QB45602	150 (6")	10000	5	3.85	90	1/4"	193	0.24	0.84	81.6	2.2

Magnetic Base Drilling Machines

Cutting Tools

Clamps

Engineer's Tools

Sharpening Machines

Metal Cutting Saws

Drilling Machines

Bevelling Machines & Welding Carriages

Punches & Shears

Grinding Machines

Fans & Ventilators

Workshop Storage

M7 Airtools

NPK Airtools

Pneumatic Products





M7-QP317
178MM AIR ANGLE POLISHER

Free speed : 2500 RPM
Spindle : 5/8" UNC
Net weight : 2.04kg



M7-QP307M
178MM AIR ANGLE SANDER

Free speed : 4500 RPM
Spindle : M14
Net weight : 2.04kg



M7-QP327
178MM AIR ANGLE POLISHER

Free speed : 2500 RPM
Net weight : 2.04kg



M7A-QB317P48
BACKING PAD

178mm to suit M7-QP307M
Spindle : M14



M7A-QB9507
TIE ON LAMBSWOOL BONNET

To suit 178mm polisher
M7-QP317M



M7A-QB9517
VELCRO LAMBSWOOL BONNET

To suit 178mm polisher
M7-QP317M



M7A-QB9337M
VELCRO PAD

To suit 178mm M7-QP307M
Spindle : M14



Part No.	Pad Diameter	Free Speed	Air Requirement			Overall Length	Rated Power	Net Weight	Sound Pressure	Vibration Level
			CFM	PSI	Inlet					
	mm (Inch)	RPM				mm	HP	kg	dBA	m/s ²
M7-QP317	178 (7")	2500	6.0	90	1/4"	406	0.4	2.04	84	2.5
M7-QP307M	178 (7")	4500	6.0	90	1/4"	406	0.4	2.04	84	2.5
M7-QP327	178 (7")	2500	6.0	90	1/4"	406	0.4	2.04	84	2.5
Part No.	Description									
M7A-QB317P48	Backing Pad, 178mm To Suit M7-QP07 Sander									
M7A-QB9507	M7 Tie On Lambswool Bonnet, 178mm									
M7A-QB9517	M7 Velcro Lambswool Bonnet, 178mm									
M7A-QB9337M	M7 Velcro Pad For 178mm Sanders									



CENTRAL VACUUM SANDERS

M7-QB57602 150MM / 6" RANDOM ORBITAL AIR SANDER

Free speed : 10000 RPM
Net weight : 1.2kg

- 2 handed sander
- Robust aluminum alloy body housing encased with composite materials
- Minimises cold feeling during long time usage
- Long grip reduces fatigue
- Adjustable speed switch



M7-QB57642 150MM / 6" RANDOM ORBITAL AIR SANDER

Free speed : 900 RPM
Net weight : 1.6kg

- 2 handed sander
- Gear transmission for quicker hard sanding, saving time and longer lifespan
- Robust aluminum alloy body housing encased with composite materials
- Minimises cold feeling during long time usage
- Long grip reduces fatigue
- Adjustable speed switch



Part No.	Pad Diameter	Free Speed	Air Requirement			Overall Length	Rated Power	Net Weight	Sound Pressure	Vibration Level	Orbit
	mm (Inch)		RPM	CFM	PSI						
M7-QB57602	150 (6")	10000	3.1	90	1/4"	240	0.4	1.2	80.0	1.3	5
M7-QB57642	150 (6")	900	3.1	90	1/4"	240	0.4	1.6	82.0	2.5	5

Magnetic Base Drilling Machines

Cutting Tools

Clamps

Engineer's Tools

Sharpening Machines

Metal Cutting Saws

Drilling Machines

Bevelling Machines & Welding Carriages

Punches & Shears

Grinding Machines

Fans & Ventilators

Workshop Storage

M7 Airtools

NPK Airtools

Pneumatic Products



NON VACUUM SANDERS

M7-QB58602

150MM / 6" RANDOM ORBITAL AIR SANDER

Free speed : 10000 RPM

Net weight : 1.2kg

- 2 handed sander
- Robust aluminium alloy body housing encased with composite materials
- Minimises cold feeling during long time usage
- Long grip reduces fatigue
- Adjustable speed switch



M7-QB58642

150MM / 6" RANDOM ORBITAL AIR SANDER

Free speed : 900 RPM

Net weight : 1.6kg

- 2 handed sander
- Gear transmission for quicker hard sanding, saving time and longer lifespan
- Robust aluminium alloy body housing encased with composite materials
- Minimises cold feeling during long time usage
- Long grip reduces fatigue
- Adjustable speed switch



M7-QB46612

150MM / 6" RANDOM ORBITAL AIR SANDER

Orbit : 2.5mm

Free speed : 10000 RPM

Net weight : 0.79kg

- Extremely low vibration, ideal for extended use.



M7-QB48211

AIR SANDER 64 X 110MM PAD SIZE (JITTERBUG SANDER)

Free speed : 2100 RPM

Net weight : 2.8kg



Part No.	Pad Diameter	Free Speed	Air Requirement			Overall Length	Rated Power	Net Weight	Sound Pressure	Vibration Level	Orbit
	mm (Inch)		RPM	CFM	PSI						
M7-QB58602	150 (6")	10000	3.1	90	1/4"	240	0.4	1.2	80.0	1.3	5
M7-QB58642	150 (6")	900	3.1	90	1/4"	240	0.4	1.6	82.0	2.5	5
M7-QB46612	150 (6")	10000	3.85	90	1/4"	166	0.24	0.79	80.1	2.2	2.5
M7-QB48211	64 x 110	2100	5.0	90	1/4"	444	0.24	2.8	-	2.8	-



SELF GENERATED VACUUM SANDERS

M7-QB59602 150MM / 6" RANDOM ORBITAL AIR SANDER

Free speed : 10000 RPM

Net weight : 1.2kg

- 2 handed sander
- Robust aluminum alloy body housing encased with composite materials
- Minimises cold feeling during long time usage
- Long grip reduces fatigue
- Adjustable speed switch



M7-QB59642 150MM / 6" RANDOM ORBITAL AIR SANDER

Free speed : 900 RPM

Net weight : 1.6kg

- 2 handed sander
- Gear transmission for quicker hard sanding, saving time and longer lifespan
- Robust aluminum alloy body housing encased with composite materials
- Minimises cold feeling during long time usage
- Long grip reduces fatigue
- Adjustable speed switch



Part No.	Pad Diameter	Free Speed	Air Requirement			Overall Length	Rated Power	Net Weight	Sound Pressure	Vibration Level	Orbit
	mm (Inch)		RPM	CFM	PSI						
M7-QB59602	150 (6")	10000	3.1	90	1/4"	240	0.4	1.2	80.0	1.3	5
M7-QB59642	150 (6")	900	3.1	90	1/4"	240	0.4	1.6	82.0	2.5	5

Magnetic Base Drilling Machines

Cutting Tools

Clamps

Engineer's Tools

Sharpening Machines

Metal Cutting Saws

Drilling Machines

Bevelling Machines & Welding Carriages

Punches & Shears

Grinding Machines

Fans & Ventilators

Workshop Storage

M7 Airtools

NPK Airtools

Pneumatic Products



CONSUMABLES

M7A-QB9403 ROUGHING SPONGE

75mm to suit M7-QP123
Pistol Polisher



M7A-QB9413 MEDIUM SPONGE

75mm to suit M7-QP123
Pistol Polisher



M7A-QB9326 6 HOLE M7A-QB9327 15 HOLE VELCRO PAD

To suit 150mm sanders



Part No.	Diameter	Type	To Suit
M7A-QB9302	50mm	Velcro Pad	M7-QP212 & M7-QP213
M7A-QB922	50mm	Roll On Disc Backing Pad	M7-QP212 & M7-QP0618
M7A-QB923	75mm	Roll On Disc Backing Pad	M7-QP212 & M7-QP0618
M7A-QB9403	75mm	Roughing Sponge	M7-QP123
M7A-QB9413	75mm	Medium Sponge	M7-QP123
M7A-QB9305	125mm	Velcro Pad	125mm Random Orbital Sanders 5/16"-24 Male Thread
M7A-QB9315	125mm	Velcro Pad	125mm Random Orbital Sanders 5/16"-24 Male Thread, 6 Hole
M7A-QB9345	125mm	Vinyl Backing Pad	125mm Random Orbital Sanders 5/16"-24 Male Thread
M7A-QB9355	125mm	Vinyl Backing Pad	125mm Random Orbital Sanders 5/16"-24 Male Thread, 6 Hole
M7A-QB9366	125mm	Vinyl Backing Pad	125mm Random Orbital Sanders 5/16"-24 Male Thread, 15 Hole
M7A-QB9326	150mm	Velcro Pad	150mm Random Orbital Sanders, 6 Hole
M7A-QB9327	150mm	Velcro Pad	150mm Random Orbital Sanders, 15 Hole
M7A-QB9306	150mm	Velcro Pad	150mm Random Orbital Sanders 5/16"-24 Male Thread
M7A-QB9316	150mm	Velcro Pad	150mm Random Orbital Sanders 5/16"-24 Male Thread, 6 Hole
M7A-QB9356	150mm	Vinyl Backing Pad	150mm Random Orbital Sanders 5/16"-24 Male Thread, 6 Hole
M7A-QB9307	150mm	Vinyl Backing Pad	150mm Random Orbital Sanders 5/16"-24 Male Thread



AIR BELT SANDERS

M7-QB321 AIR BELT SANDER 10 x 330MM

Free speed : 16000 RPM
Net weight : 0.95kg



M7-QB322 AIR BELT SANDER 20 x 520MM

Free speed : 16000 RPM
Net weight : 1.40kg



M7P-QB322P01C RUBBER PULLEY

Optional accessory for
use with M7-QB322



M7-QB324 AIR BELT SANDER 12.7 x 610MM

Free speed : 16000 RPM
Net weight : 1.10g



M7-QB313 AIR BELT SANDER 30 x 540MM

Free speed : 13000 RPM
Net weight : 2.4kg



Part No.	Belt Size mm (Inch)	Free Speed RPM	Air Requirement			Overall Length mm	Net Weight kg	Sound Pressure dBA	Vibration Level m/s ²
			CFM	PSI	Inlet				
M7-QB321	10 x 330 (3/8" x 13")	16000	4	90	1/4"	320	0.95	88	1.0
M7-QB322	20 x 520 (3/4" x 19")	16000	4	90	1/4"	430	1.40	88	1.3
M7-QB324	12.7 x 610 (1/2" x 24")	16000	4	90	1/4"	455	1.10	88	1.1
M7-QB313	30 x 540 (1-3/16" x 21-1/4")	13000	10	90	1/4"	390	2.40	81	1.2
Part No.	Description								
M7P-QB322P01C	Rubber Pulley For Use With M7-QB322								

AIR FLUX CHIPPER

M7-SN1032 AIR FLUX CHIPPER

Blows per minute : 4000 BPM
Shank size : Square 13mm (0.510")
Net weight : 1.33kg



● M7A-SN1032P18 CHISEL - CHIPPER TIP

To suit M7-SN1032

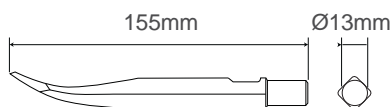

Part No.	Shank Size Inch (mm)	Blows Per Minute BPM	Air Requirement			Overall Length mm	Net Weight kg	Sound Pressure dBA	Vibration Level m/s ²
			CFM	PSI	Inlet				
M7-SN1032	13.0 (0.510)	4000	4.23	90	1/4"	290	1.33	91.00	14.50
Part No.	Description								
M7A-SN1032P18	13mm Round Chipper Tip Chisel To Suit Air Flux Chipper, M7-SN1032								

**M7-QB325N**
BELT SANDER MULTI - ARM KIT

Free speed : 16000 RPM

• 5 x extension bars
Included belt sizes :

- 10 x 330mm
- 3 x 330mm
- 6 x 330mm
- 20 x 330mm
- 20 x 520mm

- Adjustable belt speed control regulator
- Non-woven abraivise belt available
- Ergonomic design for comfortable operation



Part No.	Free Speed	Air Requirement			Overall Length	Net Weight	Sound Pressure	Vibration Level
	RPM	CFM	PSI	Inlet	mm	kg	dBA	m/s ²
M7-QB325	16000	4.0	90	1/4"	320	0.95	90	1.0
Part No.	Description							
M7-QB325N	Belt Sander Multi - Arm Kit							



AIR NEEDLE SCALERS

M7-SN2110 AIR PISTOL NEEDLE SCALER

Blows per minute : 3700 BPM
Net weight : 2.8kg
• Needle size : 3 x 180mm (19 per set)



M7-SN1288 AIR NEEDLE SCALER

Blows per minute : 5500 BPM
Net weight : 1.3kg
• Needle size : 3 x 123mm (12 per set)
• Great compact design



M7-SN1268 AIR NEEDLE SCALER

Blows per minute : 4600 BPM
Net weight : 2.8kg
• Needle size : 3 x 180mm (19 per set)



M7-SN1368 AIR NEEDLE SCALER

Blows per minute : 3400 BPM
Net weight : 2.69kg
• Quick release lock button



M7A-SN1288CHKIT AIR CHISEL KIT

- To suit Air Needle Scaler M7-SN1288
- Includes chisel, nut and spring



M7A-SN1288P15 CHISEL

- 114mm length
- Replacement chisel for use with M7A-SN1288CHKIT Air Chisel Kit



Part No.	Stroke Length	Blows Per Minute	Air Requirement			Overall Length	Net Weight	Sound Pressure	Vibration Level
	mm		CFM	PSI	Inlet				
M7-SN2110	33	3700	15.0	90	1/4"	330	2.8	97.0	9.70
M7-SN1288	32	5500	3.0	90	1/4"	290	1.3	86.0	7.67
M7-SN1268	28	4600	15.0	90	1/4"	460	2.8	91.0	13.7
M7-SN1368	27	3400	16.0	90	1/4"	432	2.69	91.0	13.70
Part No.	Description								
M7A-2110T18	Needle Set (19) 3mm x 180mm Needles To Suit M7-SN2110								
M7A-2110T18B	Needle Set (19) 2mm x 180mm Needles To Suit M7-SN2110								
M7A-288T12	Needle & Holder Set (12) 3mm x 123mm Needles To Suit M7-SN1288								
M7A-1268T16	Needle Set (12) 3mm x 123mm Needles To Suit M7-SN1288								
M7A-SN1288P15	Chisel, 114mm Length, For Use With M7A-SN1288CHKIT								
M7A-SN1288CHKIT	Chisel Kit, With Nut and Spring, To Suit SN1288 Needle Scaler								

Magnetic Base Drilling Machines

Cutting Tools

Clamps

Engineer's Tools

Sharpening Machines

Metal Cutting Saws

Drilling Machines

Bevelling Machines & Welding Carriages

Punches & Shears

Grinding Machines

Fans & Ventilators

Workshop Storage

M7 Airtools

NPK Airtools

Pneumatic Products





AIR NEEDLE SCALERS

M7-SN2124 AIR PISTOL NEEDLE SCALER

Blows per minute : 4000 BPM
 Net weight : 3.6kg
 Needle size : 3 x 180mm (24 per set)

- Springless design for superior performance



M7-SN2128 AIR PISTOL NEEDLE SCALER

Blows per minute : 3500 BPM
 Net weight : 2.8kg
 Needle size : 3 x 180mm (28 per set)

- Springless design for superior performance



Part No.	Stroke Length	Blows Per Minute	Air Requirement			Overall Length	Net Weight	Sound Pressure	Vibration Level
	mm		CFM	PSI	Inlet				
M7-SN2124	27	4000	7.4	90	1/4"	350	3.6	99.0	14.8
M7-SN2128	28	3500	7.4	90	1/4"	335	2.8	100.0	8.1
Part No.	Description								
M7A-SN2124T05A	M7 Needle Set (23 x NC3x180) 3mm x 180 Needles To Suit M7-SN2124								
M7A-SN2128T05A	M7 Needle Set (28 x NC3x180) 3mm x 180 Needles To Suit M7-SN2128								
M7A-SN2124T05B	M7 Needle Set (53 x NC2x180) 2mm x 180 Needles To Suit M7-SN2124								
M7A-SN2128T05B	M7 Needle Set (14 x NC4x180) 4mm x 180 Needles To Suit M7-SN2128								
M7A-SN2128T05C	M7 Needle Set (66 x NC2x180) 2mm x 180 Needles To Suit M7-SN2128								

Magnetic Base Drilling Machines

Cutting Tools

Clamps

Engineer's Tools

Sharpening Machines

Metal Cutting Saws

Drilling Machines

Bevelling Machines & Welding Carriages

Punches & Shears

Grinding Machines

Fans & Ventilators

Workshop Storage

M7 Airtools

NPK Airtools

Pneumatic Products





AIR HAMMERS

● M7-SC211C AIR HAMMER ROUND SHANK

- Shank size : Round 10.2mm (0.401")
Blows per minute : 3200 BPM
Net weight : 1.7kg
- Comes with 5 pce chisel kit (M7A-SC415)



● M7-SC212C ROUND SHANK ◆ M7-SC222C HEX SHANK AIR HAMMER

- Shank size : Round 10.2mm (0.401")
Shank size : Hex 10.0mm (0.393")
Blows per minute : 2200 BPM
Net weight : 2kg
- Comes with 5 pce chisel kit (M7A-SC415 / M7A-SC425)



● M7-SC0517C AIR HAMMER ROUND SHANK SET

- Blows per minute : 3200 BPM
Contents:
- 1pc Air hammer (M7-SC211C)
 - 5pcs Chisel kit
 - 1pc Spring retainer



M7A-SC2B QUICK CHANGE RETAINER

Replaces retainer spring for quick change of chisels
Suits : M7-SC211C, M7-SC212C, M7-SC222C



CHISELS

Length : 175mm



Part No.	Shank	Description	Model To Suit
M7A-SC4101	●	Flat Chisel	M7-SC211C, M7-SC212C
M7A-SC4102	●	Cutting Chisel	M7-SC211C, M7-SC212C
M7A-SC4103	●	Tapered Chisel	M7-SC211C, M7-SC212C
M7A-SC4104	●	Ripping Chisel	M7-SC211C, M7-SC212C
M7A-SC4105	●	Tail Pipe Chisel	M7-SC211C, M7-SC212C
M7A-SC4201	◆	Flat Chisel	M7-SC222C
M7A-SC4202	◆	Cutting Chisel	M7-SC222C
M7A-SC4203	◆	Tapered Chisel	M7-SC222C
M7A-SC4204	◆	Ripping Chisel	M7-SC222C
M7A-SC4205	◆	Tail Pipe Chisel	M7-SC222C
Part No.	Description		
M7A-SC415	Chisel Set, Round Shank, 5pcs, To Suit M7-SC211C, M7-SC212C		
M7A-SC425	Chisel Set, Hex Shank, 5pcs, To Suit M7-SC222C		

Part No.	Shank	Shank Size	Blows Per Minute	Air Requirement			Overall Length	Net Weight	Sound Pressure	Vibration Level
		mm (Inch)		CFM	PSI	Inlet				
M7-SC211C	●	10.2 (0.401")	3200	4.0	90	1/4"	175	1.70	98.00	12.30
M7-SC212C	●	10.2 (0.401")	2200	4.0	90	1/4"	225	2.00	94.70	13.20
M7-SC222C	◆	10.0 (0.393")	2200	4.0	90	1/4"	225	2.00	94.70	13.20
Part No.	Description									
M7-SC0517C	Air Hammer Kit, With 5pcs Round Shank Chisel Set, 3200 BPM, 175mm Long									
M7A-SC2B	Quick Change Retainer To Suit Air Hammers, M7-SC211C, M7-SC212C, M7-SC222C									



AIR HAMMERS

- **M7A-SC33C** ROUND SHANK
 - **M7A-SC34C** HEX SHANK
- NEEDLE SCALE ADAPTOR**

- Converts air hammer to a air needle scaler
- 3mm x 180mm scalers

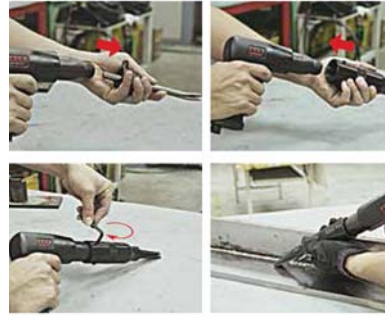

Part No.	Description
M7A-SC33C	Needle scale adaptor, round shank, for use with M7-SC211C
M7A-SC34C	Needle scale adaptor, hex shank, for use with M7-SC221C, M7-SC222C

Magnetic Base Drilling Machines

Cutting Tools

Clamps

Engineer's Tools

Sharpening Machines

Metal Cutting Saws

Drilling Machines

Bevelling Machines & Welding Carriages

Punches & Shears

Grinding Machines

Fans & Ventilators

Workshop Storage

M7 Airtools

NPK Airtools

Pneumatic Products





◆ M7-SN3222 AIR CHIPPING HAMMER HEX SHANK

Shank size : 15mm (0.58")
Blows per minute : 2300BPM
Net weight : 7.8kg

- Forged steel body provides industrial level quality and durability
- Straight forward design for easy maintenance and repair
- Chisel not included



◆ M7-SN3223 AIR CHIPPING HAMMER HEX SHANK

Shank size : 15mm (0.58")
Blows per minute : 1900BPM
Net weight : 8.5kg

- Forged steel body provides industrial level quality and durability
- Straight forward design for easy maintenance and repair
- Chisel not included



◆ M7-SN3224 AIR CHIPPING HAMMER HEX SHANK

Shank size : 15mm (0.58")
Blows per minute : 1700BPM
Net weight : 8.8kg

- Forged steel construction body provides industrial level quality and durability
- Straight forward design for easy maintenance and repair
- Chisel not included



◆ M7A-SN9201 CHISEL - BLADE TIP

To suit M7-SN3222, M7-SN3223 & M7-SN3224

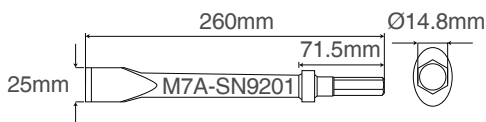

◆ M7A-SN9203 CHISEL - POINT TIP

To suit M7-SN3222, M7-SN3223 & M7-SN3224

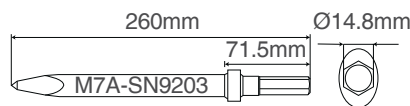

Part No.	Shank	Shank Size	Blows Per Minute	Air Requirement			Stroke Length	Piston Diameter	Piston Length	Overall Length	Net Weight	Sound Pressure	Vibration Level
		mm (Inch)		CFM	PSI	Inlet							
M7-SN3222	◆	15.0 (0.58")	2300	22.0	90	3/8"	78	28.7	66.8	373	7.80	114.39	9.41
M7-SN3223	◆	15.0 (0.58")	1900	24.0	90	3/8"	119	28.7	73.6	419	8.50	113.35	4.85
M7-SN3224	◆	15.0 (0.58")	1700	24.0	90	3/8"	142	28.7	76.0	445	8.80	114.16	6.22
Part No.	Description												
M7A-SN9201	14.8mm Hex Chisel Blade Tip To Suit Air Hammers, M7-SN3222, M7-SN3223 & M7-SN3224												
M7A-SN9203	14.8mm Hex Chisel Point Tip To Suit Air Hammers, M7-SN3222, M7-SN3223 & M7-SN3224												

Magnetic Base Drilling Machines

Cutting Tools

Clamps

Engineer's Tools

Sharpening Machines

Metal Cutting Saws

Drilling Machines

Bevelling Machines & Welding Carriages

Punches & Shears

Grinding Machines

Fans & Ventilators

Workshop Storage

M7 Airtools

NPK Airtools

Pneumatic Products





AIR GREASE GUNS

M7-SG500 AIR GREASE GUN - MANUAL PULSE TYPE



Capacity : 450g cartridge or 500g bulk
Net weight : 1.46kg

- Bulk & cartridge type

M7-SG501 AIR GREASE GUN - CONTINUOUS FULLY AUTOMATIC TYPE



Capacity : 450g cartridge or 500g bulk
Working pressure : 40 - 90psi
Output volume : 288ml/min
Net weight : 1.6kg

- Bulk & cartridge type
- Heavy duty cast aluminium body for maximum durability
- Includes 305mm flexible hose

Part No.	Air Inlet	Stroke Length	Proof Pressure	Cartridge Size	Net Weight	Sound Pressure	Vibration Level
	inch	mm	kgf/cm ²	gram	kg	dBA	m/s ²
M7-SG500	1/4"	2.8 - 8.4	10.5	450	1.46	80.2	0.7
M7-SG501	1/4"	2.8 - 8.4	10.5	450	1.60	74.0	2.0
Part No.	Description						
M7A-SG212	300mm Flexible Tube, Suit Grease Gun						

AUTOMOTIVE TOOLS

M7-QK111 AIR WINDSHIELD REMOVER, PADS AVAILABLE FOR USE AS SANDER

Net weight : 1.1kg

- The rear exhaust and extended muffler tube reduce the noise and air pollution efficiently
- Lower vibration minimises the user's fatigue and enables longer operation
- Lower wear rate of components prolong the durability of the tool
- Blade can be mounted in 12 different ways
- Comes complete with M7A-QK11150 blade



AIR WINDSHIELD REMOVER BLADES AND SANDER PAD

- For use with M7-QK111 air windshield remover



M7A-QK111P51
Blade length : 18mm

M7A-QK111P52
Blade length : 36mm

M7A-QK111P53
Blade length : 63mm

M7A-QK111P54
Blade length : 57mm

M7A-QK111P50
Blade length : 57mm

M7A-QB9320
Triangular sander pad

Part No.	Oscillation	Capacity	Avg. Air Consumption			Overall Length	Max Pressure	Net Weight	Sound Pressure	Vibration Level
			CFM	PSI	Inlet					
M7-QK111	20000	-	6.0	-	1/4"	180	-	1.10	75	3.9
Part No.	Description									
M7A-QK111P51	Blade Length 18mm To Suit M7-QK111									
M7A-QK111P52	Blade Length 36mm To Suit M7-QK111									
M7A-QK111P53	Blade Length 63mm To Suit M7-QK111									
M7A-QK111P54	Blade Length 57mm To Suit M7-QK111									
M7A-QK111P50	Blade Length 57mm To Suit M7-QK111									



M7-QB802 AIR SURFACE CLEANING TOOL

Free speed : 3600 RPM

- Designed for removing vinyl, decals, pinstripes, reflective tape and adhesives quickly and easily in a single operation. Suitable for metal, glass, wood and fibreglass, the Surface Cleaning Tool strips vinyl without damaging paint or harming the underlying surface
- The unique Eraser Wheel is designed with notched "fingers" that grab the edge of the vinyl and peel it from the surface
- Multiple layers of vinyl - old or new - can be removed at one time in hot or cold weather. Vibration free and smooth operation for easy handling and low fatigue
- There is no heat damage or smearing of adhesive on the substrate



AIR SURFACE CLEANING TOOL CONSUMABLES AND ACCESSORIES

- For use with M7-QB802 air surface cleaning tool



M7A-QB9414
Rubber Eraser Wheel



M7A-QB9415
Clean And Strip Wheel



M7A-QB9411
Coarse Wire Wheel



M7A-QB9412
Fine Wire Wheel



M7A-QB9400
Hub For Wire Wheels



M7A-QB9401
Coarse Wire Wheel And Hub

M7-QB812 AIR ERASER



M7A-QB812P34 ERASER WHEEL

Ø 90 x 15mm
Optional accessory for use with M7-QB812



Wheels size : Ø 90 x 15mm
Free speed : 3400 RPM

- Designed for removing vinyl, decals, pinstripes, reflective tape and adhesives quickly and easily in a single operation. Suitable for metal, glass, wood and fibreglass, the Air Eraser strips vinyl without damaging paint or harming the underlying surface
- Small size allows access to confined spaces



M7-QB0808 AIR SURFACE CLEANING TOOL KIT

Contents :

- Air surface cleaning tool (M7-QB802)
- Rubber wheel (M7A-QB9414)
- Hub for wire wheels
- Coarse wire wheel (M7A-QB9411)
- Fine wire wheel (M7A-QB9412)
- Clean and strip wheel (M7A-QB9415)



Part No.	Free Speed	Avg. Air Consumption			Overall Length	Rated Power	Net Weight	Sound Pressure	Vibration Level
	RPM	CFM	PSI	Inlet	mm	HP	kg	dBA	m/s ²
M7-QB802	3600	10.6	90	1/4"	200	0.7	1.2	86	0.3
M7-QB812	4000	10.0	90	1/4"	225	0.5	0.8	75	0.87
Part No.	Description								
M7-QB0808	Air Surface Cleaning Tool Kit								
M7A-QB9414	Replacement Rubber Eraser Wheel For Use With Air Surface Cleaning Tool M7-QB802								
M7A-QB812P34	Eraser Wheel To Suit M7-QB812, Ø90 x 15mm								
M7A-QB9415	Clean And Strip Wheel For Use With Air Surface Cleaning Tool M7-QB802								
M7A-QB9411	Coarse Wire Wheel For Use With Air Surface Cleaning Tool M7-QB802								
M7A-QB9412	Fine Wheel For Use With Air Surface Cleaning Tool M7-QB802								
M7A-QB9400	Hub For Wire Wheel, For Use With Air Surface Cleaning Tool M7-QB802								
M7A-QB9401	Coarse Wire Wheel And Hub For Use With Air Surface Cleaning Tool M7-QB802								

**M7-QB802TA**
AIR SURFACE CLEANING TOOL

Free speed : 4000 RPM

- Designed for removing vinyl, decals, pinstripes, reflective tape and adhesives quickly and easily in a single operation. Suitable for metal, glass, wood and fibreglass, the Surface Cleaning Tool strips vinyl without damaging paint or harming the underlying surface
- The unique Eraser Wheel is designed with notched "fingers" that grab the edge of the vinyl and peel it from the surface
- Multiple layers of vinyl - old or new - can be removed at one time in hot or cold weather. Vibration free and smooth operation for easy handling and low fatigue
- There is no heat damage or smearing of adhesive on the substrate

**M7-QT303**
AIR TYRE BUFFER

Free speed : 22000 RPM

Chuck size : HEX 7/16" (11.1mm)

- Quick change chuck

**M7-QT112T**
AIR TYRE BUFFER

Collet size : 6mm

Free speed : 4000 RPM

Motor : 0.5HP

Net weight : 0.78kg



Part No.	Chuck Size	Free Speed	Avg. Air Consumption			Overall Length	Rated Power	Net Weight	Sound Pressure	Vibration Level
	Inch (mm)	RPM	CFM	PSI	Inlet	mm	HP	kg	dBA	m/s ²
M7-QB802TA	-	4000	5.0	90	1/4"	212	0.5	1.4	85	1.2
M7-QT303	HEX 7/16" (11.1)	22000	5.0	90	1/4"	217	0.5	0.79	85	1.6
M7-QT112T	-	4000	5.0	90	1/4"	212	0.5	1.4	85	1.2



M7-SM0901 MANUAL & PNEUMATIC FLUID EXTRACTOR

Capacity : 9L

- Enables removal of vehicle fluids without requiring to jack up vehicle
- Automatic shut off of extractor unit when extractor tank reaches full capacity



M7-SM0902 PNEUMATIC FLUID EXTRACTOR

Capacity : 9L

- Enables removal of vehicle fluids without requiring to jack up vehicle
- Automatic shut off of extractor unit when extractor tank reaches full capacity



M7-SM0903 MANUAL FLUID EXTRACTOR

Capacity : 9L

- Enables removal of vehicle fluids without requiring to jack up vehicle



M7-SM0502 PNEUMATIC BRAKE EXTRACTOR & REFILL KIT

Capacity : 2L

- Can be used for automatic hydraulic applications such as brake, clutch and power steering systems



Part No.	Air Pressure PSI	Net Weight kg	Capacity L
M7-SM0901	70 - 170	4.7	9.0
M7-SM0902	70 - 170	4.7	9.0
M7-SM0903	70 - 170	4.0	9.0
M7-SM0502	70 - 170	2.5	2.0

M7-ZF01 MECHANICS FENDER COVER

Size : 1050mm x 650mm

Weight : 0.649kg

- Protection from unwanted scratches, dents and dirt
- Magnetic attachment prevents unwanted movement
- Rugged, padded imitation leather and reinforced edges provide a perfect cushioned working area



Part No.	Description
M7-ZF01	Mechanics Fender Cover



**M7-SB201B BAR READ OUT
M7-SB201P PSI READ OUT
DIGITAL TYRE INFLATOR**

- Net Weight : 0.32kg
- PSI readout
 - Clip type nozzle



**M7-SB501
TYRE INFLATOR
SERVICE STATION STYLE**

- Range : 0 - 160 PSI
Hose length : 300mm
- Hold on dual angle nozzle



**M7-SB423
TRUCK TYRE
GAUGE**

- Gauge size : 100mm
Max pressure : 220 PSI
Hose dimensions : 1/4" x 1000mm
- Tyre valve clip nozzle



Part No.	Max Pressure		Avg. Air Consumption			Net Weight	Nozzle Length
	PSI	BAR	CFM	PSI	Inlet		
M7-SB201B	-	11.0	1.41 (at 100PSI)	90	1/4"	0.32	300
M7-SB201P	160	-	1.41 (at 100PSI)	90	1/4"	0.32	300
M7-SB501	160	11.0	-	90	1/4"	1.20	1/4" x 300
M7-SB423	220	15.0	-	90	1/4"	1.14	1/4" x 1000

**M7-SQ0217
AIR POWERED BRAKE CALIPER
WIND-BACK TOOL SET**

17 Piece set



F = Front, R = Rear

No.	Application
0	GM most 2-1/2" diameter pistons
2	Citroën XM, Xantia (F/R); Honda
3	Audi(F); Fiat; Alfa Romeo (F); Ford Fiesta (F); Isuzu (F); Jaguar XJ6, XJ40 (F/R); BMW 318is, 320i, 325TD, 518i, 740i, 850ci, M5 (F); Mercedes Benz 190, 200, 300, 420, 500 series (F); Mitsubishi Colt (F); Toyota Camry (F); Volvo (F); VW Passat, Golf GTI (F)
4	Ford Australia and NZ; Mazda (R); Saab 9000 (R); Toyota; Fiat; Alfa Romeo 164 2.0 (R); Honda Prelude; CRS 16i
5	3/8" adapter
6	Nissan Primera; VW Golf IV
7	Audi 80, 90, V8+100, Coupe E (R); Subaru L+Z (R); Ford; Nissan Bluebird 1.8 Turbo, Silvia Turbo, Primera 2.0iLS/GS/GSX (R); Peugeot; Toyota Celica, Corolla GT, MR2 (R); VW Golf Gti, Jeta Synchro, Jetta Gti 16v, Passat; Citroën; Alfa Romeo; Fiat; Honda; Jaguar; Renault; SAAB; Seat; Lancia
8	GM most 1-7/8" diameter pistons
9	GM most 2-1/8" diameter pistons
A(Z)	Renault R21, Laguna (R)
E	Nissan Maxima; Ford
F(G)	Opel (R)
M	Ford Motors; Mini R68; Mazda 3
N	SAAB; Honda; Alfa Romeo; Audi; VW; Lancia
K	Citroën
K1	Citroën

Part No.	Description
M7-SQ0217	Air Powered Brake Caliper Wind Back Tool Set, 17 Piece



**M7-SK1010
AIR CAULKING GUN**

Capacity : 410g cartridge
Net weight : 1.1kg

- Ergonomic design for comfortable operation



**M7-QM1125
PNEUMATIC CV JOINT BOOTS
FITTING TOOL**

Size range : 1" to 4-3/8" (25 to 110mm)

- Suitable for cars, small vans and light duty commercial vehicles



**M7-SK1131
AIR SAUSAGE CAULKING GUN**

Capacity : 600ml sausage
Net weight : 1.21kg



**M7A-QM901
C.V. BOOT KIT**

Universal repairing kit for auto transmission shaft boot
Includes :

- C.V. Boot
- C.V. Joint grease
- 2x clamps



**M7-SX2101
AIR UPHOLSTERY CLEANER**

Cup capacity : 1.0L
Net weight : 0.78kg



**M7-SX1615
ENGINE CLEANING GUN**

Cup capacity : 1.0L

- Composite body



Part No.	Capacity	Fitting Capacity	Free Speed		Avg. Air Consumption			Overall Length	Max Pressure	Net Weight	Sound Pressure
			RPM	CFM	PSI	Inlet	mm				
M7-SK1010	410g	-	-	1.0	50 - 70	1/4"	305mm	-	1.1	-	
M7-QM1125	-	25 - 110mm (1" - 4-3/8")	-	-	90	1/4"	442	125	3.24	-	
M7-SK1131	600ml	-	-	4.0	60 - 90	1/4"	620mm	-	1.21	-	
M7-SX2101	1.0L	-	5500	2.0	90	1/4"	210 x 110mm	-	0.78	85.0	
M7-SX1615	1.0L	-	-	5.0	90	1/4"	-	170	0.50	-	
Part No.	Description										
M7A-QM901	C.V. Boot Kit										



- Magnetic Base Drilling Machines
- Cutting Tools
- Clamps
- Engineer's Tools
- Sharpening Machines
- Metal Cutting Saws
- Drilling Machines
- Bevelling Machines & Welding Carriages
- Punches & Shears
- Grinding Machines
- Fans & Ventilators
- Workshop Storage
- M7 Airtools
- NPK Airtools
- Pneumatic Products



M7-QK111T AIR KNIFE

Oscillation : 20000 per min
Net weight : 0.92kg



Part No.	Oscillation	Free Speed	Air Requirement			Overall Length	Net Weight	Sound Pressure	Vibration Level
	per minute	RPM	CFM	PSI	Inlet	mm	kg	dBA	m/s ²
M7-QK111T	2000	1900	5.0	90	1/4"	208	0.92	85	3.3

M7-WG202 WONDER GUN

Vacuum level : 7.5mmHg
Net weight : 0.67kg

- Can be used as blow gun or air vacuum gun
- Use for suction of dust, wood chips, metal shavings, glass etc.
- 6 piece set



M7-WG202N WONDER GUN KIT

Vacuum level : 7.5mmHg
Net weight : 0.6kg

- Can be used as blow gun or air vacuum gun
- Use for suction of dust, wood chips, metal shavings, glass etc.
- 8 piece set
- Includes plastic carry case



Part No.	Vacuum Level	Air Requirement			Overall Length	Net Weight	Sound Pressure
	mmHg	CFM	PSI	Inlet	mm	kg	dBA
M7-WG202	7.5	3.36	90	1/4"	145	0.67	92
M7-WG202N	7.5	3.36	90	1/4"	145	0.6	92

Magnetic
Base
Drilling
Machines

Cutting
Tools

Clamps

Engineer's
Tools

Sharpening
Machines

Metal
Cutting
Saws

Drilling
Machines

Bevelling
Machines
& Welding
Carriages

Punches
& Shears

Grinding
Machines

Fans &
Ventilators

Workshop
Storage

M7
Airtools

NPK
Airtools

Pneumatic
Products

AUTOMOTIVE TOOLS

M7-SX3101 GRIT BLASTING GUN

Capacity : 1L
Net weight : 0.57kg

- For removing rust, old paint and ingrained dirt etc.
- Adjustable nozzle
- Hanger hook



M7-SX3103 GRIT BLASTING GUN WITH SUCTION PIPE

Steel pick up length : 600mm
Hose length : 1m
Net weight : 0.44kg

- For removing rust, old paint and ingrained dirt etc.



M7-SX3112 UNDERSEAL GUN

Capacity : 1L
Net weight : 0.22kg

- For applying underseal and stone chip coatings
- Adjustable nozzle
- Hanger hook



M7-SX3201 CLEANING FOAM SPRAY GUN

Capacity : 1.8L
Net weight : 0.22kg

- Includes 2 nozzles
- Adjustable air valve



M7-SX3202 CLEANING GUN - FLEXIBLE HOSE

Capacity : 1L
Net weight : 0.47kg

- Lance with adjustable nozzle with cone
- Suitable for applying degreasant and cleaning adgents



M7-SX3203 CLEANING GUN

Capacity : 1L
Net weight : 0.53kg

- Lance with adjustable nozzle with cone
- Polyethylene tank and tube with adjustable spray / jet nozzle



Part No.	Cup Capacity	Hose Length	Air Requirement			Overall Length	Net Weight	Sound Pressure
	L		CFM	PSI	Inlet			
M7-SX3101	1.0	-	4.3	90	1/4"	280	0.57	85.0
M7-SX3103	-	1000	3.0	90	1/4"	260	0.44	85.0
M7-SX3112	-	-	3.0	90	1/4"	260	0.22	85.0
M7-SX3201	1.8	-	3.6	90	1/4"	400	0.98	65.0
M7-SX3202	1.0	360	1.0	90	1/4"	530	0.47	65.0
M7-SX3203	1.0	300	1.0	90	1/4"	470	0.53	65.0



AIR BRUSH SET

M7-SR1101

0.2mm nozzle bore
7.0 c.c. colour cup capacity
Spray controlled with needle adjustor
Contents:

- Air brush
- Copper cup
- Mix bottle
- PU air hose 4x1850mm
- Pipette
- 1/4" Air adaptor
- Spanner
- Storage bottle



Part No.	Description
M7-SR1101	Air Brush Set, 8 Piece

AIR TOOL ACCESSORIES

M7-ZB812 ANTI VIBRATION FULL FINGER GLOVES

Gel filled palm pad to decrease vibrations



M7-ZB814 ANTI VIBRATION HALF FINGER GLOVES

Gel filled palm pad to decrease vibrations



M7Z-ZC111 HEAVY DUTY TOOL BAG - SMALL

370mm (L) x 250mm (H)
230mm (W)



M7Z-ZC112 HEAVY DUTY TOOL BAG - LARGE

400mm (L) x 220mm (H)
300mm (W)
• Tough rubber base



Part No.	Description
M7-ZB812M	Anti Vibration Full Finger Gloves - Medium
M7-ZB812L	Anti Vibration Full Finger Gloves - Large
M7-ZB812XL	Anti Vibration Full Finger Gloves - Extra Large
M7-ZB812XXL	Anti Vibration Full Finger Gloves - Extra Extra Large
M7-ZB814M	Anti Vibration Half Finger Gloves - Medium
M7-ZB814L	Anti Vibration Half Finger Gloves - Large
M7-ZB814XL	Anti Vibration Half Finger Gloves - Extra Large
M7-ZB814XXL	Anti Vibration Half Finger Gloves - Extra Extra Large
M7Z-ZC111	Heavy Duty Tool Bag - Small
M7Z-ZC112	Heavy Duty Tool Bag - Large

Magnetic
Base
Drilling
Machines

Cutting
Tools

Clamps

Engineer's
Tools

Sharpening
Machines

Metal
Cutting
Saws

Drilling
Machines

Bevelling
Machines
& Welding
Carriages

Punches
& Shears

Grinding
Machines

Fans &
Ventilators

Workshop
Storage

M7
Airtools

NPK
Airtools

Pneumatic
Products



AIR TOOL ACCESSORIES

Spring balancers will always keep the tool in place and easily accessible. The spring balancers will retract when released and tension will be higher the longer the wire is dragged out. The balancer is equipped with an automatic safety drum lock in case of spring failure.

M7-SP101 0.3 - 0.8KG CAPACITY
M7-SP102 0.6 - 1.5KG CAPACITY
M7-SP103 1.0 - 2.0KG CAPACITY
M7-SP104 1.5 - 3.0KG CAPACITY
M7-SP105 3.0 - 5.0KG CAPACITY
SPRING BALANCERS

M7-SP3090 5.0 - 9.0KG CAPACITY
M7-SP3150 9.0 - 15.0KG CAPACITY
M7-SP3220 15.0 - 22.0KG CAPACITY
M7-SP3300 22.0 - 33.0KG CAPACITY
M7-SP3400 30.0 - 40.0KG CAPACITY
M7-SP3500 40.0 - 50.0KG CAPACITY
M7-SP3600 50.0 - 60.0KG CAPACITY
M7-SP3700 60.0 - 70.0KG CAPACITY
SPIRAL SPRING BALANCERS



- Features a sturdy metal casing



Part No.	Capacity	Travel Length	Cable Diameter	Weight
	kg	m	mm	kg
M7-SP101	0.3 - 0.8	1.6	2.5	0.49
M7-SP102	0.6 - 1.5	1.6	2.5	0.52
M7-SP103	1.0 - 2.0	1.6	2.5	0.53
M7-SP104	1.5 - 3.0	1.5	3.2	0.76
M7-SP105	3.0 - 5.0	1.5	3.2	0.81
M7-SP3090	5.0 - 9.0	1.3	4.0	3.60
M7-SP3150	9.0 - 15.0	1.3	4.0	3.60
M7-SP3220	15.0 - 22.0	1.5	4.8	7.70
M7-SP3300	22.0 - 30.0	1.5	4.8	8.30
M7-SP3400	30.0 - 40.0	1.5	4.8	9.70
M7-SP3500	40.0 - 50.0	1.5	4.8	10.10
M7-SP3600	50.0 - 60.0	1.5	4.8	11.10
M7-SP3700	60.0 - 70.0	1.5	4.8	11.40



**M7A-RA101P46
AIR REGULATOR**

- Variable air regulator
- Screws directly into the air inlet of the tool



**M7A-SW1214
MINI LUBRICATOR**

Thread size : 1/4"
Oil capacity : 8 c.c.

- Inline oiler to provide automatic lubrication of the air tool

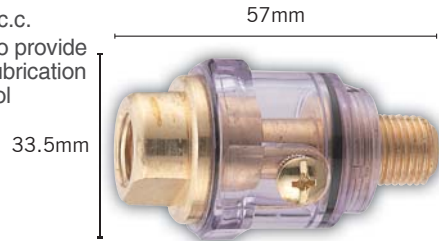

**M7A-QE98L
DOUBLE AXIS BUBBLE
SPIRIT LEVEL GRADIENTER**

- Suitable for use with M7 air drills



**M7-SO1005 500ML
M7-SO1010 1L
M7-SO1050 5L
M7-SO1200 20L DRUM
WITH PROVISION FOR A TAP
AIR TOOL OIL**

- Suitable for use with all air tools



**M7-SG101
AIR TOOL
LUBRICATION KIT**

- 100ml



**M7-SO10T
AIR TOOL
LUBRICATION PACK**

- Pack of 8
- 100ml
- Supplied in cardboard merchandiser



**M7-SO10-1
AIR TOOL LUBRICATION**

- 100ml



Part No.	Description
M7A-RA101P46	Air Regulator
M7A-SW1214	In Line Mini Oiler, 8c.c. Capacity
M7A-QE98L	Double Axis Bubble Spirit Level Gradienter, Suitable For Use With M7 Air Drills
M7-SO1005	Air Tool Oil, 500mL
M7-SO1010	Air Tool Oil, 1L
M7-SO1050	Air Tool Oil, 5L
M7-SO1200	Air Tool Oil, 20L With Provision For A Tap
M7-SG101	Air Tool Lubrication Kit, Applicator And Tube Of Lubricant, 100ml
M7-SO10T	8x Lubrication Grease, With Card Board Merchandiser, 8x 100ml
M7-SO10-1	Air Tool Lubricant, 100mL Tube

- Magnetic Base Drilling Machines
- Cutting Tools
- Clamps
- Engineer's Tools
- Sharpening Machines
- Metal Cutting Saws
- Drilling Machines
- Bevelling Machines & Welding Carriages
- Punches & Shears
- Grinding Machines
- Fans & Ventilators
- Workshop Storage
- M7 Airtools
- NPK Airtools
- Pneumatic Products





IMPACT SOCKETS

HUGE RANGE AVAILABLE

- Sizes : 1/4", 3/8", 1/2", 3/4", 1" & 1-1/2" Drive
- Metric & Imperial
- Deep Sockets
- Budd Wheel Sockets
- In-hex Sockets
- Socket Accessories

WWW.M7AIRTOOLS.COM



IMPACT SOCKETS - 6 POINT

1/4" DRIVE METRIC



Part No.	Diameter	D1	D2	I	L
	mm	mm	mm	mm	mm
M7-MA211M04	4	7.5	13	5	23
M7-MA211M05	5	8.7	13	6	23
M7-MA211M06	6	9.9	13	8	23
M7-MA211M07	7	11.1	13	8	23
M7-MA211M08	8	12.3	13	8	23
M7-MA211M09	9	13.8	13	8	23
M7-MA211M10	10	14.5	13	8	23
M7-MA211M11	11	16.0	13	8	23
M7-MA211M12	12	17.0	13	8	23
M7-MA211M13	13	18.8	13	8	23
M7-MA211M14	14	20.0	13	8	23

1/4" DRIVE IMPERIAL



Part No.	Diameter	D1	D2	I	L
	Inch	mm	mm	mm	mm
M7-MA211S06	3/16"	8.4	13	6	23
M7-MA211S07	7/32"	9.4	13	6	23
M7-MA211S08	1/4"	10.3	13	8	23
M7-MA211S09	9/32"	11.3	13	8	23
M7-MA211S10	5/16"	12.3	13	8	23
M7-MA211S11	11/32"	13.8	13	8	23
M7-MA211S12	3/8"	14.5	13	8	23
M7-MA211S14	7/16"	16.0	13	8	23
M7-MA211S16	1/2"	18.8	13	8	23
M7-MA211S18	9/16"	19.8	13	8	23

1/4" DRIVE DEEP SOCKET METRIC

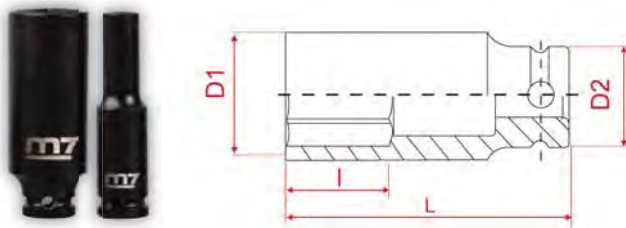

Part No.	Diameter	D1	D2	I	L
	mm	mm	mm	mm	mm
M7-MA231M04	4	7.5	13	7	50
M7-MA231M05	5	8.7	13	9	50
M7-MA231M06	6	9.9	13	11	50
M7-MA231M07	7	11.1	13	11	50
M7-MA231M08	8	12.3	13	13	50
M7-MA231M09	9	13.8	13	13	50
M7-MA231M10	10	14.5	13	13	50
M7-MA231M11	11	16.0	13	13	50
M7-MA231M12	12	17.0	13	13	50
M7-MA231M13	13	18.8	13	13	50
M7-MA231M14	14	20.0	13	13	50

1/4" DRIVE DEEP SOCKET IMPERIAL

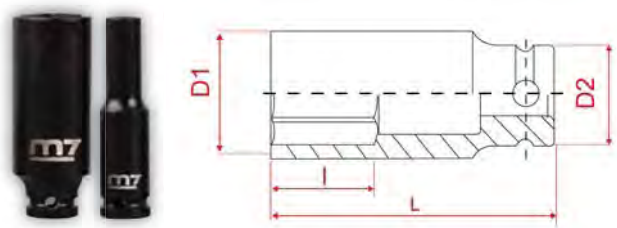

Part No.	Diameter	D1	D2	I	L
	mm	mm	mm	mm	mm
M7-MA231S06	3/16"	8.4	13	9	50
M7-MA231S07	7/32"	9.4	13	9	50
M7-MA231S08	1/4"	10.3	13	11	50
M7-MA231S09	9/32"	11.3	13	11	50
M7-MA231S10	5/16"	12.3	13	13	50
M7-MA231S11	11/32"	13.8	13	13	50
M7-MA231S12	3/8"	14.5	13	13	50
M7-MA231S14	7/16"	16.0	13	13	50
M7-MA231S16	1/2"	18.8	13	13	50
M7-MA231S18	9/16"	19.8	13	13	50

Magnetic Base Drilling Machines

Cutting Tools

Clamps

Engineer's Tools

Sharpening Machines

Metal Cutting Saws

Drilling Machines

Bevelling Machines & Welding Carriages

Punches & Shears

Grinding Machines

Fans & Ventilators

Workshop Storage

M7 Airtools

NPK Airtools

Pneumatic Products



3/8" DRIVE METRIC

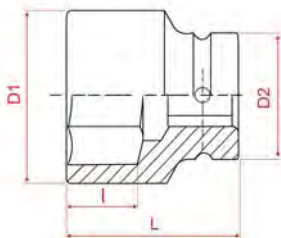

Part No.	Diameter	D1	D2	l	L
	mm	mm	mm	mm	mm
M7-MA311M06	6	10.0	19	9	29.5
M7-MA311M07	7	11.4	19	9	29.5
M7-MA311M08	8	12.7	19	9	29.5
M7-MA311M09	9	14.0	19	10	29.5
M7-MA311M10	10	15.2	19	10	29.5
M7-MA311M11	11	17.0	19	11	29.5
M7-MA311M12	12	18.0	19	11	29.5
M7-MA311M13	13	19.0	19	11	29.5
M7-MA311M14	14	20.0	19	11	29.5
M7-MA311M15	15	21.9	19	13	29.5
M7-MA311M16	16	23.5	22	13	30.0
M7-MA311M17	17	25.0	22	13	30.0
M7-MA311M18	18	26.0	22	13	30.0
M7-MA311M19	19	27.0	22	15	30.0
M7-MA311M20	20	28.0	22	15	30.0
M7-MA311M21	21	30.0	22	15	30.0
M7-MA311M22	22	32.0	22	15	30.0
M7-MA311M23	23	33.0	22	15	30.0
M7-MA311M24	24	34.0	22	15	30.0

3/8" DRIVE DEEP SOCKET METRIC

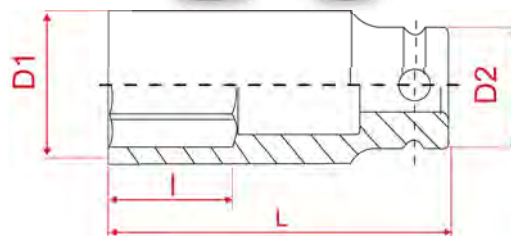

Part No.	Diameter	D1	D2	l	L
	mm	mm	mm	mm	mm
M7-MA331M06	6	10.1	19	14	63
M7-MA331M07	7	11.4	19	14	63
M7-MA331M08	8	12.7	19	14	63
M7-MA331M09	9	14.0	19	14	63
M7-MA331M10	10	15.2	19	20	63
M7-MA331M11	11	17.0	19	20	63
M7-MA331M12	12	18.0	19	22	63
M7-MA331M13	13	19.0	19	24	63
M7-MA331M14	14	20.0	19	26	63
M7-MA331M15	15	22.2	19	27	63
M7-MA331M16	16	23.5	22	26	63
M7-MA331M17	17	25.0	22	26	63
M7-MA331M18	18	26.0	22	26	63
M7-MA331M19	19	27.0	22	26	63
M7-MA331M20	20	28.0	22	26	63
M7-MA331M21	21	30.0	22	26	63
M7-MA331M22	22	32.0	22	26	63
M7-MA331M23	23	33.0	22	26	63



3/8" DRIVE IMPERIAL

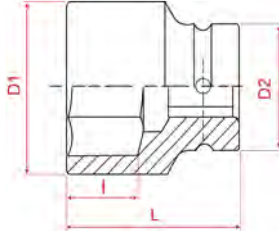

3/8" DRIVE DEEP SOCKET IMPERIAL

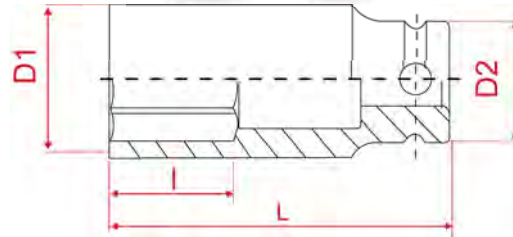

Part No.	Diameter	D1	D2	l	L
	Inch				
M7-MA311S10	5/16"	12.6	19	9	29.5
M7-MA311S12	3/8"	14.6	19	10	29.5
M7-MA311S14	7/16"	17.1	19	11	29.5
M7-MA311S16	1/2"	19.0	19	11	29.5
M7-MA311S18	9/16"	20.0	19	11	29.5
M7-MA311S20	5/8"	23.5	22	13	30.0
M7-MA311S22	11/16"	25.0	22	13	30.0
M7-MA311S24	3/4"	27.0	22	15	30.0
M7-MA311S26	13/16"	30.0	22	15	30.0
M7-MA311S28	7/8"	32.0	22	15	30.0
M7-MA311S30	15/16"	34.0	22	15	30.0
M7-MA311S32	1"	36.0	22	15	30.0

Part No.	Diameter	D1	D2	l	L
	Inch				
M7-MA331S10	5/16"	12.6	19	14	63
M7-MA331S12	3/8"	14.6	19	20	63
M7-MA331S14	7/16"	17.1	19	20	63
M7-MA331S16	1/2"	19.0	19	24	63
M7-MA331S18	9/16"	20.0	19	26	63
M7-MA331S20	5/8"	23.5	22	26	63
M7-MA331S22	11/16"	25.0	22	26	63
M7-MA331S24	3/4"	27.0	22	26	63
M7-MA331S26	13/16"	30.0	22	26	63
M7-MA331S28	7/8"	32.0	22	26	63
M7-MA331S30	15/16"	34.0	22	26	63
M7-MA331S32	1"	36.0	22	26	63

Magnetic Base Drilling Machines

Cutting Tools

Clamps

Engineer's Tools

Sharpening Machines

Metal Cutting Saws

Drilling Machines

Bevelling Machines & Welding Carriages

Punches & Shears

Grinding Machines

Fans & Ventilators

Workshop Storage

M7 Airtools

NPK Airtools

Pneumatic Products





1/2" DRIVE METRIC



1/2" DRIVE DEEP SOCKET METRIC

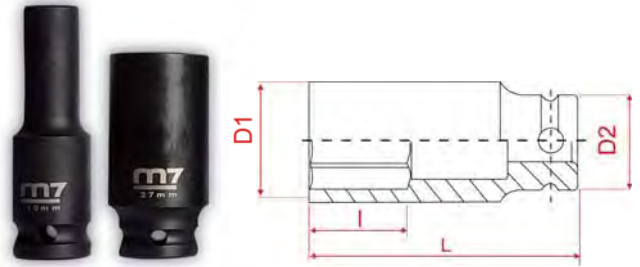

Part No.	Diameter	D1	D2	l	L
	mm	mm	mm	mm	mm
M7-MA411M08	8mm	14.5	24.9	9	38
M7-MA411M09	9mm	15.6	24.9	10	38
M7-MA411M10	10mm	16.7	24.9	10	38
M7-MA411M11	11mm	18.0	24.9	10	38
M7-MA411M12	12mm	19.0	24.9	11	38
M7-MA411M13	13mm	20.2	24.9	11	38
M7-MA411M14	14mm	21.5	24.9	11	38
M7-MA411M15	15mm	23.0	24.9	12	38
M7-MA411M16	16mm	24.9	24.9	12	38
M7-MA411M17	17mm	25.9	25.0	13	38
M7-MA411M18	18mm	26.9	25.0	13	38
M7-MA411M19	19mm	29.9	25.0	13	38
M7-MA411M20	20mm	29.9	25.0	13	38
M7-MA411M21	21mm	32.0	30.0	14.5	38
M7-MA411M22	22mm	32.0	30.0	14.5	38
M7-MA411M23	23mm	34.0	30.0	16	42
M7-MA411M24	24mm	36.0	30.0	17	42
M7-MA411M25	25mm	36.0	30.0	17	42
M7-MA411M26	26mm	38.0	30.0	17	42
M7-MA411M27	27mm	40.0	30.0	19	46
M7-MA411M28	28mm	40.0	30.0	19	46
M7-MA411M29	29mm	39.8	30.0	16	43
M7-MA411M30	30mm	41.9	30.0	19	46
M7-MA411M31	31mm	43.9	30.0	20.5	46
M7-MA411M32	32mm	43.9	30.0	20.5	46
M7-MA411M33	33mm	45.9	35.0	22	46
M7-MA411M34	34mm	45.9	35.0	22	46
M7-MA411M35	35mm	49.9	35.0	22	50
M7-MA411M36	36mm	49.9	35.0	22	50
M7-MA411M37	37mm	50.9	44.0	25	50
M7-MA411M38	38mm	51.9	44.0	25	50

Part No.	Diameter	D1	D2	l	L
	mm	mm	mm	mm	mm
M7-MA431M06	6mm	12.0	24.9	10	82
M7-MA431M07	7mm	13.0	24.9	10	82
M7-MA431M08	8mm	14.5	24.9	13	82
M7-MA431M09	9mm	15.6	24.9	15	82
M7-MA431M10	10mm	16.7	24.9	15	82
M7-MA431M11	11mm	18.0	24.9	15	82
M7-MA431M12	12mm	19.0	24.9	15	82
M7-MA431M13	13mm	20.2	24.9	15	82
M7-MA431M14	14mm	21.5	24.9	18	82
M7-MA431M15	15mm	23.0	25.0	18	82
M7-MA431M16	16mm	24.9	25.0	18	82
M7-MA431M17	17mm	25.9	25.0	19	82
M7-MA431M18	18mm	26.9	25.0	19	82
M7-MA431M19	19mm	29.9	30.0	19	82
M7-MA431M20	20mm	29.9	30.0	26	82
M7-MA431M21	21mm	31.9	30.0	26	82
M7-MA431M22	22mm	31.9	30.0	26	82
M7-MA431M23	23mm	33.9	30.0	26	82
M7-MA431M24	24mm	35.9	30.0	26	82
M7-MA431M25	25mm	35.9	30.0	26	82
M7-MA431M26	26mm	37.9	30.0	26	82
M7-MA431M27	27mm	39.9	30.0	26	82
M7-MA431M28	28mm	39.9	30.0	26	82
M7-MA431M29	29mm	41.9	30.0	26	82
M7-MA431M30	30mm	41.9	30.0	26	82
M7-MA431M31	31mm	43.9	35.0	26	90
M7-MA431M32	32mm	43.9	35.0	26	90
M7-MA431M33	33mm	45.9	35.0	38	90
M7-MA431M34	34mm	45.9	35.0	38	90
M7-MA431M35	35mm	49.9	44.0	38	93
M7-MA431M36	36mm	49.9	44.0	38	93



1/2" DRIVE IMPERIAL



1/2" DRIVE DEEP SOCKET IMPERIAL

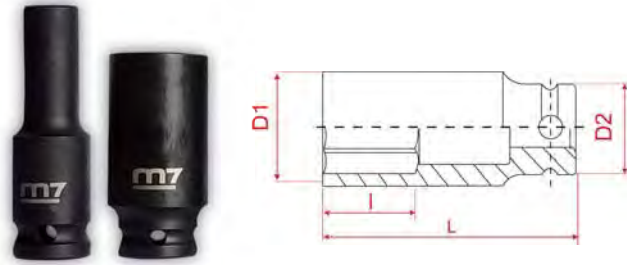

Part No.	Diameter	D1	D2	l	L
	Inch				
M7-MA411S08	1/4"	12.5	24.9	8.0	38
M7-MA411S10	5/16"	14.5	24.9	8.0	38
M7-MA411S12	3/8"	16.0	24.9	8.0	38
M7-MA411S14	7/16"	18.0	24.9	9.0	38
M7-MA411S16	1/2"	20.0	24.9	11.0	38
M7-MA411S18	9/16"	22.0	24.9	11.0	38
M7-MA411S20	5/8"	24.9	24.9	12.0	38
M7-MA411S22	11/16"	26.0	25.0	12.0	38
M7-MA411S24	3/4"	28.0	25.0	12.0	38
M7-MA411S26	13/16"	30.0	25.0	13.0	38
M7-MA411S28	7/8"	32.0	30.0	13.0	38
M7-MA411S30	15/16"	34.0	30.0	15.0	38
M7-MA411S32	1"	36.0	30.0	15.0	38
M7-MA411S34	1-1/16"	38.0	30.0	17.0	40
M7-MA411S36	1-1/8"	40.0	30.0	18.5	40
M7-MA411S38	1-3/16"	42.0	30.0	18.5	40
M7-MA411S40	1-1/4"	44.0	30.0	18.5	40
M7-MA411S42	1-5/16"	46.0	35.0	21.0	43
M7-MA411S44	1-3/8"	48.0	35.0	21.0	43
M7-MA411S46	1-7/16"	50.0	44.0	21.0	43
M7-MA411S48	1-1/2"	52.0	44.0	23.5	43

Part No.	Diameter	D1	D2	l	L
	Inch				
M7-MA431S08	1/4"	12.5	24.9	10	82
M7-MA431S10	5/16"	14.5	24.9	13	82
M7-MA431S12	3/8"	16.0	24.9	15	82
M7-MA431S14	7/16"	18.0	24.9	15	82
M7-MA431S16	1/2"	20.0	24.9	15	82
M7-MA431S18	9/16"	22.0	24.9	17	82
M7-MA431S20	5/8"	24.9	24.9	18	82
M7-MA431S22	11/16"	25.9	25	18	82
M7-MA431S24	3/4"	27.9	25	18	82
M7-MA431S26	13/16"	29.9	25	26	82
M7-MA431S28	7/8"	31.9	30	26	82
M7-MA431S30	15/16"	33.9	30	26	82
M7-MA431S32	1"	35.9	30	26	82
M7-MA431S34	1-1/16"	37.9	30	26	82
M7-MA431S36	1-1/8"	39.9	30	26	82
M7-MA431S38	1-3/16"	41.9	30	26	82
M7-MA431S40	1-1/4"	43.9	30	26	82
M7-MA431S42	1-5/16"	45.9	35	34	90
M7-MA431S44	1-3/8"	47.9	35	34	90
M7-MA431S46	1-7/16"	49.9	44	34	90
M7-MA431S48	1-1/2"	51.8	44	34	90

Magnetic Base Drilling Machines

Cutting Tools

Clamps

Engineer's Tools

Sharpening Machines

Metal Cutting Saws

Drilling Machines

Bevelling Machines & Welding Carriages

Punches & Shears

Grinding Machines

Fans & Ventilators

Workshop Storage

M7 Airtools

NPK Airtools

Pneumatic Products



1/2" DRIVE IN HEX SOCKET METRIC



1/2" DRIVE IN HEX SOCKET IMPERIAL



Part No.	Hex A/F Size	Length
	mm	mm
M7-ME471M04	4	78
M7-ME471M05	5	78
M7-ME471M06	6	78
M7-ME471M07	7	78
M7-ME471M08	8	78
M7-ME471M09	9	78
M7-ME471M10	10	78
M7-ME471M11	11	78
M7-ME471M12	12	78
M7-ME471M14	14	78
M7-ME471M17	17	78
M7-ME471M19	19	78

Part No.	Hex A/F Size	Length
	Inch	mm
M7-ME471S08	1/4"	78
M7-ME471S10	5/16"	78
M7-ME471S12	3/8"	78
M7-ME471S14	7/16"	78
M7-ME471S16	1/2"	78
M7-ME471S18	9/16"	78
M7-ME471S20	5/8"	78
M7-ME471S24	3/4"	78

1/2" DRIVE REVERSIBLE SOCKET METRIC



Part No.	Diameters
	mm
M7-MA412M1719	17, 19
M7-MA412M2122	21, 22



1/2" DRIVE STUBBY METRIC



Part No.	Diameter	Length
	mm	mm
M7-MA401M13	13	28
M7-MA401M17	17	28
M7-MA401M19	19	28
M7-MA401M21	21	28
M7-MA401M22	22	28
M7-MA401M24	24	28

1/2" DRIVE STUBBY IMPERIAL



Part No.	Diameter	Length
	Inch	mm
M7-MA401S16	1/2"	28
M7-MA401S18	9/16"	28
M7-MA401S20	5/8"	28
M7-MA401S22	11/16"	28
M7-MA401S24	3/4"	28
M7-MA401S28	7/8"	28

Magnetic Base Drilling Machines

Cutting Tools

Clamps

Engineer's Tools

Sharpening Machines

Metal Cutting Saws

Drilling Machines

Bevelling Machines & Welding Carriages

Punches & Shears

Grinding Machines

Fans & Ventilators

Workshop Storage

M7 Airtools

NPK Airtools

Pneumatic Products





3/4" DRIVE METRIC



Part No.	Diameter	D1	D2	l	L
	mm	mm	mm	mm	mm
M7-MA611M17	17mm	28	38	16	50
M7-MA611M19	19mm	30	38	16	50
M7-MA611M20	20mm	31	38	16	52
M7-MA611M21	21mm	32	38	18	52
M7-MA611M22	22mm	34	38	18	52
M7-MA611M23	23mm	35	38	18	52
M7-MA611M24	24mm	36	38	18	52
M7-MA611M25	25mm	38	38	18	52
M7-MA611M26	26mm	40	40	18	52
M7-MA611M27	27mm	40	40	18	52
M7-MA611M28	28mm	42	42	19	52
M7-MA611M29	29mm	42	42	19	52
M7-MA611M30	30mm	44	44	19	52
M7-MA611M31	31mm	44	44	20	52
M7-MA611M32	32mm	44	44	22	52
M7-MA611M33	33mm	47	44	22	56
M7-MA611M34	34mm	48	44	22	56
M7-MA611M35	35mm	50	44	22	56
M7-MA611M36	36mm	51	44	22	56
M7-MA611M37	37mm	52	44	22	56
M7-MA611M38	38mm	53	44	22	56
M7-MA611M40	40mm	56	44	26	62
M7-MA611M41	41mm	58	44	26	62
M7-MA611M42	42mm	61	44	26	62
M7-MA611M43	43mm	63	44	27	63
M7-MA611M44	44mm	65	44	27	63
M7-MA611M45	45mm	66	44	27	63
M7-MA611M46	46mm	67	44	27	63
M7-MA611M47	47mm	68	44	32	68
M7-MA611M48	48mm	69	44	32	68

Part No.	Diameter	D1	D2	l	L
	mm	mm	mm	mm	mm
M7-MA611M49	49mm	70	44	34	70
M7-MA611M50	50mm	71	54	35	72
M7-MA611M52	52mm	74	54	35	72
M7-MA611M54	54mm	77	54	35	72
M7-MA611M55	55mm	77	54	35	74
M7-MA611M56	56mm	80	54	35	74
M7-MA611M60	60mm	84	54	35	75
M7-MA611M63	63mm	86	54	35	75
M7-MA611M65	65mm	88	54	35	78



3/4" DRIVE DEEP SOCKET METRIC

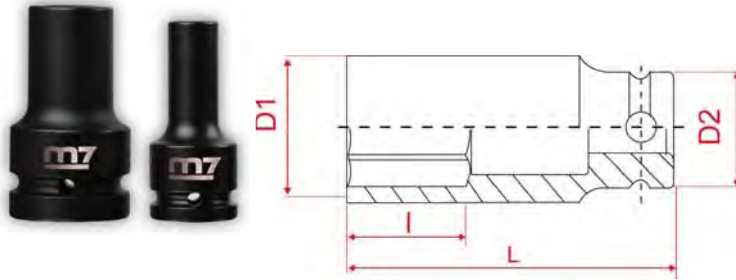

Part No.	Diameter	D1	D2	I	L
	mm	mm	mm	mm	mm
M7-MA631M19	19mm	30	38	11.5	85
M7-MA631M20	20mm	31	38	12.0	85
M7-MA631M21	21mm	32	38	12.0	85
M7-MA631M22	22mm	34	38	12.5	85
M7-MA631M23	23mm	35	38	13.0	85
M7-MA631M24	24mm	36	38	14.0	85
M7-MA631M25	25mm	38	38	35.0	85
M7-MA631M26	26mm	40	40	35.0	85
M7-MA631M27	27mm	40	40	35.0	85
M7-MA631M28	28mm	42	42	35.0	85
M7-MA631M29	29mm	42	42	35.0	85
M7-MA631M30	30mm	44	44	35.0	85
M7-MA631M31	31mm	44	44	35.0	85
M7-MA631M32	32mm	44	44	35.0	85
M7-MA631M33	33mm	47	44	35.0	85
M7-MA631M34	34mm	48	44	35.0	85
M7-MA631M35	35mm	50	44	40.0	85
M7-MA631M36	36mm	51	44	40.0	85
M7-MA631M37	37mm	52	44	40.0	85
M7-MA631M38	38mm	53	44	40.0	85
M7-MA631M40	40mm	56	44	40.0	85
M7-MA631M41	41mm	58	44	45.0	85
M7-MA631M42	42mm	61	44	45.0	85
M7-MA631M43	43mm	63	44	55.0	95
M7-MA631M44	44mm	65	44	55.0	95
M7-MA631M45	45mm	66	44	55.0	95
M7-MA631M46	46mm	67	44	55.0	95
M7-MA631M47	47mm	68	44	55.0	95
M7-MA631M48	48mm	69	44	55.0	95

Part No.	Diameter	D1	D2	I	L
	mm	mm	mm	mm	mm
M7-MA631M49	49mm	70	44	55	95
M7-MA631M50	50mm	71	54	55	95
M7-MA631M52	52mm	74	54	55	95
M7-MA631M55	55mm	77	54	55	100
M7-MA631M60	60mm	84	54	55	105
M7-MA631M65	65mm	88	54	55	105

Magnetic Base Drilling Machines

Cutting Tools

Clamps

Engineer's Tools

Sharpening Machines

Metal Cutting Saws

Drilling Machines

Bevelling Machines & Welding Carriages

Punches & Shears

Grinding Machines

Fans & Ventilators

Workshop Storage

M7 Airtools

NPK Airtools

Pneumatic Products





3/4" DRIVE IMPERIAL

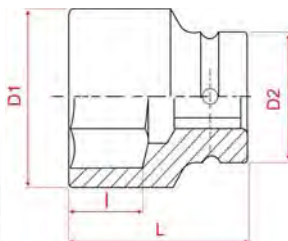

Part No.	Diameter	D1	D2	I	L
	mm	mm	mm	mm	mm
M7-MA611S16	1/2"	22.0	38	16	50
M7-MA611S18	9/16"	26.5	38	16	50
M7-MA611S20	5/8"	27.5	38	16	50
M7-MA611S22	11/16"	29.0	38	16	50
M7-MA611S24	3/4"	30.0	38	16	50
M7-MA611S26	13/16"	32.0	38	18	52
M7-MA611S28	7/8"	34.0	38	18	52
M7-MA611S30	15/16"	36.0	38	18	52
M7-MA611S32	1"	40.0	40	18	52
M7-MA611S34	1-1/16"	40.0	40	18	52
M7-MA611S36	1-1/8"	42.0	42	18	52
M7-MA611S38	1-3/16"	44.0	44	18	52
M7-MA611S40	1-1/4"	44.0	44	18	52
M7-MA611S42	1-5/16"	47.0	44	22	56
M7-MA611S44	1-3/8"	50.0	44	22	56
M7-MA611S46	1-7/16"	51.0	44	22	56
M7-MA611S48	1-1/2"	53.0	44	22	56
M7-MA611S50	1-9/16"	56.0	44	25	62
M7-MA611S52	1-5/8"	58.0	44	25	62
M7-MA611S54	1-11/16"	63.5	44	25	62
M7-MA611S56	1-3/4"	65.0	44	25	62
M7-MA611S58	1-13/16"	67.0	44	25	68
M7-MA611S60	1-7/8"	68.0	44	25	68
M7-MA611S62	1-15/16"	70.0	44	33	70
M7-MA611S64	2"	71.0	54	33	72
M7-MA611S66	2-1/16"	74.0	54	33	72
M7-MA611S68	2-1/8"	77.0	54	33	72
M7-MA611S70	2-3/16"	77.0	54	33	74
M7-MA611S72	2-1/4"	80.0	54	33	74
M7-MA611S74	2-5/16"	82.0	54	33	75
M7-MA611S76	2-3/8"	84.0	54	33	75
M7-MA611S78	2-7/16"	85.0	54	33	75

Part No.	Diameter	D1	D2	I	L
	mm	mm	mm	mm	mm
M7-MA611S80	2-1/2"	86.0	54	33	75
M7-MA611S82	2-9/16"	89.0	62	36	78
M7-MA611S84	2-5/8"	91.0	62	38	80
M7-MA611S86	2-11/16"	93.0	62	38	80
M7-MA611S88	2-3/4"	95.0	62	40	82
M7-MA611S90	2-13/16"	98.0	62	40	82
M7-MA611S92	2-7/8"	100.0	62	40	82
M7-MA611S94	2-15/16"	102.0	62	40	85
M7-MA611S96	3"	104.0	62	40	87



3/4" DRIVE DEEP SOCKET IMPERIAL



Part No.	Diameter	D1	D2	l	L
	Inch				
M7-MA631S16	1/2"	22.0	38	20	85
M7-MA631S18	9/16"	26.5	38	20	85
M7-MA631S20	5/8"	27.5	38	20	85
M7-MA631S22	11/16"	29.0	38	20	85
M7-MA631S24	3/4"	30.0	38	20	85
M7-MA631S26	13/16"	32.0	38	25	85
M7-MA631S28	7/8"	34.0	38	25	85
M7-MA631S30	15/16"	36.0	38	25	85
M7-MA631S32	1"	40.0	40	35	85
M7-MA631S34	1-1/16"	40.0	40	35	85
M7-MA631S36	1-1/8"	42.0	42	35	85
M7-MA631S38	1-3/16"	44.0	44	35	85
M7-MA631S40	1-1/4"	44.0	44	35	85
M7-MA631S42	1-5/16"	47.0	44	35	85
M7-MA631S44	1-3/8"	50.0	44	40	85
M7-MA631S46	1-7/16"	51.0	44	40	85
M7-MA631S48	1-1/2"	53.0	44	40	85
M7-MA631S50	1-9/16"	56.0	44	40	85
M7-MA631S52	1-5/8"	58.0	44	45	85
M7-MA631S54	1-11/16"	63.5	44	45	85
M7-MA631S56	1-3/4"	65.0	44	45	85
M7-MA631S58	1-13/16"	67.0	44	45	85
M7-MA631S60	1-7/8"	68.0	44	45	85
M7-MA631S62	1-15/16"	70.0	44	45	85
M7-MA631S64	2"	71.0	54	45	85
M7-MA631S66	2-1/16"	74.0	54	55	95
M7-MA631S68	2-1/8"	77.0	54	55	95
M7-MA631S70	2-3/16"	77.0	54	55	95
M7-MA631S72	2-1/4"	80.0	54	55	95
M7-MA631S74	2-5/16"	82.0	54	55	95
M7-MA631S76	2-3/8"	84.0	54	55	95
M7-MA631S78	2-7/16"	85.0	54	55	95

Part No.	Diameter	D1	D2	l	L
	Inch				
M7-MA631S80	2-1/2"	86.0	54	55	95
M7-MA631S82	2-9/16"	89.0	62	46	100
M7-MA631S84	2-5/8"	91.0	62	50	100
M7-MA631S86	2-11/16"	93.0	62	56	105
M7-MA631S88	2-3/4"	95.0	62	56	105
M7-MA631S90	2-13/16"	98.0	62	67	110
M7-MA631S92	2-7/8"	100.0	62	67	110
M7-MA631S94	2-15/16"	102.0	62	80	120
M7-MA631S96	3"	104.0	62	80	120

Magnetic Base Drilling Machines

Cutting Tools

Clamps

Engineer's Tools

Sharpening Machines

Metal Cutting Saws

Drilling Machines

Bevelling Machines & Welding Carriages

Punches & Shears

Grinding Machines

Fans & Ventilators

Workshop Storage

M7 Airtools

NPK Airtools

Pneumatic Products





3/4" DRIVE DEEP SOCKET IMPERIAL - 12 POINT



Part No.	Diameter	D1	D2	l	L
	Inch	mm	mm	mm	mm
M7-MA651S24	3/4"	30	40	9.1	85
M7-MA651S80	2-1/2"	86	54	34.4	95

3/4" DRIVE IN HEX SOCKET METRIC



Part No.	Hex A/F Size	D2	Length
	mm	mm	mm
M7-ME671M10	10	44	100
M7-ME671M12	12	44	100
M7-ME671M14	14	44	100
M7-ME671M17	17	44	100
M7-ME671M19	19	44	100
M7-ME671M22	22	44	100
M7-ME671M24	24	44	100
M7-ME671M27	27	44	100

3/4" DRIVE IN HEX SOCKET IMPERIAL



Part No.	Hex A/F Size	D2	Length
	Inch	mm	mm
M7-ME671S12	3/8"	44	100
M7-ME671S14	7/16"	44	100
M7-ME671S16	1/2"	44	100
M7-ME671S18	9/16"	44	100
M7-ME671S20	5/8"	44	100
M7-ME671S22	11/16"	44	100
M7-ME671S24	3/4"	44	100



1" DRIVE METRIC



Part No.	Diameter mm	D1 mm	D2 mm	I mm	L mm
M7-MA811M19	19mm	36.0	51.0	19	58
M7-MA811M21	21mm	38.0	51.0	19	58
M7-MA811M22	22mm	39.0	51.0	19	58
M7-MA811M23	23mm	40.0	51.0	19	58
M7-MA811M24	24mm	40.0	51.0	19	58
M7-MA811M25	25mm	41.0	51.0	19	58
M7-MA811M26	26mm	42.5	51.0	19	58
M7-MA811M27	27mm	44.0	51.0	19	58
M7-MA811M28	28mm	45.0	51.0	19	58
M7-MA811M29	29mm	46.0	51.0	21	60
M7-MA811M30	30mm	48.0	51.0	21	60
M7-MA811M31	31mm	51.0	48.0	21	60
M7-MA811M32	32mm	51.0	51.0	21	60
M7-MA811M33	33mm	53.0	52.0	23	62
M7-MA811M34	34mm	54.0	52.0	23	62
M7-MA811M35	35mm	54.0	52.0	23	62
M7-MA811M36	36mm	56.0	52.0	23	62
M7-MA811M38	38mm	58.0	52.0	23	62
M7-MA811M40	40mm	60.0	52.0	23	62
M7-MA811M41	41mm	61.5	52.0	23	62
M7-MA811M42	42mm	63.0	52.0	25	64
M7-MA811M43	43mm	65.0	52.0	25	64
M7-MA811M44	44mm	66.0	58.0	25	64
M7-MA811M45	45mm	67.0	58.0	25	64
M7-MA811M46	46mm	68.0	58.0	25	64
M7-MA811M48	48mm	71.0	58.0	26	66
M7-MA811M50	50mm	73.0	58.0	31	70
M7-MA811M52	52mm	75.0	58.0	31	70
M7-MA811M54	54mm	78.0	58.0	31	70
M7-MA811M55	55mm	79.0	62.0	33	72
M7-MA811M56	56mm	80.0	62.0	35	74
M7-MA811M58	58mm	85.0	62.0	36	75
M7-MA811M60	60mm	87.0	62.0	37	78
M7-MA811M63	63mm	91.0	62.0	54	80
M7-MA811M65	65mm	93.0	62.0	38	80
M7-MA811M70	70mm	98.0	62.0	42	85
M7-MA811M75	75mm	?	?	?	?

1" DRIVE DEEP SOCKET METRIC

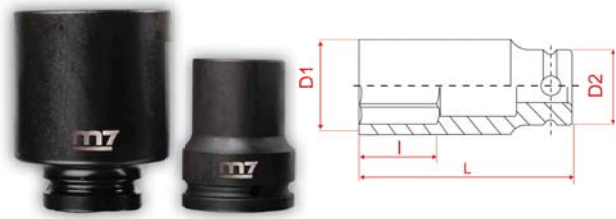

Part No.	Diameter mm	D1 mm	D2 mm	I mm	L mm
M7-MA831M19	19mm	36.0	51	25	58
M7-MA831M21	21mm	38.0	51	25	58
M7-MA831M22	22mm	39.0	51	25	58
M7-MA831M23	23mm	40.0	51	25	58
M7-MA831M24	24mm	40.0	51	25	58
M7-MA831M25	25mm	41.0	51	30	58
M7-MA831M26	26mm	42.5	51	30	58
M7-MA831M27	27mm	44.0	51	30	58
M7-MA831M28	28mm	45.0	51	30	58
M7-MA831M29	29mm	46.0	51	30	60
M7-MA831M30	30mm	48.0	51	35	60
M7-MA831M32	32mm	51.0	51	35	60
M7-MA831M33	33mm	53.0	52	35	62
M7-MA831M34	34mm	54.0	52	40	62
M7-MA831M35	35mm	54.0	52	40	62
M7-MA831M36	36mm	56.0	52	40	62
M7-MA831M38	38mm	58.0	52	40	62
M7-MA831M40	40mm	60.0	52	40	62
M7-MA831M41	41mm	61.5	52	40	62
M7-MA831M42	42mm	63.0	52	40	64
M7-MA831M43	43mm	65.0	52	40	64
M7-MA831M44	44mm	66.0	58	40	64
M7-MA831M45	45mm	67.0	58	40	64
M7-MA831M46	46mm	68.0	58	40	64
M7-MA831M50	50mm	73.0	58	45	70
M7-MA831M51	51mm	74.0	58	58	95
M7-MA831M52	52mm	75.0	58	45	70
M7-MA831M54	54mm	78.0	58	45	70
M7-MA831M55	55mm	79.0	62	50	72
M7-MA831M56	56mm	80.0	62	50	74
M7-MA831M58	58mm	85.0	62	55	75
M7-MA831M60	60mm	87.0	62	55	78
M7-MA831M65	65mm	93.0	62	70	80
M7-MA831M70	70mm	98.0	62	75	85

Magnetic Base Drilling Machines

Cutting Tools

Clamps

Engineer's Tools

Sharpening Machines

Metal Cutting Saws

Drilling Machines

Bevelling Machines & Welding Carriages

Punches & Shears

Grinding Machines

Fans & Ventilators

Workshop Storage

M7 Airtools

NPK Airtools

Pneumatic Products





1" DRIVE IMPERIAL



Part No.	Diameter	D1	D2	I	L
	Inch				
M7-MA811S024	3/4"	36.0	50.9	18	58
M7-MA811S026	13/16"	38.0	50.9	18	58
M7-MA811S028	7/8"	39.0	50.9	18	58
M7-MA811S030	15/16"	40.0	50.9	18	58
M7-MA811S032	1"	42.0	50.9	18	58
M7-MA811S034	1-1/16"	44.0	50.9	18	58
M7-MA811S036	1-1/8"	46.0	50.9	18	58
M7-MA811S038	1-3/16"	48.0	50.9	20	60
M7-MA811S040	1-1/4"	50.9	50.9	20	60
M7-MA811S042	1-5/16"	52.9	52.0	22	62
M7-MA811S044	1-3/8"	53.9	52.0	22	62
M7-MA811S046	1-7/16"	55.9	52.0	22	62
M7-MA811S048	1-1/2"	58.0	52.0	22	62
M7-MA811S050	1-9/16"	60.0	52.0	22	62
M7-MA811S052	1-5/8"	61.5	52.0	22	62
M7-MA811S054	1-11/16"	65.0	52.0	24	64
M7-MA811S056	1-3/4"	66.0	58.0	24	64
M7-MA811S058	1-13/16"	68.0	58.0	24	64
M7-MA811S060	1-7/8"	70.0	58.0	26	66
M7-MA811S062	1-15/16"	72.0	58.0	28	68
M7-MA811S064	2"	74.0	58.0	30	70
M7-MA811S066	2-1/16"	75.0	58.0	30	70
M7-MA811S068	2-1/8"	78.0	58.0	30	70
M7-MA811S070	2-3/16"	80.0	62.0	33	72
M7-MA811S072	2-1/4"	84.0	62.0	35	75
M7-MA811S074	2-5/16"	86	62.0	35	75
M7-MA811S076	2-3/8"	87.0	62.0	36	78
M7-MA811S078	2-7/16"	89.0	62.0	36	78
M7-MA811S080	2-1/2"	91.0	62.0	37	80
M7-MA811S082	2-9/16"	93.0	62.0	37	80

Part No.	Diameter	D1	D2	I	L
	Inch				
M7-MA811S084	2-5/8"	95.0	62.0	39	82
M7-MA811S086	2-11/16"	97.0	62.0	39	82
M7-MA811S088	2-3/4"	98.0	62.0	41	85
M7-MA811S090	2-13/16"	100.0	62.0	41	87
M7-MA811S092	2-7/8"	102.0	62.0	41	87
M7-MA811S094	2-15/16"	104.0	86.0	50	95
M7-MA811S096	3"	106.0	86.0	52	98
M7-MA811S100	3-1/8"	109.0	86.0	52	100
M7-MA811S104	3-1/4"	113.0	86.0	52	100
M7-MA811S108	3-3/8"	115.0	86.0	52	100
M7-MA811S112	3-1/2"	119.0	86.0	52	105
M7-MA811S116	3-5/8"	127.0	86.0	52	110
M7-MA811S120	3-3/4"	130.0	86.0	52	110
M7-MA811S124	3-7/8"	136.0	95.0	52	110
M7-MA811S128	4"	140.0	95.0	62	120
M7-MA811S132	4-1/8"	143.0	95.0	62	120
M7-MA811S136	4-1/4"	146.0	95.0	62	120
M7-MA811S144	4-1/2"	152.0	95.0	62	120

1" DRIVE IN HEX SOCKET METRIC



Part No.	Hex A/F Size	D2	Length
	mm		
M7-ME871M14	14	54	100
M7-ME871M17	17	54	100
M7-ME871M19	19	54	100
M7-ME871M22	22	54	100
M7-ME871M24	24	54	100
M7-ME871M27	27	54	100



1" DRIVE DEEP SOCKET IMPERIAL

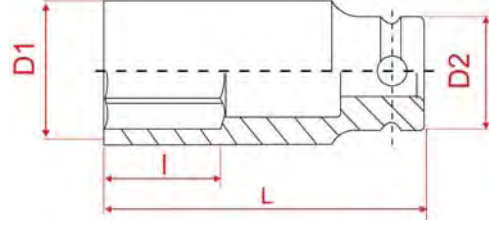

Part No.	Diameter	D1	D2	I	L
	mm	mm	mm	mm	mm
M7-MA831S024	3/4"	36.0	51	27	90
M7-MA831S026	13/16"	38.0	51	27	90
M7-MA831S028	7/8"	39.0	51	27	90
M7-MA831S030	15/16"	40.0	51	27	90
M7-MA831S032	1"	42.0	51	32	90
M7-MA831S034	1-1/16"	44.0	51	32	90
M7-MA831S036	1-1/8"	46.0	51	32	90
M7-MA831S038	1-3/16"	48.0	51	37	90
M7-MA831S040	1-1/4"	51.0	51	37	90
M7-MA831S042	1-5/16"	53.0	52	37	90
M7-MA831S044	1-3/8"	54.0	52	42	90
M7-MA831S046	1-7/16"	56.0	52	42	90
M7-MA831S048	1-1/2"	58.0	52	42	92
M7-MA831S050	1-9/16"	60.0	52	42	92
M7-MA831S052	1-5/8"	61.5	52	42	92
M7-MA831S054	1-11/16"	65.0	52	42	92
M7-MA831S056	1-3/4"	66.0	58	42	92
M7-MA831S058	1-13/16"	68.0	58	42	92
M7-MA831S060	1-7/8"	70.0	58	42	92
M7-MA831S062	1-15/16"	72.0	58	42	92
M7-MA831S064	2"	74.0	58	52	95
M7-MA831S066	2-1/16"	75.0	58	52	95
M7-MA831S068	2-1/8"	78.0	58	52	95
M7-MA831S070	2-3/16"	80.0	62	52	100
M7-MA831S072	2-1/4"	84.0	62	52	100
M7-MA831S074	2-5/16"	86.0	62	57	105
M7-MA831S076	2-3/8"	87.0	62	57	105
M7-MA831S078	2-7/16"	89.0	62	62	110
M7-MA831S080	2-1/2"	91.0	62	62	110
M7-MA831S082	2-9/16"	93.0	62	72	120

Part No.	Diameter	D1	D2	I	L
	mm	mm	mm	mm	mm
M7-MA831S084	2-5/8"	95.0	62	72	120
M7-MA831S086	2-11/16"	97.0	62	77	124
M7-MA831S088	2-3/4"	98.0	62	77	124
M7-MA831S090	2-13/16"	100.0	62	82	128
M7-MA831S092	2-7/8"	102.0	62	82	128
M7-MA831S094	2-15/16"	104.0	86	87	135
M7-MA831S096	3"	106.0	86	87	135
M7-MA831S100	3-1/8"	109.0	86	87	135
M7-MA831S104	3-1/4"	113.0	86	87	135
M7-MA831S108	3-3/8"	115.0	86	87	135
M7-MA831S112	3-1/2"	119.0	86	87	135
M7-MA831S116	3-5/8"	127.0	86	90	140
M7-MA831S120	3-3/4"	130.0	86	90	140
M7-MA831S124	3-7/8"	136.0	95	90	140
M7-MA831S128	4"	140.0	95	105	155
M7-MA831S132	4-1/8"	143.0	95	105	155
M7-MA831S136	4-1/4"	146.0	95	105	155
M7-MA831S144	4-1/2"	152.0	95	105	155

BUDD WHEEL SOCKETS

1" DRIVE BUDD WHEEL SOCKETS METRIC & IMPERIAL

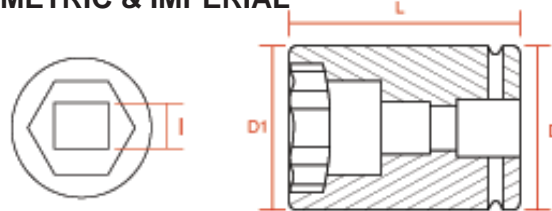

Part No.	Diameter	D1	D2	I	L
	mm	mm	mm	mm	mm
M7-MA831M33	33mm	52	52	-	90
M7-MA812M3517	35mm	54	52	17mm	94
M7-MA812M3820	38mm	56	54	20mm	96
M7-MA812M4121	41mm	58	54	21mm	99
M7-MA812S4826	1-1/2"	57	57	13/16"	99

Magnetic
Base
Drilling
Machines

Cutting
Tools

Clamps

Engineer's
Tools

Sharpening
Machines

Metal
Cutting
Saws

Drilling
Machines

Bevelling
Machines
& Welding
Carriages

Punches
& Shears

Grinding
Machines

Fans &
Ventilators

Workshop
Storage

M7
Airtools

NPK
Airtools

Pneumatic
Products



1-1/2" DRIVE METRIC

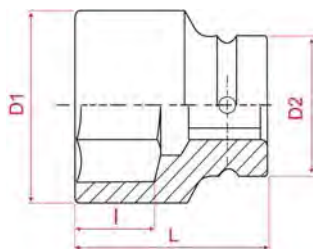

1-1/2" DRIVE DEEP SOCKET METRIC

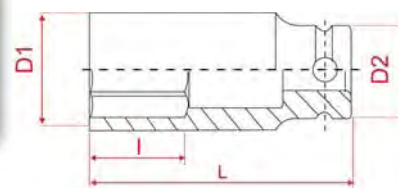

Part No.	Diameter	D1	D2	l	L
	mm	mm	mm	mm	mm
M7-MA911M035	35mm	62	86	23	78
M7-MA911M036	36mm	64	86	23	78
M7-MA911M038	38mm	66	88	23	78
M7-MA911M041	41mm	70	86	26	80
M7-MA911M046	46mm	76	86	27	84
M7-MA911M050	50mm	80	86	29	87
M7-MA911M051	51mm	82	86	29	87
M7-MA911M052	52mm	83	86	30	87
M7-MA911M054	54mm	86	86	36	90
M7-MA911M055	55mm	86	86	36	90
M7-MA911M058	58mm	93	86	38	90
M7-MA911M060	60mm	93	86	38	90
M7-MA911M065	65mm	98	86	40	95
M7-MA911M070	70mm	106	86	43	95
M7-MA911M075	75mm	108	86	45	103
M7-MA911M080	80mm	118	86	50	110
M7-MA911M085	85mm	125	86	50	110
M7-MA911M090	90mm	128	86	55	118
M7-MA911M095	95mm	134	95	55	118
M7-MA911M100	100mm	138	95	58	125
M7-MA911M105	105mm	142	95	58	125
M7-MA911M110	110mm	148	95	66	135
M7-MA911M115	115mm	158	95	66	135
M7-MA911M120	120mm	165	95	66	135
M7-MA911M130	130mm	178	127	72	140

Part No.	Diameter	D1	D2	l	L
	mm	mm	mm	mm	mm
M7-MA931M041	41mm	70	86	32	115
M7-MA931M051	51mm	82	86	38	135
M7-MA931M054	54mm	86	86	36	140
M7-MA931M055	55mm	86	86	36	140
M7-MA931M058	58mm	93	86	43	150
M7-MA931M060	60mm	93	86	45	150
M7-MA931M065	65mm	98	86	47	150
M7-MA931M070	70mm	106	86	49	160
M7-MA931M075	75mm	108	86	53	170
M7-MA931M078	78mm	115	86	53	170
M7-MA931M080	80mm	118	86	53	170
M7-MA931M085	85mm	125	86	58	170
M7-MA931M090	90mm	128	86	62	170
M7-MA931M095	95mm	134	95	65	180
M7-MA931M098	98mm	137	95	65	180
M7-MA931M100	100mm	138	95	68	190
M7-MA931M110	110mm	148	95	75	190
M7-MA931M115	115mm	158	95	80	210
M7-MA931M120	120mm	165	95	80	210
M7-MA931M125	125mm	168	95	80	210



1-1/2" DRIVE IMPERIAL

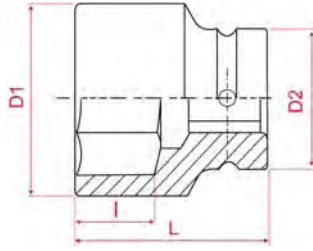

1-1/2" DRIVE DEEP SOCKET IMPERIAL

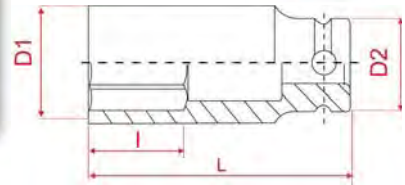

Part No.	Diameter	D1	D2	I	L
	Inch	mm	mm	mm	mm
M7-MA911S048	1-1/2"	66	86	24	78
M7-MA911S052	1-5/8"	70	86	27	80
M7-MA911S056	1-3/4"	75	86	28.5	84
M7-MA911S060	1-7/8"	78	86	30	84
M7-MA911S064	2"	82	86	32	87
M7-MA911S072	2-1/4"	86	86	36	92
M7-MA911S076	2-3/8"	93	86	38.5	92
M7-MA911S080	2-1/2"	97	86	40.5	95
M7-MA911S084	2-5/8"	103	86	42.5	100
M7-MA911S088	2-3/4"	105	86	44.5	100
M7-MA911S092	2-7/8"	108	86	46.5	103
M7-MA911S096	3"	110	86	48	103
M7-MA911S104	3-1/4"	125	86	52	110
M7-MA911S112	3-1/2"	130	86	57.5	118
M7-MA911S120	3-3/4"	137	95	60.5	118
M7-MA911S128	4"	145	95	63.5	125
M7-MA911S136	4-1/4"	153	95	70	125
M7-MA911S144	4-1/2"	163	95	72	135
M7-MA911S152	4-3/4"	168	95	76.5	135
M7-MA911S160	5"	179	127	77	140

Part No.	Diameter	D1	D2	I	L
	Inch	mm	mm	mm	mm
M7-MA931S048	1-1/2"	66	86	23	115
M7-MA931S052	1-5/8"	70	86	27	115
M7-MA931S056	1-3/4"	75	86	28.5	115
M7-MA931S060	1-7/8"	78	86	30	115
M7-MA931S064	2"	82	86	32	135
M7-MA931S072	2-1/4"	86	86	36	150
M7-MA931S076	2-3/8"	93	86	38.5	150
M7-MA931S080	2-1/2"	97	86	40.5	150
M7-MA931S084	2-5/8"	103	86	42.5	150
M7-MA931S088	2-3/4"	105	86	45	160
M7-MA931S092	2-7/8"	108	86	46.5	160
M7-MA931S096	3"	110	86	48	170
M7-MA931S104	3-1/4"	125	86	52	170
M7-MA931S112	3-1/2"	130	86	57.5	170
M7-MA931S120	3-3/4"	137	95	60.5	180
M7-MA931S128	4"	145	95	63.5	190
M7-MA931S136	4-1/4"	153	95	70	190
M7-MA931S144	4-1/2"	163	95	72	210
M7-MA931S152	4-3/4"	168	95	76.5	210

Magnetic Base Drilling Machines

Cutting Tools

Clamps

Engineer's Tools

Sharpening Machines

Metal Cutting Saws

Drilling Machines

Bevelling Machines & Welding Carriages

Punches & Shears

Grinding Machines

Fans & Ventilators

Workshop Storage

M7 Airtools

NPK Airtools

Pneumatic Products



IMPACT SOCKET ACCESSORIES

SOCKET RAIL

- Magnetic
- Sockets not included



Part No.	Diameter	Length
M7-MAD2212	1/4" Drive	300mm
M7-MAD2312	3/8" Drive	300mm
M7-MAD2412	1/2" Drive	300mm
M7-MAD2218	1/4" Drive	457mm
M7-MAD2318	3/8" Drive	457mm
M7-MAD2418	1/2" Drive	457mm

UNIVERSAL JOINT LOCKING BALL TYPE



Part No.	Size	Overall Length
M7-ME2711	1/4" Drive	1-3/4" (65mm)
M7-ME3711	3/8" Drive	2" (51mm)
M7-ME4711	1/2" Drive	2-7/16" (61mm)
M7-ME6711	3/4" Drive	3-1/2" (90.4mm)
M7-ME8711	1" Drive	4-1/2" (114mm)
M7-ME9711	1-1/2" Drive	8-1/2" (170mm)



UNIVERSAL JOINT PIN AND RING TYPE

Part No.	Size	Overall Length
M7-ME4711P	1/2" Drive	2-7/16" (61mm)
M7-ME6711P	3/4" Drive	3-1/2" (90.4mm)

IMPACT SOCKET ADAPTOR LOCKING BALL TYPE



Part No.	Description	Diameter
M7-ME382	3/8" Drive Female x 1/4" Drive Male	22mm
M7-ME384	3/8" Drive Female x 1/2" Drive Male	22mm
M7-ME483	1/2" Drive Female x 3/8" Drive Male	25mm
M7-ME486	1/2" Drive Female x 3/4" Drive Male	30mm
M7-ME684	3/4" Drive Female x 1/2" Drive Male	44mm
M7-ME688	3/4" Drive Female x 1" Drive Male	46mm
M7-ME886	1" Drive Female x 3/4" Drive Male	56mm



IMPACT SOCKET ADAPTOR PIN AND RING TYPE

Part No.	Description	Diameter
M7-ME384P	3/8" Drive Female x 1/2" Drive Male	22mm
M7-ME486P	1/2" Drive Female x 3/4" Drive Male	30mm
M7-ME688P	3/4" Drive Female x 1/2" Drive Male	46mm
M7-ME886P	1" Drive Female x 3/4" Drive Male	56mm
M7-ME889P	1" Drive Female x 1-1/2" Drive Male With Pin Hole	54mm
M7-ME988P	1-1/2" Drive Female x 1" Drive Male With Pin Hole	

IMPACT TORQUE EXTENSION BAR



Part No.	Colour	Diameter	Torque	Length
M7-ME422-090	Yellow	9.0mm	65FT-LB 90Nm	194mm
M7-ME422-110	Dark Blue	11.0mm	80FT-LB 110Nm	194mm
M7-ME422-122	Grey	12.2mm	100FT-LB 135Nm	194mm
M7-ME422-137	White	13.7mm	120FT-LB 160Nm	194mm
M7-ME422-151	Light Blue	15.1mm	140FT-LB 190Nm	194mm
M7-ME422-103	Black	10.3mm	75FT-LB 100Nm	194mm
M7-ME422-114	Beige	11.4mm	90FT-LB 120Nm	194mm
M7-ME422-128	Orange	12.8mm	110FT-LB 150Nm	194mm



IMPACT TORQUE EXTENSION BAR SET

Includes:

- 90Nm
- 135Nm
- 190Nm
- 120Nm
- 150Nm



Part No.	Description
M7-ME4050	Impact Torque Extension Bar 5 Piece Set

IMPACT EXTENSION BAR FOR USE WITH PIN AND RING

Part No.	Diameter	Length
M7-ME321-03P	3/8" Drive	75mm
M7-ME321-06P	3/8" Drive	150mm
M7-ME421-03P	1/2" Drive	75mm
M7-ME421-10P	1/2" Drive	250mm
M7-ME621-04P	3/4" Drive	100mm
M7-ME621-07P	3/4" Drive	175mm
M7-ME621-10P	3/4" Drive	250mm
M7-ME621-13P	3/4" Drive	330mm
M7-ME821-07P	1" Drive	175mm
M7-ME821-10P	1" Drive	250mm
M7-ME821-13P	1" Drive	330mm

PINS



Part No.	Pin Diameter	Pin Length	Sockets To Suit
M7-ME91635	4mm	35mm	3/4" Drive 17mm to 46mm
M7-ME91645	4mm	45mm	3/4" Drive 48mm to 60mm

IMPACT EXTENSION BAR LOCKING BALL TYPE



Part No.	Diameter	Length
M7-ME221-02	1/4" Drive	50mm
M7-ME221-04	1/4" Drive	100mm
M7-ME221-06	1/4" Drive	150mm
M7-ME321-05	3/8" Drive	125mm
M7-ME321-10	3/8" Drive	250mm
M7-ME321-12	3/8" Drive	300mm
M7-ME321-15	3/8" Drive	375mm
M7-ME421-05	1/2" Drive	125mm
M7-ME421-15	1/2" Drive	375mm
M7-ME621-04	3/4" Drive	100mm
M7-ME621-06	3/4" Drive	150mm
M7-ME621-07	3/4" Drive	175mm
M7-ME621-08	3/4" Drive	200mm
M7-ME621-13	3/4" Drive	330mm
M7-ME821-03	1" Drive	75mm
M7-ME821-06	1" Drive	150mm
M7-ME821-07	1" Drive	175mm
M7-ME821-08	1" Drive	200mm
M7-ME821-10	1" Drive	250mm
M7-ME821-12	1" Drive	300mm

RINGS



Part No.	Ring Diameter (A)	Ring Diameter (B)	Sockets To Suit
M7-ME01637	48mm	5mm	3/4" Drive 17mm to 46mm
M7-ME01644	54mm	5mm	3/4" Drive 48mm to 60mm

PIN & RING SETS



Part No.	Pin Diameter	Pin Length	Ring Diameter (A)	Ring Diameter (B)	Sockets To Suit
M7-ME90315	2.5mm	15mm	13.5mm	3.5mm	3/8" Drive 8mm to 24mm
M7-ME90324	2.5mm	18mm	16mm	3.5mm	3/8" Drive 21mm to 32mm
M7-ME90424	4mm	18mm	20mm	4mm	1/2" Drive 8mm to 24mm
M7-ME90432	4mm	25.5mm	25mm	4mm	1/2" Drive 21mm to 32mm
M7-ME90434	4mm	30.5mm	38mm	4mm	1/2" Drive 37mm to 34mm
M7-ME90436	4mm	25.5mm	30mm	4mm	1/2" Drive 33mm to 36mm
M7-ME90458	4mm	39.5mm	46mm	4mm	1/2" Drive 50mm to 58mm
M7-ME90627	4mm	32mm	32mm	4mm	3/4" Drive 17mm to 27mm
M7-ME90646	4mm	35.5mm	36mm	4mm	3/4" Drive 28mm to 49mm
M7-ME90650	4mm	46mm	46mm	4mm	3/4" Drive 50mm to 65mm
M7-ME90836	5mm	46mm	48mm	5mm	1" Drive 19mm to 70mm
M7-ME90860	6mm	80mm	75mm	6mm	1" Drive 2-15/16" to 3-3/4"
M7-ME912090	6mm	75mm	76mm	10mm	1-1/2" Drive 30mm to 90mm
M7-ME912125	6mm	84mm	85mm	10mm	1-1/2" Drive 95mm to 125mm



3/8" IMPACT SOCKET SETS - 6 POINT

3/8" DRIVE METRIC SET



Part No.	Includes
M7-MB34013M	13 Piece, 6, 8, 9, 10, 11, 12, 13, 14, 15, 16, 17, 18, 19mm

1/2" IMPACT SOCKET SETS - 6 POINT

1/2" DRIVE METRIC SET



Part No.	Includes
M7-MB44014M	14 Piece, 10, 11, 12, 13, 14, 15, 16, 17, 18, 19, 21, 22, 26, 27mm

3/8" DRIVE DEEP SOCKET METRIC SET



Part No.	Includes
M7-MB35013M	13 Piece, 6, 8, 9, 10, 11, 12, 13, 14, 15, 16, 17, 18, 19mm

1/2" DRIVE DEEP SOCKET METRIC SET



Part No.	Includes
M7-MB45010M	10 Piece, 10, 12, 13, 14, 15, 17, 19, 21, 24, 27mm

3/8" DRIVE IMPERIAL SET



Part No.	Includes
M7-MB34012S	12 Piece, 5/16", 3/8", 7/16", 1/2", 9/16", 5/8", 11/16", 3/4", 13/16", 7/8", 15/16", 1"

1/2" DRIVE IMPERIAL SET



Part No.	Includes
M7-MB44013S	13 Piece, 7/16", 1/2", 9/16", 5/8", 11/16", 3/4", 13/16", 7/8", 15/16", 1", 1-1/8", 1-3/16", 1-1/4"

3/8" DRIVE DEEP SOCKET IMPERIAL SET



Part No.	Includes
M7-MB35012S	12 Piece, 5/16", 3/8", 7/16", 1/2", 9/16", 5/8", 11/16", 3/4", 13/16", 7/8", 15/16", 1"

1/2" DRIVE DEEP SOCKET IMPERIAL SET



Part No.	Includes
M7-MB45013S	13 Piece, 7/16", 1/2", 9/16", 5/8", 11/16", 3/4", 13/16", 7/8", 15/16", 1", 1-1/8", 1-3/16", 1-1/4"

Magnetic Base Drilling Machines

Cutting Tools

Clamps

Engineer's Tools

Sharpening Machines

Metal Cutting Saws

Drilling Machines

Bevelling Machines & Welding Carriages

Punches & Shears

Grinding Machines

Fans & Ventilators

Workshop Storage

M7 Airtools

NPK Airtools

Pneumatic Products



1/2" DRIVE IN HEX METRIC SET



Part No.	Includes
M7-MB44008M	8 Piece, 6, 7, 8, 10, 12, 14, 17, 19mm

1/2" DRIVE STUBBY METRIC SET 6 PIECE



Part No.	Includes
M7-MA42006M	6 Piece, 13, 17, 19, 21, 22 & 24mm Supplied In Blister Hang Pack

1/2" DRIVE IN HEX IMPERIAL SET



Part No.	Includes
M7-MB44008S	8 Piece, 1/4", 5/16", 3/8", 7/16", 1/2", 9/16", 5/8", 3/4"

1/2" DRIVE STUBBY IMPERIAL SET



Part No.	Includes
M7-MA42006S	6 Piece 1/2", 9/16", 5/8", 11/16", 3/4" & 7/8" Supplied In Blister Hang Pack

1/2" DRIVE STUBBY METRIC SET 15 PIECE



Part No.	Includes
M7-MA42015M	15 Piece, 10, 11, 12, 13, 14, 15, 16, 17, 18, 19, 20, 21, 22, 23, 24mm Supplied In Cardboard Box

1/2" DRIVE DEEP SOCKET METRIC SET

Includes : 17mm, 19mm, 21mm

- Different sizes are easily identified by different colours
- External sheath protects the working object from being rubbed, scratched, impacted...etc.
- 85mm extra long socket allows extra reach for deeper holes



Part No.	Includes
M7-MA4030	3 Piece, 17, 19, 20mm

Magnetic Base Drilling Machines

Cutting Tools

Clamps

Engineer's Tools

Sharpening Machines

Metal Cutting Saws

Drilling Machines

Bevelling Machines & Welding Carriages

Punches & Shears

Grinding Machines

Fans & Ventilators

Workshop Storage

M7 Airtools

NPK Airtools

Pneumatic Products





3/4" IMPACT SOCKET SETS - 6 POINT

3/4" DRIVE METRIC SET



Part No.	Contents
M7-MB64008M	8 Piece, 26, 27, 29, 30, 32, 33, 35, 36mm

3/4" DRIVE DEEP SOCKET METRIC SET



Part No.	Contents
M7-MB65008M	8 Piece, 26, 27, 29, 30, 32, 33, 35, 36mm

3/4" DRIVE IMPERIAL SET



Part No.	Contents
M7-MB64008S	8 Piece, 1", 1-1/16", 1-1/8", 1-1/4", 1-5/16", 1-3/8", 1-7/16" & 1-1/2"

3/4" DRIVE DEEP SOCKET IMPERIAL SET



Part No.	Contents
M7-MB65008S	8 Piece, 1", 1-1/16", 1-1/8", 1-1/4", 1-5/16", 1-3/8", 1-7/16" & 1-1/2"

1" IMPACT BUDD WHEEL SOCKET SET - 6 POINT

IMPACT BUDD WHEEL SOCKET SET



Part No.	Contents
M7-MA8050	5 Piece, 33, 35, 38, 41mm & 1-1/2"



NPK AIR TOOLS

3/8" Drive Impact Wrenches	294	Angle Grinders	302
1/2" Drive Impact Wrenches	294	Vertical Grinders	303
3/4" Drive Impact Wrenches	295	Sanders	303
1" Drive Impact Wrenches	296	Chipping Hammers	304
1-1/2" Drive Impact Wrenches	297	New Kelens	304
1-3/4" Drive Impact Wrenches	297	Flux Scaling Hammers	305
2-1/2" Drive Impact Wrenches	297	Auto Chisellers	305
Drills	298	Sand Rammers	306
Die Grinders	300	Hoists	307
Straight & CNS Grinders	301	Pneumatic Tools	308

3/8" DRIVE AIR IMPACT WRENCHES

NPK-NAW6HS

3/8" DRIVE AIR IMPACT WRENCH

Weight : 1.5kg
 • Twin hammer



Part #	Square Drive	Free Speed	Handle Style	Bolt Capacity	Air Pressure	Avg. Air Cons.	Weight
	Inch	RPM		mm	PSI	CFM	kg
NPK-NAW6HS	3/8"	8000	Straight	6	85	8.8	1.5

1/2" DRIVE AIR IMPACT WRENCHES

NPK-NW1600HA STANDARD ANVIL - PICTURED

NPK-NW1600HA(2R) 2" ANVIL

1/2" DRIVE AIR IMPACT WRENCH

Weight : 2.5kg
 • Single hammer



NPK-NW14H

1/2" DRIVE AIR IMPACT WRENCH

Weight : 3.0kg
 • Twin hammer



NPK-NAW1200

1/2" DRIVE 90° ANGLE AIR IMPACT WRENCH

Weight : 3.0kg



Part #	Square Drive	Free Speed	Handle Style	Bolt Capacity	Air Pressure	Avg. Air Cons.	Weight
	Inch	RPM		mm	PSI	CFM	kg
NPK-NW1600HA	1/2"	5000	Pistol Grip	16	85	5.3	2.5
NPK-NW1600HA(2R)	1/2"	5000	Pistol Grip	16	85	5.3	2.6
NPK-NW14H	1/2"	5500	Pistol Grip	16	85	12.4	3.0
NPK-NAW1200	1/2"	6500	Straight	12	85	3.5	3.0

3/4" DRIVE AIR IMPACT WRENCHES

NPK-NW2000HA

3/4" DRIVE AIR IMPACT WRENCH

- Weight : 3.9kg
 • Single hammer



NPK-NW2800P

3/4" DRIVE AIR IMPACT WRENCH

- Weight : 3.0kg
 • Single hammer



NPK-NW16HP

3/4" DRIVE AIR IMPACT WRENCH

- Weight : 5.0kg
 • Twin hammer



NPK-NW19A

3/4" DRIVE AIR IMPACT WRENCH

- Weight : 6.5kg
 • Twin hammer



NPK-NW22A

3/4" DRIVE AIR IMPACT WRENCH

- Weight : 7.4kg
 • Twin hammer



NPK-NAW19A

3/4" DRIVE 90° ANGLE AIR IMPACT WRENCH

- Weight : 10.6kg
 • Twin hammer



Part #	Square Drive	Free Speed	Handle Style	Bolt Capacity	Air Pressure	Avg. Air Cons.	Weight
	Inch	RPM		mm	PSI	CFM	kg
NPK-NW2000HA	3/4"	5500	Pistol Grip	20	85	7.1	3.9
NPK-NW2800P	3/4"	5000	Pistol Grip	30	85	8.8	5.0
NPK-NW16HP	3/4"	5000	Pistol Grip	18	85	15.9	5.0
NPK-NW19A	3/4"	4500	D Outside Trigger	20	85	19.4	6.5
NPK-NW22A	3/4"	4500	D Outside Trigger	22	85	21.2	7.4
NPK-NAW19A	3/4"	4000	D Outside Trigger	18	85	17.7	10.6

1" DRIVE AIR IMPACT WRENCHES

NPK-NWH320P**1" DRIVE AIR IMPACT WRENCH**

Weight : 9.0kg

- Clutch Hammer

**NPK-NW3500P****1" DRIVE AIR IMPACT WRENCH**

Weight : 9.2kg

- Single hammer

**NPK-NW4300GAU****1" DRIVE AIR IMPACT WRENCH**

Weight : 12.9kg

- Single hammer

**NPK-NW5000A****1" DRIVE AIR IMPACT WRENCH**

Weight : 16.5kg

- Single hammer

**NPK-NW32LA****1" DRIVE AIR IMPACT WRENCH**

Weight : 9.7kg

- Twin hammer

**NPK-NAW32LA****1" DRIVE 90° ANGLE AIR IMPACT WRENCH**

Weight : 18.0kg

- Twin hammer



Part #	Square Drive	Free Speed	Handle Style	Bolt Capacity	Air Pressure	Avg. Air Cons.	Weight
	Inch	RPM		mm	PSI	CFM	kg
NPK-NWH320P	1"	4000	Pistol Grip	39	85	17.7	9.0
NPK-NW3500P	1"	4000	Pistol Grip	36	85	10.6	9.2
NPK-NW4300GAU	1"	4000	D Inside Trigger	42	85	14.1	12.9
NPK-NW5000A	1"	3000	D Inside Trigger	52	85	15.9	16.5
NPK-NW32LA	1"	4000	D Inside Trigger	33	85	30.0	9.7
NPK-NAW32LA	1"	3500	D Inside Trigger	22	85	30.0	18.0

1" DRIVE AIR IMPACT WRENCHES

NPK-NWH320AU

1" DRIVE AIR IMPACT WRENCH

Weight : 9.1kg

- Clutch hammer



Part #	Square Drive	Free Speed	Handle Style	Bolt Capacity	Air Pressure	Avg. Air Cons.	Weight
	Inch	RPM		mm	PSI	CFM	kg
NPK-NWH320AU	1"	4000	D Inside Trigger	39	85	17.7	9.1

1-1/2" DRIVE AIR IMPACT WRENCHES

NPK-NWH500

1-1/2" DRIVE AIR IMPACT WRENCH

Weight : 29.0kg

- Clutch hammer

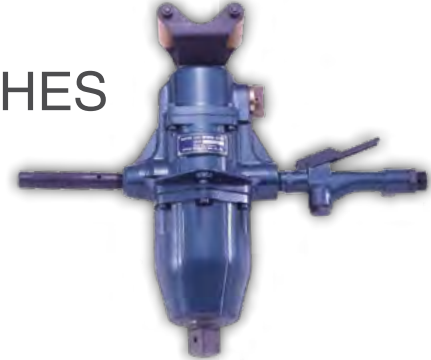

Part #	Square Drive	Free Speed	Handle Style	Bolt Capacity	Air Pressure	Avg. Air Cons.	Weight
	Inch	RPM		mm	PSI	CFM	kg
NPK-NWH500	1-1/2"	3500	Jumbo	52	85	42.4	29.0

1-3/4" DRIVE AIR IMPACT WRENCHES

NPK-NWH750

1-3/4" DRIVE AIR IMPACT WRENCH

Weight : 52.5kg

- Clutch hammer



Part #	Square Drive	Free Speed	Handle Style	Bolt Capacity	Air Pressure	Avg. Air Cons.	Weight
	Inch	RPM		mm	PSI	CFM	kg
NPK-NWH750	1-3/4"	2200	Jumbo	75	85	53.0	52.5

2-1/2" DRIVE AIR IMPACT WRENCHES

NPK-NWH75024

2-1/2" DRIVE AIR IMPACT WRENCH

Weight : 52.6kg

- Clutch hammer



Part #	Square Drive	Free Speed	Handle Style	Bolt Capacity	Air Pressure	Avg. Air Cons.	Weight
	Inch	RPM		mm	PSI	CFM	kg
NPK-NWH75024	2-1/2"	2200	Jumbo	75	85	53.0	52.6

AT-30A 3/8" DRIVE 90° ANGLE ATTACHMENT



Weight : 0.6kg

- Attaches to 3/8" drive impact wrenches

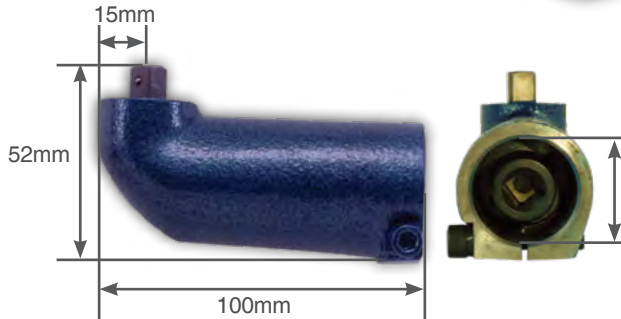

AT-40A 1/2" DRIVE 90° ANGLE ATTACHMENT



Weight : 1.3kg

- Attaches to 1/2" drive impact wrenches

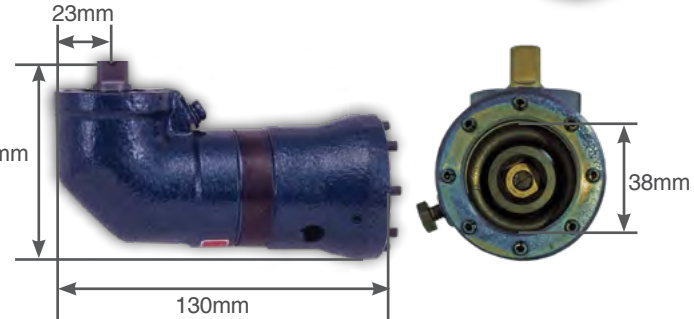

Part #	Description
AT-30A	3/8" Drive 90° Angle Attachment For Use With 3/8" Drive Impact Wrenches
AT-40A	1/2" Drive 90° Angle Attachment For Use With 1/2" Drive Impact Wrenches

AIR DRILLS

NPK-NRD6SA #1 JT DRIVE AIR DRILL

Free speed : 2800rpm

Weight : 0.8kg

- Non reversible type



NPK-NRD6PB(T) 3/8"-24UNF DRIVE AIR DRILL

Free speed : 2400rpm

Weight : 0.8kg

- Non reversible type



NPK-NRD10P WITHOUT CHUCK NPK-NRD10P(T) WITH CHUCK - PICTURED #2S JT DRIVE AIR DRILL

Free speed : 2000rpm

Weight : 1.1kg

- Non reversible type



NPK-NRD12PA(WC) #6 JT DRIVE AIR DRILL

Free speed : 1500rpm

Weight : 2.6kg

- Non reversible type



Part #	Drive	Free Speed RPM	Handle Style	Throttle Style	Chuck Supplied mm	Max. Output watt	Avg. Air Cons. CFM	Weight kg
NPK-NRD6SA	#1 JT	2800	Straight	Lever Throttle	-	370	17.7	0.8
NPK-NRD6PB(T)	3/8" -24UNF	2400	Pistol	Button	6.5	370	17.7	0.8
NPK-NRD10P	#2S JT	2000	Pistol	Button	10.0	440	19.4	1.1
NPK-NRD10P(T)	3/8" -24UNF	2000	Pistol	Button	10.0	440	19.4	1.1
NPK-NRD12PA(WC)	#6 JT	1500	Pistol	Button	13.0	530	23.0	2.6

NPK-NRD14R #1 MT DRIVE AIR DRILL

- Free speed : 1100rpm
Weight : 5.3kg
- Reversible type
 - Morse taper spindle
 - Roll throttle



NPK-NRD16R ROLL THROTTLE - PICTURED NPK-NRD16RLW SAFETY LEVER THROTTLE #2 MT DRIVE AIR DRILL

- Free speed : 900rpm
Weight : 5.5kg
- Reversible type
 - Morse taper spindle



NPK-NRD19R ROLL THROTTLE NPK-NRD19RD SPRING LOADED RETURN THROTTLE NPK-NRD19RLW SAFETY LEVER THROTTLE - PICTURED #2 MT DRIVE AIR DRILL

- Free speed : 750rpm
Weight : 5.5kg
- Reversible type
 - Morse taper spindle



NPK-NRD22R ROLL THROTTLE NPK-NRD22RD SPRING LOADED RETURN THROTTLE NPK-NRD22RLW SAFETY LEVER THROTTLE - PICTURED #2 MT DRIVE AIR DRILL

- Free speed : 600rpm
Weight : 5.5kg
- Reversible type
 - Morse taper spindle



NPK-NRD32LR ROLL THROTTLE - PICTURED NPK-NRD32LRLW SAFETY LEVER THROTTLE #3 MT DRIVE AIR DRILL

- Free speed : 380rpm
Weight : 10.3kg
- Reversible type
 - Morse taper spindle



Part #	Drive	Free Speed RPM	Handle Style	Throttle Style	Drill Capacity mm	Max. Output watt	Air Pressure PSI	Avg. Air Cons. CFM	Weight kg
NPK-NRD14R	#1 MT	1100	Jumbo	Roll Throttle	14	960	85	38.8	5.3
NPK-NRD16R	#2 MT	900	Jumbo	Roll Throttle	16	960	85	38.8	5.5
NPK-NRD16RLW	#2 MT	900	Jumbo	Safety Lever	16	960	85	38.8	5.5
NPK-NRD19R	#2 MT	750	Jumbo	Roll Throttle	19	960	85	38.8	5.5
NPK-NRD19RD	#2 MT	750	Jumbo	Spring Loaded Return	19	960	85	38.8	5.5
NPK-NRD19RLW	#2 MT	750	Jumbo	Safety Lever	19	960	85	38.8	5.5
NPK-NRD22R	#2 MT	600	Jumbo	Roll Throttle	22	960	85	38.8	5.5
NPK-NRD22RD	#2 MT	600	Jumbo	Spring Loaded Return	22	960	85	38.8	5.5
NPK-NRD22RLW	#2 MT	600	Jumbo	Safety Lever	22	960	85	38.8	5.5
NPK-NRD32LR	#3 MT	380	Jumbo	Roll Throttle	32	1470	85	49.4	10.3
NPK-NRD32LRLW	#3 MT	380	Jumbo	Safety Lever	32	1470	85	49.4	10.3

DIE GRINDERS

NPK-RG382 ALUMINIUM BODY - PICTURED
NPK-RG38CA COMPOSITE BODY
DIE GRINDER

Collet size : 6mm
 Max. output : 380 watt
 Weight : 0.6kg
 • Roll throttle style



NPK-RG38320
DIE GRINDER

Collet size : 1/4"
 Max. output : 380 watt
 Weight : 0.6kg
 • Safety lever throttle



NPK-RG383 ALUMINIUM BODY (PICTURED)
NPK-RG38CX COMPOSITE BODY
DIE GRINDER

Collet size : 6mm
 Max. output : 380 watt
 Weight : 0.6kg
 • Safety lever throttle



NPK-NHG65K ROLL THROTTLE - PICTURED
NPK-NHG65KLW SAFETY LEVER THROTTLE
LONG SHAFT DIE GRINDER

Collet size : 1/4"
 Max. output : 440 watt
 Weight : 1.3kg



NPK-NHG65LK ROLL THROTTLE
NPK-NHG65LKLW SAFETY LEVER THROTTLE - PICTURED
EXTRA LONG SHAFT DIE GRINDER

Collet size : 1/4"
 Max. output : 440 watt
 Weight : 1.6kg



Part #	Wheel Size	Throttle Style	Body Style	Free Speed RPM	Collet Size	Overall Length mm	Max. Output watt	Avg. Air Cons. CFM	Weight kg
NPK-RG382	25	Roll	Aluminium	22000	6mm	173	380	17.7	0.6
NPK-RG38CA	25	Roll	Composite	22000	6mm	173	380	17.7	0.6
NPK-RG38320	25	Safety Lever	Aluminium	22000	1/4"	178	380	17.7	0.6
NPK-RG383	25	Safety Lever	Aluminium	22000	6mm	178	380	17.7	0.6
NPK-RG38CX	25	Safety Lever	Composite	22000	6mm	183	380	17.7	0.6
NPK-NHG65K	32	Roll	Aluminium	18000	1/4"	309	440	19.4	1.3
NPK-NHG65KLW	32	Safety Lever	Aluminium	18000	1/4"	338	440	19.4	1.3
NPK-NHG65LK	32	Roll	Aluminium	18000	1/4"	509	440	19.4	1.6
NPK-NHG65LKLW	32	Safety Lever	Aluminium	18000	1/4"	538	440	19.4	1.6

STRAIGHT & CNS GRINDERS

NPK-NHG65D STANDARD SHAFT WITH ROLL THROTTLE - PICTURED

NPK-NHG65LD LONG SHAFT WITH ROLL THROTTLE
NPK-NHG65DLW STANDARD SHAFT WITH SAFETY LEVER
NPK-NHG65LDLW LONG SHAFT WITH SAFETY LEVER
STRAIGHT GRINDER

Max. wheel size : 65 x 13 x 9.5mm
 Free speed : 14600 RPM
 Max. output : 440 watt



NPK-NHG125 ROLL THROTTLE
NPK-NHG125LW SAFETY LEVER THROTTLE - PICTURED
STRAIGHT GRINDER

Max. wheel size : 125 x 19 x 12.7mm
 Free speed : 7500 RPM
 Max. output : 810 watt
 Weight : 3.2kg



NPK-NHG65G
CNS GRINDER

Max. wheel size : 65 x 26 x 9.5mm
 Free speed : 14000 RPM
 Max. output : 440 watt
 Weight : 1.3kg



NPK-NHG100A ROLL THROTTLE
NPK-NHG100ALW SAFETY LEVER THROTTLE - PICTURED
STRAIGHT GRINDER

Max. wheel size : 100 x 19 x 12.7mm
 Free speed : 9500 RPM
 Max. output : 650 watt
 Weight : 2.3kg



NPK-NHG150 ROLL THROTTLE - PICTURED
NPK-NHG150LW SAFETY LEVER THROTTLE
STRAIGHT GRINDER

Max. wheel size : 150 x 25 x 15.9mm
 Free speed : 6200 RPM
 Max. output : 960 watt
 Weight : 4.6kg



NPK-NHG75G
CNS GRINDER

Max. wheel size : 100 x 26 x 9.5mm
 Free speed : 6000 RPM
 Max. output : 480 watt
 Weight : 1.7kg



Part #	Max. Wheel Size	Throttle Style	Free Speed	Spindle Thread	Overall Length	Max. Output	Avg. Air Cons.	Weight
	mm		RPM		mm	watt	CFM	kg
NPK-NHG65D	65 x 13 x 9.5	Roll	14600	3/8" 16UNC	309	440	19.4	1.3
NPK-NHG65LD	65 x 13 x 9.5	Roll	14600	3/8" 16UNC	509	440	19.4	1.6
NPK-NHG65DLW	65 x 13 x 9.5	Safety Lever	14600	3/8" 16UNC	338	440	19.4	1.3
NPK-NHG65LDLW	65 x 13 x 9.5	Safety Lever	14600	3/8" 16UNC	538	440	19.4	1.6
NPK-NHG100A	100 x 19 x 12.7	Roll	9500	1/2" 12UNC	364	650	23.0	2.3
NPK-NHG100ALW	100 x 19 x 12.7	Safety Lever	9500	1/2" 12UNC	409	650	23.0	2.3
NPK-NHG125	125 x 19 x 12.7	Roll	7500	1/2" 12UNC	405	810	31.8	3.2
NPK-NHG125LW	125 x 19 x 12.7	Safety Lever	7500	1/2" 12UNC	453	810	31.8	3.2
NPK-NHG150	150 x 25 x 15.9	Roll	6200	5/8" 11UNC	437	960	38.8	4.6
NPK-NHG150LW	150 x 25 x 15.9	Safety Lever	6200	5/8" 11UNC	488	960	38.8	4.6
NPK-NHG65G	65 x 26 x 9.5	Roll	14000	-	309	440	19.4	1.3
NPK-NHG75G	100 x 26 x 9.5	Roll	6000	-	327	480	15.9	1.7

ANGLE GRINDERS

NPK-NAG1F ROLL THROTTLE - PICTURED
NPK-NAG1FLW04 SAFETY LEVER THROTTLE
ANGLE GRINDER

Max. wheel size :
100 x 6 x 15.9mm
Max. output : 630 watt
Weight : 1.5kg

**NPK-NAG70A** ROLL THROTTLE - PICTURED
NPK-NAG70ALW SAFETY LEVER THROTTLE
ANGLE GRINDER

Max. wheel size :
180 x 6 x 22mm
Max. output : 960 watt
Weight : 3.1kg
Features : Governor,
side handle

**NPK-NAG1F05** ROLL THROTTLE - PICTURED
NPK-NAG1FLW05 SAFETY LEVER THROTTLE
ANGLE GRINDER

Max. wheel size :
125 x 6 x 22mm
Max. output : 630 watt
Weight : 1.6kg

**NPK-NAG230E** ROLL THROTTLE - PICTURED
NPK-NAG230ELW SAFETY LEVER THROTTLE
ANGLE GRINDER

Max. wheel size :
230 x 6 x 22mm
Max. output : 960 watt
Weight : 4.4kg
Features : Governor,
side handle

**NPK-NAG2E** ROLL THROTTLE - PICTURED
NPK-NAG2ELW SAFETY LEVER THROTTLE
ANGLE GRINDER

Max. wheel size :
180 x 6 x 22mm
Max. output : 960 watt
Weight : 4.1kg
Features : Governor,
side handle



Part #	Max. Wheel Size	Throttle Style	Free Speed	Spindle Thread	Max. Output	Avg. Air Cons.	Weight
	mm		RPM		watt	CFM	kg
NPK-NAG1F	100 x 6 x 15.9	Roll	12700	-	630	24.0	1.5
NPK-NAG1FLW04	100 x 6 x 15.9	Safety Lever	12700	-	630	24.0	1.5
NPK-NAG1F05	125 x 6 x 22	Roll	12000	-	630	28.0	1.6
NPK-NAG1FLW05	125 x 6 x 22	Safety Lever	12000	-	630	28.0	1.6
NPK-NAG70A	180 x 6 x 22	Roll	7600	5/8" 11UNC	960	42.4	3.1
NPK-NAG70ALW	180 x 6 x 22	Safety Lever	7600	5/8" 11UNC	960	42.4	3.1
NPK-NAG2E	180 x 6 x 22	Roll	7600	5/8" 11UNC	960	42.4	4.1
NPK-NAG2ELW	180 x 6 x 22	Safety Lever	7600	5/8" 11UNC	960	42.4	4.1
NPK-NAG230E	230 x 6 x 22	Roll	5500	5/8" 11UNC	960	42.4	4.4
NPK-NAG230ELW	230 x 6 x 22	Safety Lever	5500	5/8" 11UNC	960	42.4	4.4

VERTICAL GRINDERS

NPK-NVG180SL VERTICAL GRINDER

Max. wheel size :
180 x 6 x 22mm
Max output : 1200watt
Weight : 3.8kg
• Governor



NPK-NVG230SLW VERTICAL GRINDER

Max. wheel size :
230 x 6 x 22mm
Max output : 1000watt
Weight : 4.2kg
• Governor



Part #	Wheel Size	Throttle Style	Free Speed	Spindle Thread	Max. Output	Avg. Air Cons.	Weight
	mm		RPM		watt	CFM	kg
NPK-NVG180SL	180 x 6 x 22	Lever	7100	5/8" 11UNC	1200	38.8	3.8
NPK-NVG230SLW	230 x 6 x 22	Safety Lever	5500	5/8" 11UNC	1000	38.8	4.2

SANDERS

NPK-NSG100 SANDER

Wheel size : 100mm
Free speed : 12000 RPM
Weight : 0.9kg
• Trigger throttle style



NPK-NSG180XB SANDER

Wheel size : 180mm
Free speed : 8500 RPM
Weight : 1.6kg
• Roll throttle style



NPK-NSG180XBLW SANDER

Wheel size : 180mm
Free speed : 8500 RPM
Weight : 2.1kg
• Safety lever throttle



Part #	Wheel Size	Throttle Style	Free Speed	Spindle Thread	Avg. Air Cons.	Weight
	mm		RPM	mm	CFM	kg
NPK-NSG100	100	Trigger	12000	16	14.1	0.9
NPK-NSG180XB	180	Roll	8500	22	23.0	1.6
NPK-NSG180XBLW	180	Safety Lever	8500	22	23.0	2.1

CHIPPING HAMMERS

NPK-AA00SP(H) CHIPPING HAMMER

Chisel shank :
11mm hex
Stroke : 45mm
Speed : 3800bpm
Weight : 2.1kg



NPK-AA1ASP(H) CHIPPING HAMMER

Chisel shank :
14.75mm hex
Stroke : 51mm
Speed : 2800bpm
Weight : 4.2kg



NPK-AA3SP(H) CHIPPING HAMMER

Chisel shank :
14.75mm hex
Stroke : 76mm
Speed : 2000bpm
Weight : 6.2kg



NPK-AA0SP(H) CHIPPING HAMMER

Chisel shank :
11mm hex
Stroke : 75mm
Speed : 3200bpm
Weight : 2.4kg



NPK-AA2SP(H) CHIPPING HAMMER

Chisel shank :
14.75mm hex
Stroke : 51mm
Speed : 2400bpm
Weight : 5.9kg



HEX CHISELS

Part #	Type	Width	Length	To Suit
N17501390	Flat Chisel	16mm	215mm	NPK-AA00SP, NPK-AA0SP
N17300087	Flat Chisel	16mm	350mm	NPK-AA00SP, NPK-AA0SP
N17501400	Point Chisel	-	220mm	NPK-AA00SP, NPK-AA0SP
N17300075	Point Chisel	-	350mm	NPK-AA00SP, NPK-AA0SP
N17300822	Wide Chisel w Spring	40mm	215mm	NPK-AA00SP, NPK-AA0SP
N17501910	Flat Chisel	20mm	300mm	NPK-AA1SP, NPK-AA2SP, NPK-AA3SP
N17300290	Flat Chisel	20mm	500mm	NPK-AA1SP, NPK-AA2SP, NPK-AA3SP
N17501920	Point Chisel	-	300mm	NPK-AA1SP, NPK-AA2SP, NPK-AA3SP
N17300244	Point Chisel	-	500mm	NPK-AA1SP, NPK-AA2SP, NPK-AA3SP
N17300824	Wide Chisel w Spring	72mm	300mm	NPK-AA1SP, NPK-AA2SP, NPK-AA3SP

Part #	Chisel Shank	Piston Diameter	Speed	Stroke	Handle Style	Avg. Air Cons.	Weight
	mm	mm	bpm	mm		CFM	kg
NPK-AA00SP(H)	11 hex	18	3800	45	Open D	10.6	2.1
NPK-AA0SP(H)	11 hex	18	3200	75	Open D	12.4	2.4
NPK-AA1ASP(H)	14.75 hex	24	2800	51	D Handle	14.1	4.2
NPK-AA2SP(H)	14.75 hex	28	2400	51	D Handle	17.7	5.9
NPK-AA3SP(H)	14.75 hex	28	2000	76	D Handle	17.7	6.2

NEW KELENS



- NPK-NNK250 ROLL THROTTLE
- NPK-NNK250L LEVER THROTTLE
- NPK-NNK500 ROLL THROTTLE - PICTURED
- NPK-NNK500L LEVER THROTTLE
- NPK-NNK1000 ROLL THROTTLE
- NPK-NNK1000L LEVER THROTTLE

Chisel shank : 12.7mm Square
Speed : 4000 BPM

NEW KELEN FLAT CHISELS

Part #	Description
N17510080	Flat Chisel, 38mm X 200mm T/S New Kelens
N17300676	Flat Chisel, 38mm X 300mm T/S New Kelens
N17510100	Flat Chisel, 60mm X 200mm T/S New Kelens
N17300689	Flat Chisel, 60mm X 300mm T/S New Kelens

Part #	Overall Length	Chisel Shank	Piston Diameter	Speed	Stroke	Throttle Style	Avg. Air Cons.	Weight
	mm	mm	mm	bpm	mm		CFM	kg
NPK-NNK250	514	12.7mm Hex	25.4	4000	23	Roll	15.9	3.4
NPK-NNK250L	571	12.7mm Hex	25.4	4000	23	Lever	15.9	4.5
NPK-NNK500	744	12.7mm Hex	25.4	4000	23	Roll	15.9	4.2
NPK-NNK500L	801	12.7mm Hex	25.4	4000	23	Lever	15.9	5.3
NPK-NNK1000	1284	12.7mm Hex	25.4	4000	23	Roll	15.9	5.8
NPK-NNK1000L	1341	12.7mm Hex	25.4	4000	23	Lever	15.9	6.9

NEEDLE SCALERS

NPK-NHR00 NEEDLE SCALER

Speed : 6500 BPM
 Weight : 0.82kg
 Needles : 3mm diameter x 7



NPK-NHR20 NEEDLE SCALER

Speed : 4000 BPM
 Weight : 2.1kg
 Needles : 3mm diameter x 12



Part #	Needle Diameter	Needle Qty	Speed	Piston Diameter	Stroke	Length	Avg. Air Cons.	Weight
	mm		BPM	mm	mm	mm	CFM	kg
NPK-NHR00	3	7	6500	14	12	216	7.1	0.82
NPK-NHR20	3	12	5500	20	27.5	245	7.1	2.1

FLUX SCALING HAMMERS

NPK-NF00 FLUX SCALING HAMMER

Chisel shank : 10mm diameter
Speed : 6500 BPM
Weight : 0.55kg

- Cap chisel holder style
- 12mm chisels available 120, 150, 200 & 300mm lengths



NPK-NF20 FLUX SCALING HAMMER

Chisel shank : 9mm diameter
Speed : 5000 BPM
Weight : 0.88kg

- Cap chisel holder style
- Chisel not included
- 9mm chisels available 130, 155, 200, 250 & 300mm lengths



NPK-NF0 FLUX SCALING HAMMER

Chisel shank : 10mm diameter
Speed : 5500 BPM
Weight : 0.8kg

- Cap chisel holder style
- 12mm chisels available 120, 150, 200 & 300mm lengths



NPK-NF1SH FLUX SCALING HAMMER

Chisel shank : 12.7mm square
Speed : 4800 BPM
Weight : 0.94kg

- Slide ball retainer style
- 35mm angle chisels available 155 & 210mm lengths
- 30mm flat chisels available 155 & 210mm lengths



NPK-NFB25H FLUX SCALING HAMMER

Chisel shank : 12.7mm square
Speed : 4000 BPM
Weight : 2.0kg

- Slide ball retainer style
- 19.5mm chisels available 200 & 300mm lengths



N17509980 FLAT CHISEL

19.5 x 200mm

N17300666 FLAT CHISEL

19.5 x 300mm



Part #	Chisel Shank mm	Piston Diameter mm	Speed BPM	Stroke mm	Avg. Air Cons. CFM	Weight kg
NPK-NF00	10 Round	14	6500	12	8.1	0.55
NPK-NF0	10 Round	18	5500	18	8.1	0.80
NPK-NF20	9 Square	20	5000	17	5.3	0.88
NPK-NF1SH	12.7 Square	22	4800	22	8.8	0.94
NPK-NFB25H	12.7 Square	25.4	4000	23	19.4	2.00
Part #						
N17509980	Flat Chisel, 19.5mm x 200mm To Suit NPK-NFB25H					
N17300666	Flat Chisel, 19.5mm x 300mm To Suit NPK-NFB25H					

AUTO CHISELERS

NPK-NBH400 AUTO CHISELER

Chisel shank : 10.2mm round
Stroke : 95mm
Speed : 1600BPM



NPK-NBH600A AUTO CHISELER

Chisel shank : 12.7mm round
Stroke : 68mm
Speed : 1500BPM

- Built in power regulator



Chisels to suit NPK-NBH400 & NPK-NBH600A. Contact ITM for part numbers and pricing.

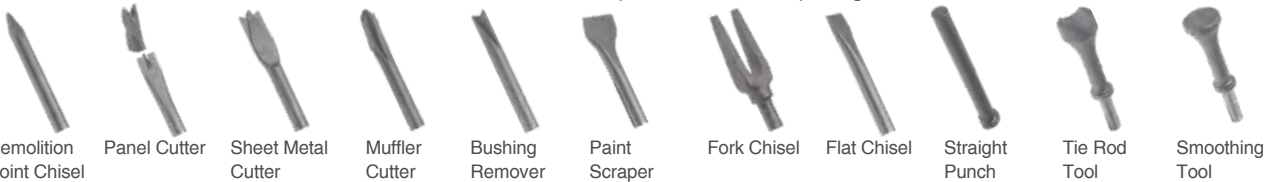

Part #	Chisel Shank mm	Piston Diameter mm	Speed BPM	Stroke mm	Avg. Air Cons. CFM	Weight kg
NPK-NBH400	10.2 round	13	1600	95	3.9	1.4
NPK-NBH600A	12.7 round	19	1500	68	5.7	2.0
Part #	Description					
NPK-NA60	Needle Scaler Attachment To Suit NPK-NBH600A					

SAND RAMMERS

NPK-B00A SAND RAMMER

Rubber butt diameter : 40mm
Stroke : 60mm
Weight : 2.1kg



NPK-B0A SAND RAMMER

Rubber butt diameter : 50mm
Stroke : 60mm
Weight : 3.1kg



NPK-B1A SAND RAMMER

Rubber butt diameter : 64mm
Stroke : 110mm
Weight : 5.4kg



NPK-F00 SAND RAMMER

Rubber butt diameter : 40mm
Stroke : 60mm
Weight : 2.1kg



NPK-F0 SAND RAMMER

Rubber butt diameter : 50mm
Stroke : 60mm
Weight : 3.1kg



NPK-F1 SAND RAMMER

Rubber butt diameter : 64mm
Stroke : 110mm
Weight : 6.8kg



NPK-F2 SAND RAMMER

Rubber butt diameter : 70mm
Stroke : 120mm
Weight : 9.0kg



NPK-F4 SAND RAMMER

Rubber butt diameter : 87mm
Stroke : 120mm
Weight : 12.0kg



Part #	Butt Diameter	Piston Diameter	Stroke	Overall Length	Throttle style	Avg. Air Cons.	Weight
	mm	mm	mm	mm		CFM	kg
NPK-B00A	40	18.0	60	337	Lever	7.1	2.1
NPK-B0A	50	22.0	60	380	Lever	8.8	3.1
NPK-B1A	64	25.4	110	502	Lever	14.1	5.4
NPK-F00	40	18.0	60	390	Roll	7.1	2.1
NPK-F0	50	22.0	60	435	Roll	8.8	3.1
NPK-F1	64	25.4	110	1098	Lever	14.1	6.8
NPK-F2	70	32.0	120	1134	Lever	19.4	9.0
NPK-F4	87	40.0	120	1136	Lever	30.0	12.0

HOISTS

Lift speeds shown are maximum lift speed when lifting maximum load. NPK Hoists have built in speed adjuster for ease of lift speed variation. Pull Cord Type standard. Optional Pendant Control available

NPK-RHL250 PULL CORD CONTROL - PICTURED NPK-RHL250P PENDANT CONTROL HOIST

Capacity : 250kg
Lift speed : 27m/min
Weight : 16.0kg



NPK-RHL1000 PULL CORD CONTROL - PICTURED NPK-RHL1000P PENDANT CONTROL HOIST

Capacity : 1000kg
Lift speed : 5.7m/min
Weight : 22.0kg



NPK-RHL500 PULL CORD CONTROL NPK-RHL500P PENDANT CONTROL - PICTURED HOIST

Capacity : 500kg
Lift speed : 12.6m/min
Weight : 16.0kg



NPK-RHL2800P HOIST

Capacity : 2800kg
Lift speed : 2.2m/min
Weight : 63.0kg
• Control type : Pendant



Part #	Capacity	Standard Chain	Standard Lift	Lift Speed	Control Type	Avg. Air Cons.	Weight
	kg	m	m	m/min		CFM	kg
NPK-RHL250	250	3.5	3	27	Pull Cord	45.9	16.0
NPK-RHL250P	250	3.5	3	27	Pendant	45.9	16.0
NPK-RHL500	500	3.5	3	12.6	Pull Cord	45.9	16.0
NPK-RHL500P	500	3.5	3	12.6	Pendant	45.9	16.0
NPK-RHL1000	1000	6.7	3	5.7	Pull Cord	45.9	22.0
NPK-RHL1000P	1000	6.7	3	5.7	Pendant	45.9	22.0
NPK-RHL2800P	2800	7.5	3	2.2	Pendant	60.0	63.0
Part #	Description						
NPK-PCU1000	2m Pendant Control Unit to suit NPK-RHL250/500/1000						
N28602057	Replacement Chain per metre t/s NPK-RHL250/500/1000						
N28602162	Replacement Chain per metre t/s NPK-RHL2800P						
N28603025	Chain Bucket, Holds Up To 16m Chain, To Suit NPK-RHL250/500/1000						
N28603004	Chain Bucket, Holds Up To 26m Chain, To Suit NPK-RHL250/500/1000						
N28603005	Chain Bucket, Holds Up To 40m Chain, To Suit NPK-RHL250/500/1000						



By Nippon Pneumatic MFG Co Japan

Efficient, high speed material handling

NPK air hoists are engineered to provide high lifting speeds and accurate control. Lightweight, compact design for use in a stationary position, but can also be quickly moved to another location. Air hoists are extremely useful in hazardous environments where electrical hoists are prohibited. Features external brake adjustment, exhaust muffler, built-in lubricator and swivel mounted air inlet.

Extra rugged construction

Durable construction for constant, heavy-duty use. Designed for fast moving production assembly operations and heavy manufacturing industries.

Overload-proof air motor for a made safety margin

The rotary vane air motor is completely enclosed. Motor is unaffected by fumes, dirt or heat. Motor and controls can withstand constant stopping and sudden starting. Can be overloaded or stalled without damage to the hoist. Motor is inherently self-cooling and cannot be burned out.

Safety hooks and automatic limit stops

Top and bottom books have safety snaps and hoist has automatic limit stops to prevent over-travel.

Variable speed control

Operator can choose any speed from the slowest creep to lull throttle. The heaviest loads can be positioned quickly and accurately, or raised rapidly. Features an external screw adjustment for lift and descent speeds.

Pendant type control

Leaves the operator one hand free to guide the load with precise control. Preferred compact design and easy handling.



Model NPK-PCU1000 With guard (Included with all pendant control hoists) **Model NPK-PCU1000** (Shown without guard for detail)

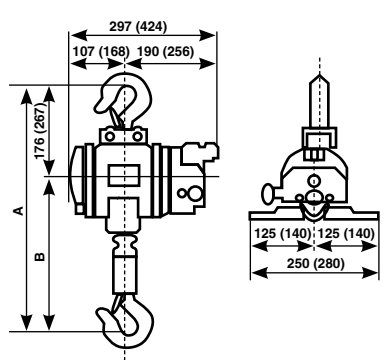

"(") marks are for NPK-RHL2800

Part #	Dimension A	Dimension B
NPK-RHL250	461	285
NPK-RHL500	461	285
NPK-RHL1000	517	341
NPK-RHL2800	766	499

Adjustment for up and down speed

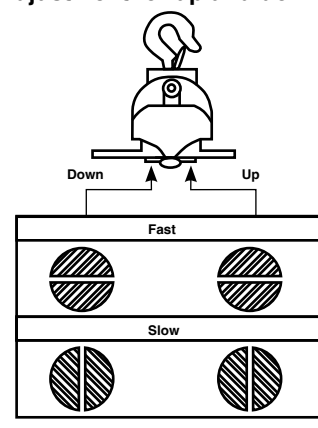

Up and down speed of the hoists can be set quite freely by the speed adjuster.

NPK-RHL500 Speed range of speed adjuster

Load (kgf)	Air Pressure (MPa)	Lifting Speed (m/min)	Down Speed (m/min)
125	0.4	14.2 ~ 24.5	3.8 ~ 27.3
	0.5	16.9 ~ 27.9	3.9 ~ 28.6
	0.6	17.6 ~ 31.6	3.9 ~ 29.3
250	0.4	9.8 ~ 18.8	6.2 ~ 30.8
	0.5	12.2 ~ 23.1	5.8 ~ 34.3
	0.6	13.8 ~ 25.5	5.6 ~ 32.4
375	0.4	5.6 ~ 12.6	26.1 ~ 38.7
	0.5	8.6 ~ 16.2	22.1 ~ 38.7
	0.6	10.3 ~ 19.7	18.2 ~ 35.3
500	0.4	-	-
	0.5	4.2 ~ 11.4	30.0 ~ 42.9
	0.6	6.9 ~ 14.0	29.3 ~ 40.0

NPK-RHL250 Speed - range double of the above mentioned range

NPK-RHL1000 Speed - half of the above mentioned range

PNEUMATIC TOOLS

NPK-NRT8P TAPPER

Drive : #1 JT
Free speed : 1700 RPM
Max. output : 400 watt
Weight : 1.2kg
• Reversible



Part #	Drive	Handle Style	Free Speed	Chuck Supplied	Max. Output	Avg. Air Cons.	Weight
			RPM	mm	watt	CFM	kg
NPK-NRT8P	#1 JT	Pistol Grip	1700	8	400	19.4	1.2

NPK-SD4 SCREW DRIVER

Free speed : 2000 RPM
Torque range : 1 - 3.4 Nm (0.7 - 2.5 FT-LB)
Weight : 0.6kg
• Cushion clutch type
• Operated by simply pushing against screw
• Torque adjustable



Part #	Hex Shank	Free Speed	Torque Range		Bolt Capacity	Avg. Air Cons.	Weight
	mm	rpm	Nm	ft-lb	mm	CFM	kg
NPK-SD4	6.35	2000	1 - 3.4	0.7 - 2.5	4	7.1	0.6

NPK-MS30 STANDARD PISTONS - PICTURED NPK-MS30(C) CARBIDE PISTONS SCALING HAMMER

Weight : 3.2kg
• Triple head

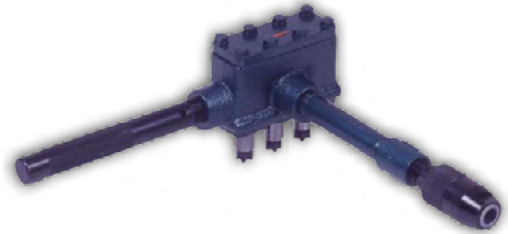

Part #	Piston Diameter	Piston Type	Speed	Stroke	Avg. Air Cons.	Weight
	mm		BPM	mm	CFM	kg
NPK-MS30	22	Standard	7000	10	19.4	3.2
NPK-MS30(C)	22	Carbide	7000	10	19.4	3.2

NPK-DIG9 DIGGER

Chisel shank : 22.2mm Hex
Speed : 1500bpm
Weight : 8.8kg



NPK-CB20A DIGGER

Chisel shank : 30mm Round
Speed : 38.0bpm
Weight : 20.0kg



NPK-CB30B DIGGER

Chisel shank : 35mm Round
Speed : 45.0bpm
Weight : 28.5kg



Part #	Chisel Shank	Piston Diameter	Speed	Stroke	Avg. Air Cons.	Weight
	mm	mm	BPM	mm	CFM	kg
NPK-DIG9	22.2 Hex	42.8	1500	63.5	38.8	8.8
NPK-CB20A	30 Round	38.0	950	150	42.4	20.0
NPK-CB30B	35 Round	45.0	850	165	49.4	28.5

NPK-JAC3 SUCTION CLEANER

Suction : 17.5 KPa
Weight : 0.77kg



Part #	Suction	Hose Diameter	Air Pressure	Avg. Air Cons.	Weight
	KPa	mm	psi	CFM	kg
NPK-JAC3	17.5	30	85	21.2	0.77

NPK-DAC11 DIAMOND CUTTER

Wheel size : 54 x 1 x 10mm
Free speed : 13000rpm
Weight : 1.7kg



Part #	Wheel Size	Free Speed	Overall Length	Throttle Style	Avg. Air Cons.	Weight
	mm	rpm	mm		CFM	kg
NPK-DAC11	54 x 1 x 10	13000	298	Lever	15.9	1.7

NPK-NRV5223 VIBRATOR

Speed : 9400VPM
Weight : 2.5kg
• Rotary type



Part #	Speed	Bolt Size	Bolt Centres	Avg. Air Cons.	Weight
	VPM	mm	mm	CFM	kg
NPK-NRV5223	9400	12	130	17.7	2.5

N-OILER AIR TOOL OILER



Part #	Description
N-OILER	3/8" Swivel Inline Oiler

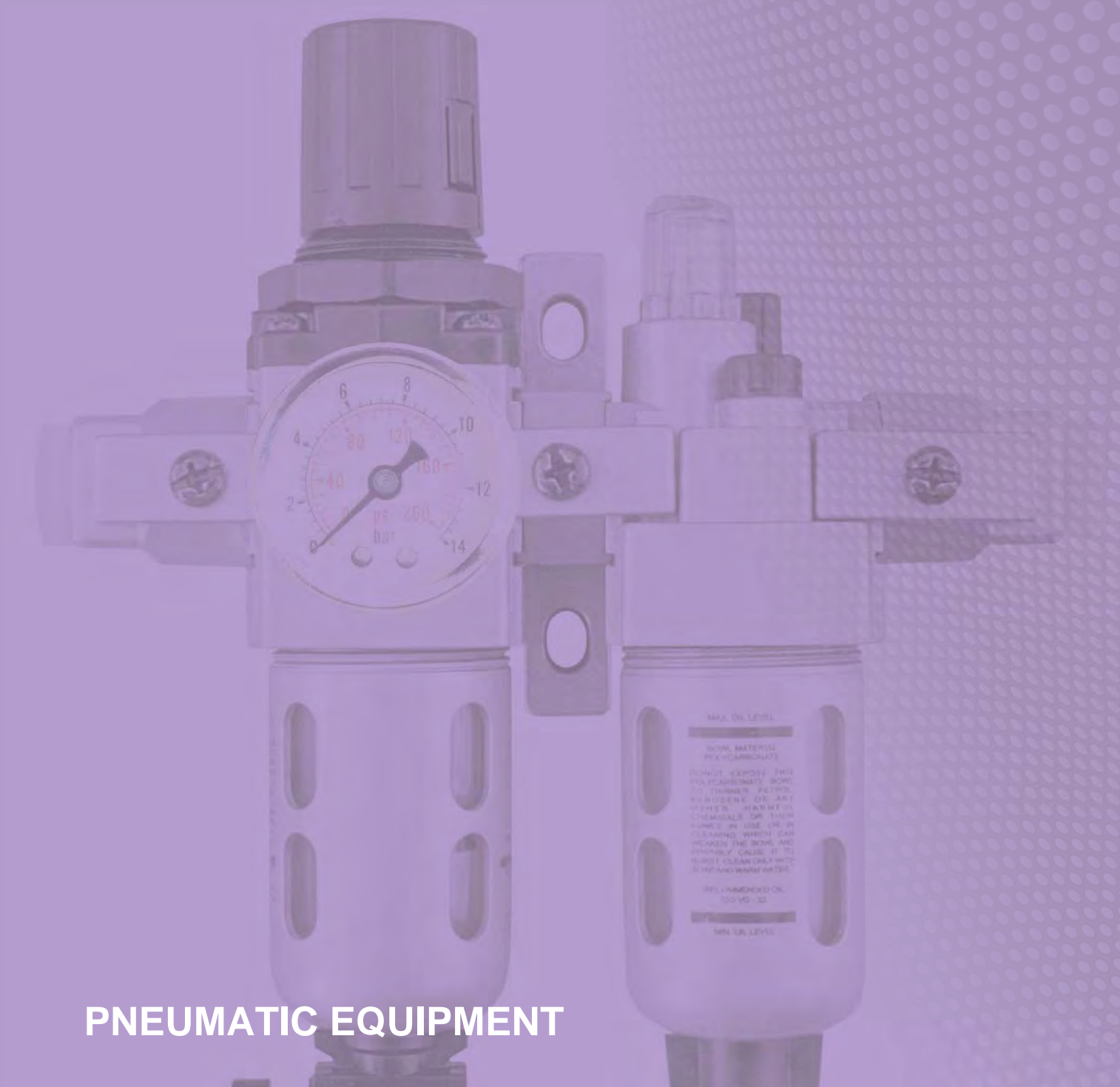

PNEUMATIC EQUIPMENT

Spray Equipment	311	Pro Series Air Blow Guns - Groz	316
Suction Feed Guns	311	Filters & Regulators	320
Gravity Feed Guns	312	Air Line Couplers	323
Touch Up Guns	313	Air Line Manifolds	324
Pressure Pot Outfits	313	Air Hoses & Accessories	326
Air Blow Guns - M7	314	Push Fit Fittings	328

SPRAY EQUIPMENT

For over 40 years Rich Star has been designing and manufacturing high quality spray guns for a wide range of general & industrial applications. Star guns deliver an optimum result and superior atomisation, at an affordable price. A full range of nozzle sizes are available, as are backup spare parts.

Nozzle Size	Application
1.2mm	Stain, detail touch up & 2-pack top coat
1.3mm	2-Pack top coat, enamel & polyurethane
1.4 - 1.5mm	2-Pack base coat, fine finish top coat, enamel, acrylic lacquer & polyurethane
1.6mm	High solid, enamel & 2-pack base coat
1.8mm	Acrylic lacquer, primer filler, enamel, furniture lacquer, industrial enamel & primer
2.0mm	Acrylic lacquer, furniture lacquer, primer filler, industrial enamel, primer & metallic
2.5mm	Primer, spray putty, industrial enamel, heavy primer & sprayable glue
3.0mm	Primer, zinc, polyester, gel coat, house paint & coating requiring quick coverage (via pressure pot system)

SUCTION FEED GUNS

S770-S SERIES

- Pot size : 1000ml
Includes : Gun, pot, stainless steel nozzle and needle
- A popular conventional high pressure spray gun that provides extremely fine atomisation for the D.I.Y. person to the professional
 - For applications such as automotive spraying



Part No.	Nozzle Size	Required Pressure	Air Consumption	Spray Pattern
S770-11S	1.5mm	50-70PSI	6.89CFM	235mm
S770-21S	1.7mm	50-70PSI	7.77CFM	245mm
S770-31S	2.0mm	50-70PSI	8.83CFM	260mm
S770-41S	2.5mm	50-70PSI	11.66CFM	275mm
S770-51S	3.0mm	50-70PSI	12.2CFM	275mm

GENERAL PURPOSE "SMP" SERIES

- Pot size : 1000ml
Air consumption : 11.0 - 13.0 CFM (310 - 365 LPM)
Includes : Gun, pot, stainless steel nozzle and needle
- Achieves large fan, premium finishing results, fast application speed and 65% transfer efficiency at 29PSI
 - Ideal for car refinishing, high class furniture and industrial use



Part No.	Nozzle Size	Air Inlet Pressure	Pattern Width
SG-SMP106FS-014	1.4mm	29 PSI	270 - 320mm
SG-SMP106FS-016	1.6mm	29 PSI	270 - 320mm
SG-SMP106FS-018	1.8mm	29 PSI	270 - 320mm
SG-SMP106FS-020	2.0mm	29 PSI	270 - 320mm
SG-SMP106FS-025	2.5mm	29 PSI	270 - 320mm

PROFESSIONAL "EVO T" SERIES

- Pot size : 1000ml
Air consumption : 12.0 - 14.0 CFM (340 - 395 LPM)
Includes : Gun, pot, stainless steel nozzle and needle
- EVO-T Patented air cap design providing ultra fine finish & excellent transfer efficiency exceeding 72% at 15PSI
 - Improved ergonomics providing perfect body balance & handling for manoeuvrability
 - Stronger forged body with colour anodisation throughout fluid passage
 - Ideal for waterborne painting procedures



Part No.	Nozzle Size	Air Inlet Pressure	Pattern Width
SG-EVO106FS-012	1.2mm	15 - 19 PSI	230 - 270mm
SG-EVO106FS-014	1.4mm	15 - 19 PSI	230 - 270mm
SG-EVO106FS-018	1.8mm	15 - 19 PSI	230 - 270mm
SG-EVO106FS-020	2.0mm	15 - 19 PSI	230 - 270mm
SG-EVO106FS-025	2.5mm	15 - 19 PSI	230 - 270mm

GRAVITY FEED GUNS

GRAVITY FEED SPRAY GUN

Pot size : 600ml

Includes : Gun, pot, stainless steel nozzle and needle

- Provides constant paint flow at lower pressures, and extremely fine atomisation for suitable professional applications.



Part No.	Nozzle Size	Required Pressure	Air Consumption	Spray Pattern
S106-141G	1.4mm	50-70PSI	6.5CFM	250mm
S106-201G	2mm	50-70PSI	8.8CFM	270mm
S106-251G	2.5mm	50-70PSI	10CFM	270mm
S106-281G	2.8mm	50-70PSI	11CFM	270mm

H.V.L.P. GRAVITY FEED SPRAY GUN

Pot size : 600ml

Includes : Gun, pot, stainless steel nozzle and needle

- A high performance low pressure centre-post gravity feed spray gun with low air consumption, a minimum of 65% transfer efficiency & superior atomisation.



Part No.	Nozzle Size	Required Pressure	Air Consumption	Spray Pattern
SV106-G15	1.5mm	41-44PSI	9-11CFM	240mm
SV106-G19	1.9mm	41-44PSI	9-11CFM	265mm

GENERAL PURPOSE "SMP" SERIES

Pot size : 600ml

Air consumption :
10.5 - 12.5 CFM (300 - 355 LPM)

Includes : Gun, pot, stainless steel nozzle and needle

- Achieves large fan, premium finishing results, fast application speed and 65% transfer efficiency at 29PSI
- Ideal for car refinishing, high class furniture and industrial use



Part No.	Nozzle Size	Air Inlet Pressure	Pattern Width
SG-SMP106FG-013	1.3mm	29 PSI	280 - 330mm
SG-SMP106FG-014	1.4mm	29 PSI	280 - 330mm
SG-SMP106FG-015	1.5mm	29 PSI	280 - 330mm
SG-SMP106FG-018	1.8mm	29 PSI	280 - 330mm
SG-SMP106FG-020	2.0mm	29 PSI	280 - 330mm
SG-SMP106FG-025	2.5mm	29 PSI	280 - 330mm

PROFESSIONAL "EVO T" SERIES

Air consumption :

11.5 - 13.5 CFM (325 - 380 LPM)

Includes : Gun, pot, stainless steel nozzle and needle

- EVO-T Patented air cap design providing ultra fine finish & excellent transfer efficiency exceeding 72% at 15PSI
- Improved ergonomics providing perfect body balance & handling for manoeuvrability
- Stronger forged body with colour anodization throughout fluid passage
- Ideal for waterborne painting procedures



Part No.	Nozzle Size	Air Inlet Pressure	Pattern Width	Pot Size
SG-EVO106FG-013	1.3mm	15 - 19 PSI	280 - 285mm	600ml
SG-EVO106FG-014	1.4mm	15 - 19 PSI	280 - 285mm	600ml
SG-EVO106FG-018	1.8mm	15 - 19 PSI	280 - 285mm	600ml
SG-EVO106FG-020	2.0mm	15 - 19 PSI	280 - 285mm	600ml
SG-EVO106FG-025	2.5mm	15 - 19 PSI	280 - 285mm	600ml

TOUCH UP GUNS

PROFESSIONAL "EVO T" SERIES TOUCH UP GUN

Air consumption :
3.0 - 4.5 CFM (85 - 125 LPM)
Includes : 250mL Gun, pot, stainless
steel nozzle and needle

- EVO-T Patented air cap design providing ultra fine finish & excellent transfer efficiency exceeding 72% at 15PSI
- Improved ergonomics providing perfect body balance & handling for manoeuvrability
- Stronger forged body with colour anodization throughout fluid passage
- Ideal for waterborne painting procedures



Part No.	Nozzle Size	Air Inlet Pressure	Pattern Width	Pot Size
SG-EVO106TFG-012	1.2mm	15 - 19 PSI	100 - 150mm	250ml

GENERAL PURPOSE GRAVITY FEED TOUCH UP GUN

Includes : Gun, pot, stainless steel nozzle and needle

- Ideal for custom designing, auto touch-up work, detail spray work and stencil spraying



Part No.	Nozzle Size	Required Pressure	Spray Pattern	Pot Capacity
S106T-05G	0.5mm	30-50 PSI	95mm	130ml
S106T-08G	0.8mm	30-50 PSI	95mm	130ml
S106T-10G	1.0mm	30-50 PSI	95mm	130ml

GENERAL PURPOSE SUCTION FEED TOUCH UP GUN

Includes : Gun, pot, stainless steel nozzle and needle

- Ideal for custom designing, auto touch-up work, detail spray work and stencil spraying



Part No.	Nozzle Size	Required Pressure	Spray Pattern	Pot Capacity
SJ108	1.4mm	30-50 PSI	120mm	250ml

PRESSURE POT OUTFITS

Complete with gun, hoses, pot, regulator, stainless steel nozzle and needle. General purpose high volume spray outfits are ideal for spraying on large surfaces and mass production. For use with all conventional enamels, lacquers and sealers.



Part No.	Nozzle Size	Required Pressure	Spray Pattern	Pot Capacity	Hose Length
S770-2QP	1.2mm	10-60 PSI	360mm	2 Litre	2m
S770-10QP	1.2mm	10-60 PSI	360mm	10 Litre	3.5m
Part No.	Description				
S770-2QPGUN	Gun Only To Suit 2L & 10L Spray Outfits				
S770-2QPHOSE	2 Metre Hose To Suit S770-2QP				
S770-10QPHOSE	3.5 Metre Hose To Suit S770-10QP				



AIR BLOW GUNS

STANDARD AIR BLOW GUNS



Air Inlet : 1/4"

M7-JC405
125mm



M7-JC424
610mm



M7-JC410
250mm



M7-JC435
890mm



M7-JC412
305mm



Part No.	Nozzle Length		Working Pressure	Air Inlet	Max Pressure	Avg. Air Consumption (1/4" Hose)	Avg. Air Consumption (3/8" Hose)	Net Weight	Sound Pressure
	mm	inch							
M7-JC405	125	5"	75-120	1/4"	150	13	15	0.11	90
M7-JC410	250	10"	75-120	1/4"	150	13	15	0.12	90
M7-JC412	305	12"	75-120	1/4"	150	13	15	0.13	90
M7-JC424	610	24"	75-120	1/4"	150	13	15	0.14	90
M7-JC435	890	35"	75-120	1/4"	150	13	15	0.25	90

M7-JC0424 AIR BLOW GUN MERCHANDISERS

Open dimensions: 480mm (W) x 300mm (D) x 360mm (H)

Includes:

- 8x 125mm M7 Blow Guns M7-JC405
- 8x 250mm M7 Blow Guns M7-JC410
- 8x 305mm M7 Blow Guns M7-JC412



M7-JC0415 AIR BLOW GUN MERCHANDISER

Open dimensions: 220mm (W) x 220mm (D) x 365mm (H)

Includes:

- 15x 125mm M7 Blow Guns M7-JC405



Part No.	Description
M7-JC0424	Air Blow Gun Merchandiser, 24 Pce

Part No.	Description
M7-JC0415	Air Blow Gun Merchandiser, 15 Pce



M7-JC504
HEAVY DUTY STRAIGHT
NOZZLE AIR BLOW GUN

Air Inlet : 1/4" Metal Fitting
 Net Weight : 0.16kg
 Nozzle Length : 4" / 100mm
 • Durable body



M7-JC510
HEAVY DUTY STRAIGHT NOZZLE
AIR BLOW GUN EXTENDED REACH

Air Inlet : 1/4" Metal Fitting
 Net Weight : 0.19kg
 Nozzle Length : 10" / 250mm
 • Durable body



M7-JC507
EXTENDABLE SWIVEL AIR BLOW GUN

Air Inlet : 1/4" Metal Fitting
 Net Weight : 0.22kg
 Nozzle Length : 6-1/2" to 12" / 165 to 305mm
 • Tube extends and retracts for optimal positioning
 • Nozzle angle rotates
 • Durable body

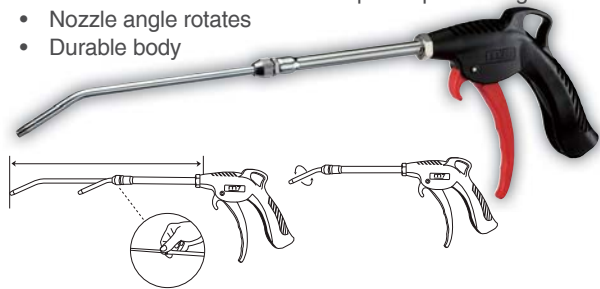

M7A-JC291 (Bulk)
M7A-JC292 (Individual hang pack)
STANDARD SAFETY TIP

For use with M7-JC3 series
 and M7-JC5 series blow guns



M7-JC640 1016mm
M7-JC680 2032mm
SUPER AIR BLOW GUN

Air Inlet : 1/4" Metal Fitting
 Net Weight : 0.34kg



Part No.	Nozzle Length		Working Pressure	Air Inlet	Max Pressure	Avg. Air Consumption (1/4" Hose)	Avg. Air Consumption (3/8" Hose)	Net Weight	Sound Pressure
	inch	mm							
M7-JC504	4"	100	90-120	1/4"	220	13	15	0.16	80
M7-JC510	10"	250	90-120	1/4"	220	13	15	0.19	80
M7-JC507	6-1/2" to 12"	165 to 305	90-120	1/4"	220	13	15	0.22	75
M7-JC640	40"	1016	75-120	1/4"	150	13	15	0.34	90
M7-JC680	80"	2032	75-120	1/4"	150	13	15	0.64	90
Part No.	Description								
M7A-JC291	Safety Tip To Suit 304/310/313/320/340/507/510 Blow Gun (Supplied As A Bulk Item)								
M7A-JC292	Safety Tip To Suit 304/310/313/320/340/507/510 Blow Gun (Supplied In Individual Hang Pack)								

- Magnetic Base Drilling Machines
- Cutting Tools
- Clamps
- Engineer's Tools
- Sharpening Machines
- Metal Cutting Saws
- Drilling Machines
- Bevelling Machines & Welding Carriages
- Punches & Shears
- Grinding Machines
- Fans & Ventilators
- Workshop Storage
- M7 Airtools
- NPK Airtools
- Pneumatic Products





PROFESSIONAL AIR BLOW GUNS

The Professional Series air blow guns below feature:

- Corrosion resistant stainless steel metal parts
- 1/4" Brass threaded air inlet
- High quality impact & weather resistant nylon body
- Variable flow trigger with moulded rubber grip
- Silenced operation with noise level below 80dB
- 50 to 235 PSI operating pressure
- -10° to +70° operating temperature



Part No.	Code	Description
GZ-61000	ABG-1	Professional Air Blow Gun

SAFETY BLOW GUN

All of the professional features above, plus:

- Snub nose soft rubber tip
- Safety model



Part No.	Code	Description
GZ-61001	ABG-2	Safety Blow Gun

EXTENDED REACH BLOW GUNS

All of the professional features above, plus:

- Vented tip to prevent pressure exceeding 30PSI in case of blockage
- 330 to 990mm length
- Safety model

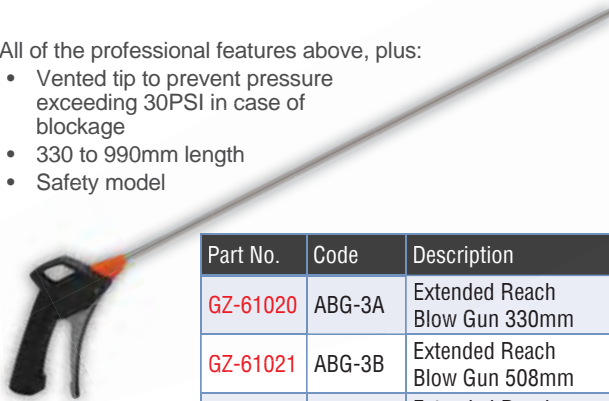

Part No.	Code	Description
GZ-61020	ABG-3A	Extended Reach Blow Gun 330mm
GZ-61021	ABG-3B	Extended Reach Blow Gun 508mm
GZ-61022	ABG-3C	Extended Reach Blow Gun 990mm

GENERAL PURPOSE BLOW GUN

- Polyacetal body
- 114mm aluminium nozzle
- 1/4" brass threaded air inlet
- Vented tip to prevent pressure exceeding 30PSI in case of blockage



Part No.	Code	Description
GZ-61080	ABG-30	General Purpose Blow Gun

114MM BLOW GUNS

All of the professional features above, plus:

- 114mm long stainless steel nozzle
- Vented tip to prevent pressure exceeding 30PSI in case of blockage
- Safety model



Part No.	Code	Description
GZ-61002	ABG-3	115mm Blow Gun
GZ-61052	NZL/VEN/ABG/3	Venturi Nozzle To Suit ABG-3
GZ-61053	NZL/RT1/ABG/3	Rubber Tip, 1/2" (12.7mm) To Suit ABG-3
GZ-61054	NZL/RT2/ABG/3	Rubber Tip, 1" (25.4mm) To Suit ABG-3
GZ-61055	NZL/RT3/ABG/3	Rubber Tip, 1-3/8" (35mm) To Suit ABG-3
GZ-64050	PS/ABG/3	Protective Shield, 4" (100mm) To Suit ABG-3
GZ-61051	NZL/SIL/ABG/3	Silencer Nozzle To Suit ABG-3

SILENCED BLOW GUN

All of the professional features above, plus:

- 114mm long stainless steel nozzle & silencer
- Noise level 75ZdB at 100PSI
- Snub nose soft rubber tip
- Safety model



Part No.	Code	Description
GZ-61003	ABG-4	Silenced Blow Gun

BLOW GUN KIT

7 piece kit including:

- GZ-61002 114mm air blow gun
- 4" (100mm) protective shield
- Soft rubber silencer nozzle for use on delicate materials
- Venturi nozzle for turbo charged output
- 12.7mm (1/2") rubber tip
- 25.4mm (1") rubber tip
- 35mm (1-3/8") rubber tip



Part No.	Code	Description
GZ-61070	ABG-3KIT	Blow Gun Kit

PRO SERIES SAFETY AIR BLOW GUNS

- Unlike any other metal body lever air gun, the Groz Pro Series feature a revolutionary Venturi mechanism that uses side ports to combine free ambient air with costly compressed air, creating a much higher volume of usable output.
- Manufactured from die cast aluminium; these are made to last in the harshest environments.
- Ergonomic design of the body & large dip coated operating lever reduces user fatigue & discomfort, even during extended use.
- 1/4" female inlet
- 1/8" female outlet
- Variable air control
- Max pressure : 150PSI (10 BAR)
- Max dB : 85

1/2" RUBBER TIP



Part No.	Code	OAL	Description
GZ-61200	LAG/A/1-4	127mm	1/2" Rubber Tip Pro Series Blow Gun

STANDARD MODEL SAFETY MODEL



Part No.	Code	OAL	Description
GZ-61202	LAG/C/1-4	109mm	Standard Pro Series Blow Gun

HIGH FLOW SAFETY MODEL



Part No.	Code	OAL	Description
GZ-61203	LAG/D/1-4	132mm	High Flow Pro Series Blow Gun

TAMPERPROOF SAFETY MODEL



Part No.	Code	OAL	Description
GZ-61205	LAG/F/1-4	127mm	Tamperproof Pro Series Blow Gun

SILENCER NOZZLE



Part No.	Code	OAL	Description
GZ-61208	LAG/J/1-4	135mm	Silencer Nozzle Pro Series Blow Gun

WIRE TUBE BRUSH



Part No.	Code	Description
GZ-61215	LAG/S/1-4	Wire Tube Brush Pro Series Blow Gun

PRO SERIES SAFETY AIR BLOW GUN KITS

GZ-61260 6 PIECE KIT

Includes:

- Pro series safety air blow gun
- 1/2" rubber tip (GZ-61277)
- Stainless steel needle, 1-3/4" x 0.072" Ø (GZ-61290)
- Stainless steel needle, 2-15/32" x 0.095" Ø (GZ-61291)
- Mini aluminium tip (GZ-61289)
- 3" long nylon tapered tube (GZ-61288)



Part No.	Code
GZ-61260	KIT/LAG/6/ST

GZ-61261 8 PIECE KIT

Includes:

- Pro series safety air blow gun
- 1/2" rubber tip (GZ-61277)
- Standard safety tip (GZ-61279)
- High flow safety (GZ-61280)
- 1-1/4" nylon screen (GZ-61286)
- Mini aluminium tip (GZ-61289)
- Brass adjustable (GZ-61292)
- 3" long nylon tapered tube (GZ-61288)



Part No.	Code
GZ-61261	KIT/LAG/8/ST

GZ-61262 5 PIECE KIT

Includes:

- Pro series safety air blow gun
- 1/2" rubber tip (GZ-61277)
- Standard safety tip (GZ-61279)
- Mini aluminium tip (GZ-61289)
- Stainless steel needle, 2-15/32" x 0.095" Ø (GZ-61291)



Part No.	Code
GZ-61262	KIT/LAG/5/ST

GZ-61266 23 PIECE KIT

Includes:

- 2x Pro series safety air blow guns
- 1/2" rubber tip (GZ-61277)
- Standard (GZ-61278)
- Standard safety (GZ-61279)
- High flow safety (GZ-61280)
- Safety booster (GZ-61281)
- Safety tamperproof (GZ-61282)
- 1" rubber tip (GZ-61283)
- 1-3/8" rubber tip (GZ-61284)
- Rubber silencer (GZ-61285)
- 1-1/4" nylon screen (GZ-61286)
- 4" protective shield nozzle (GZ-61287)
- 3" long nylon tapered tube (GZ-61288)
- Mini aluminium tip (GZ-61289)
- Stainless steel needle, 1-3/4" x 0.072" Ø (GZ-61290)
- Stainless steel needle, 2-15/32" x 0.095" Ø (GZ-61291)
- Brass adjustable (GZ-61292)
- 23" long with rubber tip (GZ-61293)

Part No.	Code
GZ-61266	KIT/LAG/21/ST

GZ-61263 5 PIECE KIT

Includes:

- Pro series safety air blow gun
- 1/2" rubber tip (GZ-61277)
- Standard safety tip (GZ-61279)
- Stainless steel needle, 1-3/4" x 0.072" Ø (GZ-61290)
- Stainless steel needle, 2-15/32" x 0.095" Ø (GZ-61291)



Part No.	Code
GZ-61263	KIT/LAG/5A/ST

GZ-61264 4 PIECE KIT

Includes:

- Pro series safety air blow gun
- 1/2" rubber tip (GZ-61277)
- 1" rubber tip (GZ-61283)
- 1-3/8" rubber tip (GZ-61284)



Part No.	Code
GZ-61264	KIT/LAG/4/ST

GZ-61265 5 PIECE KIT

Includes:

- Pro series safety air blow gun
- 3" aluminium tube (GZ-61296)
- 6" aluminium tube (GZ-61297)
- 9" aluminium tube (GZ-61298)
- 12" aluminium tube (GZ-61299)

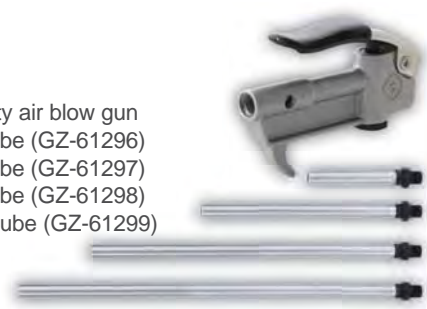











Part No.	Code
GZ-61265	KIT/LAG/5B/ST

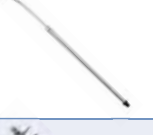

- 14" to 24" telescopic tip (GZ-61294)
- Steel wire brush (GZ-61295)
- 3" aluminium tube (GZ-61296)
- 6" aluminium tube (GZ-61297)

PRO SERIES SAFETY AIR BLOW GUN ACCESSORIES

Part No.	Code	Description	Image
GZ-61277	ZSA/NZL/A/LAG	1/2" (12.7mm) Rubber Tip	
GZ-61278	ZSA/NZL/B/LAG	Standard	
GZ-61279	ZSA/NZL/C/LAG	Standard Safety	
GZ-61280	ZSA/NZL/D/LAG	High Flow Safety	
GZ-61281	ZSA/NZL/E/LAG	Safety Booster	
GZ-61282	ZSA/NZL/F/LAG	Safety Tamperproof	
GZ-61283	ZSA/NZL/G/LAG	1" (25.4mm) Rubber Tip	
GZ-61284	ZSA/NZL/H/LAG	1-3/8" (35mm) Rubber Tip	
GZ-61285	ZSA/NZL/J/LAG	Rubber Silencer	
GZ-61286	ZSA/NZL/K/LAG	1-1/4" (32mm) Nylon Screen	
GZ-61287	ZSA/NZL/PS/LAG	4" (100mm) Protective Shield Nozzle	
GZ-61288	ZSA/NZL/L/LAG	3" (75mm) Long Nylon Tapered Tube	

Part No.	Code	Description	Image
GZ-61289	ZSA/NZL/M/LAG	Mini Aluminium Tip	
GZ-61290	ZSA/NZL/N1/LAG	Stainless Steel Needle, 1-3/4" x 0.072" (44 x 1.8mm)Ø	
GZ-61291	ZSA/NZL/N2/LAG	Stainless Steel Needle, 2-15/32" x 0.095" (63 x 2.4mm) Ø	
GZ-61292	ZSA/NZL/P/LAG	Brass Adjustable	
GZ-61293	ZSA/NZL/Q/LAG	23" (585mm) Long With Rubber Tip	
GZ-61294	ZSA/NZL/R/LAG	14" To 24" (355 To 610mm) Telescopic Tip	
GZ-61295	ZSA/NZL/S/LAG	Steel Wire Brush	
GZ-61296	ZSA/NZL/T1/LAG	3" (75mm) Aluminium Tube	
GZ-61297	ZSA/NZL/T2/LAG	6" (150mm) Aluminium Tube	
GZ-61298	ZSA/NZL/T3/LAG	9" (230mm) Aluminium Tube	
GZ-61299	ZSA/NZL/T4/LAG	12" (305mm) Aluminium Tube	

FILTERS & REGULATORS

AIR REGULATORS

- Non raising "Press to Lock" adjusting knob for locking at any set pressure.
- Diaphragm operated, relieving type mechanism with pressure compensated by balanced poppet. These can be installed in any position & need not be vertically mounted
- Intermediate, standard and heavy duty regulators with in-built venturi for flow compensation
- 220 psi maximum pressure
- 0° - 60° ambient temperature
- Modular mounting and vertical mounting features
- Includes gauge & bracket



Part No.	Code	Description	Port Size	Pressure Gauge Port Size	Flow Rate CFM (LPM)	Height x Width mm
GZ-60020	R13604/GB	Miniature	1/8"	1/8"	17 (480)	81 x 40
GZ-60021	R13614/GB	Miniature	1/4"	1/8"	21 (600)	81 x 40
GZ-60022	R14614/GB	Intermediate	1/4"	1/8"	56 (1600)	135 x 55
GZ-60023	R14624/GB	Intermediate	3/8"	1/8"	88 (2500)	135 x 55
GZ-60024	R15634/GB	Standard	1/2"	1/8"	140 (4000)	165 x 70
GZ-60025	R17644/GB	Heavy Duty	3/4"	1/4"	175 (5000)	177 x 90
GZ-60026	R17654/GB	Heavy Duty	1"	1/4"	210 (6000)	177 x 90

AIR FILTERS

- Die cast aluminum filter head, polycarbonate bowl with a steel bowl guard & high performance sintered 40 micron Bronze filtering element
- Designed with a Separator & Shield for efficient moisture separation
- 145 psi maximum pressure
- 0° - 60° ambient temperature
- Modular mounting and vertical mounting features



Part No.	Code	Description	Port Size	Flow Rate CFM (LPM)	Bowl Size	Height x Width mm
GZ-60100	F13603-S	Miniature	1/8"	11 (310)	9ml	113 x 40
GZ-60101	F13613-S	Miniature	1/4"	28 (800)	9ml	113 x 40
GZ-60102	F14613-S	Intermediate	1/4"	49 (1400)	32ml	140 x 55
GZ-60103	F14623-S	Intermediate	3/8"	80 (2250)	32ml	140 x 55
GZ-60104	F15633-S	Standard	1/2"	125 (3500)	44ml	172 x 70
GZ-60105	F17643-S	Heavy Duty	3/4"	175 (5000)	165ml	260 x 90
GZ-60106	F17653-S	Heavy Duty	1"	230 (6500)	165ml	260 x 90

COALESCING AIR FILTERS

- Used to remove sub micron oil, water droplets and solid contaminants
- Choice of 0.01 micron or 0.10 micron filtering element
- Die cast aluminum filter head, polycarbonate bowl with a steel bowl guard & high performance Borosilicate filtering element
- Designed with a separator for efficient moisture separation
- Press type manual drain with night time drain feature which automatically drains off the bowl once the compressed air supply to the filter is switched off

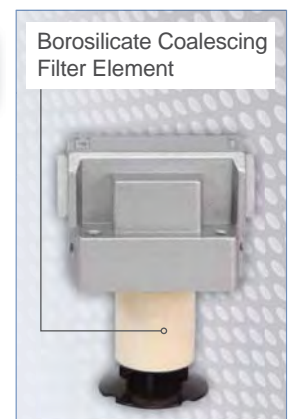

Part No.	Code	Description	Port Size
GZ-60804	FS15633-S	0.10 Micron, Standard	1/2"
GZ-60824	FS15632-S	0.01 Micron, Standard	1/2"

AIR FILTER REGULATORS

Die cast aluminum body, polycarbonate bowl with a steel bowl guard & a high performance sintered bronze filtering element

- Designed with a separator & shield for efficient moisture separation. It is combined with a Regulator which maintains a steady outlet pressure, unaffected by variations & fluctuations in the inlet pressure
- Non raising "Press To Lock" adjusting knob for locking at any set pressure
- Pressure adjustment range of 7 - 145 PSI (0.5 - 10 BAR)
- 40 micron filtering element press type manual drain with night time drain feature which automatically drains off the bowl once the compressed air supply to the filter is switched off
- Miniature air regulators have a threaded type steel bowl guard
- Intermediate, standard & heavy duty have a bayonet type steel bowl guard, regulator with in-built venturi for flow compensation
- 0° - 60° ambient temperature
- Modular mounting and vertical mounting features
- Includes gauge & bracket

Part No.	Code	Description	Port Size	Pressure Gauge Port Size	Flow Rate CFM (LPM)	Bowl Size	Height x Width
GZ-60321	FRC136034-S/GB	Miniature	1/8"	1/8"	14 (400)	9ml	170 x 40mm
GZ-60322	FRC136134-S/GB	Miniature	1/4"	1/8"	20 (550)	9ml	170 x 40mm
GZ-60323	FRC146134-S/GB	Intermediate	1/4"	1/8"	63 (1800)	32ml	220 x 55mm
GZ-60324	FRC146234-S/GB	Intermediate	3/8"	1/8"	77 (2200)	32ml	220 x 55mm
GZ-60325	FRC156334-S/GB	Standard	1/2"	1/8"	106 (3000)	44ml	280 x 70mm
GZ-60326	FRC176434-S/GB	Heavy Duty	3/4"	1/4"	149 (4250)	165ml	370 x 90mm
GZ-60327	FRC176534-S/GB	Heavy Duty	1"	1/4"	190 (5500)	165ml	370 x 90mm

AIR FILTER REGULATOR & LUBRICATORS

With all of the features of the standard Groz air filter regulator, and air lubricator

- Come complete with a wall mounting bracket

Part No.	Code	Description	Port Size	Pressure Gauge Port Size	Flow Rate CFM (LPM)	Bowl Size (Filter)	Bowl Size (Lubricator)
GZ-60405	FRCLM136134-S/G	Miniature	1/4"	1/8"	18 (500)	9ml	20ml
GZ-60421	FRCLM146134-S/G	Intermediate	1/4"	1/8"	53 (1500)	32ml	57ml
GZ-60406	FRCLM146234-S/G	Intermediate	3/8"	1/8"	63 (1800)	32ml	57ml
GZ-60407	FRCLM156334-S/G	Standard	1/2"	1/8"	99 (2800)	44ml	152ml
GZ-60408	FRCLM176434-S/G	Heavy Duty	3/4"	1/4"	123 (3500)	165ml	200ml
GZ-60409	FRCLM176534-S/G	Heavy Duty	1"	1/4"	124 (4000)	165ml	200ml

AIR LUBRICATORS

145 psi maximum pressure

0° - 60° ambient temperature

- Maintain a constant oil-to-air density over a wide range of flow.
- The Groz L1 series lubricators are fog / micro-mist type, up to 50' pipe runs
- Die cast aluminum head, polycarbonate bowl with a steel bowl guard. The head is fitted with oil drop indicator, oil drop controller & oil filling plug
- Modular mounting and vertical mounting features

Part No.	Code	Description	Port Size	Flow Rate CFM (LPM)	Bowl Size	Height x Width mm
GZ-60200	L1360	Miniature	1/8"	16 (450)	20ml	135 x 40
GZ-60201	L1361	Miniature	1/4"	48 (1350)	20ml	135 x 40
GZ-60206	L1461	Intermediate	1/4"	58 (1650)	57ml	157 x 55
GZ-60202	L1462	Intermediate	3/8"	106 (3000)	57ml	157 x 55
GZ-60203	L1563	Standard	1/2"	200 (5650)	152ml	190 x 70
GZ-60204	L1764	Heavy Duty	3/4"	255 (7200)	200ml	273 x 90
GZ-60205	L1765	Heavy Duty	1"	318 (9000)	200ml	273 x 90



MOUNTING BRACKETS FOR LUBRICATOR OR FILTER



Part No.	Code	Description
GZ-60610	A2C31	Suit Miniature Units
GZ-60611	A2C32	Suit Intermediate Units
GZ-60612	A2C33	Suit Standard Units
GZ-60613	A2C34	Suit Heavy Duty Units

EXTERNAL AUTO DRAIN VALVES

The auto drain valve drains the condensate water automatically. In addition to automatic draining, there is also provision in the valve for manual drain off.

Unlike an electrical auto drain valve, these float type auto drain valves operates only when the condensate is collected & drains only the condensate.



Part No.	Code	Description
GZ-60621	A2D02	Suit Intermediate Units
GZ-60622	A2D03	Suit Standard Units
GZ-60623	A2D04	Suit Heavy Duty Units

SAFETY LOCKOUT VALVES

- The Safety Lockout valve is a hand operated, knob-type, 2 positions, 3 way valve that can be turned to Supply or Exhaust
- Provision for external pad lock for preventing accidental actuation during lock out
- Modular construction allows the valve to be connected with any of the Groz air control units using a spacer
- Lockout valves are threaded both at inlet & outlet
- 145 PSI Maximum pressure



Part No.	Code	Port Size	Flow Supply Rate CFM (LPM)	Flow Exhaust Rate CFM (LPM)	Height x Width
GZ-60721	LKV/1361	1/4"	35 (1000)	16 (450)	73x45mm
GZ-60723	LKV/1462	3/8"	78 (2200)	39 (1100)	85x55mm
GZ-60724	LKV/1563	1/2"	115 (3250)	56 (1600)	94x70mm

PRESSURE GAUGES

- BAR & PSI with a maximum reading of 200PSI/14 BAR
- Graduated in intervals of 5 PSI/0.20 BAR and is accurate to within 5%



Part No.	Code	Description
GZ-60630	A2G02	1/8" BSP
GZ-60631	A2G08	1/4" BSP

DIGITAL PRESSURE GAUGES

Maximum pressure : 300 PSI (20 BAR)

Measuring range : 0 to 150PSI, 0 to 10 BAR, 0 to 1.0 MpA, 0 to 10 Kg/Cm²

Minimum reading : 0.1 PSI, 0.01 BAR, 0.001 MpA, 0.01 Kg/Cm², Operating Temperature : -10°C to + 60°C

Water proof rating : IP65

Battery type : CR2032

- Compared to a mechanical gauge, the digital gauge offers higher accuracy, higher pressure, better resistance to vibration & easier reading (back lit)
- Square body 30mm² with cast aluminium centre back male threads



Part No.	Code	Description
GZ-60632	DPG/L/1-8/B	1/8" For Use With Miniature, Intermediate & Standard Models
GZ-60633	DPG/L/1-4/B	1/4" For Use With Heavy Duty Models

AIR SPACERS

Used to connect 2 components in modular assemblies.



GZ-60650



GZ-60654

Part No.	Code	Description
GZ-60650	A2S01	Suit Miniature Units
GZ-60651	A2S02	Suit Intermediate Units
GZ-60652	A2S03	Suit Standard Units
GZ-60653	A2S04	Suit Heavy Duty Units
GZ-60654	A2T01	Suit Miniature Units, Comes With Air Outlet Port
GZ-60655	A2T02	Suit Intermediate Units, Comes With Air Outlet Port
GZ-60656	A2T03	Suit Standard Units, Comes With Air Outlet Port

AIR LINE COUPLERS

STEEL AIR LINE COUPLERS

Approximate air flow : 1500 L/M (53 CFM) at 85 PSI

- Sockets packed 5 per box
- Plugs packed 10 per box



Male Thread Socket		Female Thread Socket		Hose Tail Socket		Male Thread Plug		Female Thread Plug		Hose Tail Plug	
Part No.	Thread Size	Part No.	Thread Size	Part No.	Hose Size	Part No.	Thread Size	Part No.	Thread Size	Part No.	Hose Size
NC20SM	1/4"	NC20SF	1/4"	NC20SH	5/16" (8mm)	NC20PM	1/4"	NC20PF	1/4"	NC20PH	5/16" (8mm)
NC30SM	3/8"	NC30SF	3/8"	NC30SH	3/8" (10mm)	NC30PM	3/8"	NC30PF	3/8"	NC30PH	3/8" (10mm)
NC40SM	1/2"	NC40SF	1/2"	NC40SH	1/2" (12mm)	NC40PM	1/2"	NC40PF	1/2"	NC40PH	1/2" (12mm)

STEEL AIR LINE COUPLERS RETAIL PACKS

Approximate air flow : 1500 L/M (53 CFM) at 85 PSI

- Sockets packed 1 per box
- Plugs packed 2 per box



Male Thread Socket		Female Thread Socket		Hose Tail Socket		Male Thread Plug		Female Thread Plug		Hose Tail Plug	
Part No.	Thread Size	Part No.	Thread Size	Part No.	Hose Size	Part No.	Thread Size	Part No.	Thread Size	Part No.	Hose Size
NC20SM-P	1/4"	NC20SF-P	1/4"	NC20SH-P	5/16" (8mm)	NC20PM-P	1/4"	NC20PF-P	1/4"	NC20PH-P	5/16" (8mm)
NC30SM-P	3/8"	NC30SF-P	3/8"	NC30SH-P	3/8" (10mm)	NC30PM-P	3/8"	NC30PF-P	3/8"	NC30PH-P	3/8" (10mm)
NC40SM-P	1/2"	NC40SF-P	1/2"	NC40SH-P	1/2" (12mm)	NC40PM-P	1/2"	NC40PF-P	1/2"	NC40PH-P	1/2" (12mm)

STAINLESS STEEL AIR LINE COUPLERS

Approximate air flow : 1500 L/M (53 CFM) at 85 PSI

- Packed 5 per box

Male Thread Socket		Female Thread Socket		Hose Tail Socket		Male Thread Plug		Female Thread Plug		Hose Tail Plug	
Part No.	Thread Size	Part No.	Thread Size	Part No.	Hose Size	Part No.	Thread Size	Part No.	Thread Size	Part No.	Hose Size
SS20SM	1/4"	SS20SF	1/4"	SS20SH	5/16" (8mm)	SS20PM	1/4"	SS20PF	1/4"	SS20PH	5/16" (8mm)
SS30SM	3/8"	SS30SF	3/8"	SS30SH	3/8" (10mm)	SS30PM	3/8"	SS30PF	3/8"	SS30PH	3/8" (10mm)
SS40SM	1/2"	SS40SF	1/2"	SS40SH	1/2" (12mm)	SS40PM	1/2"	SS40PF	1/2"	SS40PH	1/2" (12mm)

HI-FLOW AIR LINE COUPLERS

Approximate air flow : 12000 L/M (423 CFM) at 140 PSI)



Male Thread Socket		Female Thread Socket		Hose Tail Socket		Male Thread Plug		Female Thread Plug		Hose Tail Plug	
Part No.	Thread Size	Part No.	Thread Size	Part No.	Hose Size	Part No.	Thread Size	Part No.	Thread Size	Part No.	Hose Size
NC400SM	1/2"	NC400SF	1/2"	NC400SH	1/2"(12mm)	NC400PM	1/2"	NC400PF	1/2"	NC400PH	1/2"(12mm)
NC600SM	3/4"	NC600SF	3/4"	NC600SH	3/4"(19mm)	NC600PM	3/4"	NC600PF	3/4"	NC600PH	3/4"(19mm)
NC800SM	1"	NC800SF	1"	NC800SH	1"(25mm)	NC800PM	1"	NC800PF	1"	NC800PH	1"(25mm)

SINGLE ACTION SOCKETS

Approximate air flow : 1500 L/M (53 CFM) at 85 PSI

- Packed 5 per box



Male Thread Socket		Female Thread Socket		Hose Tail Socket	
Part No.	Thread Size	Part No.	Thread Size	Part No.	Hose Size
T20SMT	1/4"	T20SFT	1/4"	T20SHT	5/16" (8mm)
T30SMT	3/8"	T30SFT	3/8"	T30SHT	3/8" (10mm)
T40SMT	1/2"	T40SFT	1/2"	T40SHT	1/2" (12mm)

SWIVEL AIR LINE COUPLER



Part No.	Description
NC-J702	Hose Tail, 1/4" Thread Size

AIR MANIFOLDS

AIR MANIFOLDS - SINGLE ACTION COUPLERS

Input : 1/4"

Output : 1/4"

- Include NC20PM plug



Part No.	Description
SML-2	2 Way Air Manifold With Single Action Couplers
SMT-3	3 Way Air Manifold With Single Action Couplers
SMM-4	4 Way Air Manifold With Single Action Couplers
SMX-5	5 Way Air Manifold With Single Action Couplers

AIR MANIFOLDS - STANDARD COUPLERS

Input : 1/4"

Output : 1/4"

- Include NC20PM plug



Part No.	Description
SML-2S	2 Way Air Manifold With Standard Couplers
SMT-3S	3 Way Air Manifold With Standard Couplers
SMM-4S	4 Way Air Manifold With Standard Couplers
SMX-5S	5 Way Air Manifold With Standard Couplers



AIR MANIFOLDS

AIR MANIFOLD BODIES

Input : 1/4"
Output : 1/4"



Part No.	Description
SML-2B	2 Way Air Manifold Body
SMT-3B	3 Way Air Manifold Body
SMM-4B	4 Way Air Manifold Body
SMX-5B	5 Way Air Manifold Body

IN LINE MOUNTABLE AIR MANIFOLD BODIES

Input : 1/2"
Output : 1/4"



SM3BP

Part No.	Description
SM2BP	2 Way Air Manifold Body
SM3BP	3 Way Air Manifold Body
SM4BP	4 Way Air Manifold Body
SM5BP	5 Way Air Manifold Body

IN LINE MOUNTABLE AIR MANIFOLDS

Input : 1/2"
Output : 1/4"



Part No.	Description
SM2BA	2 Way In Line Air Mountable Manifold
SM3BA	3 Way In Line Air Mountable Manifold
SM4BA	4 Way In Line Air Mountable Manifold
SM5BA	5 Way In Line Air Mountable Manifold

Y INLINE AIR MANIFOLDS

Input : 1/4"
Output : 1/4"

- Single action couplers
- Include NC20PM plug



Part No.	Description
SMV-2	2 Way 'Y' Inline Air Manifold Incl. 20PM Fitting
SMY-3	3 Way 'Y' Inline Air Manifold Incl. 20PM Fitting

SWIVEL AIR MANIFOLDS

Input : 1/4"
Output : 1/4"

- Single action couplers
- Include NC20PM plug



Part No.	Description
SRL-S13	2 Way With 1/4" Female Air Inlet
SRLL-S13	2 Way With 1/4" Plug Inlet
SRT-S13	3 Way With 1/4" Female Air Inlet



AIR HOSES & ACCESSORIES

MULTIFLEX AIR HOSE

General Purpose Air Hose - 230PSI



Part No.	Diameter	Length	Description
NH10X20	10mm	20m	-
NH10X20C/W	10mm	20m	Complete With Couplers
NH10X30	10mm	30m	-
NH10X30C/W	10mm	30m	Complete With Couplers
NH10X100	10mm	100m	-

BARFELL ULTRAFLEX AIR HOSE

Premium Grade Air Hose - 290PSI



Part No.	Diameter	Length	Description
NYL06X100	6mm	100m	-
NYL08X100	8mm	100m	-
NYL10X10	10mm	10m	-
NYL10X10C/W	10mm	10m	Complete With Couplers
NYL10X15	10mm	15m	-
NYL10X15C/W	10mm	15m	Complete With Couplers
NYL10X20	10mm	20m	-
NYL10X20C/W	10mm	20m	Complete With Couplers
NYL10X30	10mm	30m	-
NYL10X30C/W	10mm	30m	Complete With Couplers
NYL10X100	10mm	100m	-
NYL10X300	10mm	300m	-
NYL12x20	12mm	20m	-
NYL12x20C/W	12mm	20m	Complete With Couplers
NYL12x250	12mm	250m	-

M7-SA3315 PLASTIC AIR HOSE REEL

Hose length : 15m
I.D. : 10mm
O.D. : 15mm
Male PT Fitting : 3/8"
Net weight : 6.0kg

- Wall mounted shock proof plastic case



M7-SA2015 METAL BODY AIR HOSE REEL

Hose length : 15m
I.D. : 8mm
O.D. : 12mm
Male PT Fitting : 1/4"
Net weight : 6.2kg

- Heavy-duty hoses
- Commercial grade auto-rewind air hose reels
- Durable spring powered recoil
- Heavy duty wall mounted steel case



M7-SA4320 METAL AIR HOSE REEL

Hose length : 20m
I.D. : 10mm
O.D. : 18mm
Male PT Fitting : 3/8"
Net weight : 24.0kg

- Wall mounted open steel case



Part No.	Inside Diameter	Outside Diameter	Hose Length	Working Pressure	Break Pressure	Male PT Fitting	Weight
	mm	mm	m	PSI	PSI	inch	kg
M7-SA3315	10	1	15	90	300	3/8"	6.0
M7-SA2015	8	12	15	101.5	284.4	1/4"	6.2
M7-SA4320	10	18	20	90	300	3/8"	24.0

TM300-120 20M LENGTH
TM300-130 30M LENGTH
PVC AIR HOSE

- High quality durable PVC air hose
- Grease, oil and abrasion resistant
- 300 PSI maximum working pressure
- Non-marking
- 3/8" (10mm) internal diameter



TM300-210 10M LENGTH
TM300-220 20M LENGTH
TM300-230 30M LENGTH
FITTED PVC AIR HOSE

- High quality durable PVC Air Hose
- Nitto style quick release fittings
- Bend restrictor extends hose line
- Grease, oil and abrasion resistant
- 300 PSI maximum working pressure
- Non-marking
- 3/8" (10mm) internal diameter



TM300-315 15M LENGTH
TM300-330 30M LENGTH
HIGH FLEX AIR HOSE

- Hybrid polymer High-Flex hose
- Anti-kink technology, the hose will not kink when under pressure
- Nitto style quick release fittings
- Superior all weather flexibility -5°C to 65°C
- 300PSI maximum working pressure
- Hi-visibility for safety
- 3/8" (10mm) internal diameter



Part No.	Hose Length	Max Working Pressure	Material	Fittings
	m	PSI		mm
TM300-120	20	300	PVC	None
TM300-130	30	300	PVC	None
TM300-210	10	300	PVC	Nitto style quick release
TM300-220	20	300	PVC	Nitto style quick release
TM300-230	30	300	PVC	Nitto style quick release
TM300-315	15	300	Hybrid polymer high-flex	Nitto style quick release
TM300-330	30	300	Hybrid polymer high-flex	8 Nitto style quick release

TM300-015 15M RETRACTABLE AIR HOSE REEL

- Reinforced PVC Hose
- Auto lock to any required length
- Auto track guided hose layering system
- Adjustable hose stopper
- Detachable 180° swivel mounting bracket



TM300-020 20M RETRACTABLE AIR HOSE REEL

- Hybrid Polymer High Flex Hose
- Superior all weather flexibility, no KINK, even in extreme temperatures -5°C to 65°C
- High visibility fluoro orange hose
- Auto lock to any required length
- Auto track guided hose layering system
- Adjustable hose stopper
- Detachable 180° swivel mounting bracket



TM300-030 30M MANUAL AIR HOSE REEL

- Braided PVC Hose
- Durable steel powder coated frame
- Wall mount bracket included
- Bend restrictor extends hose line
- 8mm I.D. hose



Part No.	Max Working Pressure	Leader Hose Length	Hose I.D.
	PSI	m	mm
TM300-015	250	1.5	10
TM300-020	250	2	10
TM300-030	300	?	8

Magnetic Base Drilling Machines

Cutting Tools

Clamps

Engineer's Tools

Sharpening Machines

Metal Cutting Saws

Drilling Machines

Bevelling Machines & Welding Carriages

Punches & Shears

Grinding Machines

Fans & Ventilators

Workshop Storage

M7 Airtools

NPK Airtools

Pneumatic Products

STRAIGHT POLYURETHANE AIR HOSE



Part No.	Internal Diameter	Outside Diameter	Colour	Length
HUS2504BS	2.5mm	4mm	Blue	200m
HUS2504BK	2.5mm	4mm	Black	200m
HUS4006BS	4mm	6mm	Blue	200m
HUS4006BK	4mm	6mm	Black	200m
HUS5508BS	5.5mm	8mm	Blue	100m
HUS5508BK	5.5mm	8mm	Black	100m
HUS6510BS	6.5mm	10mm	Blue	100m
HUS6510BK	6.5mm	10mm	Black	100m
HUS8012BS	8mm	12mm	Blue	100m
HUS8012BK	8mm	12mm	Black	100m

BRAIDED POLYURETHANE AIR HOSE

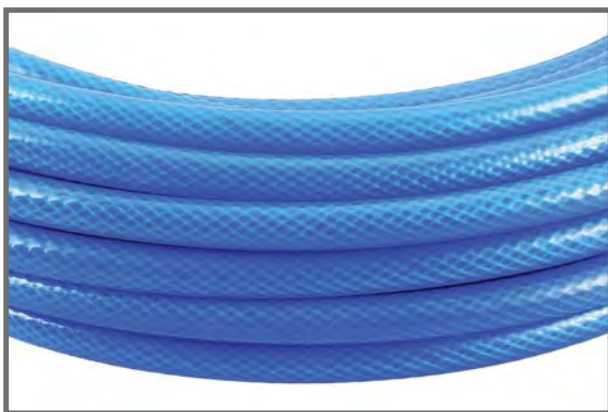

Part No.	Internal Diameter	Outside Diameter	Colour	Length
HUB6510	6.5mm	10mm	Yellow	100m
HUB8012	8mm	12mm	Blue	100m

PREMIUM POLYURETHANE RECOIL AIR HOSE

With single action fittings



Part No.	Internal Diameter	Outside Diameter	Colour	Working Length
HUZ5508-05BS	5.5mm	8mm	Blue	5m
HUZ5508-10BS	5.5mm	8mm	Blue	10m
HUZ6510-05BS	6.5mm	10mm	Blue	5m
HUZ6510-10BS	6.5mm	10mm	Blue	10m
HUZ8012-05BS	8mm	12mm	Blue	5m
HUZ8012-10BS	8mm	12mm	Blue	10m

PREMIUM POLYURETHANE RECOIL AIR HOSE

Without fittings



Part No.	Internal Diameter	Outside Diameter	Colour	Working Length
HUR5508-05BS	5.5mm	8mm	Blue	5m
HUR5508-10BS	5.5mm	8mm	Blue	10m
HUR6510-05BS	6.5mm	10mm	Blue	5m
HUR6510-10BS	6.5mm	10mm	Blue	10m
HUR8012-05BS	8mm	12mm	Blue	5m
HUR8012-10BS	8mm	12mm	Blue	10m

ECONOMY POLYURETHANE RECOIL AIR HOSE

With single action fittings



Part No.	Internal Diameter	Outside Diameter	Colour	Working Length
HUZ8012-05OR	8mm	12mm	Orange	4.5m
HUZ8012-10OR	8mm	12mm	Orange	9m

PUSH FIT FITTINGS**MALE STRAIGHT NIPPLE**

For use with THB polyurethane air hose



Part No.	Thread Size	Tube Outside Diameter Size
JPC04M5	M5	4mm
JPC06M5	M5	6mm
JPC0401	1/8"	4mm
JPC0402	1/4"	4mm
JPC0601	1/8"	6mm
JPC0602	1/4"	6mm
JPC0603	3/8"	6mm
JPC0604	1/2"	6mm
JPC0801	1/8"	8mm
JPC0802	1/4"	8mm
JPC0803	3/8"	8mm
JPC0804	1/2"	8mm
JPC1001	1/8"	10mm
JPC1002	1/4"	10mm
JPC1003	3/8"	10mm
JPC1004	1/2"	10mm
JPC1202	1/4"	12mm
JPC1203	3/8"	12mm
JPC1204	1/2"	12mm

MALE TEEFor use with THB
polyurethane air hose

Part No.	Thread Size	Tube Outside Diameter Size
JPB0401	1/8"	4mm
JPB0402	1/4"	4mm
JPB0601	1/8"	6mm
JPB0602	1/4"	6mm
JPB0603	3/8"	6mm
JPB0801	1/8"	8mm
JPB0802	1/4"	8mm
JPB0803	3/8"	8mm
JPB1001	1/8"	10mm
JPB1002	1/4"	10mm
JPB1003	3/8"	10mm
JPB1004	1/2"	10mm
JPB1202	1/4"	12mm
JPB1203	3/8"	12mm
JPB1204	1/2"	12mm

MALE ELBOWFor use with THB
polyurethane air hose

Part No.	Thread Size	Tube Outside Diameter Size
JPL04M5	M5	4mm
JPL06M5	M5	6mm
JPL0401	1/8"	4mm
JPL0402	1/4"	4mm
JPL0601	1/8"	6mm
JPL0602	1/4"	6mm
JPL0603	3/8"	6mm
JPL0604	1/2"	6mm
JPL0801	1/8"	8mm
JPL0802	1/4"	8mm
JPL0803	3/8"	8mm
JPL0804	1/2"	8mm
JPL1001	1/8"	10mm
JPL1002	1/4"	10mm
JPL1003	3/8"	10mm
JPL1004	1/2"	10mm
JPL1202	1/4"	12mm
JPL1203	3/8"	12mm
JPL1204	1/2"	12mm

MALE BRANCH TEEFor use with THB
polyurethane air hose

Part No.	Thread Size	Tube Outside Diameter Size
JPD0401	1/8"	4mm
JPD0402	1/4"	4mm
JPD0601	1/8"	6mm
JPD0602	1/4"	6mm
JPD0603	3/8"	6mm
JPD0801	1/8"	8mm
JPD0802	1/4"	8mm
JPD0803	3/8"	8mm
JPD1001	1/8"	10mm
JPD1002	1/4"	10mm
JPD1003	3/8"	10mm
JPD1004	1/2"	10mm
JPD1202	1/4"	12mm
JPD1203	3/8"	12mm
JPD1204	1/2"	12mm

STRAIGHT UNION

For use with THB polyurethane air hose



Part No.	Tube Outside Diameter Size
JPU0404	4mm
JPU0606	6mm
JPU0808	8mm
JPU1010	10mm
JPU1212	12mm

MALE BRANCH "Y"

For use with THB polyurethane air hose



Part No.	Thread Size	Tube Outside Diameter Size
JPX0401	1/8"	4mm
JPX0402	1/4"	4mm
JPX0601	1/8"	6mm
JPX0602	1/4"	6mm
JPX0603	3/8"	6mm
JPX0801	1/8"	8mm
JPX0802	1/4"	8mm
JPX0803	3/8"	8mm
JPX1002	1/4"	10mm
JPX1003	3/8"	10mm
JPX1004	1/2"	10mm
JPX1202	1/4"	12mm
JPX1203	3/8"	12mm
JPX1204	1/2"	12mm

INLINE "Y" UNION

For use with THB polyurethane air hose



Part No.	Tube Outside Diameter Size
JPY04	4mm
JPY06	6mm
JPY08	8mm
JPY10	10mm
JPY12	12mm

SPEED CONTROLLER ELBOW

For use with THB polyurethane air hose



Part No.	Thread Size	Tube Outside Diameter Size
JSC0401	1/8"	4mm
JSC0402	1/4"	4mm
JSC0601	1/8"	6mm
JSC0602	1/4"	6mm
JSC0603	3/8"	6mm
JSC0801	1/8"	8mm
JSC0802	1/4"	8mm
JSC0803	3/8"	8mm
JSC0804	1/2"	8mm
JSC1002	1/4"	10mm
JSC1003	3/8"	10mm
JSC1004	1/2"	10mm
JSC1202	1/4"	12mm
JSC1203	3/8"	12mm

UNIVERSAL BANJO ELBOW

For use with THB polyurethane air hose



Part No.	Thread Size	Tube Outside Diameter Size
JPH0401	1/8"	4mm
JPH0401	1/4"	4mm
JPH0601	1/8"	6mm
JPH0602	1/4"	6mm
JPH0603	3/8"	6mm
JPH0801	1/8"	8mm
JPH0802	1/4"	8mm
JPH0803	3/8"	8mm
JPH0804	1/2"	8mm
JPH1002	1/4"	10mm
JPH1003	3/8"	10mm
JPH1004	1/2"	10mm
JPH1202	1/4"	12mm
JPH1203	3/8"	12mm

UNION ELBOW

For use with THB polyurethane air hose



Part No.	Tube Outside Diameter Size
JPV04	4mm
JPV06	6mm
JPV08	8mm
JPV10	10mm
JPV12	12mm

UNION TEE

For use with THB polyurethane air hose



Part No.	Tube Outside Diameter Size
JPE04	4mm
JPE06	6mm
JPE08	8mm
JPE10	10mm
JPE12	12mm

INLINE SPEED CONTROLLER

For use with THB polyurethane air hose



Part No.	Tube Outside Diameter Size
JVA04	4mm
JVA06	6mm
JVA08	8mm
JVA10	10mm

BULKHEAD UNION

For use with THB polyurethane air hose



Part No.	Thread Size	Tube Outside Diameter Size
JPM04	M12	4mm
JPM06	M14	6mm
JPM08	M16	8mm
JPM10	M20	10mm
JPM12	M22	12mm

TRIPLE BRANCH UNION

For use with THB polyurethane air hose



Part No.	Tube Outside Diameter Size
JPF04	4mm
JPF06	6mm
JPF08	8mm

FEMALE STRAIGHT NIPPLE

For use with THB polyurethane air hose



Part No.	Thread Size	Tube Outside Diameter Size
JPCF0401	1/8"	4mm
JPCF0601	1/8"	6mm
JPCF0602	1/4"	6mm
JPCF0603	3/8"	6mm
JPCF0801	1/8"	8mm
JPCF0802	1/4"	8mm
JPCF0803	3/8"	8mm
JPCF1002	1/4"	10mm
JPCF1003	3/8"	10mm
JPCF1004	1/2"	10mm
JPCF1203	3/8"	12mm
JPCF1204	1/2"	12mm



WARRANTY TERMS

In addition to any warranties or conditions implied by applicable Statute or Regulations, Industrial Tool & Machinery Sales warrants all of its products against defective workmanship and faulty materials for a period of twelve (12) months from the date of purchase, unless otherwise stated. At our option we will repair or replace, free of charge, any item on the condition that :

- The return has been authorised by ITM, and a return authority number (RA) has been issued prior to goods being despatched.
- The complete machine or tool is returned, freight prepaid to ITM or one of it's authorised service agents as directed by ITM, and is found to have a material or constructional defect.
- The machine or tool has not been subject to misuse, neglect or damage by accident.
- The fault is not a result of normal "wear and tear".
- Written permission has been received from ITM prior to commencement of repair.
- Repairs, tampering or modification carried out by unauthorised personnel will void all warranty.
- Consumable items such as cutting tools, pilot pins, saw blades, grinding wheels etc. are NOT covered by warranty.

Our goods come with guarantees which cannot be excluded under the Australian Consumer Law. You are entitled to replacement or refund for a major failure and to compensation for other reasonably foreseeable loss or damage. You are also entitled to have the goods repaired or replaced if the goods fail to be of acceptable quality and the failure does not amount to a major failure.



INDUSTRIAL TOOL & MACHINERY SALES

18 BUSINESS ST, YATALA QLD 4207 AUSTRALIA

PH: 07 3287 1114 FX 07 3287 1115

sales@industrialtool.com.au

www.industrialtool.com.au

NATIONAL SALES & DISTRIBUTION LOCATIONS



WWW.INDUSTRIALTOOL.COM.AU