



Z142037

Model 142 Hand Cutting Torches

A traditional one piece cutting torch that has become an industry standard. Be aware of low quality copies that don't comply to ISO standards and ask for Harris original.

Features include- Wt. 1.9kg

- ▶ Top mounted stainless steel cutting lever with hold-down button
- ▶ Solid brass head/body/handle
- ▶ Built-in safety plug in head
- ▶ Ease on for heavy cuts/piercing
- ▶ Universal pressure mixing, fuel gas 1.5kPa
- ▶ Well balanced
- ▶ Accepts flat seating tips, reducing head popping
- ▶ Complete with flash-guards

Z142037 1 pce Hand Cutt Torch **Acet**
Cuts up to 200mm
Ideal - Engineering shops, Mines, Maintenance shops
Includes Flashguards

142033 1 pce Hand Cutt Torch
Propane, LPG, Natural Gas
Cuts up to 200mm
Ideal - Engineering shops, Mines, Maintenance shops
Includes Flashguards

Z142038 Our popular 142 Torch with the head manufactured to suit **tapered seating tips**, suitable for any fuel gas
Note: Not universal mixing

- NOTE:**
- 1) All Propane Torches 624FL & 142F also operate on L.P.G. and Natural Gas.
 - 2) With Propane Torches, Heating Tips up to Size 3 (H623P) can screw onto Torch, meaning you can cut, gouge and heat just by changing Tip.
 - 3) All Torches are fitted with Flashguards to enhance safety and add value.



Z142038



062Z018

Model 624 Hand Cutting Torches

Features include- Wt. 1.5kg

- ▶ Finger control stainless steel cutting lever
- ▶ Solid brass head/body/handle
- ▶ Well balanced for easy piercing/heavy cutting
- ▶ Universal pressure mixing, fuel gas 1.5kPa
- ▶ Accepts flat seating tips reducing head popping.
- ▶ Complete with flashguards
- ▶ Ease on cutting oxygen makes piercing/starts easier

062Z019 1 pce Hand Cutt Torch Acet
Cuts up to 300mm
Ideal - Engineering shops
Includes Flashguards

062Z018 1 pce Hand Cutt Torch Propane,
LPG, Natural Gas
Cuts up to 300mm
Ideal - Engineering shops,
Scrap cutting
Includes Flashguards

062Z037 1 pce Hand Cutt Torch Propane
Cuts up to 300mm - **90° Head**
1000mm length
Ideal - Cutting in hard to
reach places, Scrap cutting
Includes Flashguards **Wt. 1.9kg**

062Z032 1 pce Hand Cutt Torch Propane
Cuts up to 300mm - **180° Head**
1000mm length
Ideal - Where there is a need
for the tip to be straight out of the torch.
Includes Flashguards **Wt. 1.9kg**

This torch is designed to aid an operator when cutting “out of position”. The under-hung lever allows an operator to easily hold the torch and operate cutting process.

Machine Cutting Torches

Oxy/Propane/LPG/Natural Gas

The **Harris** range of machine cutting torches offer the ultimate in gas mixing, performance, ease of adjustment and safety desired by the profile industry. Various diameters, lengths etc. available to allow low cost updating/retrofitting of machines. Further advise or training contact **Harris**.

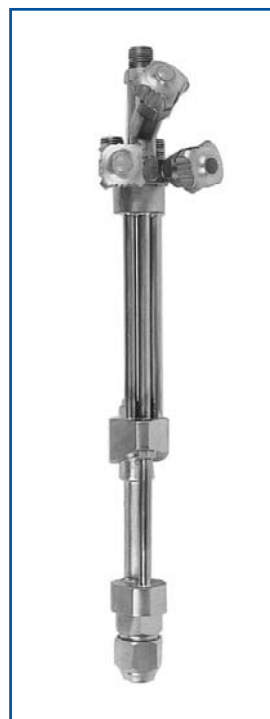

- Z133073** 30mm dia. Barrel x 65mm lgth.
No Valves Wt. 0.9kg
- Z133072** 30mm dia. Barrel x 65mm lgth.
With Valves Wt. 0.9kg
- Z198050** 30mm dia. Barrel x 250mm lgth.
With Valves Wt. 1.7kg
- Z198054** 30mm dia. Barrel x 460mm lgth.
With Valves Wt. 2.0kg
- Z198028** 32mm x 32mm Square Barrel
x 243mm lgth. **With Valves Wt. 1.3kg**
- Z198039** 32mm dia. Barrel x 110 lgth.
No Valves
- Z198048** 32mm dia. Barrel x 250mm lgth.
With Valves Wt. 1.7kg
- Z198047** 32mm dia. Barrel x 460mm lgth.
With Valves Wt. 2.0kg
- Z198046** 35mm dia. Barrel x 250mm lgth.
With Valves Wt. 1.7kg
- Z198051** 35mm dia. Barrel x 460mm lgth.
With Valves Wt. 2.0kg
- 6259B** Tip Nut

- NOTE:**
- 1) All Torches are three tube design; needed for high speed Tips.
 - 2) Torch length can be altered. Charge applies.
 - 3) Check **Harris** stock holdings before ordering.

Machine Cutting Torches

Acetylene

- | | |
|----------------|----------------------------------------------------------------------------|
| 1332 | 30mm dia. Barrel x 65mm lgth.*
No Valves |
| Z198058 | 30mm dia. Barrel x 250mm lgth.*
With Valves Wt. 1.7kg |
| Z198060 | 30mm dia. Barrel x 460mm lgth.*
With Valves Wt. 2.0kg |
| Z198052 | 32mm dia. Barrel x 110mm lgth.
No Valves |
| 198030 | 32mm x 32mm Square Barrel
x 242mm lgth. With Valves Wt. 1.3kg |
| Z198056 | 32mm dia. Barrel x 250mm lgth.*
With Valves Wt. 1.7kg |
| Z198057 | 32mm dia. Barrel x 460mm lgth.*
With Valves Wt. 2.0kg |
| Z198059 | 35mm dia. Barrel x 250mm lgth.*
With Valves Wt. 1.7kg |
| Z198061 | 35mm dia. Barrel x 460mm lgth.* Wt. 2.0kg |
- NOTE:** *The above are equal pressure Acetylene Torches.

Specialty Torches and Tips

This Torch has a built-in Pilot Flame which can be adjusted to small for economy, or increased to a full flame. Can also be set up as a deadman shut-off lever for added safety. Tip can be swivelled in any direction. Ideal for soft soldering, preheating castings, mould drying, burning paint, heating for the hard surfacing process, annealing copper tubing, and many other heating applications.

Compressed Air/Propane Torch

- | | |
|---------------|---------------------------------------------------------------------|
| HC1892 | Heating Torch complete with
Stainless Steel Tip Wt. 1.2kg |
| 8112 | Heating Tip for HC1892 |

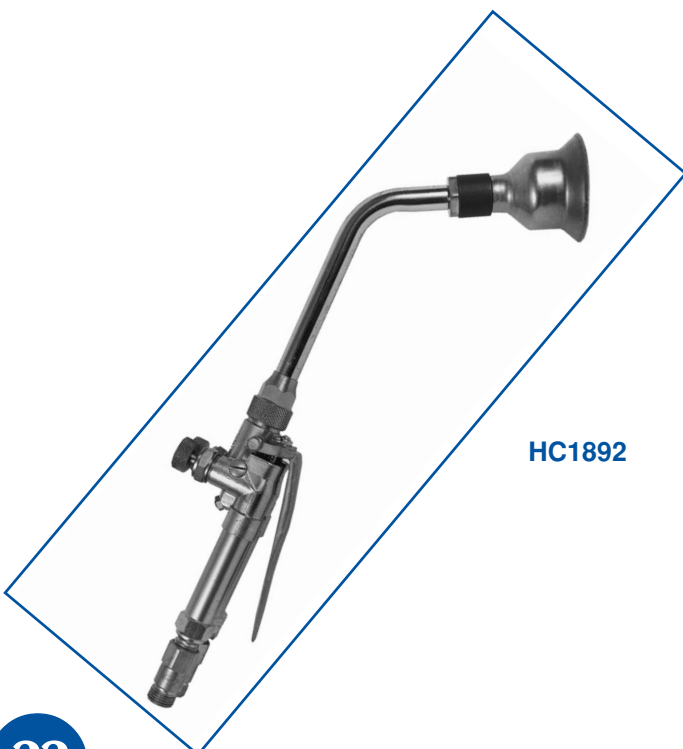

HC1892

Specialty Torches and Tips

Model 80 Jumbo Torch

1100010 Designed for heavy cutting; up to 1000mm in thickness. Contact **Harris** for advice

Powder Spray Torch

A hot Puddle Torch for the Powder Spraying process. Ideal for most maintenance workshops. Kit comprises Handle, Mixer Powder Attachment, Tip Tube, Three Tips and Plastic Powder Tank.



Z187003

Z187003 Powder Spray Torch Kit **Wt.1.0kg**

18781LT Plastic Tank

1879045H Powder Spray Tip No. 45

1879048H Powder Spray Tip No. 48

1879053H Powder Spray Tip No. 53

B187 Powder Spray Tip Tube

RBP432 Flame cleaning, Strip heating
Oxy Propane, LPG, Nat Gas Tips

RBP434 50mm wide
Flame cleaning, Strip heating
Oxy Propane, LPG, Nat Gas Tips

RBP436 100mm wide
Flame cleaning, Strip heating
Oxy Propane, LPG, Nat Gas Tips
150mm wide