

362

Cutting Attachments

LIGHT/MEDIUM DUTY

A well designed robust attachment with outstanding cutting capacity of 75mm. Sets the standard for smaller torch use.

Features include- Wt. 0.4kg

- ▶ Head/body in solid forged brass
- ▶ Triangular stainless steel gas tubes for maximum strength and safety
- ▶ Equal pressure mixing
- ▶ Solid brass lever with stainless steel plunger
- ▶ Unique tapered 'O' ring sealing for safety
- ▶ Suits all gases

362 Contractors Cutt Att. Acetylene/Propane, to suit **Harris** Handle 019038

Note: Tip nut is **9008437**

HEAVY DUTY

A truly professional cutting attachment best suited for the toughest workshop conditions. It has many features that are unmatched by other manufacturers.

Features include- Wt. 0.8kg

- ▶ Triangular stainless steel gas tubes for maximum strength, safety and operator comfort
- ▶ Tapered 'O' ring sealing for longlife/safety (492, 492F, only)
- ▶ Accessible injector allows simple change- over to other gases
- ▶ Cuts to 150mm
- ▶ Accepts flat seating tips, greatly reducing head popping
- ▶ Built in safety plug in head
- ▶ Universal mixing for maximum economy, fuel gas 1.5kPa
- ▶ Head, lever, body solid brass for long life
- ▶ Ease-on built in for better starts and piercing

492F Professional Cutt Att. Propane, LPG, Natural Gas to suit **Harris** original Handle 632, 043013

Note: Tip nut to suit both is **6259B**

492 Professional Cutt Att. Acetylene suit **Harris** original Handle 632, 043013

732 Part of the classic series, a medium pressure acetylene cutting attachment. The tough solid construction surpasses others in the market and cuts to 100mm.

Features include-

- ▶ Solid brass head, body and lever
- ▶ Ease on for easier starts and piercing
- ▶ Stainless steel tubes
- ▶ Suit 632 handle

NO PHOTO

Cutting Attachments

Follows the design of the professional (492) cutting attachment specs, and is made to be **compatible** with other brands. The compatible range is easily identified as the tightening sleeve is machined differently to the 492.

Features include- Wt. 0.8kg

- ▶ Triangular stainless steel gas tubes for maximum strength and safety
- ▶ Slide 'O' ring sealing makes it compatible
- ▶ Accessible injector allows simple change - over to other gases.
- ▶ Accepts flat seating tips, greatly reducing head popping.
- ▶ Built in safety plug in head
- ▶ Universal mixing for maximum economy, fuel gas 1.5kPa
- ▶ Head, lever, body solid brass construction for long life
- ▶ Cuts to 150mm.

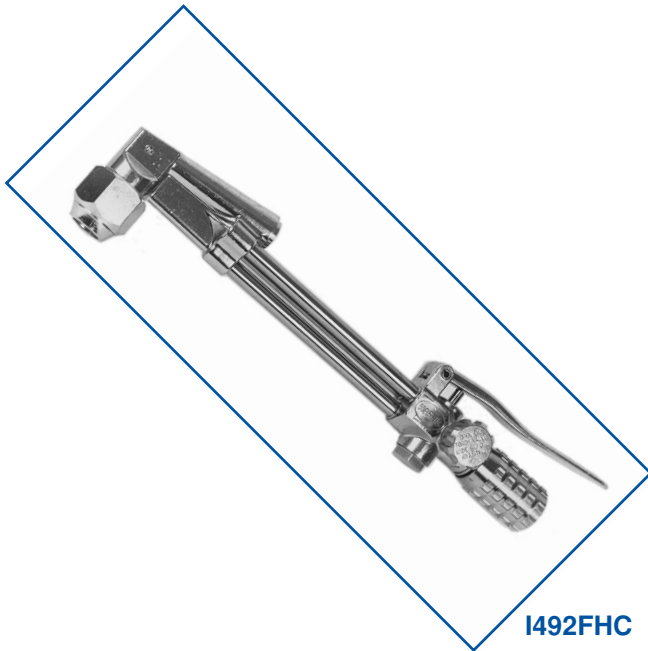

I492FHC

I492FHC * Professional Cutt Att. Propane, LPG, Natural Gas to suit **Harris** "Compatible" Handle and other manufacturers.

I492HC * Professional Cutt Att. Acetylene, to suit **Harris** Handle (I432HC). Fits most makes of Handles. "Compatible"

6259B Tip nut

The **073004** is an expansion of the above Professional range and is considered the toughest in the market because -

Features include- Wt. 0.8kg

- ▶ Triangular stainless steel gas tubes
- ▶ Solid brass head
- ▶ **Accepts standard taper seating tips**
- ▶ Solid brass body
- ▶ Solid brass lever
- ▶ One mixer for all fuel gases
- ▶ Compatible with other manufacturers

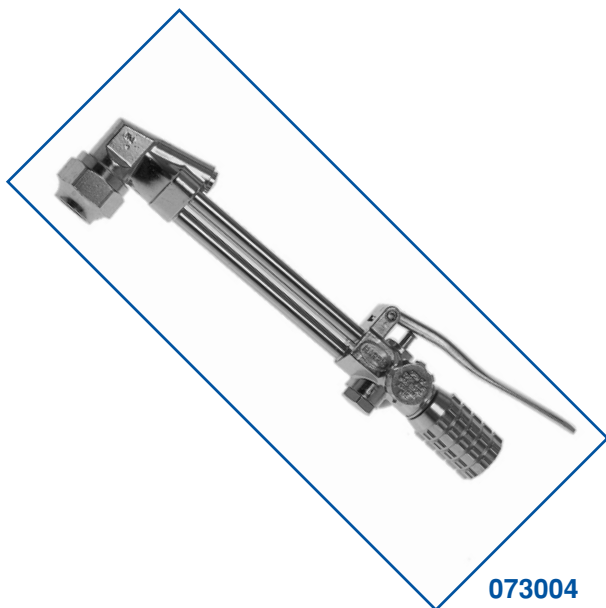

073004

9005218 Tip nut to suit



019038



050008



043013

Handles

LIGHT/MEDIUM DUTY

This lightweight all metal handle is ideal for handyman, plumber, panel beater and the like.

Features include- **Wt. 0.8kg**

- ▶ Front mounted valves for fast flame adjustment with ability to change flame one handed, by using thumb
- ▶ Two separate stainless steel gas tubes
- ▶ Front/rear pieces of forged brass
- ▶ Good flow for lightweight handle
- ▶ Complete with flashguards

Automatic Handle LPG, Propane, Natural Gas.
Built-in pilot flame adjustment (Fuel Gas & Oxygen).

Uses - Manufacturers, Radiator Shops, Jewellers.
Includes Flashguards

A lightweight Torch with unique features

Features include- **Wt. 0.4kg**

- ▶ Switch from operating flame to pilot flame by releasing the thumb lever
- ▶ Gas economiser built in to Torch
- ▶ Lever can be adjusted to shut off gas, extra safety, called deadman

HEAVY DUTY

Professional handle with **Harris original** stainless steel head which supplies high flow for the largest heating application. Its toughness will add another dimension to workshop use.

Features include- **Wt. 0.7kg**

- ▶ Tough extruded brass handle
- ▶ Tube within a tube for high flow
- ▶ Stainless steel connector for long life
- ▶ No screws or soldered joints for easy maintenance
- ▶ Unique tapered 'O' ring sealing for extra safety
- ▶ Large flow valves
- ▶ Stainless steel ball valves
- ▶ Flashguards included

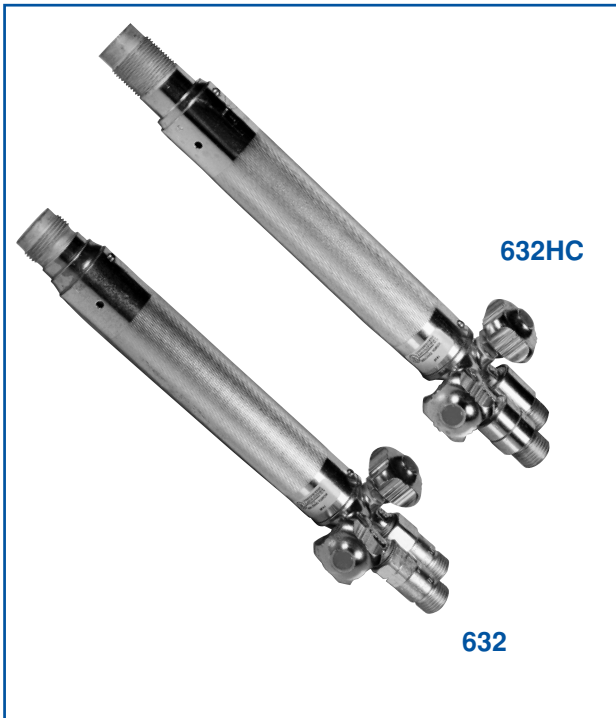

Handles

This Classic series 632 Handle is designed for normal workshop use. It will operate heating tips up to a size 3, which suits most applications. The handle comes in two Models - **Compatible**

- **Harris Original**

You decide which is best for you.

Features include- Wt. 1.0kg

- ▶ Tough extruded brass handle
- ▶ Brass connector
- ▶ Slide 'O' ring fitment (compatible 632HC)
- ▶ Tapered 'O' ring seal (original 632)
- ▶ S.S. ball valves
- ▶ Flashguards incl.
- ▶ Comfortable
- ▶ Made for right hand or left hand use
- ▶ Fuel gas valve easily accessible in the event of a flashback



Acetylene Mixers

Mixing the gas is very important to the flame. **Harris** is proud of its range and the many uses, via tips and adaptors, that are available. **Note:** That the mixers and tip thread, only accepts **Harris** tips, which are designed to give the best in gas sealing and safety.

- H192E** Precision Equal Pressure Acetylene Mixer for 5090, 1390, 0090 Tips & J63 2 Heating Tip
- E43** Professional Equal Pressure Acetylene Mixer for 23A90 0-10, 1390 0-10, 0090 1,3,5,6,8 Tips and J63 2 Heating Tip
- E43HC** Professional Equal Pressure Acetylene Mixer for 23A90 0-10, 1390 0-10, 0090 1,3,5,6,8 Tips and J63 2 Heating Tip. Compatible range fits most brands of Handles.
- E243** Professional Equal Pressure Acetylene Mixer for 23A90 13, 15 & J633/J634 Heating Tips
- E343** Professional Equal Pressure Acetylene Mixer for J143-5 Heating Tip



Propane Mixers

Accurate mixing is vital to a good flame with these fuel gases. If possible, use the mixer for the tip range to achieve the best flame characteristics. The **Harris** range is truly world class and will open up applications for the end user, making for an easier, safer workplace.

Propane, LPG, Natural Gas

- H192S** Precision Universal Pressure Mixer for 1390N, 1390 H, 0090 Tips*
- B191** Precision Universal Pressure Mixer for 1390 00N-2N, 0090 2N Tips. Gives precise mixing, better flame for these Tip sizes*
- B193** Precision Universal Pressure Mixer for 1390 4N-10N, 1390 H, 4N,6N,8N. Gives precise mixing better flame for these Tip sizes*
- B433** Professional Universal Pressure Mixer for 1390 00-3N, 0090 2N Gives Precise mixing, better flame*
- B436** Professional Universal Pressure Mixer for 1390 4N-7N, 0090 4N, 6N. Gives precise mixing, better flame*
- B438** Professional Universal Pressure Mixer for 1390 8N-10N
- NOTE:** Use B436 as a general purpose mixer, all sizes. Flame mixing not as precise as the correct size matched with tip. * See above - Will still operate on other sizes.
- B43N** Professional Universal Pressure Mixer for Oxy/Natural Gas, using large volume 2290 1H-3H Oxy/Propane Tips, fits 043013, 632
- F43** Professional Mixer for heating, using large volume 2290 1H-5H Propane Tips, fits 043013, 632

Oxy/Acetylene

These two piece tips are very popular. Their flame characteristics, plus the ease of cleaning, make them ideal for Plumbers, Panel Beaters and other Contractors.



To suit 362 Cutting Att.

	Size	Precision Series
3690	00AC	Cuts 0- 6mm Steel
3690	OAC	Cuts 6- 13mm Steel
3690	1AC	Cuts 13- 25mm Steel
3690	2AC	Cuts 25- 75mm Steel

Oxy/Acetylene

This Professional tip offers exceptionally quick starting for the operator, combined with the ability to pull apart to clean. The flat seating allows easy reseating on-site with a rub with wet/dry - **a very unique product.** This flat seating tip greatly reduces the occurrence of tip popping. Precise gas flutes control the amount of gas being used.



To suit 492 Cutt.Att., 142 & 624L Torches

	Size	Professional Series
6290	000	Cuts 0-5mm Steel (One pce copper)
6290	00AC	Cuts 5- 10mm Steel
6290	0AC	Cuts 10- 15mm Steel
6290	1AC	Cuts 15- 25mm Steel
6290	2AC	Cuts 25- 50mm Steel
6290	3AC	Cuts 50-100mm Steel
6290	4AC	Cuts 100-175mm Steel
6290	5AC	Cuts 175-250mm Steel
6290	6AC	Cuts 250-300mm Steel

NOTE: Standard 5mm Hose does limit good cutting to 100mm. For thicker steel, use larger diameter Hose.